

Specifications for **Hoists** and **Trolleys**



Table of Contents

Electric Hoists—Chain

Lodestar	1-7
Lodestar XL	8-12
ShopStar	13-14
Valustar	15-16
Powerstar	17-23

Electric Hoists—Wire Rope

Polaris	24-28
Apollo	29-33

Air Hoists

Lodestar Air XL	34-37
ShopAir	38-39
Airstar	40-42
Airstar 6	43-45
Max Balancer	46-48
TMM -140 Manipulator	49-50

Hand Chain Hoists

Hurricane 360°	51-52
Cyclone	53-56
Cyclone Army Type	57-58
Cyclone Low Headroom	59-62
Series 622	63-64

Lever Tools—Chain

Series 602 Mini Ratchet	65-66
Series 653	67-68
Puller	69
Short Handle Puller	70
Rigger	71

Lever Tools—Wire Rope

Wire Rope Lever Hoist	72
GT Series Grip and Pull	73

Trolleys

Series 632 Close Radius	74
Series 84A Heavy Duty	75-76
Series 80	77-78
Series 633 Wide Range	79
Railstar	80
Tractor Drive	81

Hoist Test Stand	82-83
------------------	-------



Lodestar electric chain hoist

The balanced, integrated, proven design of the Lodestar has made it the most popular electric chain hoist in the industry. Lodestar gives you more value for your money including:

- Quick change voltage board-change from low voltage to high voltage by simply repositioning receptacle
- Up to 3 ton capacities for heavy-duty industrial applications
- Gear train lifetime lubricated with non-oxidizing grease
- Precision machined and hardened liftwheel with hardened chain guides for precise chain liftwheel fit
- Gearing designed for exceptionally long life and quiet operation
- H4 duty standard
- Rugged control station (NEMA 4X)
- Hoist duty motor, standard Protector overload device and standard screw type limit switches
- Hardened, forged steel, latch type hooks and Hoistaloy load chain for long, dependable service
- Easy to install and maintain
- No special tools required to disassemble
- Lifetime warranty
- Each hoist thoroughly inspected and tested to over 125% of rated load prior to shipment
- Meets ASME B30.16
- Metric rated
- Made in U.S.A.



Special applications

- Harsh environment hoists available for severe duty of plating, galvanizing and washdown applications
- Hoists with climbing capability available for temporary rigging or lifting applications — must be used in inverted position only
- Hoists with creep control allow precise positioning through field adjustment within the time delay range of .05 sec. to 3 sec.
- Articulating suspension 3 ton only

Specifications — two speed

Rated capacity* (tons)	Standard lift (ft.)	Lift speed (F.P.M.)	Motor H.P.	Model	Reeving	Product code† less suspension		Approximate shipping weight (lbs.)
						230-3-60	460-3-60	
1/8	10	10/32	1/4	A2	1	2707	2708	70
	10	20/60	1/2	AA2	1	2717	2718	74
1/4	10	5/16	1/4	B2	1	2727	2728	70
	10	10/32	1/2	C2	1	2737	2738	74
1/2	10	2.5/8	1/4	E2	2	2747	2748	79
	10	5/16	1/2	F2	1	2757	2758	74
	10	10/32	1	J2	1	3502	3503	116
	10	21/64	2	JJ2	1	3549	3550	130
1	10	2.5/8	1/2	H2	2	2767	2768	83
	10	5/16	1	L2	1	3504	3505	116
	10	10/32	2	LL2	1	3553	3554	130
2	10	2.5/8	1	R2	2	3506	3507	136
	10	5/16	2	RR2	2	3561	3562	150
3	10	1.75/5.5	1	RT2	3	9511	9513	161
	10	3.5/11	2	RRT2	3	9512	9514	175

†Specify voltage 230 or 460



Lodestar* electric chain hoist - Specifications

Specifications — single speed

Rated capacity* (tons)	Standard lift (ft.)	Lift speed (F.P.M.)	Motor H.P.	Model	Reeving	Product code† less suspension		Approximate shipping weight (lbs.)
						115-1-60	230/460-3-60	
1/8	10	32	1/4	A	1	2702	2705	60
	10	60	1/2	AA	1	2712	2715	66
	15	32	1/4	A	1	3101	3103	64
	15	60	1/2	AA	1	3111	3113	70
	20	32	1/4	A	1	3102	3104	68
	20	60	1/2	AA	1	3112	3114	74
1/4	10	16	1/4	B	1	2722	2725	60
	10	32	1/2	C	1	2732	2735	66
	15	16	1/4	B	1	3121	3123	64
	15	32	1/2	C	1	3131	3133	70
	20	16	1/4	B	1	3122	3124	68
	20	32	1/2	C	1	3132	3134	74
1/2	10	8	1/4	E	2	2742	2745	69
	10	16	1/2	F	1	2752	2755	66
	10	32	1	J	1	3512	3515	110
	10	64	2	JJ	1	—	3545	117
	15	8	1/4	E	2	3141	3143	76
	15	16	1/2	F	1	3151	3153	70
	15	32	1	J	1	4212	4214	116
	15	64	2	JJ	1	—	4244	123
	20	8	1/4	E	2	3142	3144	83
	20	16	1/2	F	1	3152	3154	74
	20	32	1	J	1	4213	4215	121
	20	64	2	JJ	1	—	4245	128
1	10	8	1/2	H	2	2762	2765	75
	10	16	1	L	1	3522	3525	110
	10	32	2	LL	1	—	3555	117
	15	8	1/2	H	2	3161	3163	82
	15	16	1	L	1	4222	4224	116
	15	32	2	LL	1	—	4254	123
	20	8	1/2	H	2	3162	3164	89
	20	16	1	L	1	4223	4225	121
	20	32	2	LL	1	—	4255	128
2	10	8	1	R	2	3532	3535	130
	10	16	2	RR	2	—	3565	137
	15	8	1	R	2	4232	4234	140
	15	16	2	RR	2	—	4264	147
	20	8	1	R	2	4233	4235	150
	20	16	2	RR	2	—	4265	157
3	10	5.5	1	RT	3	9501	9505	155
	10	11	2	RRT	3	—	9508	162
	15	5.5	1	RT	3	9502	9506	169
	15	11	2	RRT	3	—	9509	176
	20	5.5	1	RT	3	9503	9507	183
	20	11	2	RRT	3	—	9510	190

†Single speed hoist factory wired 460V, convertible to 230V.

Lodestar with hook suspension

Clearance dimensions (in.)

Dimension	Lodestar models					
	A,B,C,F and AA	E and H	J, L, JJ and LL	R	RR	RT and RRT
A	16 ¹ / ₄	19 ⁵ / ₈	18 ⁹ / ₁₆	24 ¹ / ₈	24 ¹ / ₈	29 ⁹ / ₁₆
B	6 ¹ / ₈	6 ¹ / ₈	7 ⁵ / ₈	7 ⁵ / ₈	7 ⁵ / ₈	7 ⁵ / ₈
C	1 ¹ / ₁₆	7 ⁷ / ₈	7 ⁷ / ₈	1 ¹ / ₈	1 ¹ / ₈	1 ¹ / ₈
D	11	11	9 ¹ / ₂	9 ¹ / ₂	9 ¹ / ₂	9 ¹ / ₂
F	7 ³ / ₄	7 ³ / ₄	10 ¹¹ / ₁₆	10 ¹¹ / ₁₆	10 ¹¹ / ₁₆	10 ¹¹ / ₁₆
H	1	1 ³ / ₁₆	1 ³ / ₁₆	1 ¹ / ₂	1 ¹ / ₂	1 ¹ / ₂
I	4 ¹³ / ₁₆	3 ⁷ / ₈	7 ¹ / ₄	6 ³ / ₁₆	6 ³ / ₁₆	6 ³ / ₁₆
J	3 ¹⁵ / ₁₆	4 ⁷ / ₈	5 ⁷ / ₁₆	6 ¹ / ₂	6 ¹ / ₂	6 ¹ / ₂
L	1 ¹¹ / ₁₆	1 ¹¹ / ₁₆	7 ¹ / ₁₆	7 ¹ / ₁₆	7 ¹ / ₁₆	7 ¹ / ₁₆
M	1	1 ¹ / ₈	1 ¹ / ₈	1 ⁵ / ₁₆	1 ⁵ / ₁₆	1 ⁵ / ₁₆
P	6 ⁵ / ₈	6 ⁹ / ₁₆	7 ¹³ / ₁₆	7 ¹³ / ₁₆	7 ¹³ / ₁₆	7 ¹³ / ₁₆
R*	9 ⁷ / ₈	12 ⁷ / ₈	12 ⁷ / ₈	18 ⁷ / ₈	18 ⁷ / ₈	24 ⁷ / ₈
AP	9 ¹ / ₄	9 ⁹ / ₁₆	10 ¹¹ / ₁₆	11 ³ / ₁₆	11 ³ / ₁₆	12 ⁹ / ₁₆

* Based on 10 ft. lift and increases proportionately with longer lifts



Suspension specifications

Type	Product code	Models
Swivel hook	2792	A-AA-B-C-F
Swivel hook	2793	E-H
Swivel hook	3661	J-L-JJ-LL
Swivel hook	3660	R-RR
Swivel hook	9557	RT-RRT
Swivel latchlok hook	2796	A-AA-B-C-F
Swivel latchlok hook	3662	J-L-JJ-LL
Swivel latchlok hook	3663	R-RR
Rigid lug for low head trolley	2778	A-AA-B-C-F
Rigid lug for low head trolley	2779	E-H
Rigid lug for low head trolley	3677	J-L-JJ-LL
Rigid lug for low head trolley	3668	R-RR
Rigid lug for low head trolley	9561	RT-RRT
Rigid hook	2788	A-AA-B-C-F
Rigid hook	2789	E-H
Rigid hook	3651	J-L-JJ-LL
Rigid hook	3658	R-RR
Rigid hook	9559	RT-RRT
Rigid latchlok hook	2790	A-AA-B-C-F
Rigid latchlok hook	3652	J-L-JJ-LL

Note: 3 ton lug suspension prevents hoist from rotating but allows hoist to articulate below trolley

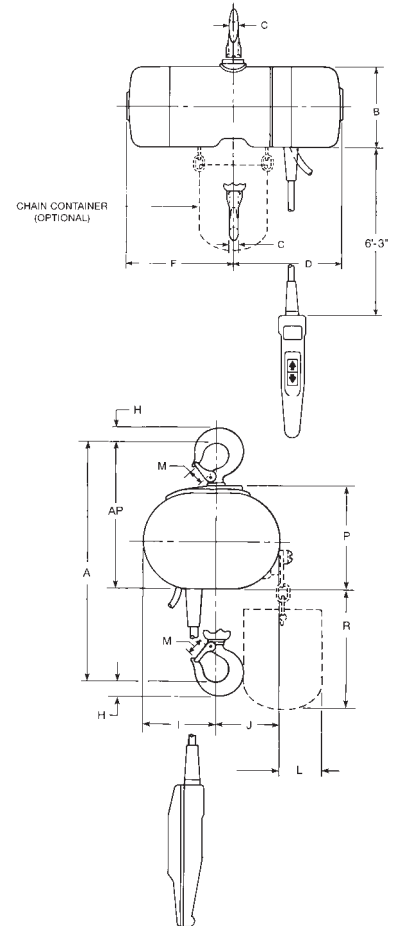

* WARNING

Overloading and improper use can result in injury.

To avoid injury:

- Do not exceed working load limit, load rating capacity
- Do not use to lift people or loads over people.
- use only alloy chain for overhead lifting.
- Read and follow all instructions.

Lodestar with Series 635 low headroom trolley

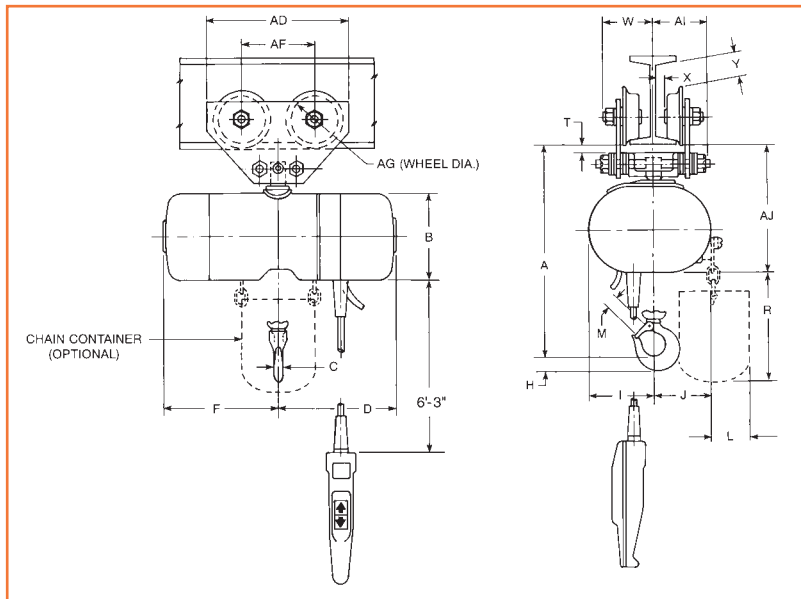

Clearance dimensions (in.)

Dimension	Lodestar models					
	A,B,C,F and AA	E and H	J, L, JJ and LL	R	RR	RT and RRT
A	16 ⁵ / ₁₆	19 ¹ / ₄	18 ¹ / ₄	23 ³ / ₄	23 ³ / ₄	30 ¹ / ₈
B	6 ¹ / ₈	6 ¹ / ₈	7 ⁵ / ₈	7 ⁵ / ₈	7 ⁵ / ₈	7 ⁵ / ₈
C	1 ¹ / ₁₆	7 ⁷ / ₈	7 ⁷ / ₈	1 ¹ / ₈	1 ¹ / ₈	1 ¹ / ₈
D	11	11	9 ¹ / ₂	9 ¹ / ₂	9 ¹ / ₂	9 ¹ / ₂
F	7 ³ / ₄	7 ³ / ₄	10 ¹¹ / ₁₆	10 ¹¹ / ₁₆	10 ¹¹ / ₁₆	10 ¹¹ / ₁₆
H	1	1 ³ / ₁₆	1 ³ / ₁₆	1 ¹ / ₂	1 ¹ / ₂	1 ¹ / ₂
I	4 ¹³ / ₁₆	3 ⁷ / ₈	7 ¹ / ₄	6 ³ / ₁₆	6 ³ / ₁₆	6 ³ / ₁₆
J	3 ¹⁵ / ₁₆	4 ⁷ / ₈	5 ⁷ / ₁₆	6 ¹ / ₂	6 ¹ / ₂	6 ¹ / ₂
L	1 ¹¹ / ₁₆	1 ¹¹ / ₁₆	7 ¹ / ₁₆	7 ¹ / ₁₆	7 ¹ / ₁₆	7 ¹ / ₁₆
M	1	1 ¹ / ₈	1 ¹ / ₈	1 ⁵ / ₁₆	1 ⁵ / ₁₆	1 ⁵ / ₁₆
R†	9 ⁷ / ₈	12 ⁷ / ₈	12 ⁷ / ₈	18 ⁷ / ₈	18 ⁷ / ₈	24 ⁷ / ₈
T	1 ³ / ₁₆	1 ³ / ₁₆	1 ³ / ₁₆	7 ⁷ / ₈	7 ⁷ / ₈	5 ¹ / ₁₆
W	3	3	3	3 ⁵ / ₈	3 ⁵ / ₈	4 ¹ / ₈
X	5 ¹ / ₁₆	5 ¹ / ₁₆	5 ¹ / ₁₆	1 ¹ / ₂	1 ¹ / ₂	9 ¹ / ₁₆
Y	1 ¹ / ₁₆	1 ¹ / ₁₆	1 ¹ / ₁₆	3 ¹ / ₁₆	3 ¹ / ₁₆	2 ⁵ / ₈
AD	9 ³ / ₄	9 ³ / ₄	9 ³ / ₄	13	13	12 ¹ / ₂
AF	5	5	5	6	6	6
AG	3 ¹ / ₈	3 ¹ / ₈	3 ¹ / ₈	4 ³ / ₄	4 ³ / ₄	4
AI	4 ⁵ / ₈	4 ⁵ / ₈	4 ⁵ / ₈	5	5	5 ¹ / ₂
AJ	9 ³ / ₁₆	9 ³ / ₁₆	10 ³ / ₈	10 ¹³ / ₁₆	10 ¹³ / ₁₆	13 ¹ / ₈

† Based on 10 ft. lift and increases proportionately with longer lifts

Dimensions T, W, X, Y, AI, and AJ are based on minimum beams and will vary proportionately for larger beams. 6'-3" drop of control station is for 10 foot lift hoist and increases proportionately for longer lifts.

Specifications For Series 635 Trolley

Rated capacity* (tons)	Product code	Models	Std. range of adjust. Am. standard S-beams		Tread diameter (in.)	Minimum radius curve (in.)	Approximate shipping weight (lbs.)
			Depth (in.)	Flange width (in.)			
1/8 to 1	3575	A – LL	4 – 15	2 ⁵ / ₈ – 5 ⁵ / ₈	3 ¹ / ₈	24	22
2	3569	R – RR	6 – 18	3 ³ / ₈ – 6	4 ³ / ₄	24	52
3	9576	RT – RRT	8 – 15	4 – 5 ⁵ / ₈	4 ³ / ₄	30	58

Note: Rigid lug suspension required for attaching to hoist. Apply for other than standard beam adjustment. Beam end stop omitted for picture clarity

Lodestar with Series 635 motor driven trolley

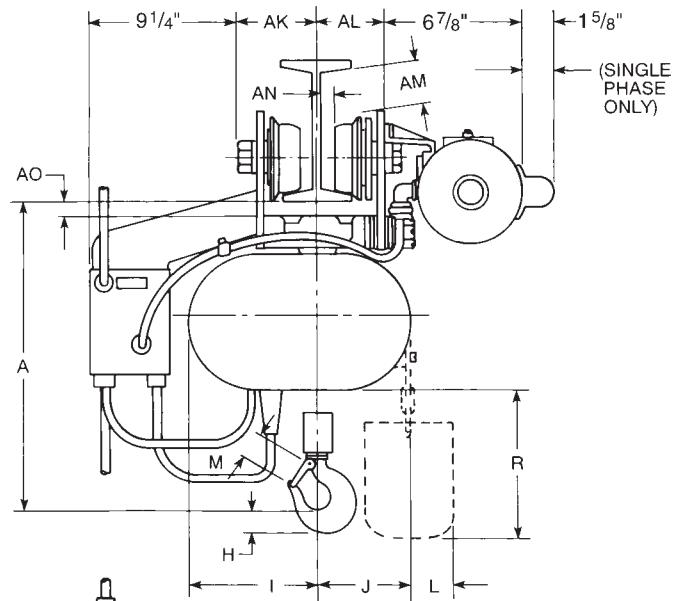
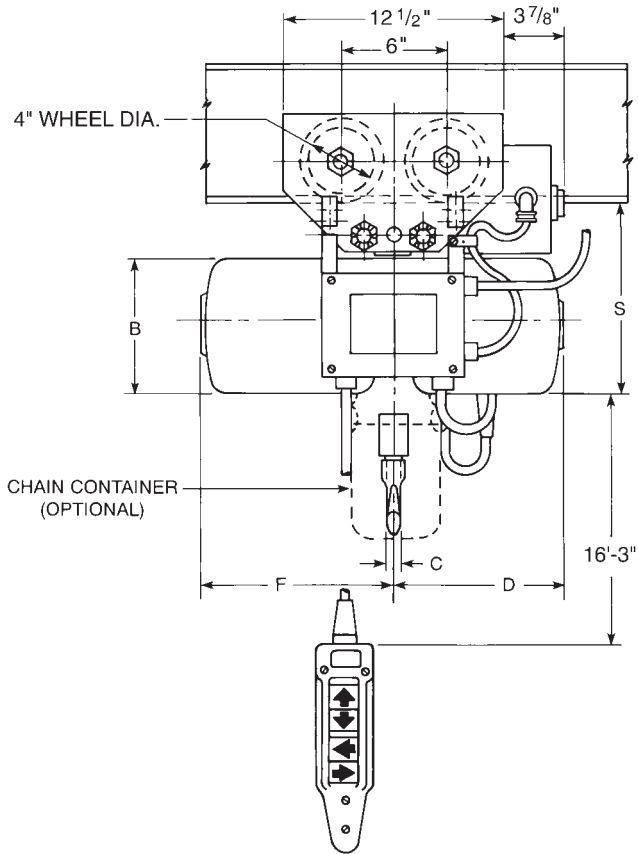

*** ⚠ WARNING**

Overloading and improper use can result in injury.

To avoid injury:

- Do not exceed working load limit, load rating capacity
- Do not use to lift people or loads over people.
- use only alloy chain for overhead lifting.
- Read and follow all instructions.



Lodestar with Series 635 motor driven trolley-Specifications

Clearance dimensions (in.)

Dimension	Lodestar models †					
	A,B,C,F and AA	E and H	J, L, JJ and LL	R	RR	RT and RRT
A	16 ^{13/16}	19 ^{3/4}	18 ^{1/2}	23 ^{3/4}	23 ^{3/4}	30 ^{1/8}
B	6 ^{1/8}	6 ^{1/8}	7 ^{5/8}	7 ^{5/8}	7 ^{5/8}	7 ^{5/8}
C	1 ^{1/16}	7/8	7/8	1 ^{1/8}	1 ^{1/8}	1 ^{1/8}
D	11	11	9 ^{1/2}	9 ^{1/2}	9 ^{1/2}	9 ^{1/2}
F	7 ^{3/4}	7 ^{3/4}	10 ^{11/16}	10 ^{11/16}	10 ^{11/16}	10 ^{11/16}
H	1	1 ^{3/16}	1 ^{3/16}	1 ^{1/2}	1 ^{1/2}	1 ^{1/2}
I	4 ^{13/16}	3 ^{7/8}	7 ^{1/4}	6 ^{3/16}	6 ^{3/16}	6 ^{3/16}
J	3 ^{15/16}	4 ^{7/8}	5 ^{7/16}	6 ^{1/2}	6 ^{1/2}	6 ^{1/2}
L	1 ^{11/16}	1 ^{11/16}	7/16	7/16	7/16	7/16
M	1	1 ^{1/8}	1 ^{1/8}	1 ^{5/16}	1 ^{5/16}	1 ^{5/16}
R**	9 ^{7/8}	12 ^{7/8}	12 ^{7/8}	18 ^{7/8}	18 ^{7/8}	24 ^{7/8}
S	9 ^{11/16}	9 ^{11/16}	10 ^{5/8}	10 ^{13/16}	10 ^{13/16}	13 ^{1/8}
AK	3 ^{3/4}	3 ^{3/4}	3 ^{3/4}	3 ^{3/4}	3 ^{3/4}	4 ^{1/4}
AL	3 ^{1/4}	3 ^{1/4}	3 ^{1/4}	3 ^{1/4}	3 ^{1/4}	3 ^{3/4}
AM	5/8	5/8	5/8	5/8	5/8	2 ^{5/8}
AN	5/16	5/16	5/16	5/16	5/16	9/16
AO	7/8	7/8	7/8	7/8	7/8	1

** Based on 10 ft. lift and increases proportionately with longer lifts

Dimensions S, AK, AL, AM, and AO are based on minimum beams and will vary proportionately for larger beams. 16'-3" drop of control station is for 20 foot lift hoist.

† Note: Rigid lug suspension required for attaching to hoist.

Suspension specifications

Type	Product code	Models
Rigid lug for motor driven trolley	2992	A-AA-B-C-F
Rigid lug for motor driven trolley	2993	E-H
Rigid lug for motor driven trolley	3679	J-L-JJ-LL
Rigid lug for motor driven trolley	3668	R-RR
Rigid lug for motor driven trolley	9561	RT-RRT

Note: Beam end stop omitted for picture clarity

Specifications — motor driven trolley

Rated capacity* (tons)	Product code	For use with model	Power supply	Standard travel speed (F.P.M.)	Motor H.P.	Std. range of adj. Am. std. S-beams		Minimum radius curve (in.)	Approx. shipping weight (lbs.)
						Depth (in.)	Flange width (in.)		
1/8 - 2	3670	A-RR	115-1-60	75	1/4	6 - 15	3 ^{3/8} - 5 ^{5/8}	30	118
1/8 - 2	3671	A-RR	230-3-60	75	1/4	6 - 15	3 ^{3/8} - 5 ^{5/8}	30	118
1/8 - 2	3672	A-RR	460-3-60	75	1/4	6 - 15	3 ^{3/8} - 5 ^{5/8}	30	118
3	9577	RT-RRT	115-1-60	75	1/4	8 - 15	4 - 5 ^{5/8}	30	120
3	9578	RT-RRT	230-3-60	75	1/4	8 - 15	4 - 5 ^{5/8}	30	120
3	9579	RT-RRT	460-3-60	75	1/4	8 - 15	4 - 5 ^{5/8}	30	120
1/8 - 2	9315	A-RR	115-1-60	30	1/4	6 - 15	3 ^{3/8} - 5 ^{5/8}	30	113
1/8 - 2	9316	A-RR	230-3-60	30	1/4	6 - 15	3 ^{3/8} - 5 ^{5/8}	30	113
1/8 - 2	9317	A-RR	460-3-60	30	1/4	6 - 15	3 ^{3/8} - 5 ^{5/8}	30	113
3	9318	RT-RRT	115-1-60	30	1/4	8 - 15	4 - 5 ^{5/8}	30	120
3	9319	RT-RRT	230-3-60	30	1/4	8 - 15	4 - 5 ^{5/8}	30	120
3	9320	RT-RRT	460-3-60	30	1/4	8 - 15	4 - 5 ^{5/8}	30	120

Can be modified to fit larger beams.
Flat tread wheel available.
Beam size and voltage required for ordering.

Apply for other than standard travel speeds.



DISTRIBUIDOR AUTORIZADO MEX (55) 53 63 23 31 MTY (81) 83 54 10 18 QRO (442) 1 95 72 60 ventas@industrialmagza.com



Metal chain container

Specifications

Product code	Lodestar hoist model	Valustar hoist model	Maximum length of lift (ft.)	Length of chain bucket (in.)
2450	A-AA-B-C-F	WB-WF	10	8
2451	E-H	WH-WE	10	11
2451	A-AA-B-C-F	WB-WF	20	11
2451	J-JJ-L-LL	WJ-WL	10	11
2453	R-RR	WR	10	17
2453	J-JJ-L-LL	WJ-WL	20	17
2452	E-H-J-JJ-L-LL	WE-WH-WL-WJ	15	14
2453	E-H	WE-WH	20	17
2455	R-RR	WR	15	23
2456	R-RR	WR	20	31
2455	RT-RRT	-	10	23
2457	RT-RRT	-	15	36
2457	RT-RRT	-	20	36
2458	A-AA-B-C-F	WB-WF	140	48
2458	E-H	WH	70	48
2458	J-JJ-L-LL	WL	90	48
2458	R-RR	WR	45	48
2458	RT-RRT	-	30	48

- Convenient for slack chain storage
- Simple one pin attachment for easy installation
- Security cable included
- Available for every Lodestar and Valustar model
- Made in U.S.A.

Fabric chain bag

CM's chain bags offer an alternative to the standard metal chain container for use with Lodestar or Valustar electric chain hoists. Chain bags are made from an open weave vinyl coated polyester designed especially for extended outdoor life. Not recommended for applications over 300°F, in extremely caustic environments or for chain weight exceeding 300 lbs. Features include:

- Flexible and lightweight material
- Dampens noise
- Will not hold water
- Excellent resistance to ultraviolet rays, mildew stains, rot and weather
- Moisture resistant - quick drying
- High tensile and tear strength
- Abrasion resistant
- No shrinkage
- Bags and brackets are suitable for chain weights up to 300 pounds
- Made in U.S.A.



Specifications

Product code	Maximum length of lift (ft.)					Bag size (in.)	Bag height (in.)	Approx. weight (lbs.)
	Models A-AA-B-C-F WB-WF	Models E-H WH-WE	Models J,JJ,L,LL WL-WJ	Models R,RR WR	Models RT,RRT			
2470	20	10	-	-	-	7½ x 7½	7	3
2471	40	20	-	-	-	7½ x 7½	10	3
2472	60	30	-	-	-	7½ x 7½	13	3
2473	90	45	-	-	-	7½ x 7½	16	4
2474	100	60	-	-	-	7½ x 7½	18	4
2475	140	90	-	-	-	7½ x 7½	20	4
2476	-	-	10	-	-	7½ x 7½	7	3
2477	-	-	20	10	-	7½ x 7½	10	3
2478	-	-	30	15	10	7½ x 7½	13	3
2479	-	-	45	20	-	7½ x 7½	16	4
2480	-	-	60	30	20	7½ x 7½	18	4
2481	-	-	90	45	30	7½ x 7½	20	4

Lodestar XL electric chain hoist

Columbus McKinnon introduces an expanded line of Lodestar XL electric chain hoists for lifting applications from 2 to 7½ tons. The new offering provides heavy-duty hoists featuring faster speeds, less reeving, and higher capacities than traditional chain hoists. Workers in automotive plants, heavy equipment manufacturing, paper mills, and related rugged work environments will experience the same dependability and versatility that they have relied on for many years.

The NEW features of the Lodestar XL Electric Chain Hoist include:

- Lifting capacities up to 7½ tons
- Increased lifting speeds throughout the line
- Double reeved units with 3-5 ton lifting capacities
- Maximum lifting speed of 30 feet per minute

A glimpse of the many features of the Lodestar XL that have honed its reputation for durability and long life:

- Heavy-duty, multiple disc braking system
- Forged ten-pocket oblique-lay liftwheel for smooth chain operation, constant chain speed, and reduced chain wear
- Gearing operated in oil bath for increased lifting life and quiet operation
- Rated H-4, heavy-duty
- Standard overload protector
- Screw-type limit switches
- Thermally protected motor
- Factory tested at 125% of rated capacity
- Made in U.S.A.



Capacity (tons)	Reeving	Speed (fpm)	230/460-3-60				575-3-60			
			Hook	Plain Trolley	Geared Trolley	Motor Driven Trolley	Hook	Plain Trolley	Geared Trolley	Motor Driven Trolley
2	1	18	5201H	5201P	5201G	5201M	5231H	5231P	5231G	5231M
2	1	24	5204H	5204P	5204G	5204M	5232H	5232P	5232G	5232M
2	1	30	5265H	5265P	5265G	5265M	5266H	5266P	5266G	5266M
3	2	9	5209H	5209P	5209G	5209M	5233H	5233P	5233G	5233M
3	2	12	5212H	5212P	5212G	5212M	5234H	5234P	5234G	5234M
3	2	15	5267H	5267P	5267G	5267M	5268H	5268P	5268G	5268M
4	2	9	5215H	5215P	5215G	5215M	5235H	5235P	5235G	5235M
4	2	12	5218H	5218P	5218G	5218M	5236H	5236P	5236G	5236M
4	2	15	5269H	5269P	5269G	5269M	5278H	5278P	5278G	5278M
5	3	6	5221H	5221P	5221G	5221M	5237H	5237P	5237G	5237M
5	3	8	5224H	5224P	5224G	5224M	5238H	5238P	5238G	5238M
5	2	9	5279H	5279P	5279G	5279M	5280H	5280P	5280G	5280M
5	2	12	5283H	5283P	5283G	5283M	5284H	5284P	5284G	5284M
5	2	15	5285H	5285P	5285G	5285M	5286H	5286P	5286G	5286M
6	3	6	5227H	5227P	5227G	5227M	5239H	5239P	5239G	5239M
6	3	8	5230H	5230P	5230G	5230M	5240H	5240P	5240G	5240M
6	3	10	5287H	5287P	5287G	5287M	5288H	5288P	5288G	5288M
7½	3	6	—	5289P	5289G	5289M	—	5290P	5290G	5290M
7½	3	10	—	5291P	5291G	5291M	—	5292P	5292G	5292M

3.5 H.P. XL Models (unshaded) – Available in single speed, 3:1; two speed, variable speed

5.5 H.P. XL Models (shaded) – Available in single speed, variable speed

Lodestar XL with hook suspension

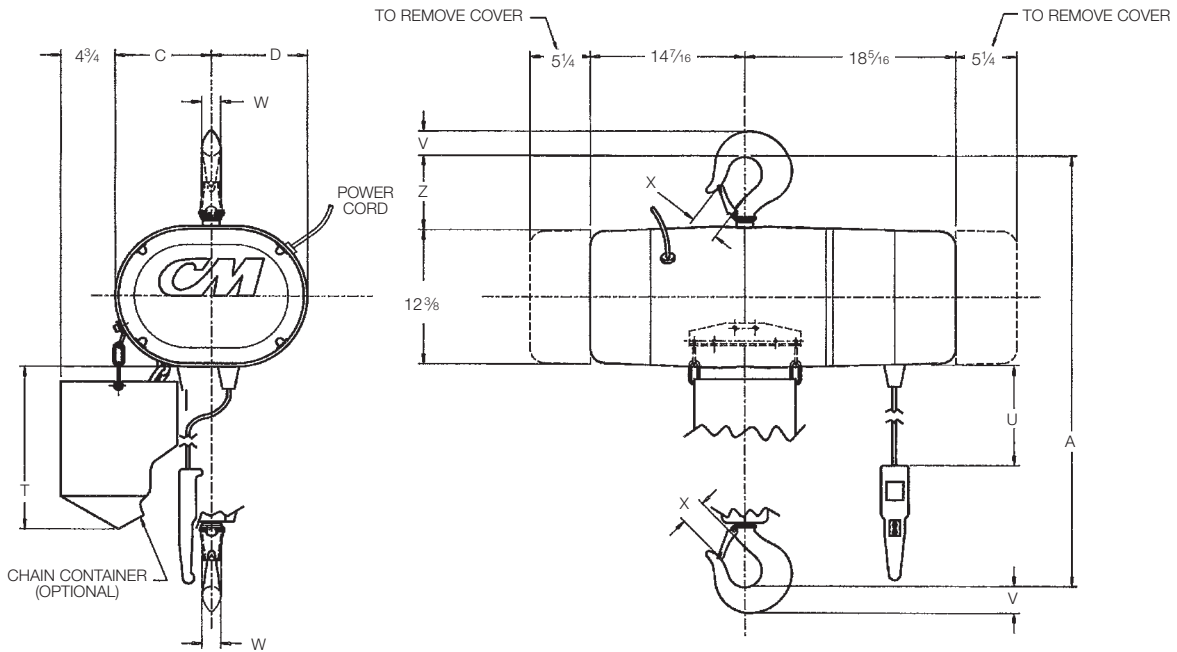

Clearance dimensions (in.)

Dimensions	Single Reeved 2 ton capacity	Double Reeved 3-5 ton capacity	Triple Reeved 5-6 ton capacity
A	25	35 ⁵ / ₁₆	36 ³ / ₁₆
C	8 ⁷ / ₁₆	11 ³ / ₈	11 ³ / ₈
D	8 ¹ / ₈	5 ¹ / ₂	5 ¹ / ₂
T (based on 10 ft. lift)	14 ³ / ₁₆	14 ³ / ₁₆	14 ³ / ₁₆
U (based on 10 ft. lift)	6'- 3"	6'- 3"	6'- 3"
V	1 ¹ / ₂	2 ¹ / ₄	2 ¹ / ₄
W	1 ¹ / ₈	1 ⁵ / ₈	1 ⁵ / ₈
X	1 ⁵ / ₁₆	2 ¹ / ₁₆	2 ¹ / ₁₆
Z	4 ¹ / ₈	5 ¹ / ₂	5 ¹ / ₂



* ⚠ WARNING

Overloading and improper use can result in injury.

To avoid injury:

- Do not exceed working load limit, load rating capacity
- Do not use to lift people or loads over people.
- use only alloy chain for overhead lifting.
- Read and follow all instructions.

Lodestar XL with plain trolley and geared Trolley

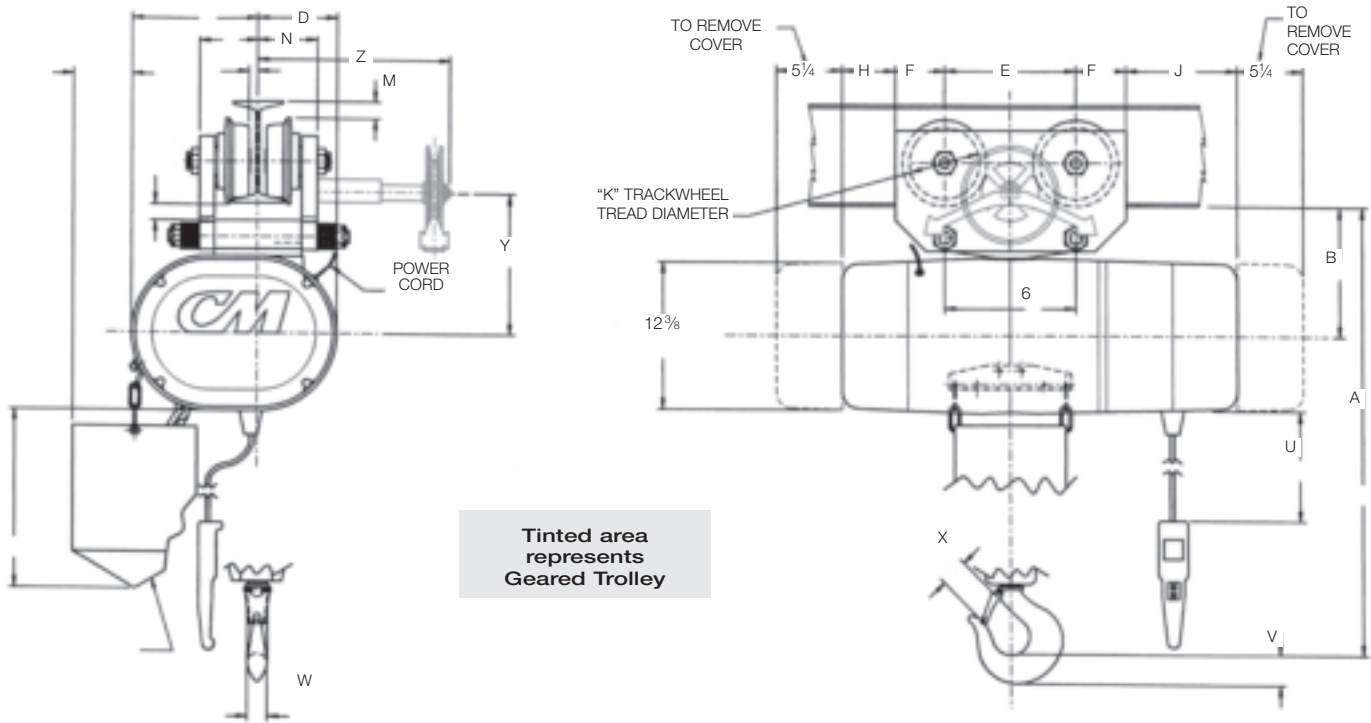

Geared Trolley



Clearance dimensions (in.)**

Dimensions	Single Reeved 2 ton capacity	Double Reeved		Triple Reeved 5-7 1/2 ton capacity
		3 ton capacity	4 & 5 ton capacity	
A	28 ¹ / ₁₆	33 ¹ / ₂	33 ³ / ₄	34 ⁵ / ₈
B	9 ³ / ₄	10 ⁷ / ₁₆	10 ¹ / ₁₆	10 ¹ / ₁₆
C	8 ⁷ / ₁₆	11 ³ / ₈	11 ³ / ₈	11 ³ / ₈
D	8 ³ / ₈	5 ¹ / ₂	5 ¹ / ₂	5 ¹ / ₂
E	9 ¹ / ₂	9 ¹ / ₈	12	12
F	3 ¹ / ₂	3 ¹ / ₄	4 ¹³ / ₁₆	4 ¹³ / ₁₆
H	5 ¹ / ₄	5 ¹¹ / ₁₆	2 ¹ / ₁₆	2 ¹ / ₁₆
J	10 ¹ / ₁₆	10 ¹ / ₂	7 ¹ / ₂	7 ¹ / ₂
K	4 ¹ / ₁₆	4	6 ¹ / ₂	6 ¹ / ₂
L	1/2	5/8	5/8	5/8
M	1/2	2 ¹¹ / ₁₆	0	0
N	5	3 ⁵ / ₈	3 ⁷ / ₈	3 ⁷ / ₈
P	1 ¹ / ₄	3/8	7/16	7/16
T (based on 10 ft. lift)	14 ⁹ / ₁₆	14 ⁹ / ₁₆	14 ⁹ / ₁₆	14 ⁹ / ₁₆
U (based on 10 ft. lift)	6'- 3"	6'- 3"	6'- 3"	6'- 3"
V	1 ¹ / ₂	2 ¹ / ₄	2 ¹ / ₄	2 ¹ / ₄
W	1 ¹ / ₈	1 ⁵ / ₈	1 ⁵ / ₈	1 ⁵ / ₈
X	1 ⁵ / ₁₆	2 ¹ / ₁₆	2 ¹ / ₁₆	2 ¹ / ₁₆
Y*	11 ⁵ / ₁₆	12 ⁷ / ₈	11 ¹ / ₈	11 ¹ / ₈
Z*	—	19 ¹ / ₈	19 ¹ / ₈	19 ¹ / ₈
Minimum Radius Curve (ft.)	4	4	6	6
Standard Beam Flange Adj. Range (in.)	3.33-5.55	4.00-6.25	4.00-6.25	4.00-6.25

*Geared Trolley Dimensions Only

**Dimensions listed are for minimum size "S" beam.

Lodestar XL with motor driven trolley (2 ton)

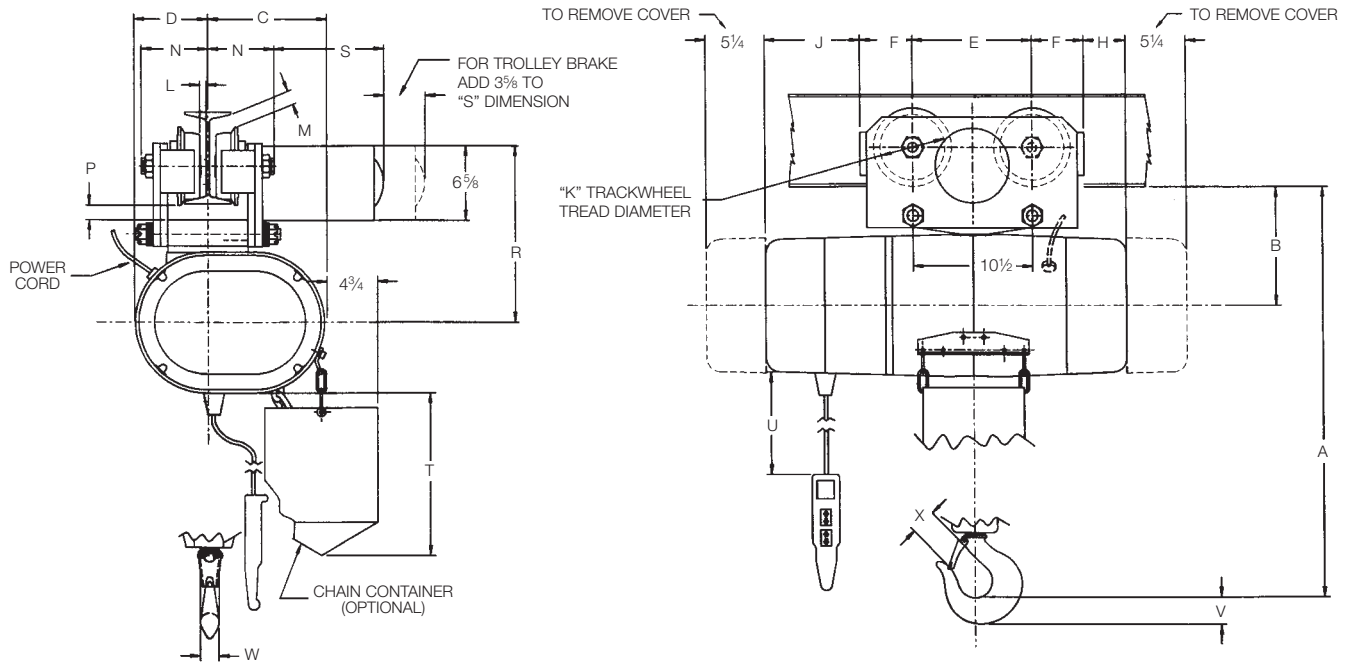

Clearance dimensions (in.)**

Dimensions	Single Reeved 2 ton capacity
A	28 ¹¹ / ₁₆
B	9 ³ / ₄
C	8 ⁷ / ₁₆
D	8 ¹ / ₈
E	9 ¹ / ₂
F	3 ¹ / ₂
H	5 ¹ / ₄
J	10 ¹ / ₁₆
K	4 ¹¹ / ₁₆
L	1/2
M	1/2
N	5
P	1 ¹ / ₄
R	14 ⁵ / ₈
S	12 ⁷ / ₁₆
T (based on 10 ft. lift)	14 ³ / ₁₆
U (based on 10 ft. lift)	6' - 3"
V	1 ¹ / ₂
W	1 ¹ / ₈
X	1 ⁵ / ₁₆
Minimum Radius Curve (ft.)	4
Standard Beam Flange Adj. Range (in.)	3.33-5.55
Trolley Speed (ft./min) Standard Single Speed	65 or 100

**Dimensions listed are for minimum size "S" beam.



* ⚠ WARNING

Overloading and improper use can result in injury.

To avoid injury:

- Do not exceed working load limit, load rating capacity
- Do not use to lift people or loads over people.
- use only alloy chain for overhead lifting.
- Read and follow all instructions.

Lodestar XL with motor driven trolley (3-7½ ton)

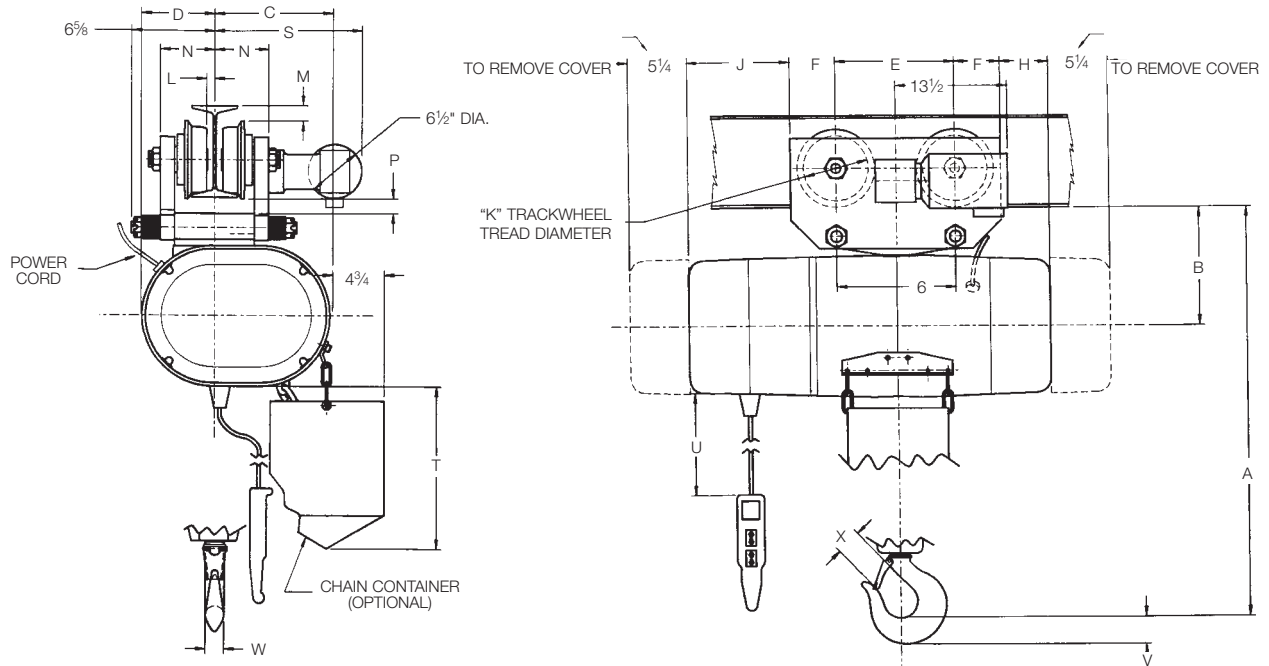

Clearance dimensions (in.)**

Dimensions	Double Reeved		Triple Reeved
	3 ton capacity	4 & 5 ton capacity	5-7½ ton capacity
A	33½	33¾	34⅝
B	10⅞	10⅞	10⅞
C	11⅞	11⅞	11⅞
D	5½	5½	5½
E	9⅞	12	12
F	3¼	4⅞	4⅞
H	5⅞	2⅞	2⅞
J	10½	7½	7½
K	4	6½	6½
L	⅝	⅝	⅝
M	2⅞	0	0
N	3⅞	3⅞	3⅞
P	⅜	⅞	⅞
S	11⅞	13⅞	13⅞
T (based on 10 ft. lift)	14⅞	14⅞	14⅞
U (based on 10 ft. lift)	6'- 3"	6'- 3"	6'- 3"
V	2¼	2¼	2¼
W	1⅝	1⅝	1⅝
X	2⅞	2⅞	2⅞
Minimum Radius Curve (ft.)	4	6	6
Standard Beam Flange Adj. Range (in.)	4.00-6.25	4.00-6.25	4.00-6.25
Trolley Speed (ft./min)			
Standard Single Speed	50	50	50

**Dimensions listed are for minimum size "S" beam.



ShopStar electric chain hoist



The ShopStar electric chain hoist features rugged construction and high H4 duty cycle. It keeps lifting and lifting, up to 1,000 pounds and 300 motor starts per hour. Additional features and benefits include:

- H4 duty cycle (300 motor starts/hour)
- Easy installation and maintenance
- Standard protector overload device
- 10 pocket oblique lay liftwheel provides longer chain wear
- Epoxy powder coat finish
- 6½ ft. power cord with molded 3 prong plug on 115 volt units
- NEMA 4 industrial rated control station
- Optional impact-resistant chain container available
- Gear train lifetime lubricated with non-oxidizing grease
- CM Hoist Alloy Load Chain (zinc plated optional)
- Thermally protected hoist duty motor
- Dual braking system — D.C. plus regenerative
- Rugged cast aluminum alloy hoist frame
- 5:1 design factor
- Small, compact design for commercial & industrial applications
- Rigid hook suspension prevents tangling of power cord
- Hardened forged steel latch style lower hook rotates 360°
- Totally enclosed non-ventilated hoist frame protects motor from environmental contamination
- True vertical lift
- Precision bearings used throughout hoist
- Lifetime warranty
- Made in U.S.A.

* WARNING

Overloading and improper use can result in injury.

To avoid injury:

- Do not exceed working load limit, load rating capacity
- Do not use to lift people or loads over people.
- Use only alloy chain for overhead lifting.
- Read and follow all instructions.

ShopStar-Specifications

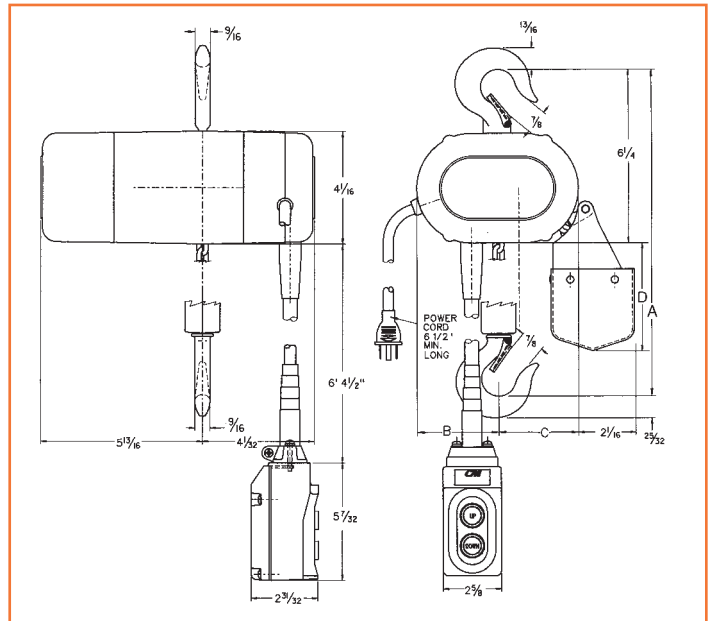

Clearance dimensions (in.)

Reeving	A	B	C	D
Single	11 ¹ / ₁₆	3	21 ⁵ / ₁₆	3 ⁷ / ₈
Double	11 ¹⁵ / ₁₆	3 ⁹ / ₁₆	2 ³ / ₈	5 ³ / ₄

Product code	Single reeved	Double reeved	Approx. Shipping wt., lbs.
2063	10	5	1
2064	20	10	1.4
2065	40	20	1.4
2066	80	40	1.4
2067	120	60	2.2

Specifications

Product Code				Max. capacity lbs.	Lifting speed F.P.M.	Reeving	Lift ft.	Approx. shipping wt., (lbs.)	Motor H.P
115-1-60	115-1-60	230-3-60	460-3-60						
2070	—	—	—	250	16	single	10	26	1/6
—	2069	2071	2072	250	16	single	10	28	1/6
—	—	2076	2077	250	24	single	10	28	1/6
—	—	2081	2082	250	40	single	10	28	1/6
2000	—	—	—	300	16	single	10	26	1/6
—	2047	2026	2029	300	16	single	10	28	1/6
—	—	2086	2087	300	24	single	10	28	1/6
—	—	2074	2075	300	40	single	10	28	1/6
2095	—	—	—	500	8	double	10	32	1/6
—	2094	2096	2097	500	8	double	10	34	1/6
2090	—	—	—	500	12	single	10	26	1/6
—	2089	2091	2092	500	12	single	10	28	1/6
—	—	2080	2084	500	16	single	10	28	1/6
—	—	2101	2102	500	20	double	10	34	1/6
—	—	2099	2100	500	24	single	10	28	1/6
2001	—	—	—	600	8	double	10	32	1/6
—	2048	2035	2038	600	8	double	10	34	1/6
—	—	2106	2107	600	12	double	10	34	1/6
—	—	2105	2114	600	20	double	10	34	1/6
2110	—	—	—	1000	6	double	10	32	1/6
—	2109	2111	2112	1000	6	double	10	34	1/6
—	—	2116	2117	1000	8	double	10	32	1/6
—	—	2119	2121	1000	12	double	10	32	1/6

*Codes in this column denote units with contactor in push button control station.

Valustar electric chain hoist



Designed specifically for general commercial applications. This compact, lightweight hoist features:

- Fully machined and heat treated liftwheel with hardened chain guides for smooth chain operation and reduced chain wear
- Standard lift 10, 15 & 20 ft.
- 5 ft. power cord length
- Heavy-duty caliper type AC brake
- Rugged NEMA 4 control station, 115 volt control circuit
- Easy to install and maintain
- Hoistaloy load chain for smooth operation and maximum chain life
- Efficient regenerative braking system to avoid heat generation in power train
- Enclosed hoist duty motor
- Gear train lifetime lubricated with non-oxidizing grease
- Latch type hooks
- Hook suspension standard
- Fully machined and heat treated gear train
- Standard overload Protector device
- H3 duty-1 phase; H-4 duty-3 phase
- One-year warranty
- Metric rated
- Made in U.S.A.

Specifications

	Product code		Model	Max. capacity tons	Hoist lifting speed FPM	Approximate shipping wt. (lbs.)	
	115-1-60	230/460 3-60				115-1-60	230/460 3-60
Single speed 10' lift	2401	2402	WB	1/4	16	54	58
	2403	2404	WF	1/2	16	60	58
	2405	2406	WH	1	8	70	68
	2407	2408	WL	1	16	105	106
	2409	2410	WR	2	8	130	122
Single speed 15' lift	2401B	2402B	WB	1/4	16	64	62
	2403B	2404B	WF	1/2	16	64	62
	2405B	2406B	WH	1	8	77	75
	2407B	2408B	WL	1	16	111	112
	2409B	2410B	WR	2	8	136	128
Single speed 20' lift	2401C	2402C	WB	1/4	16	68	66
	2403C	2404C	WF	1/2	16	68	66
	2405C	2406C	WH	1	8	84	82
	2407C	2408C	WL	1	16	116	117
	2409C	2410C	WR	2	8	150	142

Longer lifts and modifications available. Apply for details.

Valustar-Specifications

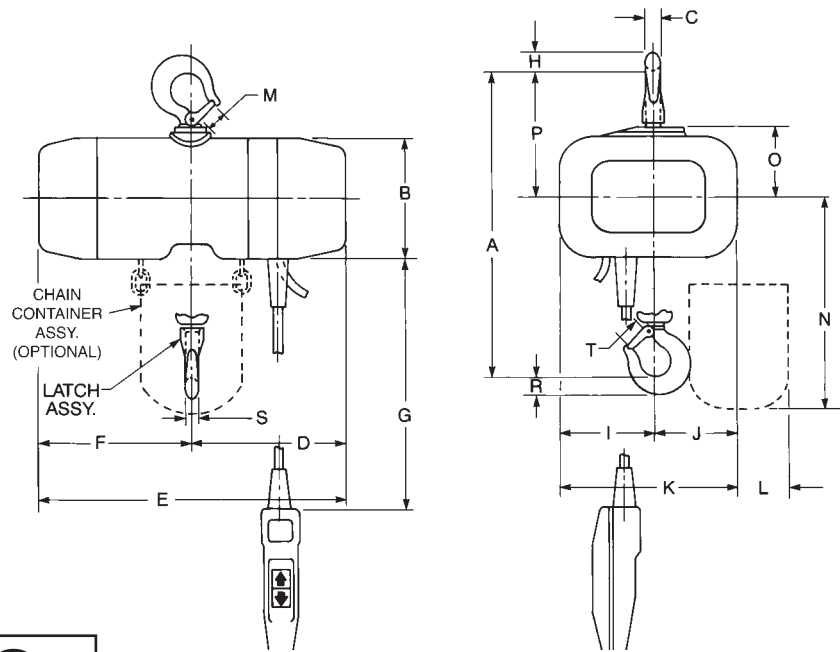

*** ⚠ WARNING**

Overloading and improper use can result in injury.

To avoid injury:

- Do not exceed working load limit, load rating capacity
- Do not use to lift people or loads over people.
- use only alloy chain for overhead lifting.
- Read and follow all instructions.

Clearance dimensions (in.)

Rated capacity* (tons)

Dimension	1/4	1/2	1/2	1	1/2	1	2
	Model WB	Model WF	Model WE	Model WH	Model WJ	Model WL	Model WR
A	14 1/4	14 1/4	17 7/8	17 7/8	15 9/16	15 9/16	22 1/2
B	6 1/8	6 1/8	6 1/8	6 1/8	7 5/8	7 5/8	7 5/8
C	1 1/16	1 1/16	7/8	7/8	7/8	7/8	1 1/8
D	8	8	8	8	9	9	9
E	16 1/16	16 1/16	16 1/16	16 1/16	20 3/16	20 3/16	20 3/16
F	8 1/16	8 1/16	8 1/16	8 1/16	11 3/16	11 3/16	11 3/16
G**	6'-3"	6'-3"	6'-3"	6'-3"	6'-3"	6'-3"	6'-3"
H	1	1	1 3/16	1 3/16	1 3/16	1 3/16	1 1/2
I	4 13/16	4 13/16	3 7/8	3 7/8	7 1/4	7 1/4	6 3/16
J	3 15/16	3 15/16	4 7/8	4 7/8	5 7/16	5 7/16	6 1/2
K	8 3/4	8 3/4	8 3/4	8 3/4	12 1 1/16	12 1 1/16	12 1 1/16
L	1 11/16	1 11/16	1 11/16	1 11/16	7/16	7/16	7/16
M	1	1	1 1/8	1 1/8	1 1/8	1 1/8	1 5/16
N**	12 15/16	12 15/16	15 15/16	15 15/16	16 1 1/16	16 1 1/16	22 1 1/16
O	3 9/16	3 9/16	3 9/16	3 9/16	4	4	4
P	6 3/16	6 3/16	6 1/2	6 1/2	6 7/8	6 7/8	7 3/8
R	1	1	1 3/16	1 3/16	1 3/16	1 3/16	1 1/2
S	1 1/16	1 1/16	7/8	7/8	7/8	7/8	1 1/8
T	1	1	1 1/8	1 1/8	1 1/8	1 1/8	1 5/16

** Based on 10 foot lift units

Powerstar electric chain hoist

Designed specifically as an alternative to wire rope hoists for high speed lifting of loads from 2 to 20 tons in a space saving chain hoist.

- H-4 or better rated duty cycle
- Designed for heavy-duty industrial applications from 2 to 20 ton capacities
- Liftwheel has machined chain pockets and is heat treated alloy steel for maximum strength and wear resistance
- Efficient regenerative braking system avoids heat generation in power train
- Motors up to 7 1/2 h.p. provide a wide range of lifting speeds
- Single or two speed controls. Two speed models operate on 3:1 speed ratio
- Standard adjustable upper and lower screw limit switches
- Standard overload Protector device
- Hoistaloy load chain can be easily inspected for wear and abuse
- True vertical lift
- Factory tested to 125% of rated capacity prior to shipment
- Metric rated except for 10 & 20 ton capacities
- Rugged aluminum alloy hoist frame
- Chain guide surrounds liftwheel
- Machined and hardened steel Helical gears used throughout hoist for optimum performance and mechanical efficiency.
- Extensive use of life-lubricated bearings plus sealed oil bath power train reservoir for minimum maintenance.
- Dual braking system
- Heavy duty, industrial single speed controls include magnetic reversing contactor which operates on 115 volts provided by a control transformer.
- Totally enclosed, ball bearing, 30 minute rated, thermally protected, hoist duty motor is standard.
- Push button control is weatherproof (NEMA 4 rated).
- Drop of push button control is 4 ft. above hook at lowest position, unless otherwise specified.
- External push button chain strain relief is standard.
- Power cord length is 2 1/2 ft. unless otherwise specified.
- Trolley design permits easy adjustment for installation on a broad range of beam flange widths.
- Trolley wheels have double row, tapered roller bearings plus machined and hardened universal treads to permit operation on American Standard or flat flanged sections interchangeably.
- Spur gearing used in all motorized trolleys for improved efficiency and durability.
- Drop of hand chain on geared trolleys is 2 ft. above hook at lowest position, unless otherwise specified.
- Designed to be maintained "on the beam."
- Up to 600 lineal feet of chain
- Weatherproof (NEMA3R)
- Lifetime warranty
- Made in U.S.A.

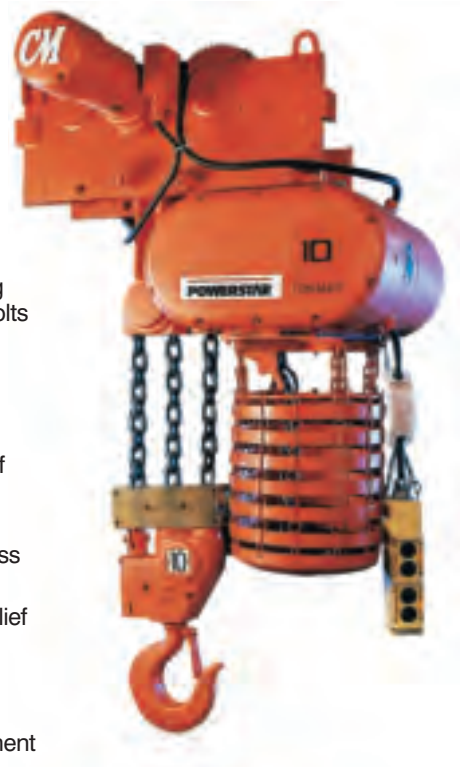

* **WARNING**

Overloading and improper use can result in injury.

To avoid injury:

- Do not exceed working load limit, load rating capacity
- Do not use to lift people or loads over people.
- use only alloy chain for overhead lifting.
- Read and follow all instructions.

Powerstar-Specifications

Specifications – standard unit

Rated capacity* (tons)	Single speed		Two speed			Reeving (single)	Std. lift** (ft.)	HP	Headroom w/lug suspension (in.)	Headroom w/trolley suspension (in.)	Hoist only approx. shipping weight		
	Lifting speed (F.P.M.)	Product code 230-3-60	Product code 460-3-60	Lifting speed (F.P.M.)	Product code 230-3-60						Product code 460-3-60	Single speed hoist (lbs.)	Two speed hoist (lbs.)
2	20	7300	7301	20/7	7302	7303	1	20	5	28 ¹⁵ / ₁₆	30 ¹⁵ / ₁₆	392	402
	24	7001	7002	24/8	7003	7004	1	20	5	28 ¹⁵ / ₁₆	30 ¹⁵ / ₁₆	392	402
	32	7304	7305	32/11	7306	7037	1	20	5	28 ¹⁵ / ₁₆	30 ¹⁵ / ₁₆	404	414
	40	7005	7006	40/13	7007	7008	1	20	5	28 ¹⁵ / ₁₆	30 ¹⁵ / ₁₆	404	414
	48	7308	7309	48/16	7310	7311	1	20	7.5	28 ¹⁵ / ₁₆	30 ¹⁵ / ₁₆	408	418
3	20	7312	7313	20/7	7314	7315	1	20	5	28 ¹⁵ / ₁₆	31 ¹ / ₂	404	414
	24	7009	7010	24/8	7011	7012	1	20	5	28 ¹⁵ / ₁₆	31 ¹ / ₂	404	414
	32	7316	7317	32/11	7318	7319	1	20	7.5	28 ¹⁵ / ₁₆	31 ¹ / ₂	408	418
	40	7013	7014	40/13	7015	7016	1	20	7.5	28 ¹⁵ / ₁₆	31 ¹ / ₂	408	418
4	10	7320	7321	10/3	7322	7323	2	20	5	34	36 ⁹ / ₁₆	478	488
	12	7324	7325	12/4	7326	7327	2	20	5	34	36 ⁹ / ₁₆	490	500
	16	7328	7329	16/5	7330	7331	2	20	5	34	36 ⁹ / ₁₆	490	500
	20	7332	7333	20/7	7334	7335	2	20	7.5	34	36 ⁹ / ₁₆	490	500
	24	7336	7337	24/8	7338	7339	2	20	7.5	34	36 ⁹ / ₁₆	494	504
5	10	7340	7341	10/3	7342	7343	2	20	5	34	36 ⁹ / ₁₆	478	488
	12	7344	7345	12/4	7346	7347	2	20	5	34	36 ⁹ / ₁₆	478	488
	16	7029	7030	16/5	7031	7032	2	20	5	34	36 ⁹ / ₁₆	490	500
	20	7348	7349	20/7	7350	7351	2	20	7.5	34	36 ⁹ / ₁₆	494	500
	24	7017	7018	24/8	7019	7020	2	20	7.5	34	36 ⁹ / ₁₆	494	504
6	10	7352	7353	10/3	7354	7355	2	20	5	34	36 ⁹ / ₁₆	548	558
	12	7052	7053	12/4	7054	7055	2	20	5	34	36 ⁹ / ₁₆	548	558
	16	7356	7357	16/5	7358	7359	2	20	7.5	34	36 ⁹ / ₁₆	552	562
	20	7056	7057	20/7	7058	7059	2	20	7.5	34	36 ⁹ / ₁₆	552	562
7 ¹ / ₂	7	7360	7361	7/2	7362	7363	3	20	5	Apply	39 ³ / ₈	594	604
	8	7364	7365	8/3	7366	7367	3	20	5	Apply	39 ³ / ₈	606	616
	11	7368	7369	11/4	7370	7371	3	20	5	Apply	39 ³ / ₈	606	616
	14	7372	7373	14/5	7374	7375	3	20	7.5	Apply	39 ³ / ₈	622	632
	16	7376	7377	16/5	7378	7379	3	20	7.5	Apply	39 ³ / ₈	622	632
9	7	7380	7381	7/2	7382	7383	3	20	5	Apply	41 ³ / ₁₆	610	620
	8	7384	7385	8/3	7386	7387	3	20	5	Apply	41 ³ / ₁₆	610	620
	11	7388	7389	11/4	7390	7391	3	20	7.5	Apply	41 ³ / ₁₆	626	636
	13	7392	7393	13/4	7394	7395	3	20	7.5	Apply	41 ³ / ₁₆	626	636
10	7	7396	7397	7/2	7398	7399	3	20	5	Apply	41 ³ / ₁₆	610	620
	8	7400	7401	8/3	7402	7403	3	20	5	Apply	41 ³ / ₁₆	610	620
	11	7404	7405	11/4	7406	7407	3	20	7.5	Apply	41 ³ / ₁₆	626	636
	13	7408	7409	13/4	7410	7411	3	20	7.5	Apply	41 ³ / ₁₆	626	636
12	5	7412	7413	5/2	7414	7415	4	20	5	Apply	41 ³ / ₁₆	710	720
	6	7416	7417	6/2	7418	7419	4	20	5	Apply	41 ³ / ₁₆	710	720
	8	7420	7421	8/3	7422	7423	4	20	7.5	Apply	41 ³ / ₁₆	726	736
	10	7424	7425	10/3	7426	7427	4	20	7.5	Apply	41 ³ / ₁₆	726	736
15	4	7428	7429	4/1.3	7430	7431	5	20	5	Apply	47 ⁵ / ₁₆	805	815
	5	7432	7433	5/1.5	7434	7435	5	20	5	Apply	47 ⁵ / ₁₆	805	815
	6	7436	7437	6/2	7438	7439	5	20	7.5	Apply	47 ⁵ / ₁₆	817	827
	8	7440	7441	8/2.5	7442	7443	5	20	7.5	Apply	47 ⁵ / ₁₆	817	827

** 20 ft. lift is standard — for other lifts, apply.

Powerstar with lug suspension

2, 3, 4, 5 & 6 ton capacities (for 7½ - 15 ton capacities, consult factory)

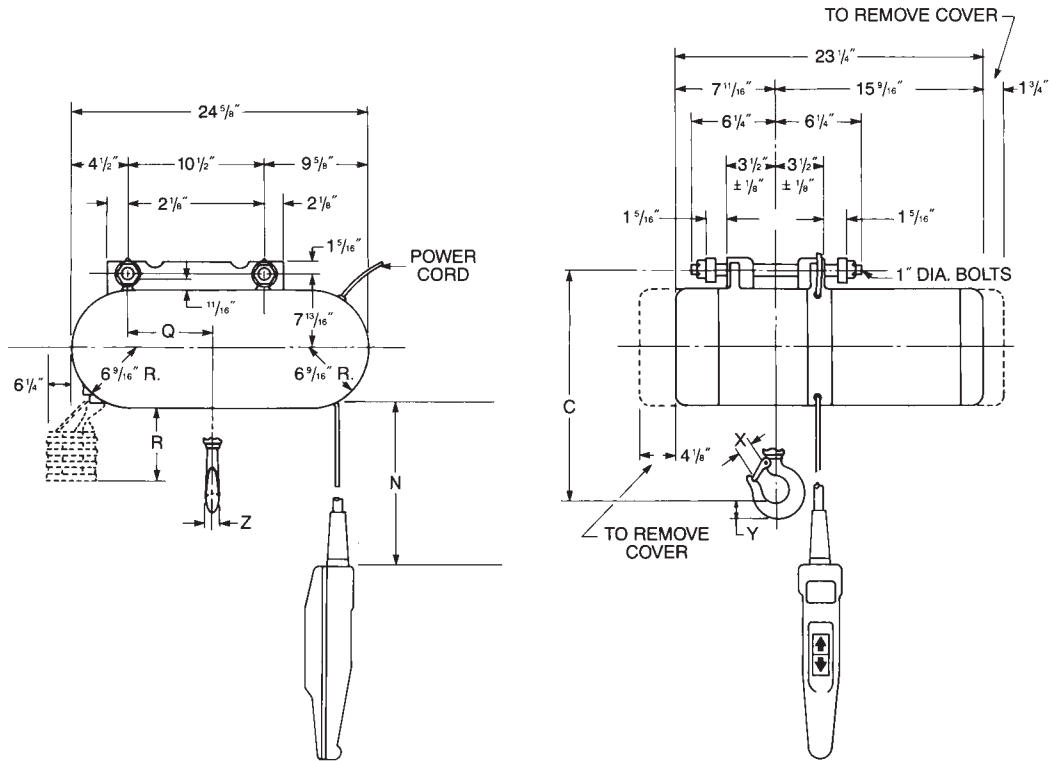

Clearance dimensions (in.)

Dimension	Rated capacity* (tons)				
	2	3	4	5	6
C	28 ¹⁵ / ₁₆	28 ¹⁵ / ₁₆	34	34	34
N**	16'-7"	16'-7"	16'-7"	16'-7"	16'-7"
Q	3 ³ / ₄	3 ³ / ₄	5 ⁷ / ₈	5 ⁷ / ₈	5 ⁷ / ₈
R**	18 ¹ / ₁₆	18 ¹ / ₁₆	26 ³ / ₁₆	26 ³ / ₁₆	26 ³ / ₁₆
X	1 ⁵ / ₈	1 ⁵ / ₈	2 ⁵ / ₁₆	2 ⁵ / ₁₆	2 ⁵ / ₁₆
Y	1 ¹ / ₁₆	1 ¹ / ₁₆	2 ⁹ / ₁₆	2 ⁹ / ₁₆	2 ⁹ / ₁₆
Z	1 ¹ / ₄	1 ¹ / ₄	1 ¹³ / ₁₆	1 ¹³ / ₁₆	1 ¹³ / ₁₆

**Applies to 20 foot lift units

All dimensions are in inches and are based on minimum American standard section.

*** ⚠ WARNING**

Overloading and improper use can result in injury.

To avoid injury:

- Do not exceed working load limit, load rating capacity
- Do not use to lift people or loads over people.
- use only alloy chain for overhead lifting.
- Read and follow all instructions.

Powerstar with plain or geared trolley

2, 3, 4, 5 & 6 ton capacities

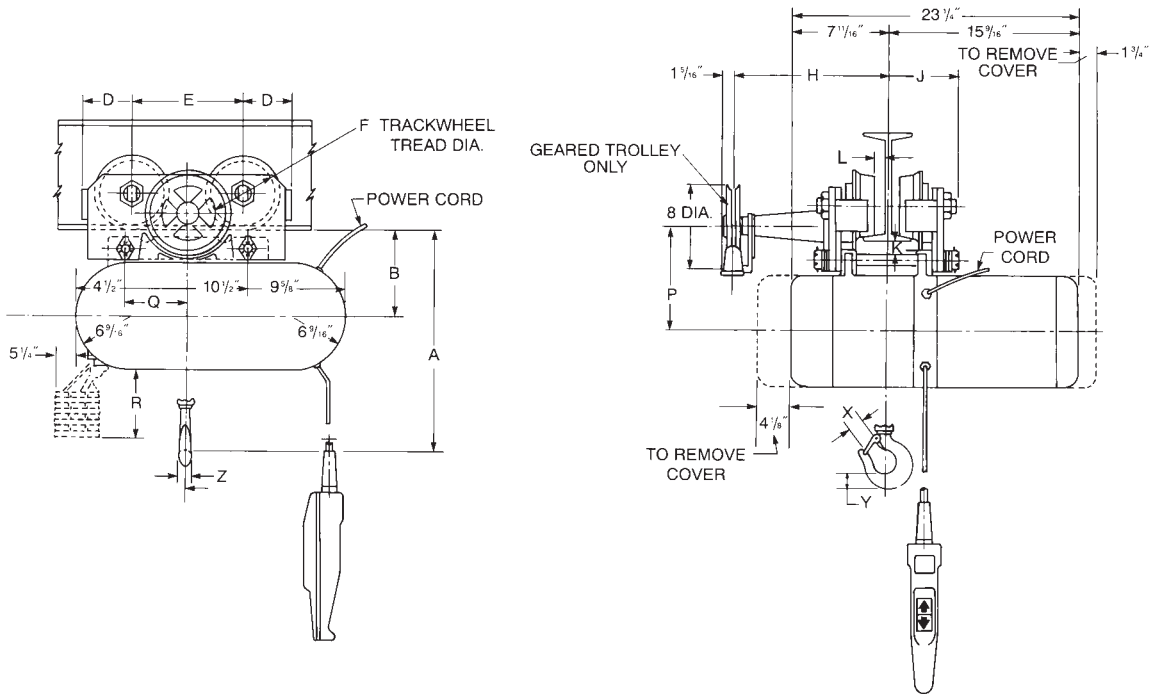

Clearance dimensions (in.)

Dimension	Rated capacity* (tons)				
	2	3	4	5	6
A	30 ¹⁵ / ₁₆	31 1/2	36 ⁹ / ₁₆	36 ⁹ / ₁₆	36 ⁹ / ₁₆
B	9 ¹³ / ₁₆	10 ³ / ₈	10 ³ / ₈	10 ³ / ₈	10 ³ / ₈
D	3 1/2	4 ⁹ / ₁₆	4 ⁹ / ₁₆	4 ⁹ / ₁₆	4 ⁹ / ₁₆
E	9 1/2	10 1/2	10 1/2	10 1/2	10 1/2
F	4 ¹¹ / ₁₆	5 ¹³ / ₁₆	5 ¹³ / ₁₆	5 ¹³ / ₁₆	5 ¹³ / ₁₆
H	12 ¹³ / ₁₆	14 1/8	14 1/8	14 1/8	14 1/8
J	5	6 1/4	6 1/4	6 1/4	6 1/4
K	1 ¹ / ₁₆	1 1/4	1 1/4	1 1/4	1 1/4
L	1/2	1 ⁵ / ₁₆	1 ⁵ / ₁₆	1 ⁵ / ₁₆	1 ⁵ / ₁₆
P	11 ⁹ / ₁₆	11 ¹⁵ / ₁₆	11 ¹⁵ / ₁₆	11 ¹⁵ / ₁₆	11 ¹⁵ / ₁₆
Q	3 3/4	3 3/4	5 ⁷ / ₈	5 ⁷ / ₈	5 ⁷ / ₈
R**	18 ¹ / ₁₆	18 ¹ / ₁₆	26 ³ / ₁₆	26 ³ / ₁₆	26 ³ / ₁₆
X	1 ⁵ / ₈	1 ⁵ / ₈	2 ⁵ / ₁₆	2 ⁵ / ₁₆	2 ⁵ / ₁₆
Y	1 ¹ / ₁₆	1 ¹ / ₁₆	2 ⁹ / ₁₆	2 ⁹ / ₁₆	2 ⁹ / ₁₆
Z	1 1/4	1 1/4	1 ¹³ / ₁₆	1 ¹³ / ₁₆	1 ¹³ / ₁₆

**Std. 20 foot lift

All dimensions are in inches and are based on minimum American standard section.

Specifications

Rated capacity* (tons)	Plain trolley		Geared trolley†		Std. range of adjust. Am. std. S-beams		Min. radius curve (in.)
	Product code	Shipping weight (lbs.)	Product code	Shipping weight (lbs.)	Min. beam size	Max. beam size	
2	5973	98	5964	175	S6 x 12.5# x 3.33"	S15 x 42.9# x 5.5"	48
3-6	5971	176	5972	295	S12 x 31.8# x 5"	S20 x 65.4# x 6.25"	66

† Standard hand chain drop is in proportion to 20 ft. lift. For other lifts, apply to the factory.

Powerstar with motor driven trolley

2, 3, 4, 5 & 6 ton capacities

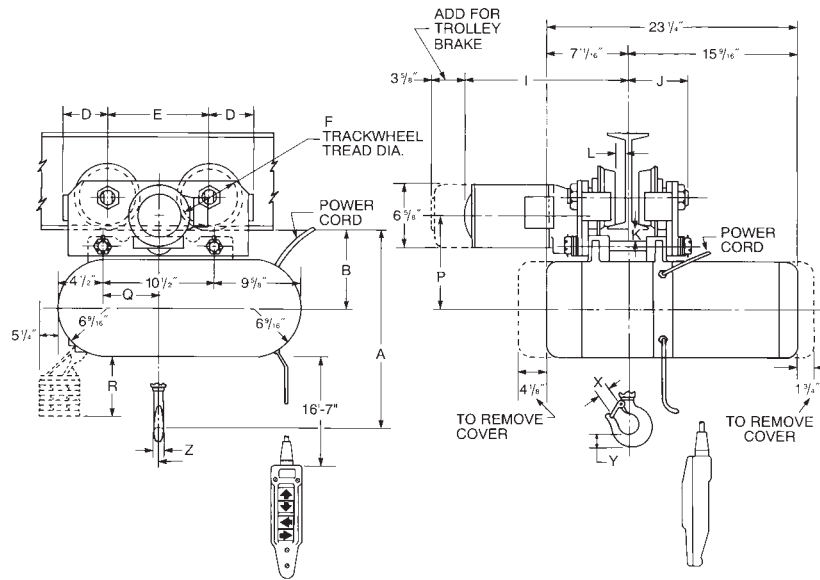

Clearance dimensions (in.)

Dimension	Rated capacity* (tons)				
	2	3	4	5	6
A	30 ¹⁵ / ₁₆	31 ¹ / ₂	36 ⁹ / ₁₆	36 ⁹ / ₁₆	36 ⁹ / ₁₆
B	9 ¹³ / ₁₆	10 ³ / ₈	10 ³ / ₈	10 ³ / ₈	10 ³ / ₈
D	3 ¹ / ₂	4 ⁹ / ₁₆	4 ⁹ / ₁₆	4 ⁹ / ₁₆	4 ⁹ / ₁₆
E	9 ¹ / ₂	10 ¹ / ₂	10 ¹ / ₂	10 ¹ / ₂	10 ¹ / ₂
F	4 ¹¹ / ₁₆	5 ¹³ / ₁₆	5 ¹³ / ₁₆	5 ¹³ / ₁₆	5 ¹³ / ₁₆
I	17 ⁷ / ₁₆	18 ⁵ / ₈	18 ⁵ / ₈	18 ⁵ / ₈	18 ⁵ / ₈
J	5	6 ¹ / ₄	6 ¹ / ₄	6 ¹ / ₄	6 ¹ / ₄
K	1 ¹ / ₁₆	1 ¹ / ₄	1 ¹ / ₄	1 ¹ / ₄	1 ¹ / ₄
L	1/2	1 ⁵ / ₁₆	1 ⁵ / ₁₆	1 ⁵ / ₁₆	1 ⁵ / ₁₆
P	11 ⁹ / ₁₆	11 ¹⁵ / ₁₆	11 ¹⁵ / ₁₆	11 ¹⁵ / ₁₆	11 ¹⁵ / ₁₆
Q	3 ³ / ₄	3 ³ / ₄	5 ⁷ / ₈	5 ⁷ / ₈	5 ⁷ / ₈
R**	18 ¹ / ₁₆	18 ¹ / ₁₆	26 ³ / ₁₆	26 ³ / ₁₆	26 ³ / ₁₆
X	1 ⁵ / ₈	1 ⁵ / ₈	2 ⁵ / ₁₆	2 ⁵ / ₁₆	2 ⁵ / ₁₆
Y	1 ¹ / ₁₆	1 ¹ / ₁₆	2 ⁹ / ₁₆	2 ⁹ / ₁₆	2 ⁹ / ₁₆
Z	1 ¹ / ₄	1 ¹ / ₄	1 ¹³ / ₁₆	1 ¹³ / ₁₆	1 ¹³ / ₁₆

**Applies to 20 foot lift units

All dimensions are in inches and are based on minimum American standard section

Specifications — trolley

Rated capacity* (tons)	Speed (F.P.M.)	Product code		Approx. shipping weight (lbs.)	Standard range of adjustability Am. std. S-beam		Min. radius curve (in.)
		230-3-60	460-3-60		Min. beam size	Max. beam size	
2	65	7064	7065	168	S6 x 12.5# x 3.33"	S15 x 42.9# x 5.5"	48
2	100	7066	7067	168	S6 x 12.5# x 3.33"	S15 x 42.9# x 5.5"	48
3	50	7068	7069	250	S12 x 31.8# x 5"	S20 x 66# x 6.25"	66
4	50	7545	7585	255	S12 x 31.8# x 5"	S20 x 66# x 6.25"	66
5	50	7070	7071	255	S12 x 31.8# x 5"	S20 x 66# x 6.25"	66
6	50	7072	7073	255	S12 x 31.8# x 5"	S20 x 66# x 6.25"	66

Apply for other than standard trolley speeds and for other than standard beam adjustment

Powerstar with plain or geared trolley

7½, 9, 10, 12 & 15 ton capacities

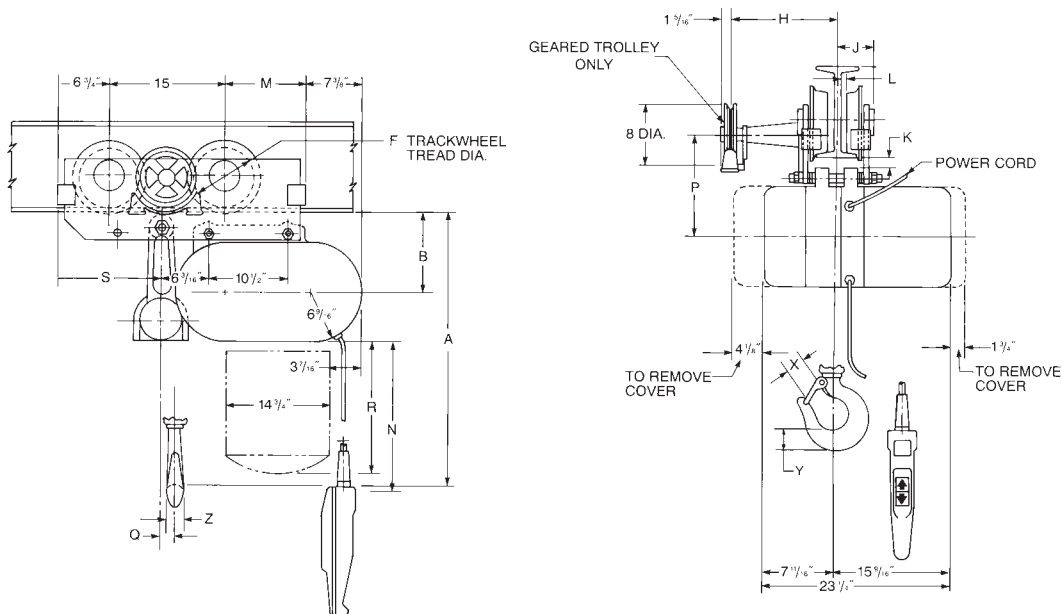

Clearance dimensions (in.)

Dimension	Rated capacity* (tons)				
	7½	9	10	12	15
A	39 ³ / ₈	41 ³ / ₁₆	41 ³ / ₁₆	41 ³ / ₁₆	47 ¹⁵ / ₁₆
B	11 ¹³ / ₁₆	11 ¹³ / ₁₆	11 ¹³ / ₁₆	11 ⁹ / ₁₆	11 ⁹ / ₁₆
F	8	8	8	8	8
H	14	14¼	14¼	14 ³ / ₄	13 ¹³ / ₁₆
J	5½	5 ³ / ₈	5 ³ / ₈	5 ⁷ / ₈	5 ⁷ / ₈
K	1½	1 ⁷ / ₁₆	1 ⁷ / ₁₆	1¼	1¼
L	¾	1 ⁵ / ₁₆	1 ⁵ / ₁₆	1 ¹ / ₁₆	1 ¹ / ₁₆
M	10 ³ / ₄	10 ³ / ₄	10 ³ / ₄	10 ³ / ₄	13 ³ / ₁₆
N**	17'-10"	17'-10"	17'-10"	17'-10"	17'-10"
P	16 ⁵ / ₁₆	16 ⁵ / ₁₆	16 ⁵ / ₁₆	16 ⁵ / ₁₆	16 ⁵ / ₁₆
Q	1 ⁵ / ₁₆	1 ⁵ / ₁₆	1 ⁵ / ₁₆	0	-1 ¹³ / ₁₆
R**	21½	21½	21½	26 ¹ / ₈	31 ¹ / ₈
S	12 ¹³ / ₁₆	12 ¹³ / ₁₆	12 ¹³ / ₁₆	12 ¹³ / ₁₆	16 ¹ / ₆
X	2 ⁵ / ₁₆	3	3	3	3 ⁵ / ₈
Y	2 ⁹ / ₁₆	3	3	3	3 ⁵ / ₈
Z	1 ¹³ / ₁₆	2 ³ / ₈	2 ³ / ₈	2 ³ / ₈	3

**Applies to 20 foot lift units

All dimensions are in inches and are based on minimum American standard section.

Specifications

Rated capacity* (tons)	Plain trolley		Geared trolley†		Std. range of adjust. Am. std. S-beams		Min. radius curve (in.)
	Product code	Shipping weight (lbs.)	Product code	Shipping weight (lbs.)	Min. beam size	Max. beam size	
7½	7205	335	7209	395	S15 x 42.9# x 5.5"	S24 x 100# x 7.25"	120
9	7206	335	7210	395	S18 x 54.7# x 6"	S24 x 121# x 8"	120
10	7207	335	7211	395	S18 x 54.7# x 6"	S24 x 121# x 8"	120
12	7208	335	7212	395	S20 x 86# x 7"	S24 x 121# x 8"	120
15	7530	350	7532	410	S20 x 86# x 7"	S24 x 121# x 8"	120

† Standard hand chain drop is in proportion to 20 ft. lift. For other chain drops, apply to factory.

Powerstar with motor driven trolley

7½, 9, 10, 12 & 15 ton capacities

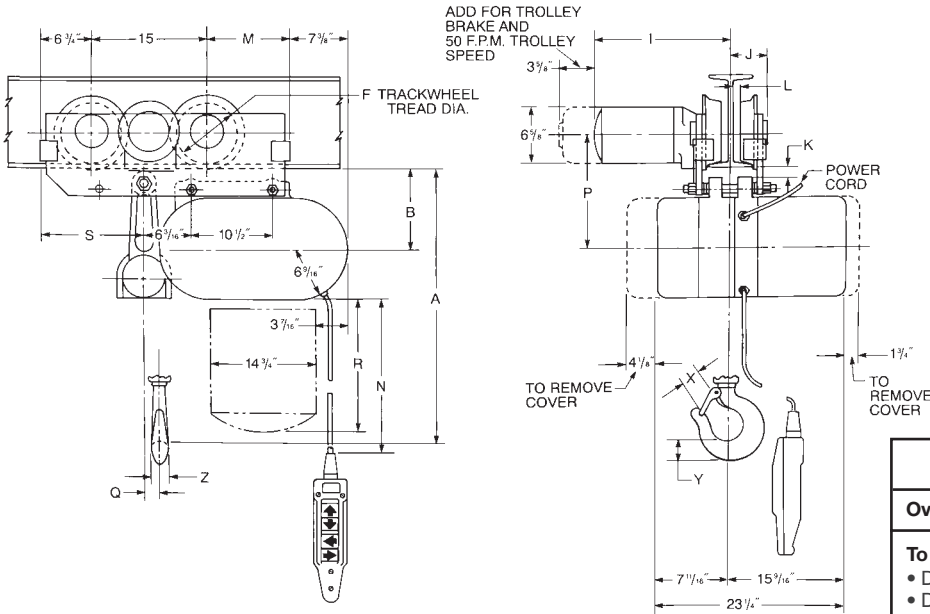

*** ⚠ WARNING**

Overloading and improper use can result in injury.

To avoid injury:

- Do not exceed working load limit, load rating capacity
- Do not use to lift people or loads over people.
- use only alloy chain for overhead lifting.
- Read and follow all instructions.

Clearance dimensions (in.)

Dimension	Rated capacity* (tons)				
	7½	9	10	12	15
A	39 ³ / ₈	41 ³ / ₁₆	41 ³ / ₁₆	41 ³ / ₁₆	47 ¹⁵ / ₁₆
B	11 ¹³ / ₁₆	11 ¹³ / ₁₆	11 ¹³ / ₁₆	11 ⁹ / ₁₆	11 ⁹ / ₁₆
F	8	8	8	8	8
I	18	18 ¹ / ₄	18 ¹ / ₄	19 ⁵ / ₈	18 ⁷ / ₁₆
J	5 ¹ / ₈	5 ³ / ₈	5 ³ / ₈	5 ⁷ / ₈	5 ⁷ / ₈
K	1 ¹ / ₂	1 ⁷ / ₁₆	1 ⁷ / ₁₆	1 ¹ / ₄	1 ¹ / ₄
L	¾	1 ⁵ / ₁₆	1 ⁵ / ₁₆	1 ¹ / ₁₆	1 ¹ / ₁₆
M	10 ³ / ₄	10 ³ / ₄	10 ³ / ₄	10 ³ / ₄	13 ³ / ₁₆
N**	17'-10"	17'-10"	17'-10"	17'-10"	17'-10"
P	16 ⁵ / ₁₆	16 ⁵ / ₁₆	16 ⁵ / ₁₆	16 ⁵ / ₁₆	16 ⁵ / ₁₆
Q	1 ⁵ / ₁₆	1 ⁵ / ₁₆	1 ⁵ / ₁₆	0	-1 ³ / ₁₆
R**	21 ¹ / ₂	21 ¹ / ₂	21 ¹ / ₂	26 ¹ / ₈	31 ¹ / ₈
S	12 ¹³ / ₁₆	12 ¹³ / ₁₆	12 ¹³ / ₁₆	12 ¹³ / ₁₆	16 ¹ / ₁₆
X	2 ⁵ / ₁₆	3	3	3	3 ⁵ / ₈
Y	2 ⁹ / ₁₆	3	3	3	3 ⁵ / ₈
Z	1 ¹³ / ₁₆	2 ³ / ₈	2 ³ / ₈	2 ³ / ₈	3

**Applies to 20 foot lift units.

All dimensions are in inches and are based on minimum American standard section

Specifications — trolley

Rated capacity* (tons)	Speed (F.P.M.)	Product code		Approx. shipping weight (lbs.)	Standard range of adjustability Am. std. S-beams		Min. radius curve (in.)
		230-3-60	460-3-60		Min. beam size	Max. beam size	
7½	35	7224	7224	390	S15 x 42.9# x 5.5"	S24 x 100# x 7.25"	120
9	35	7225	7225	390	S18 x 54.7# x 6"	S24 x 121# x 8"	120
10	35	7226	7226	390	S18 x 54.7# x 6"	S24 x 121# x 8"	120
12	35	7227	7227	390	S20 x 86# x 7"	S24 x 121# x 8"	120
15	35	7571	7299	405	S20 x 86# x 7"	S24 x 121# x 8"	120

Apply for other than standard trolley speeds and other than standard beam adjustment

Polaris wire rope hoist

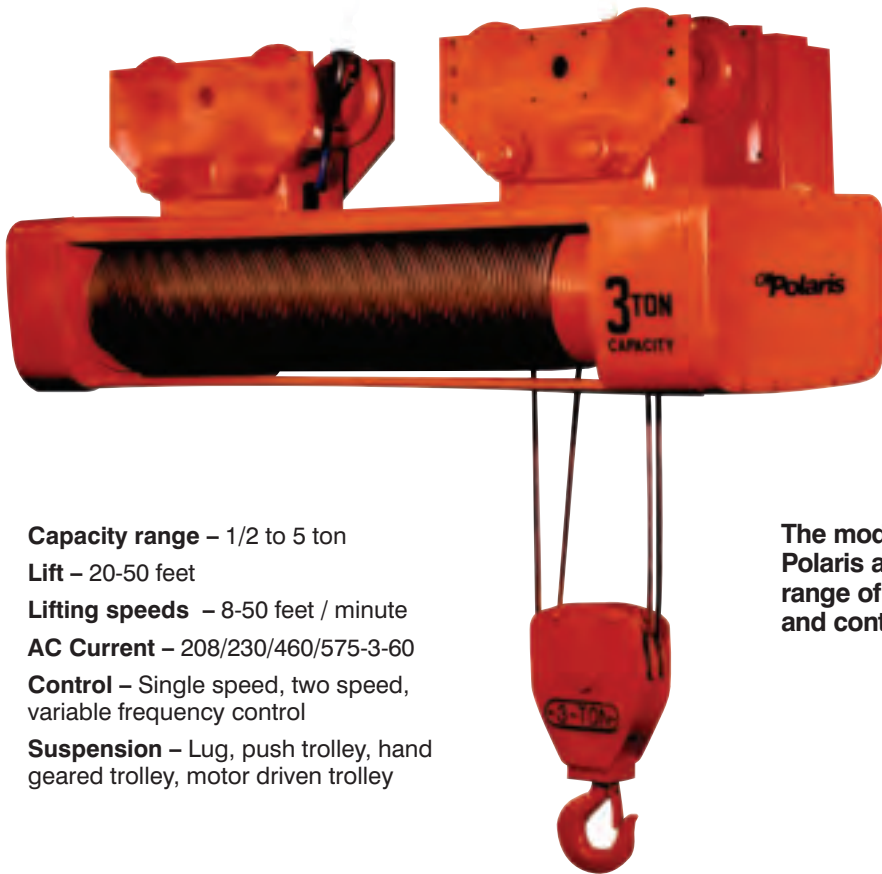

Capacity range – 1/2 to 5 ton
Lift – 20-50 feet
Lifting speeds – 8-50 feet / minute
AC Current – 208/230/460/575-3-60
Control – Single speed, two speed, variable frequency control
Suspension – Lug, push trolley, hand geared trolley, motor driven trolley

The modular design and versatility of the Polaris allow users to select from a wide range of capacities, lifts, hoisting speeds and control options.

- Compact design and close end approaches provide high hook lift
- Steel mounting lug is integral to one-piece welded frame
- Totally enclosed oil bath lubricated drive train
- Easily accessible control enclosure
- D.C. disc. motor brake provides smooth braking action
- Oil level plug permits easy inspection of oil level
- Deep grooved large diameter rope drum helps prevent rope overwrap for longer wire rope life
- High-torque, heavy-duty hoist motor for smooth hoisting action
- Anti-friction bearings throughout for long lasting hoist drive
- Triple reduction helical/spur gearing operates in oil bath lube for maximum gearing life
- Made in U.S.A.

* WARNING

Overloading and improper use can result in injury.

To avoid injury:

- Do not exceed working load limit, load rating capacity
- Do not use to lift people or loads over people.
- use only alloy chain for overhead lifting.
- Read and follow all instructions.



Polaris hoist with lug suspension

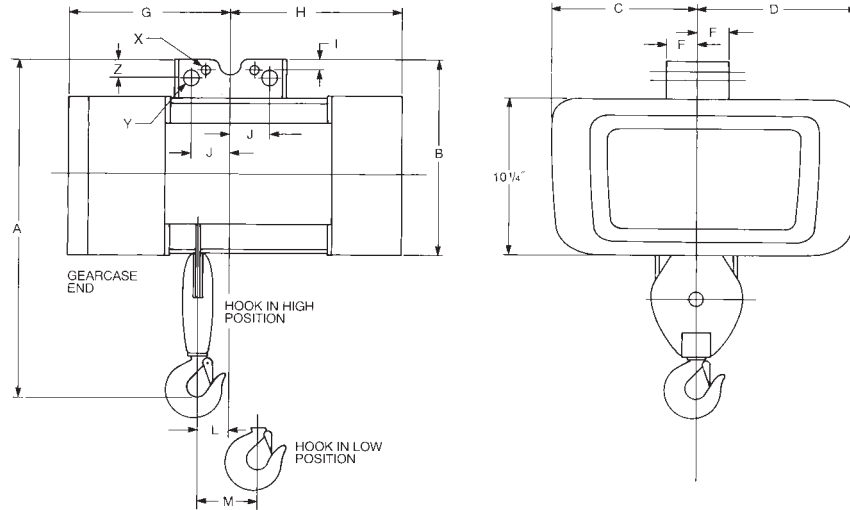
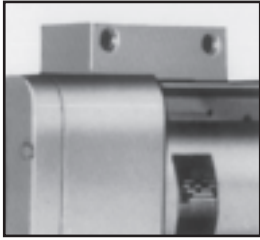

Clearance dimensions (in.)

Rated capacity* (tons)	A	B	C	D	F	G	H	I	J	L	M	X	Y	Z
1	21 ³ / ₄	12 ⁵ / ₈	9 ³ / ₈	10 ¹ / ₄	2	10 ⁵ / ₈	11 ¹ / ₈	1 ¹ / ₁₆	2 ¹ / ₂	2	3 ⁷ / ₈	2 ¹ / ₃₂	1 ¹ / ₃₂	1 ³ / ₁₆
2	23 ¹ / ₂	12 ⁵ / ₈	9 ³ / ₈	10 ¹ / ₄	2	10 ⁵ / ₈	11 ¹ / ₈	1 ¹ / ₁₆	2 ¹ / ₂	2	3 ⁷ / ₈	2 ¹ / ₃₂	1 ¹ / ₃₂	1 ³ / ₁₆
3	26	13 ⁵ / ₈	9 ¹ / ₈	10 ¹ / ₂	3	12 ¹ / ₂	22 ³ / ₈	1 ⁵ / ₁₆	3	1 ¹ / ₃₂	5 ³ / ₈	—	1 ⁹ / ₃₂	—
5	27 ³ / ₄	13 ⁵ / ₈	9 ¹ / ₈	10 ¹ / ₂	3	12 ¹ / ₂	22 ⁵ / ₈	1 ⁵ / ₁₆	3	7 ⁷ / ₈	3 ¹ / ₂	—	1 ⁹ / ₃₂	—

Specifications

Product code	Rated capacity* (tons)	Lift (ft.)	Speed (F.P.M.)	H.P.	Rope no. & dia.	Net weight (lbs.)
6000L	1	25	16	1	2 1/4	190
6004L	2	20	16	2	2 5/16	220
6008L	3	30	16	4	4 5/16	335
6016L	5	20	12	4	6 5/16	355

* WARNING

Overloading and improper use can result in injury.

To avoid injury:

- Do not exceed working load limit, load rating capacity
- Do not use to lift people or loads over people.
- use only alloy chain for overhead lifting.
- Read and follow all instructions.

Polaris hoist with plain push trolley

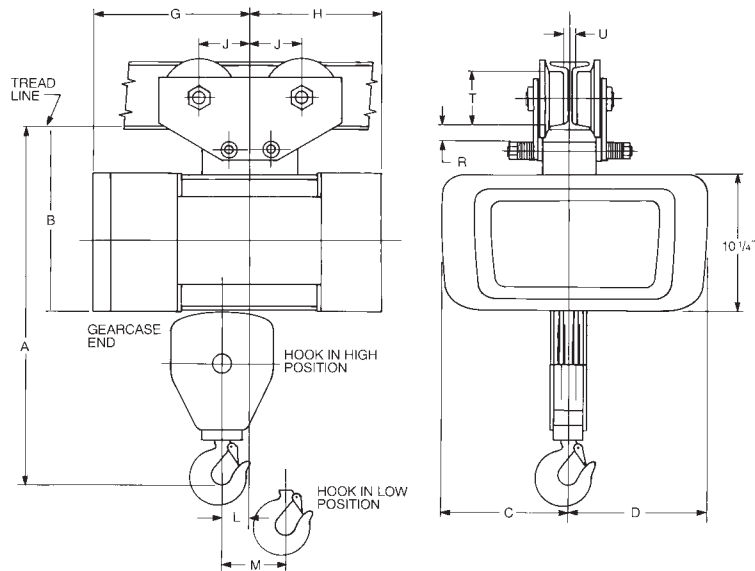
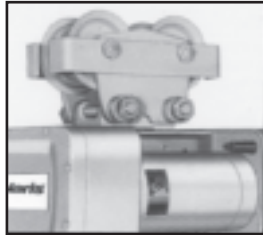

Clearance dimensions (in.)

Rated capacity* (tons)	A	B	C	D	G	H	J	L	M	R	T	U
1	22 ¹⁵ / ₁₆	13 ¹³ / ₁₆	9 ³ / ₈	10 ¹ / ₄	10 ⁵ / ₈	11 ¹ / ₈	3 ¹ / ₈	2	3 ⁷ / ₈	1 ⁵ / ₃₂	4	1 ¹ / ₄
2	24 ⁵ / ₁₆	13 ⁷ / ₁₆	9 ³ / ₈	10 ¹ / ₄	10 ⁵ / ₈	11 ¹ / ₈	3 ⁷ / ₁₆	2	3 ⁷ / ₈	1 ³ / ₁₆	4 ¹⁵ / ₁₆	1 ³ / ₁₆
3	27 ³ / ₁₆	14 ⁵ / ₈	9 ¹ / ₈	10 ¹ / ₂	12 ¹ / ₂	22 ³ / ₈	6	1 ¹ / ₃₂	5 ³ / ₈	1 ³ / ₁₆	6 ¹ / ₂	1
5	29 ¹ / ₁₆	14 ¹⁵ / ₁₆	9 ¹ / ₈	10 ¹ / ₂	12 ¹ / ₂	22 ³ / ₈	6	7/ ₈	3 ¹ / ₂	1 ⁵ / ₁₆	6 ¹ / ₂	1

Specifications

Product code	Rated capacity* (tons)	Lift (ft.)	Speed (F.P.M.)	H.P.	Rope no. & dia.	Net weight (lbs.)
6000P	1	25	16	1	2 1/4	213
6004P	2	20	16	2	2 5/16	263
6008P	3	30	16	4	4 5/16	475
6016P	5	20	12	4	6 5/16	495

Trolley flange range width 1 ton 3" min., 5" max.; 2 ton 3⁵/₈" min., 6" max.; 3-5 ton 4" min., 6¹/₄" max.

* WARNING

Overloading and improper use can result in injury.

To avoid injury:

- Do not exceed working load limit, load rating capacity
- Do not use to lift people or loads over people.
- use only alloy chain for overhead lifting.
- Read and follow all instructions.

Polaris hoist with hand geared trolley

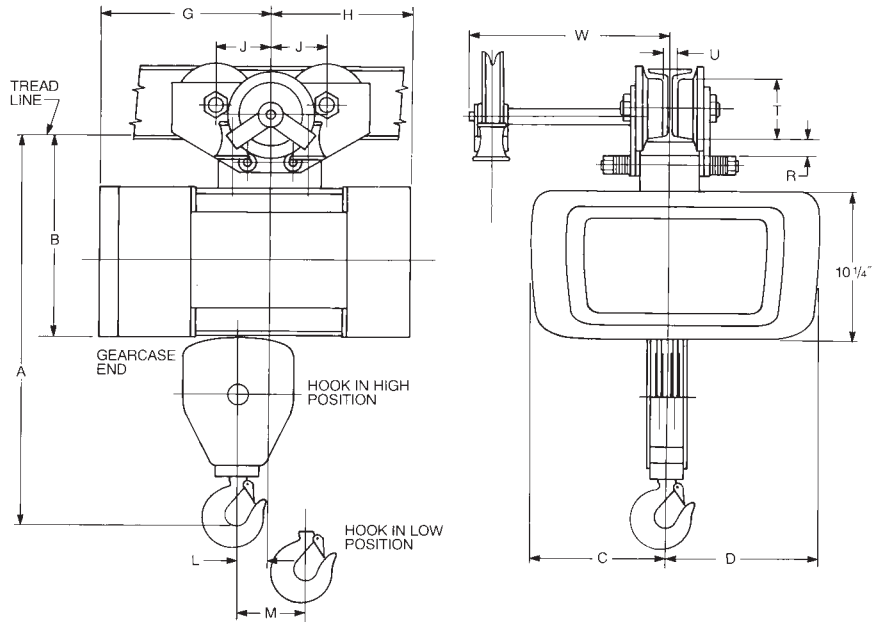
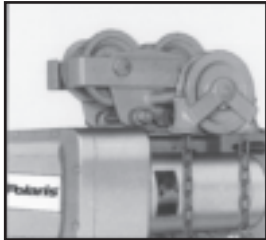

Clearance dimensions (in.)

Rated capacity* (tons)	A	B	C	D	G	H	J	L	M	R	T	U	W
1	22 ¹⁵ / ₁₆	13 ¹³ / ₁₆	9 ³ / ₈	10 ¹ / ₄	10 ⁵ / ₈	11 ¹ / ₈	3 ¹ / ₈	2	3 ⁷ / ₈	1 ⁵ / ₃₂	4	7 ⁷ / ₈	13
2	24 ⁵ / ₁₆	13 ⁷ / ₁₆	9 ³ / ₈	10 ¹ / ₄	10 ⁵ / ₈	11 ¹ / ₈	3 ⁷ / ₁₆	2	3 ⁷ / ₈	1 ³ / ₁₆	4 ¹⁵ / ₁₆	1 ¹ / ₄	13 ⁵ / ₈
3	28 ³ / ₁₆	14 ¹³ / ₁₆	9 ¹ / ₈	10 ¹ / ₂	12 ¹ / ₂	22 ³ / ₈	6	1 ¹ / ₃₂	5 ³ / ₈	1 ³ / ₁₆	6 ¹ / ₂	1	19 ¹ / ₈
5	29 ¹ / ₁₆	14 ¹⁵ / ₁₆	9 ¹ / ₈	10 ¹ / ₂	12 ¹ / ₂	22 ³ / ₈	6	7 ⁷ / ₈	3 ¹ / ₂	1 ⁵ / ₁₆	6 ¹ / ₂	1	19 ¹ / ₈

Specifications

Product code	Rated capacity* (tons)	Lift (ft.)	Speed (F.P.M.)	H.P.	Rope no. & dia.	Net weight (lbs.)
6000G	1	25	18	1	2 1/4	230
6004G	2	20	14	2	2 5/16	280
6008G	3	30	18	4	4 5/16	560
6016G	5	20	10	4	6 5/16	580

Trolley flange range width 1 ton 3" min., 5" max.; 2 ton 3⁵/₈" min., 6" max.; 3-5 ton 4" min., 6¹/₄" max.

* **WARNING**

Overloading and improper use can result in injury.

To avoid injury:

- Do not exceed working load limit, load rating capacity
- Do not use to lift people or loads over people.
- use only alloy chain for overhead lifting.
- Read and follow all instructions.

Polaris hoist with motor driven trolley

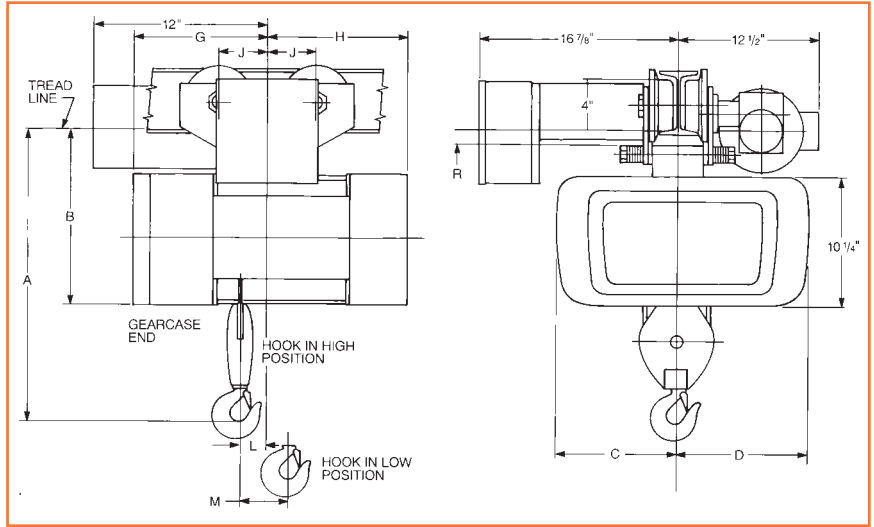

Clearance dimensions (in.)

Rated capacity* (tons)	A	B	C	D	G	H	J	L	M	R
1	22 ¹ / ₁₆	13 ⁹ / ₁₆	9 ³ / ₈	10 ¹ / ₄	10 ⁵ / ₈	11 ¹ / ₈	3 ⁷ / ₈	2	3 ⁷ / ₈	1 ⁵ / ₁₆
2	24 ⁷ / ₁₆	13 ⁹ / ₁₆	9 ³ / ₈	10 ¹ / ₄	10 ⁵ / ₈	11 ¹ / ₈	4 ⁹ / ₁₆	2	3 ⁷ / ₈	1 ⁵ / ₁₆

Specifications

Product code	Rated capacity* (tons)	HOIST				TROLLEY		Net weight (lbs.)
		Lift (ft.)	Speed (F.P.M.)	H.P.	Rope no. & dia.	Speed (F.P.M.)	H.P.	
6000M	1	25	16	1	2 1/4	75	1/4	266
6004M	2	20	16	2	2 5/16	60	1/4	385

Trolley flange range width 1 ton 3" min., 5" max.; 2 ton 3⁵/₈" min., 6" max.

*** ⚠ WARNING**

Overloading and improper use can result in injury.

To avoid injury:

- Do not exceed working load limit, load rating capacity
- Do not use to lift people or loads over people.
- use only alloy chain for overhead lifting.
- Read and follow all instructions.

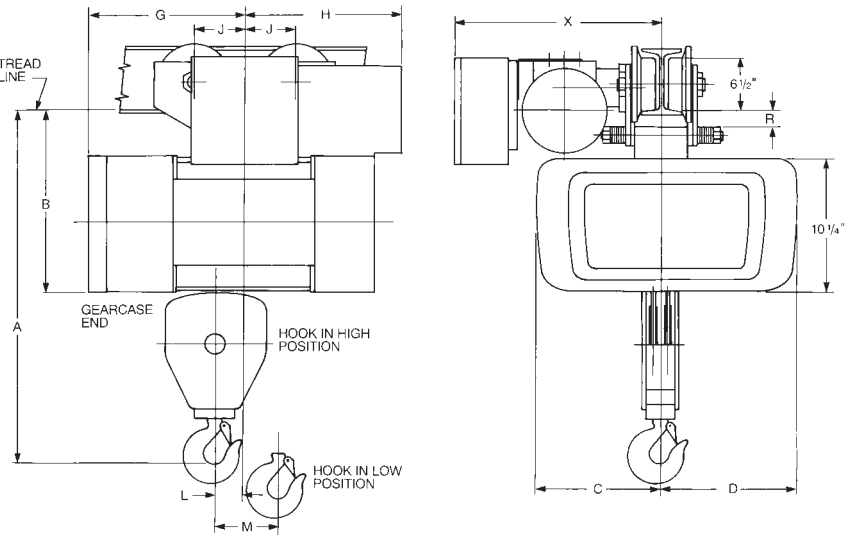

Clearance dimensions (in.)

Rated capacity* (tons)	A	B	C	D	G	H	J	L	M	R
3	27 ³ / ₁₆	14 ⁵ / ₈	9 ¹ / ₈	10 ¹ / ₂	12 ¹ / ₂	22 ³ / ₈	6	1 ¹ / ₃₂	5 ³ / ₈	1 ³ / ₁₆
5	29 ¹ / ₁₆	14 ¹⁵ / ₁₆	9 ¹ / ₈	10 ¹ / ₂	12 ¹ / ₂	22 ³ / ₈	6	7/8	3 ¹ / ₂	1 ⁵ / ₁₆

Specifications

Product code	Rated capacity* (tons)	HOIST				TROLLEY		Net weight (lbs.)
		Lift (ft.)	Speed (F.P.M.)	H.P.	Rope no. & dia.	Speed (F.P.M.)	H.P.	
6008M	3	30	16	4	4 5/16	50	1/2	525
6016M	5	20	12	4	6 5/16	50	1/2	545

Trolley flange range width 4" min., 6¹/₄" max.

Apollo wire rope hoist

The Apollo compact wire rope hoist provides high hook lift with no design compromises. It lets you choose from the widest range of lifts, lifting speeds, clearances, mounting options and controls of any hoist on the market.



- Weston-type mechanical load brake and multiple disc motor brake
- 2-20 ton capacity for wide range of lifting needs
- Low headroom design
- Double reduction reduced gearing provides smooth, quiet drive train
- NEMA 4, 4x/12 enclosed push-button control
- Reverse plugging block operated upper limit switch
- Aluminum gear housing and covers
- Deep grooved, large diameter rope drum eliminates overwrap
- Plain, geared or motor driven trolleys available
- Rugged, low maintenance contactor control
- Hinged control panel cover permits easy access to the control components
- One piece welded steel frame ensures precise fit and long life
- Integrally mounted weldinglug permits various trolley attachment options
- Block operated limit switch
- Bearings supported in an independent gear case spider give a precise fit and allow removal of gear case cover without disassembly of gearing
- One-year warranty
- Tested to 125% of rated load prior to shipment
- Metric rated
- Made in the U.S.A.

* WARNING

Overloading and improper use can result in injury.

To avoid injury:

- Do not exceed working load limit, load rating capacity
- Do not use to lift people or loads over people.
- use only alloy chain for overhead lifting.
- Read and follow all instructions.

Apollo hoist with lug suspension

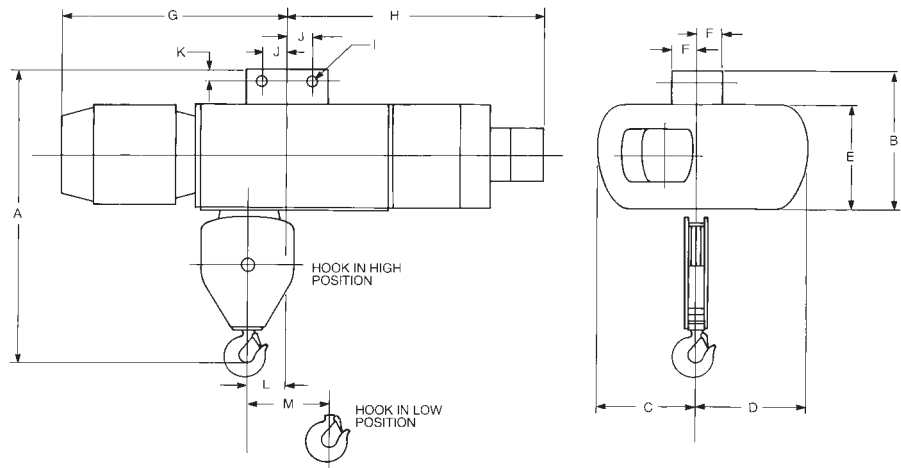

Clearance dimensions (in.)

Rated capacity* (tons)	A	B	C	D	E	F	G	H	I	J	K	L	M
5	36 ⁵ / ₈	16 ¹ / ₂	11 ⁵ / ₈	13 ¹ / ₈	12 ¹ / ₂	3	22 ³ / ₄	30 ¹ / ₄	1 ⁹ / ₃₂	3	1 ¹ / ₈	3 ³ / ₄	4 ⁷ / ₈
7.5	36 ⁷ / ₈	16 ¹ / ₂	11 ⁵ / ₈	13 ³ / ₈	12 ¹ / ₂	3	25 ⁵ / ₈	30 ¹ / ₄	1 ¹⁷ / ₃₂	3	1 ¹ / ₈	3 ¹ / ₄	4 ³ / ₄

Specifications

Product code	Rated capacity* (tons)	Lift (ft.)	Speed (F.P.M.)	H.P.	Rope no. & dia.	Weight (lbs.)
6020L	5	26	15	5	4 ³ / ₈	860
6028L	7.5	22	14	7.5	4 ⁷ / ₁₆	910

* **WARNING**

Overloading and improper use can result in injury.

To avoid injury:

- Do not exceed working load limit, load rating capacity
- Do not use to lift people or loads over people.
- Use only alloy chain for overhead lifting.
- Read and follow all instructions.

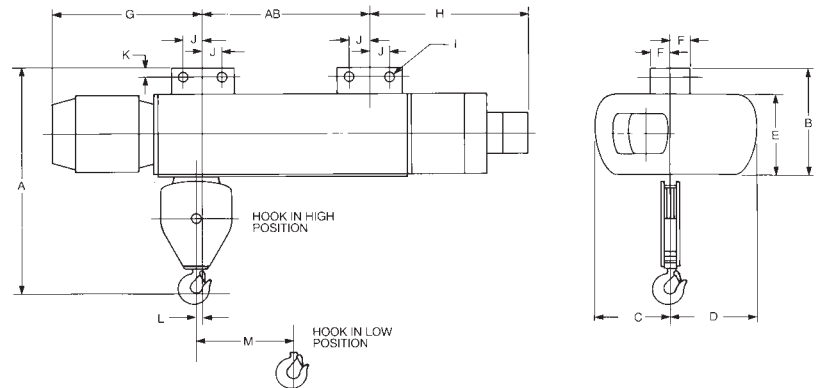

Dual lug

Clearance dimensions (in.)

Rated capacity* (tons)	A	B	C	D	E	F	G	H	I	J	K	L	M	AB
5	36 ⁵ / ₈	16 ¹ / ₂	11 ⁵ / ₈	13 ¹ / ₈	12 ¹ / ₂	3	25 ³ / ₄	24	1 ⁹ / ₃₂	3	1 ³ / ₈	3 ³ / ₈	8 ³ / ₄	25 ³ / ₈
10	39 ⁷ / ₈	19	11 ⁵ / ₈	13 ¹ / ₈	12 ¹ / ₂	3	19 ⁷ / ₈	23 ⁵ / ₈	1 ¹⁷ / ₃₂	3	1 ¹ / ₂	2 ⁵ / ₈	5 ³ / ₄	27 ⁵ / ₈

Specifications

Product code	Rated capacity* (tons)	Lift (ft.)	Speed (F.P.M.)	H.P.	Rope no. & dia.	Weight (lbs.)
6024L	5	47	20	7.5	4 ³ / ₈	1225
6032L	10	25	13.5	10	6 ⁷ / ₁₆	1325

Apollo hoist with plain push trolley

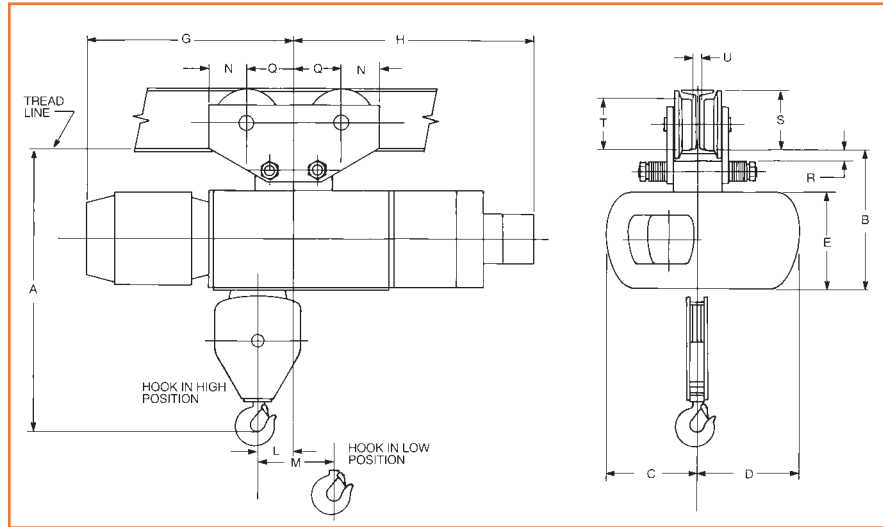

Clearance dimensions (in.)

Rated capacity* (tons)	A	B	C	D	E	G	H	L	M	N	Q	R	S	T	U
5	38	17 ⁷ / ₈	11 ⁵ / ₈	13 ¹ / ₈	12 ¹ / ₂	22 ³ / ₄	30 ¹ / ₄	3 ³ / ₄	4 ⁷ / ₈	4 ⁷ / ₈	6	1 ¹³ / ₃₂	7 ⁹ / ₁₆	6 ¹ / ₂	1
7.5	38	17 ⁷ / ₈	11 ⁵ / ₈	13 ¹ / ₈	12 ¹ / ₂	25 ³ / ₈	30 ¹ / ₄	3 ¹ / ₄	4 ³ / ₄	4 ⁷ / ₈	6	1 ¹³ / ₃₂	7 ⁹ / ₁₆	6 ¹ / ₂	1

Specifications

Product code	Rated capacity* (tons)	Lift (ft.)	Speed (F.P.M.)	H.P.	Rope no. & dia.	Net weight (lbs.)
6020P	5	26	15	5	4 3/8	1000
6028P	7.5	22	14	7.5	4 7/16	1050

Trolley flange size range width 4" min., 6¹/₄" max. standard

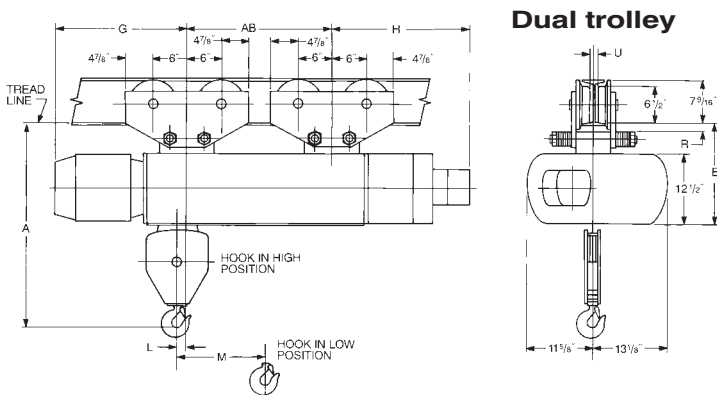

Dual trolley

*** ⚠ WARNING**

Overloading and improper use can result in injury.

To avoid injury:

- Do not exceed working load limit, load rating capacity
- Do not use to lift people or loads over people.
- use only alloy chain for overhead lifting.
- Read and follow all instructions.

Clearance dimensions (in.)

Rated capacity* (tons)	A	B	G	H	L	M	R	U	AB
5	38	17 ⁷ / ₈	22 ⁵ / ₈	24	3/8	8 ³ / ₄	1 ¹³ / ₃₂	1	25 ³ / ₈
10	41 ⁷ / ₈	20 ¹ / ₄	19 ⁷ / ₈	23 ⁵ / ₈	2 ⁵ / ₈	5 ³ / ₄	1 ⁹ / ₃₂	1 ¹¹ / ₁₆	27 ⁵ / ₈

Specifications

Product code	Rated capacity* (tons)	Lift (ft.)	Speed (F.P.M.)	H.P.	Rope no. & dia.	Weight (lbs.)
024P	5	47	20	7.5	4 3/8	1590
032P	10	25	13	10	6 7/16	1690

Trolley flange size range width 4" min., 6¹/₄" max. standard

Apollo hoist with hand geared trolley

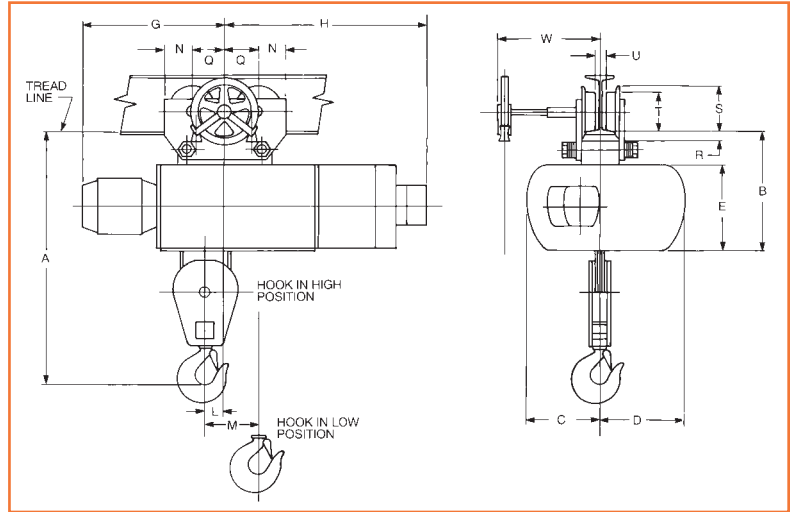
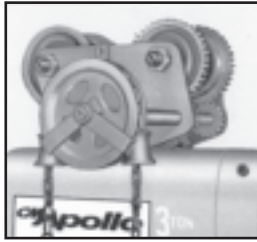

Clearance dimensions (in.)

Rated capacity* (tons)	A	B	C	D	E	G	H	L	M	N	Q	R	S	T	U	W
5	38	17 ⁷ / ₈	11 ⁵ / ₈	13 ¹ / ₈	12 ¹ / ₂	22 ³ / ₄	30 ¹ / ₄	3 ³ / ₄	4 ⁷ / ₈	4 ⁷ / ₈	6	1 ¹³ / ₃₂	7 ⁹ / ₁₆	6 ¹ / ₂	1	19 ¹ / ₈
7.5	38	17 ⁷ / ₈	11 ⁵ / ₈	13 ¹ / ₈	12 ¹ / ₂	25 ⁵ / ₈	30 ¹ / ₄	3 ¹ / ₄	4 ³ / ₄	4 ⁷ / ₈	6	1 ¹³ / ₃₂	7 ⁹ / ₁₆	6 ¹ / ₂	1	19 ¹ / ₈

Specifications

Product code	Rated capacity* (tons)	Lift (ft.)	Speed (F.P.M.)	H.P.	Rope no. & dia.	Net weight (lbs.)
6020G	5	26	15	5	4 3/8	1085
6028G	7.5	22	14	7.5	4 7/16	1135

Trolley flange size range width 4" min., 6¹/₄" max. standard

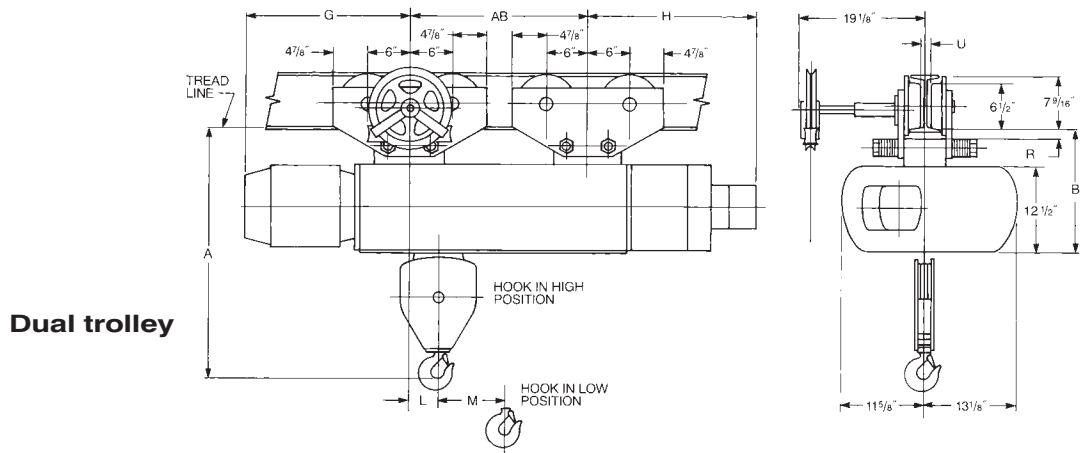

Clearance dimensions (in.)

Rated capacity* (tons)	A	B	G	H	L	M	R	U	AB
5	38	17 ⁷ / ₈	22 ⁵ / ₈	24	3 ³ / ₈	8 ³ / ₄	1 ¹³ / ₃₂	1	25 ³ / ₈
10	41 ⁷ / ₈	20 ¹ / ₄	19 ⁷ / ₈	23 ⁵ / ₈	2 ⁵ / ₈	5 ³ / ₄	1 ⁹ / ₃₂	1 ¹¹ / ₁₆	27 ⁵ / ₈

Specifications

Product code	Rated capacity* (tons)	Lift (ft.)	Speed (F.P.M.)	H.P.	Rope no. & dia.	Weight (lbs.)
6024G	5	47	20	7.5	4 3/8	1650
6032G	10	25	13	10	6 7/16	1750

Trolley flange size range width 4" min., 6¹/₄" max. standard

Apollo hoist with motor driven trolley

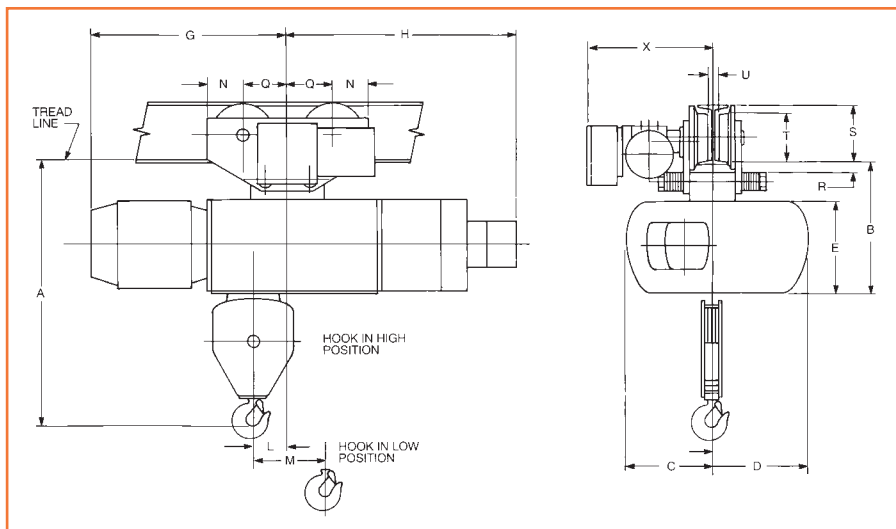
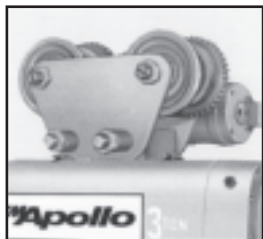

Clearance dimensions (in.)

Rated capacity* (tons)	A	B	C	D	E	G	H	L	M	N	Q	R	S	T	U	X
5	37 ⁷ / ₈	17 ⁷ / ₈	11 ⁵ / ₈	13 ¹ / ₈	12 ¹ / ₂	22 ³ / ₄	30 ¹ / ₄	3 ³ / ₄	4 ⁷ / ₈	4 ⁷ / ₈	6	11 ¹³ / ₃₂	7 ⁹ / ₁₆	6 ¹ / ₂	1	18
7.5	38	17 ⁷ / ₈	11 ⁵ / ₈	13 ¹ / ₈	12 ¹ / ₂	25 ⁵ / ₈	30 ¹ / ₄	3 ¹ / ₄	4 ³ / ₄	4 ⁷ / ₈	6	11 ¹³ / ₃₂	7 ⁹ / ₁₆	6 ¹ / ₂	1	18

Specifications

Product code	Rated capacity* (tons)	HOIST				TROLLEY		Weight (lbs.)
		Lift (ft.)	Speed (F.P.M.)	H.P.	Rope no. & dia.	Speed (F.P.M.)	H.P.	
6020M	5	26	15	5	4 3/8	50	1/2	1050
6028M	7.5	22	14	7.5	4 7/16	50	1/2	1100

Trolley flange size range width 4" min., 6¹/₄" max. standard

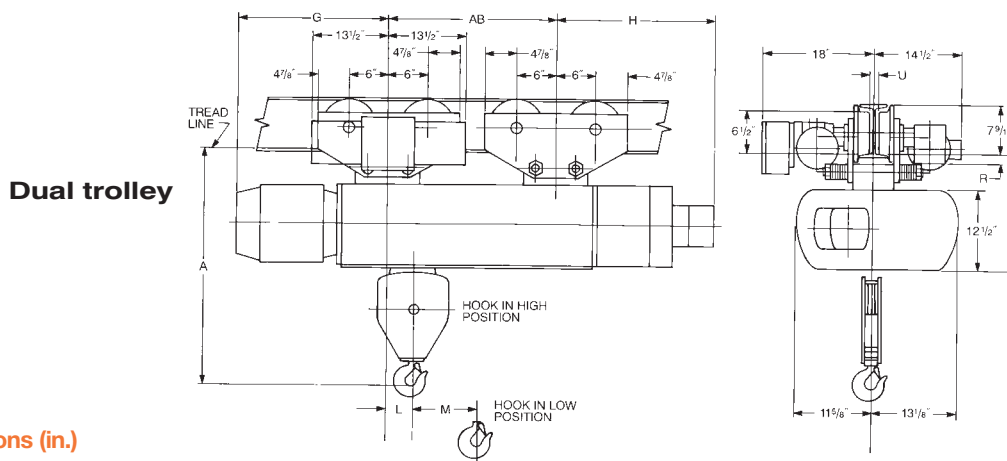

Clearance dimensions (in.)

Rated capacity* (tons)	A	B	G	H	L	M	R	U	AB
5	38	17 ⁷ / ₈	22 ⁵ / ₈	24	3 ³ / ₈	8 ³ / ₄	11 ¹³ / ₃₂	1	25 ³ / ₈
10	41 ⁷ / ₈	20 ¹ / ₄	19 ⁷ / ₈	23 ⁵ / ₈	2 ⁵ / ₈	5 ³ / ₄	1 ⁹ / ₃₂	1 ¹¹ / ₁₆	27 ⁵ / ₈

Specifications

Product code	Rated capacity* (tons)	HOIST				TROLLEY		Net weight (lbs.)
		Lift (ft.)	Speed (F.P.M.)	H.P.	Rope no. & dia.	Speed (F.P.M.)	H.P.	
6024M	5	47	20	7.5	4 3/8	50	(2) 1/4	1685
6032M	10	25	13	10	6 7/16	50	(2) 1/4	1785

Trolley flange size range width 4" min., 6¹/₄" max. standard

Lodestar Air XL Pneumatic Chain Hoist



Columbus McKinnon introduces a new line of Lodestar Air XL chain hoists for lifting applications from 2 to 7¹/₂ tons. The offering provides heavy-duty hoists featuring variable speeds and higher capacities than traditional air chain hoists. Workers in automotive plants, heavy equipment manufacturing, chemical plants, refineries, and related rugged work environments will experience the same dependability and versatility that they have relied on from CM products for many years.

The features of the Lodestar Air XL Chain Hoist includes:

- Lifting capacities up to 7¹/₂ tons
- Variable lifting speeds
- Maximum lifting speed of 31 feet per minute
- Forged ten-pocket oblique-lay liftwheel for smooth chain operation, constant chain speed, and reduced chain wear
- Standard overload protector
- Clutch acts as upper and lower limits
- Six-vane rotary air motor
- Pendant controls provide precise load spotting
- Air actuated motor brake for positive load control
- Factory tested at 125% of rated capacity
- Spark resistant models available
- Lifetime warranty
- Made in U.S.A.
- Standard Lift: 10 ft.
- Air inlet size: 1" NPT
- Air supply hose size: 1" I.D. min.
- Consumption: 175 CFM at 90 PSI
- Exhaust: 1 1/4" NPT

Lodestar Air XL with Hook Suspension-Specifications

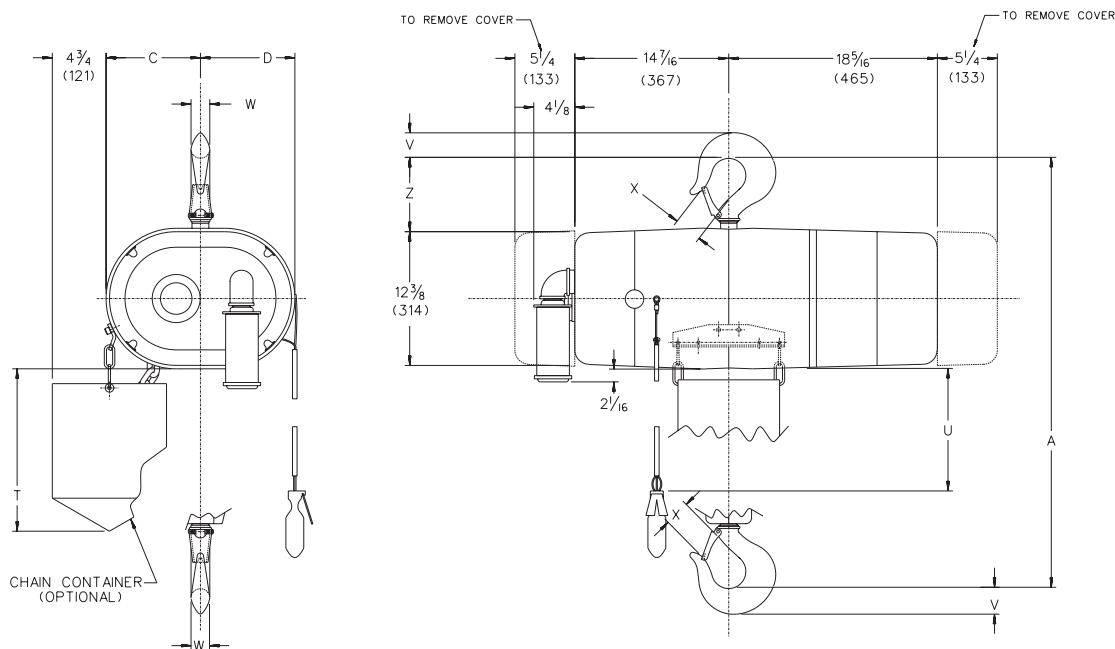

Clearance Dimensions (inches)**

Dimensions	Single Reeved 2 ton capacity	Double Reeved 3-5 ton capacity	Triple Reeved 6 ton capacity
A	25	$35\frac{5}{16}$	$36\frac{3}{16}$
C	$8\frac{7}{16}$	$11\frac{3}{8}$	$11\frac{3}{8}$
D	$8\frac{1}{8}$	$5\frac{1}{2}$	$5\frac{1}{2}$
T (based on 10 ft. lift)	$14\frac{3}{16}$	$14\frac{3}{16}$	$14\frac{3}{16}$
U (based on 10 ft. lift)	6'- 3"	6'- 3"	6'- 3"
V	$1\frac{1}{2}$	$2\frac{1}{4}$	$2\frac{1}{4}$
W	$1\frac{1}{8}$	$1\frac{5}{8}$	$1\frac{5}{8}$
X	$1\frac{5}{16}$	$2\frac{1}{16}$	$2\frac{1}{16}$
Z	$4\frac{1}{8}$	$5\frac{1}{2}$	$5\frac{1}{2}$
Weight (lbs.)	347	421	453
Lifting Speed (FPM)	31	21/13	10

**Dimensions listed are for minimum size "S" beam.

CM® Repair/Replacement Policy

All Hoists are thoroughly inspected and performance tested prior to shipment. If any properly maintained CM Hoist develops a performance problem due to a material or workmanship defect, as verified by Columbus McKinnon, repair or replacement of the hoist will be made to the original purchaser without charge. This repair/replacement policy applies only to Hoists installed, maintained and operated as outlined in the applicable accompanying CM Hoist Manual, and specifically excludes normal wear, abuse, improper installation, improper or inadequate maintenance, hostile environmental effects, and unauthorized repairs/modifications.

ANSI/OSHA

CM hoists are manufactured in accordance with our interpretation of the ASME/ANSI Code B30.16 for Overhead Hoists and U.S. Occupational Safety and Health Act regulations at the time of manufacture. Users should check each installation for compliance with the application, operation and maintenance requirements of these regulations and standards.

Lodestar Air XL with plain trolley and geared trolley-Specifications

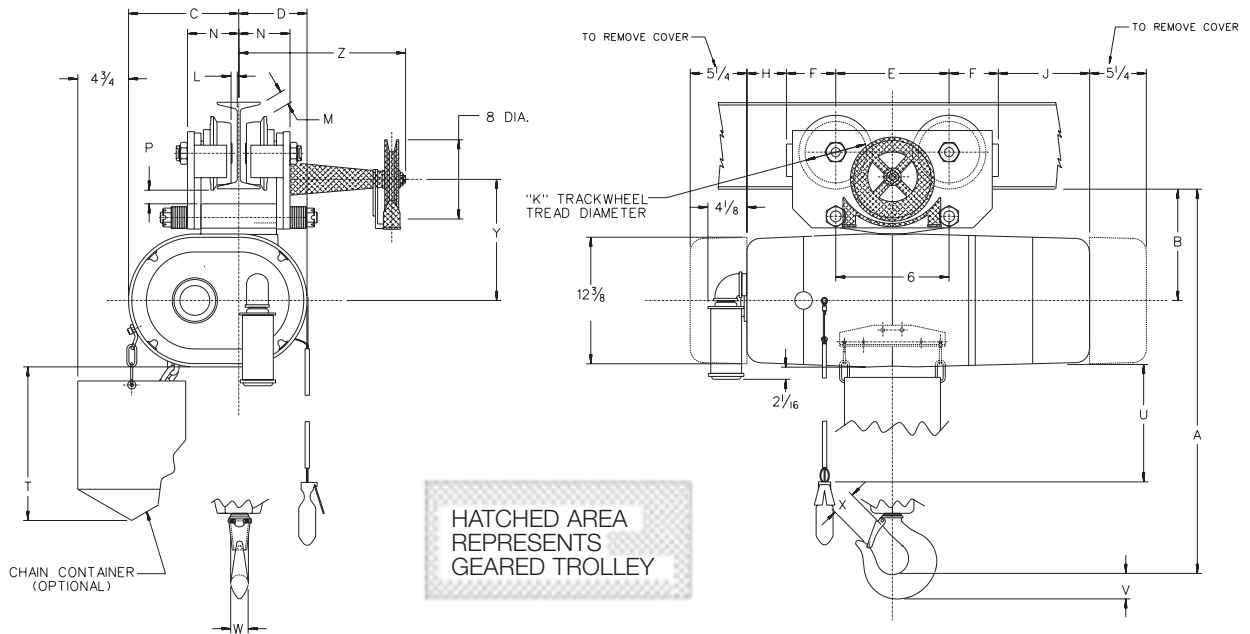

Clearance Dimensions (inches)**

Dimensions	Single Reeved	Double Reeved		Triple Reeved
	2 ton capacity	3 ton capacity	5 ton capacity	6 & 7½ ton capacity
A	28 ¹¹ / ₁₆	33½	33 ³ / ₄	34 ⁵ / ₈
B	9 ³ / ₄	10 ⁷ / ₁₆	10 ¹¹ / ₁₆	10 ¹ / ₁₆
C	8 ⁷ / ₁₆	11 ³ / ₈	11 ³ / ₈	11 ³ / ₈
D	8 ³ / ₈	5½	5½	5½
E	9½	9 ¹ / ₈	12	12
F	3½	3¼	4 ¹³ / ₁₆	4 ¹³ / ₁₆
H	5¼	5 ¹¹ / ₁₆	2 ¹¹ / ₁₆	2 ¹¹ / ₁₆
J	10 ¹ / ₁₆	10½	7½	7½
K	4 ¹ / ₁₆	4	6½	6½
L	½	5 ⁵ / ₈	5 ⁵ / ₈	5 ⁵ / ₈
M	½	2 ¹¹ / ₁₆	0	0
N	5	3 ⁵ / ₈	3 ⁷ / ₈	3 ⁷ / ₈
P	1¼	3 ³ / ₈	7 ¹ / ₁₆	7 ¹ / ₁₆
T (based on 10 ft. lift)	14 ³ / ₁₆	14 ³ / ₁₆	14 ³ / ₁₆	14 ³ / ₁₆
U (based on 10 ft. lift)	6'- 3"	6'- 3"	6'- 3"	6'- 3"
V	1½	2¼	2¼	2¼
W	1 ¹ / ₈	1 ⁵ / ₈	1 ⁵ / ₈	1 ⁵ / ₈
X	1 ⁵ / ₁₆	2 ¹ / ₁₆	2 ¹ / ₁₆	2 ¹ / ₁₆
Y*	11 ⁵ / ₁₆	12 ⁷ / ₈	11 ¹ / ₈	11 ¹ / ₈
Z*	—	19 ¹ / ₈	19 ¹ / ₈	19 ¹ / ₈
Weight (lbs.)-Plain Trolley	407	476	576	608
Weight (lbs.)-Geared Trolley	452	491	586	618
Minimum Radius Curve (ft.)	4	4	6	6
Standard Beam Flange Adj. Range (in.)	3.33-5.55	4.00-6.25	4.00-6.25	4.00-6.25
Lifting Speed (FPM)	31	21	13	10/9

*Geared Trolley Dimensions Only

**Dimensions listed are for minimum size "S" beam.

Lodestar Air XL with Motor Driven Trolley-Specifications

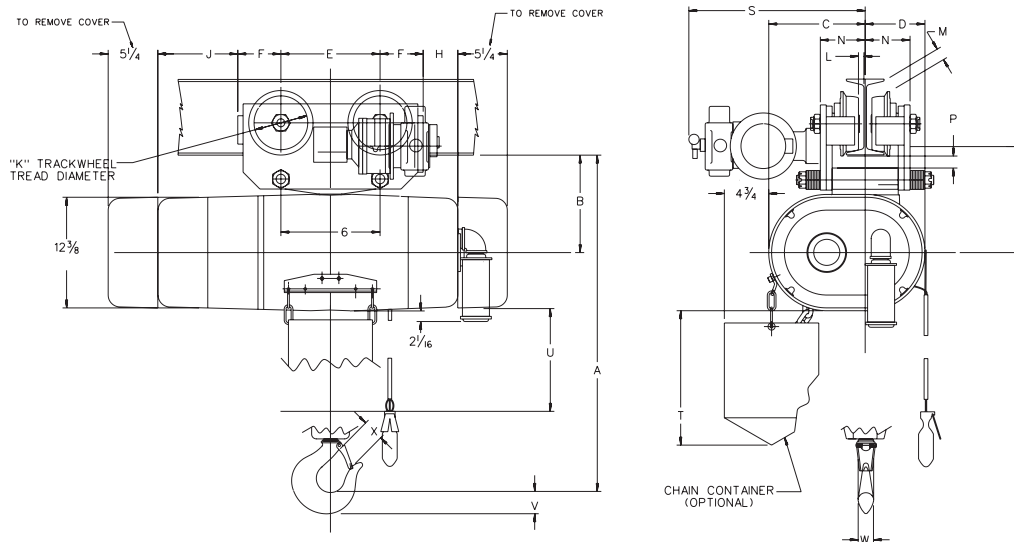

Clearance Dimensions (inches)**

Dimensions	Double Reeved		Triple Reeved	
	2 ton capacity	3 ton capacity	5 ton capacity	6 & 7 1/2 ton capacity
A	33 1/2	33 1/2	33 3/4	34 5/8
B	10 7/16	10 7/16	10 11/16	10 11/16
C	9 5/16	11 3/8	11 3/8	11 3/8
D	7 9/16	5 1/2	5 1/2	5 1/2
E	9 1/8	9 1/8	12	12
F	3 1/4	3 1/4	4 13/16	4 13/16
H	5 11/16	5 11/16	2 11/16	2 11/16
J	10 1/2	10 1/2	7 1/2	7 1/2
K	4	4	6 1/2	6 1/2
L	5/8	5/8	5/8	5/8
M	2 11/16	2 11/16	0	0
N	3 5/8	3 5/8	3 7/8	3 7/8
P	3/8	3/8	7/16	7/16
S	15 15/16	15 15/16	17 3/4	17 3/4
T (based on 10 ft. lift)	14 3/16	14 3/16	14 3/16	14 3/16
U (based on 10 ft. lift)	6'- 3"	6'- 3"	6'- 3"	6'- 3"
V	2 1/4	2 1/4	2 1/4	2 1/4
W	1 5/8	1 5/8	1 5/8	1 5/8
X	2 1/16	2 1/16	2 1/16	2 1/16
Minimum Radius Curve (ft.)	4	4	6	6
Weight (lbs.)	505	569	611	643
Standard Beam Flange Adj. Range (in.)	4.00-6.25	4.00-6.25	4.00-6.25	4.00-6.25
Trolley Speed (ft./min) Standard Single Speed	50	50	50	50
Lifting Speeds	31	21	13	10/9

**Dimensions listed are for minimum size "S" beam.

WARNING

Failure to properly install, operate and maintain the Lodestar Air XL Hoist may result in injury and/or property damage.

TO AVOID INJURY:

- Installation, maintenance and operation must be carried out as instructed in the manual provided with the Lodestar Air XL Hoist.
- Do not use the Lodestar Air XL Hoist for lifting people; special equipment is required for this purpose. Refer to ASME/ANSI A-17 Series and applicable state and local codes for specific requirements.

ShopAir™ chain hoist

Compact, powerful, and precise for assembly and manufacturing applications up to 1,000 pounds.

The CM ShopAir combines superior lifting speeds, rugged design, and precise load spotting in a portable air chain hoist. As a workstation hoist or a production line hoist, the ShopAir is the ideal choice.

CAPACITIES: 250 to 1,000 Lbs.

NORMAL OPERATING PRESSURE: 90 PSI (6.2 bar)

AIR CONSUMPTION: 34 cu.feet/min.

- Standard Protector™ overload device.
- 10-pocket, oblique lay liftwheel provides longer chain life.
- Epoxy powder coat finish provides a durable exterior.
- Durable reduction gearing means reliable operation
- Variable flow, two lever pendant for precise load spotting.
- Threaded external exhaust for piping away exhaust in clean room or painting applications.
- Small, compact design for commercial & industrial applications.
- Industrial duty air motor for tough applications.
- Gear train is lifetime - lubricated with non-oxidizing grease.
- Hardened forged steel, latch -type lower hook rotates 360°.
- Hardened forged steel, rigid latch -type upper hook.
- Rugged cast aluminum alloy hoist frame.
- Alloy load chain.
- Maximum pendant drop - 36 ft.
- Lifetime warranty against defects in materials and workmanship.
- Made in U.S.A.



300 Lb. model shown with optional chain container

ShopAir™ chain hoist-Specifications

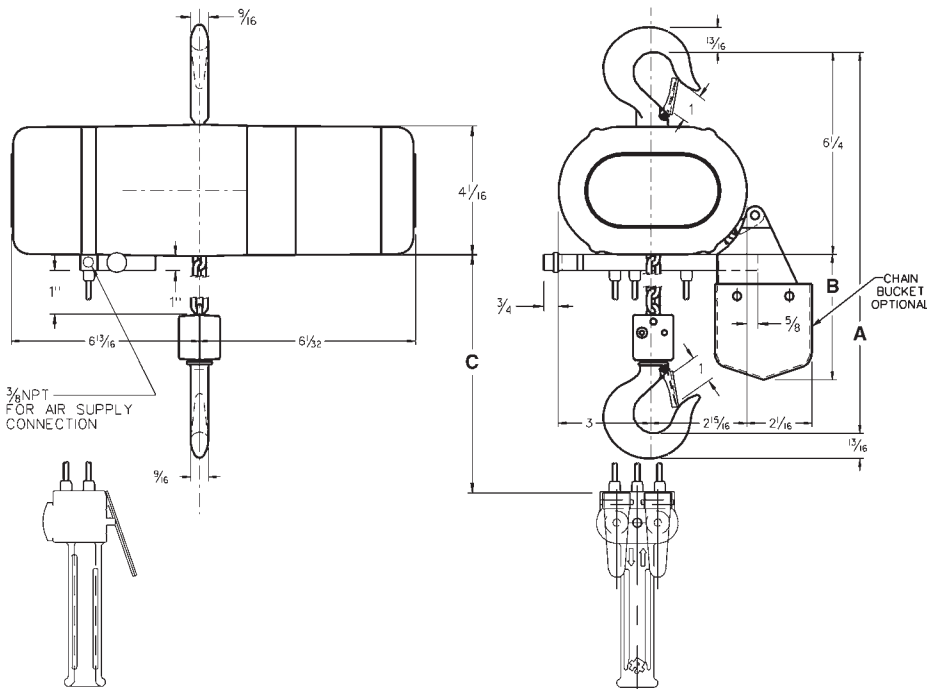

Specifications

Product code	Cap. (lbs.)	(in.)			Number of load chains	Speed FPM (under full load)		Shipping weight (lbs.)
		A	B	*C		lifting	lowering	
2178	250	10 ⁷ / ₈	3 ⁷ / ₈	6' 4"	1	31	83	30
2180	300	10 ⁷ / ₈	3 ⁷ / ₈	6' 4"	1	31	83	30
2182	500	10 ⁷ / ₈	3 ⁷ / ₈	6' 4"	1	21	75	30
2179	500	11 ¹⁵ / ₁₆	5 ³ / ₄	6' 4"	2	16	42	34
2181	600	11 ¹⁵ / ₁₆	5 ³ / ₄	6' 4"	2	16	42	34
2183	1,000	11 ¹⁵ / ₁₆	5 ³ / ₄	6' 4"	2	11	38	34

* ⚠ WARNING

Overloading and improper use can result in injury.

To avoid injury:

- Do not exceed working load limit, load rating capacity
- Do not use to lift people or loads over people.
- use only alloy chain for overhead lifting.
- Read and follow all instructions.

AirStar chain hoist

Designed for general commercial applications where variable speed pneumatic power is preferable. Rated for 1/4, 1/2 and 1 ton capacities, this compact, lightweight hoist features:

- Hoist alloy load chain for heavy duty or stainless steel chain for spark resistant, medium duty loads
- Positive action, heavy-duty shoe type brake that holds the load
- Multi-vane rotary air motor for high torque, smooth operation
- Accurately machined heat treated alloy steel spur gears
- Spark resistant models available for hazardous environments
- Pull cord or pendant throttle control available
- Pull cord control hoists provide a lightweight, economical hoist for accurate control of loads
- Optional pendant throttle control hoists offer ergonomic, one-hand control for ease of operation
- Hook or lug suspension available
- Inlet air swivel with built-in strainer provides free hoist movement
- Aluminum frame and end cover contributes to the lightweight, easily portable, and rugged design
- External brake adjustment
- Limit stops prevent over-travel in upper and lowering directions
- Equa-torque gearing of alloy steel, heat treated spur gears are accurately machined to provide a close meshed, compact gear reduction
- Tapped exhaust port 1/2 NPTF... for cleanroom applications or to add a supplemental muffler in addition to the built-in muffler for even quieter operation
- Lifetime warranty
- Metric rated
- Made in U.S.A.



Basic Hoist Data

Rated Loads: 1/4, 1/2 and 1 Ton
(Spark resistant models are rated at 3/8 and 3/4 ton)

Air Pressure

Recommended: 90 PSI

Air Consumption: 48 SCFM at 90 PSI

Net Wt. (Basic Hoist): 36 lbs.

Suspension: Hook or lug

Control: Pull Cord or Pendant Throttle

Air Inlet: 3/8 NPTF

Air Supply Hose: 1/2 I.D. min.

Air Exhaust: 1/2 NPTF

Lift: 10 foot lifts are standard. Longer lifts are an optional extra.

Pendant

Control: 6 foot length is standard.

Longer lengths are an optional extra.

Optional: For greater corrosion resistance, a plated load chain is offered as an optional extra.



AirStar with hook suspension-Specifications

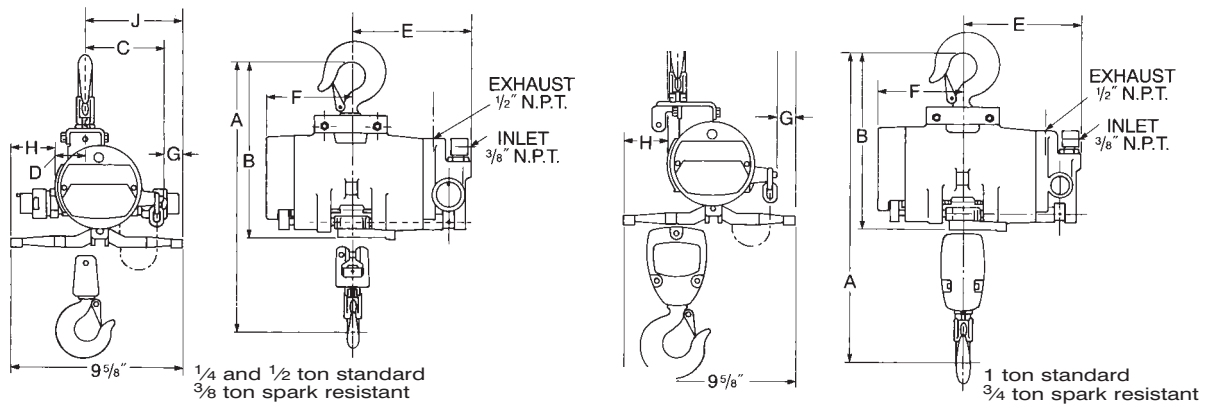

Clearance dimensions (in.)

Rated capacity* (tons)	Product code	A	B	C	D	E	F	G	H	J
1/4	7400A	15 1/4	10 1/4	4 3/4	1 3/4	7 1/16	5 1/16	15/16	2 3/16	5 11/16
1/4	7400B	15 1/4	10 1/4	4 3/4	1 3/4	7 1/16	5 1/16	15/16	2 3/16	5 11/16
1/4	7400C	15 1/4	10 1/4	4 3/4	1 3/4	7 1/16	5 1/16	15/16	2 3/16	5 11/16
1/4	7400D	15 1/4	10 1/4	4 3/4	1 3/4	7 1/16	5 1/16	15/16	2 3/16	5 11/16
1/2	7401A	15 1/4	10 1/4	4 3/4	1 3/4	7 1/16	5 1/16	15/16	2 3/16	5 11/16
1/2	7401B	15 1/4	10 1/4	4 3/4	1 3/4	7 1/16	5 1/16	15/16	2 3/16	5 11/16
1/2	7401C	15 1/4	10 1/4	4 3/4	1 3/4	7 1/16	5 1/16	15/16	2 3/16	5 11/16
1/2	7401D	15 1/4	10 1/4	4 3/4	1 3/4	7 1/16	5 1/16	15/16	2 3/16	5 11/16
3/8	7403A	15 1/4	10 1/4	4 3/4	1 3/4	7 1/16	5 1/16	15/16	2 3/16	5 11/16
3/8	7403B	15 1/4	10 1/4	4 3/4	1 3/4	7 1/16	5 1/16	15/16	2 3/16	5 11/16
1	7402A	18	10 1/4	5 3/4	3/4	7 1/16	5 1/16	15/16	2 3/16	6 11/16
1	7402B	18	10 1/4	5 3/4	3/4	7 1/16	5 1/16	15/16	2 3/16	6 11/16
1	7402C	18	10 1/4	5 3/4	3/4	7 1/16	5 1/16	15/16	2 3/16	6 11/16
1	7402D	18	10 1/4	5 3/4	3/4	7 1/16	5 1/16	15/16	2 3/16	6 11/16
3/4	7404A	18	10 1/4	5 3/4	3/4	7 1/16	5 1/16	15/16	2 3/16	6 11/16
3/4	7404B	18	10 1/4	5 3/4	3/4	7 1/16	5 1/16	15/16	2 3/16	6 11/16

Specifications

Type	Rated capacity* (tons)	Pull cord control		Pendant throttle control**		Reeving	Lifting speed max.† (F.P.M.)	Lowering speed max.† (F.P.M.)
		Product code no.	Net wt. (lbs.)	Product code no.	Net wt. (lbs.)			
Standard models								
Roller chain	1/4	7400A	37	7400B	47	1	65	95
	1/2	7401A	37	7401B	47	1	45	120
	1	7402A	51	7402B	61	2	23	60
Link chain	1/4	7400C	36	7400D	46	1	65	95
	1/2	7401C	36	7401D	46	1	45	120
	1	7402C	49	7402D	59	2	23	60
Spark resistant models								
Link chain	3/8	7403A	36	7403B	46	1	60	100
	3/4	7404A	49	7404B	59	2	29	52

**Equipped with 6 ft. pendant control.

† Speeds based on 90 PSI line pressure and with full rated hoist load.

Hoist speeds are adjustable and can be reduced to 50% of full rated speed. Shipped from factory with hoisting speed set at maximum rated speed; lowering speed set at reduced speed.

Standard lift 10 feet. Longer lifts available.

AirStar with lug suspension-Specifications

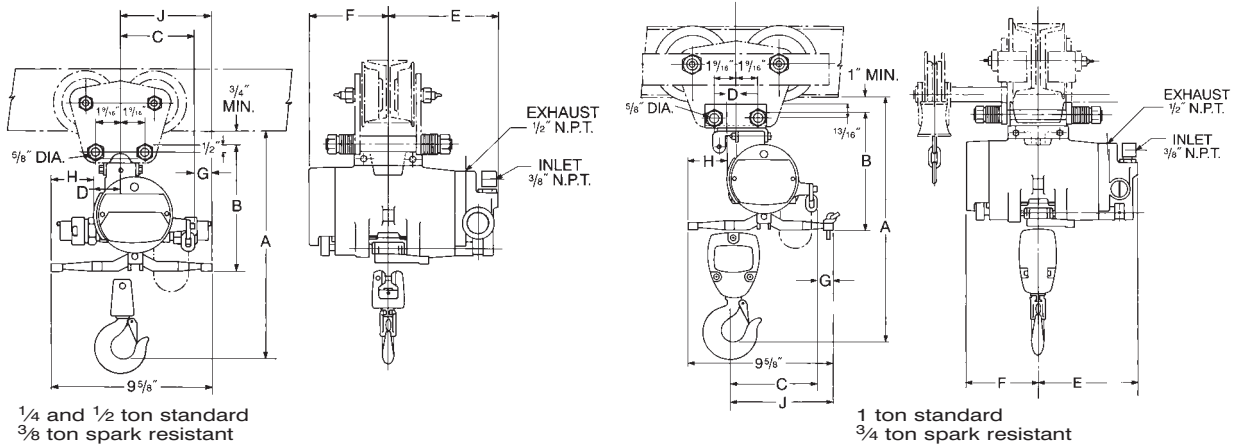

Clearance dimensions (in.)

Rated capacity* (tons)	Product code	A	B	C	D	E	F	G	H	J
1/4	7400F	13 7/8	8 1/8	4 3/4	1 3/4	7 1/16	5 1/16	15/16	2 3/16	5 11/16
1/4	7400G	13 7/8	8 1/8	4 3/4	1 3/4	7 1/16	5 1/16	15/16	2 3/16	5 11/16
1/2	7401F	13 7/8	8 1/8	4 3/4	1 3/4	7 1/16	5 1/16	15/16	2 3/16	5 11/16
1/2	7401G	13 7/8	8 1/8	4 3/4	1 3/4	7 1/16	5 1/16	15/16	2 3/16	5 11/16
3/8	7403C	13 7/8	8 1/8	4 3/4	1 3/4	7 1/16	5 1/16	15/16	2 3/16	5 11/16
3/8	7403D	13 7/8	8 1/8	4 3/4	1 3/4	7 1/16	5 1/16	15/16	2 3/16	5 11/16
1	7402F	17	8 1/4	5 3/4	3/4	7 1/16	5 1/16	15/16	2 3/16	6 11/16
1	7402G	17	8 1/4	5 3/4	3/4	7 1/16	5 1/16	15/16	2 3/16	6 11/16
3/4	7404C	17	8 1/4	5 3/4	3/4	7 1/16	5 1/16	15/16	2 3/16	6 11/16
3/4	7404D	17	8 1/4	5 3/4	3/4	7 1/16	5 1/16	15/16	2 3/16	6 11/16

Specifications

Type	Rated capacity* (tons)	Pull cord control		Pendant throttle control**		Reeving	Lifting speed max.† (F.P.M.)	Lowering speed max.† (F.P.M.)
		Product code no.	Net wt. (lbs.)	Product code no.	Net wt. (lbs.)			
Standard models								
Link chain	1/4	7400F	36	7400G	46	1	65	95
	1/2	7401F	36	7401G	46	1	45	120
	1	7402F	49	7402G	59	2	23	60
Spark resistant models								
Link chain	3/8	7403C	36	7403D	46	1	60	100
	3/4	7404C	49	7404D	59	2	29	52

**Equipped with 6 ft. pendant control.

† Speeds based on 90 PSI line pressure and with full rated hoist load.

Hoist speeds are adjustable and can be reduced to 50% of full rated speed. Shipped from factory with hoisting speed set at maximum rated speed; lowering speed set at reduced speed.

Standard lift 10 feet. Longer lifts available.

Spark Resistant Models

Spark resistant models offer maximum protection in hazardous environments. Components for spark resistance include bronze alloy hooks, stainless steel hook latches, non-magnetic chrome-nickel stainless steel load chain, modified load sprocket, guide and stripper arrangement and lower blocks of stainless steel for the 3/8-ton single line model and anodized aluminum body on the 3/4-ton two part reeved model.

The spark resistant models have capacities derated. The stainless steel load chain is lower strength and not as hard as the standard alloy steel load chain, thereby requiring reduced capacity ratings on these models.

Warning: The equipment illustrated here is not designed or suitable as a power source for lifting or lowering persons. Exceeding rated capacity is dangerous and can result in injury to persons and damage property.

AirStar 6 air hoist

Designed for general industrial applications where variable speed pneumatic power is preferable. Rated for loads of up to 3 tons. This compact, lightweight hoist features:

- Hoist alloy load chain for heavy duty or stainless steel chain for spark resistant, medium duty loads
- Lightweight aluminum frame and cover
- Positive action, spring biased Weston-type load brake holds the load, provides exacting load spotting and control
- Multi-vane rotary air motor with eight vanes for high torque, smooth operation, positive starting
- Precision cut heat treated helical and spur gear combination for quiet, efficient operation
- Pendant throttle handle is full flow design for precision throttle capabilities
- Spark resistant models available for hazardous environments
- Hook or lug suspension available
- Standard overload protector device
- Internal Muffler—reduces sound level
- Throttle Valve—precision throttle valves meter the air for smooth operation
- Chain container optional
- Lifetime warranty
- Metric rated
- Made in U.S.A.



Basic Hoist Data

Rated Loads: 1, 2, and 3-ton (Spark resistant models are rated at 1/2, 1 and 2 ton)

Air Pressure

Recommended: 90 PSI

Air Consumption: 70 SCFM (full load-full speed) slow speed model 80 SCFM (full load-full speed) fast speed model

Pendant Control Hose: 6 foot pendant hose standard for 10 foot lift hoist, longer hose assemblies up to 36 foot available.

Lift: 10 foot lifts are standard. Longer lifts are an optional extra.

Net Wt. (Basic Hoist): 100 pounds

Suspension: Hook or lug

Air Inlet Size: 3/4 NPTF

Air Supply Hose Size: 3/4 I.D. min.

AirStar 6 with hook suspension-Specifications

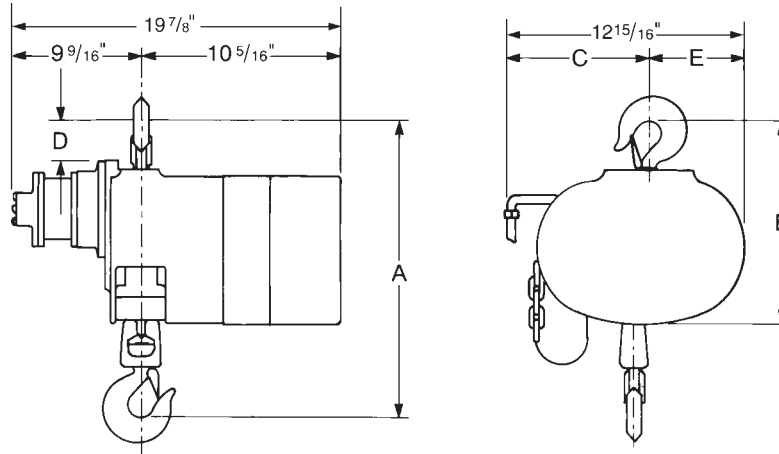

Clearance dimensions (in.)

Rated capacity* (tons)	Product code	A	B	C	D	E
1/2	7408A	16 3/4	11 1/16	6 3/4	2 11/16	6 3/16
1	7405A	16 3/4	11 1/16	6 3/4	2 11/16	6 3/16
1	7405B	16 3/4	11 1/16	6 3/4	2 11/16	6 3/16
1	7409A	22 7/8	12 13/16	8 1/16	4 7/16	4 7/8
2	7406A	22 7/8	12 13/16	8 1/16	4 7/16	4 7/8
2	7406B	22 7/8	12 13/16	8 1/16	4 7/16	4 7/8
2	7410A	25 7/8	14 3/8	5 13/16	5 5/8	7 1/8
3	7407A	25 7/8	14 3/8	5 13/16	5 5/8	7 1/8
3	7407B	25 7/8	14 3/8	5 13/16	5 5/8	7 1/8

Specifications

Model	Rated capacity* (tons)	Product code	Reeving	Full load hoist speed** (F.P.M.)	Full load lowering speed** (F.P.M.)	Approximate net weight (lbs.)
Standard model	1	7405A	1	13	18	93
	1	7405B	1	30	42	95
	2	7406A	2	6	9	110
	2	7406B	2	15	21	112
	3	7407A	3	4	6	144
	3	7407B	3	10	14	146
Spark resistant model	1/2	7408A	1	16	22	95
	1	7409A	2	8	11	112
	2	7410A	3	5	7	146

**Hoist speeds based on 90 PSI line pressure with full load at full throttle.



AirStar 6 with lug suspension

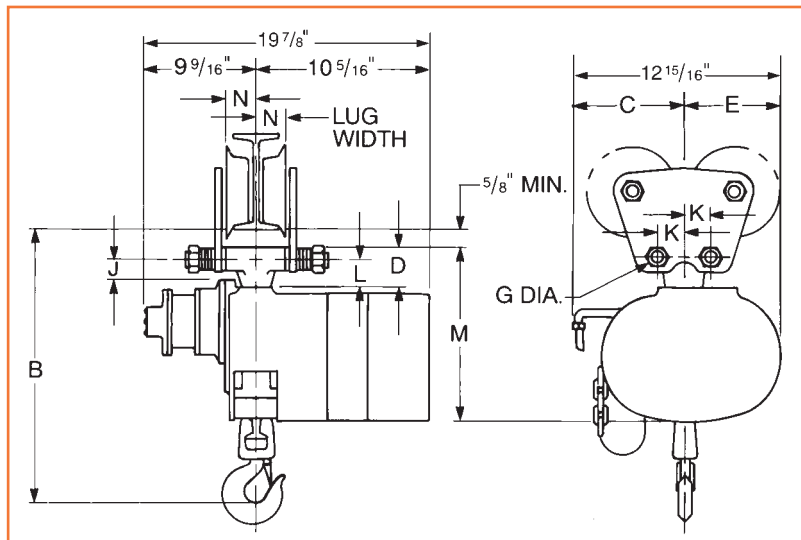

Clearance dimensions (in.)

Rated capacity* (tons)	Product code	B	C	D	E	J	K	L	M	N	G
1/2	7408B	16 1/4	6 3/4	2	6 3/16	7/8	1 9/16	1 5/16	9 15/16	1 13/16	5/8
1	7405C	16 1/16	6 3/4	2	6 3/16	7/8	1 9/16	1 5/16	9 15/16	1 13/16	5/8
1	7405D	16 1/16	6 3/4	2	6 3/16	7/8	1 9/16	1 5/16	9 15/16	1 13/16	5/8
1	7409B	21 3/8	8 1/16	2 13/16	4 7/8	1 1/2	2 1/2	1 15/16	10 11/16	2 3/16	1
2	7406C	19 3/4	8 1/16	2 13/16	4 7/8	1 1/2	2 1/2	1 15/16	10 11/16	2 3/16	1
2	7406D	19 3/4	8 1/16	2 13/16	4 7/8	1 1/2	2 1/2	1 15/16	10 11/16	2 3/16	1
2	7410B	25	5 13/16	4 5/8	7 1/8	2 15/16	3	3 3/8	12 7/8	3	1 1/4
3	7407C	23 3/4	5 13/16	4 5/8	7 1/8	2 15/16	3	3 3/8	12 7/8	3	1 1/4
3	7407D	23 3/4	5 13/16	4 5/8	7 1/8	2 15/16	3	3 3/8	12 7/8	3	1 1/4

Specifications

Model	Rated capacity* (tons)	Product code	Reeving	Full load hoist speed** (F.P.M.)	Full load lowering speed** (F.P.M.)	Approx. net weight (lbs.)
Standard model	1	7405C	1	13	18	106
	1	7405D	1	30	42	108
	2	7406C	2	6	9	116
	2	7406D	2	15	21	118
	3	7407C	3	4	6	164
	3	7407D	3	10	14	166
Spark resistant model	1/2	7408B	1	16	22	110
	1	7409B	2	8	11	120
	2	7410B	3	5	7	170

**Hoist speeds based on 90 PSI line pressure with full load at full throttle.

Max air balancer

CM offers precise positioning or repetitive trans-ferring of loads as heavy as 600 pounds. With up to 8" of float, the operator can position the load easily and precisely by hand.

- Limitless start/stop cycles for reliable performance and productivity
- Exclusive lost load protection system
- Extra safety with exclusive lock out-tag out device that makes the balancer inoperable in the event of damage or required maintenance
- Unique pressure compensated flow control maintains lifting speed regardless of fluctuations in plant air pressure
- Chain lift eliminates spinning or fraying plus delivers long wear life
- 18 pocket liftwheel for smooth balancer operation
- True vertical chain travel (80" max.)
- Ergonomic pendant control station
- Forged steel latch type lower hook with bearing for free rotation
- Supplied complete with chain container for loose end chain
- Optional Series 0980 low headroom trolley to operate 2⁵/₈" through 5⁵/₈" flange beams
- Optional Latchlok hook
- Optional balance control for full 8 feet float capabilities
- Operates on 90 P.S.I. plant air, not 100 P.S.I. like comparable units
- Standard pendant drop 9'-6"
- Made in U.S.A.

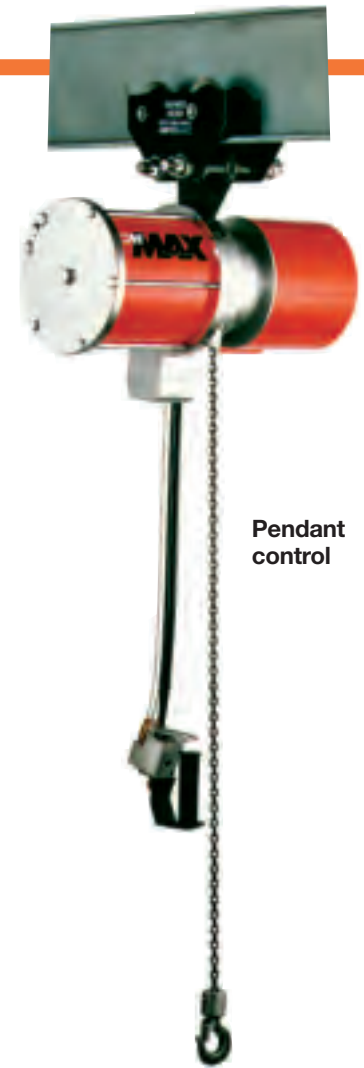

CM Max balancer specifications

Product code	Rated capacity* (lbs.)	Control options	Working range (in.)**	Reach (in.)†	Net weight (lbs.)††
0950	120	Pendant control	80	144	60
0953	120	Balance control	80	144	60
0951	200	Pendant control	80	144	68
0954	200	Balance control	80	144	68
0952	300	Pendant control	80	144	86
0955	300	Balance control	80	144	86
0943	500	Pendant control	80	144	98
0947	120	Dual balance	80	144	60
0948	200	Dual balance	80	144	68
0949	300	Dual balance	80	144	86
0944	120	Pendant control	130	144	60
0945	200	Pendant control	130	144	68
0946	300	Pendant control	130	144	86

** Working range: Vertical lift from the hook in the lowest position to the hook in the highest position.

† Reach: Vertical distance from the bottom of the balancer to the hook in the lowest position. Actual reach may be adjusted at installation and under no circumstances should it be less than 84 inches.

†† Weights listed are for units with pendant controls and do not include the low headroom trolley or suspension plate. For units with balance control, reduce the listed weights by 4 lbs.

Max air balancer-Specifications

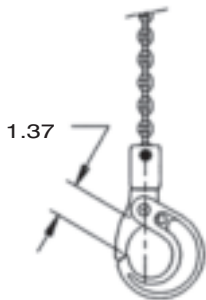
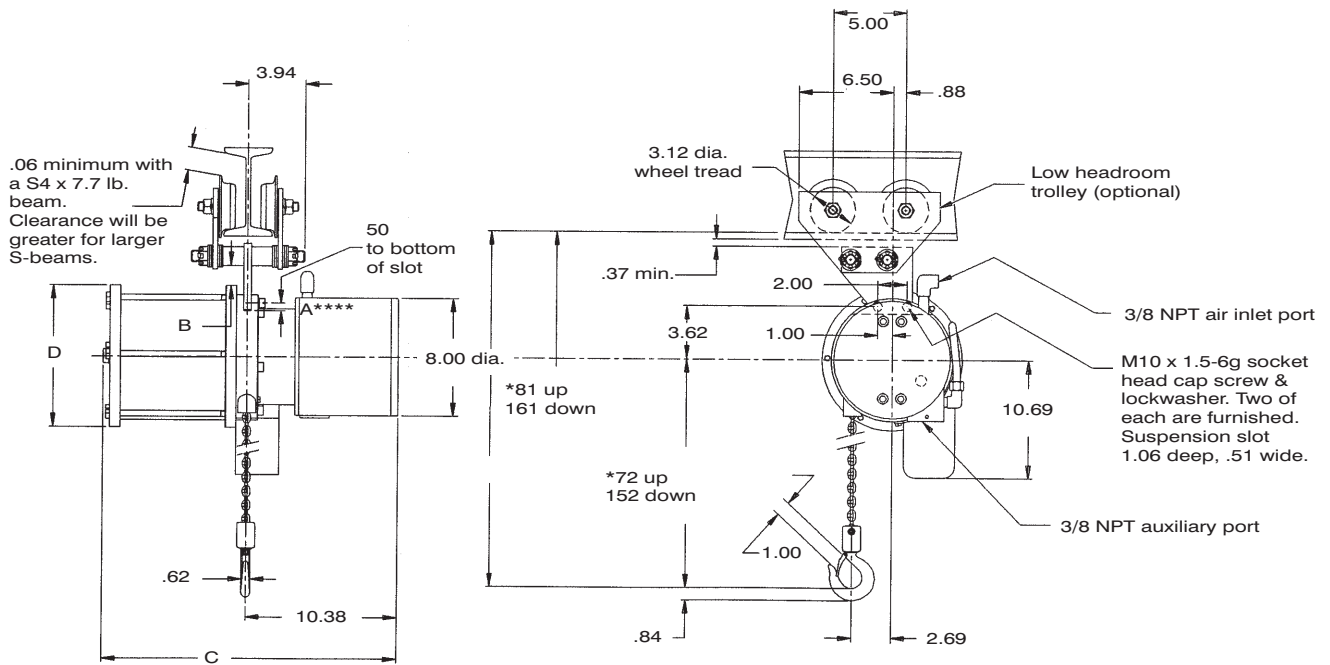

Latchlok hook (optional)

Max clearance dimensions (in.)

Rated capacity** (lbs.)	A**** headroom (in.)	B (in.)	C (in.)	D diameter (in.)
120	18.85	2.00	20.33	7.75
200	18.85	1.38	20.33	9.63
300	18.85	.38	20.45	11.63
500	18.85	.38	31.00	11.63
120 extended lift***	18.85	2.00	26.70	7.75
200 extended lift***	18.85	1.38	26.70	9.63
300 extended lift***	18.85	.38	27.70	11.63

Note: Dimensions are in inches. Double reeved units available in all models except 500 lb. Double reeving does not change down dimension as supplied; it doubles the capacity of the unit, and decreases vertical travel by half.

* Nominal dimension based on the standard length of chain supplied with the CM Max. The chain may be shortened by the customer.

** 90 psi air input is required to operate at the rated capacity.

*** Extended lift provides 130" of lift.

**** Headroom with chain shortened to minimum allowed in up position and with optional low headroom trolley as shown. Headroom will be 2.5" longer with optional double reeve. To get the down dimension add 80" to the up dimension for the standard max and 130" for the extended lift (add half of this dimension for double reeved). Headroom may vary depending on mounting bracket and truck used.

* **WARNING**

Overloading and improper use can result in injury.

To avoid injury:

- Do not exceed working load limit, load rating capacity
- Do not use to lift people or loads over people.
- use only alloy chain for overhead lifting.
- Read and follow all instructions.

Max air balancer accessories

Optional suspension and accessories specifications

Product code	Description	Rated capacity (lbs.)
0957	Single hook suspension	120 & 200
0958	Double hook suspension	300 & 500
0968	Double reeving	
0980	Low headroom trolley (includes mounting adaptor) Beam flange width: 2 ⁵ / ₈ " - 5 ⁵ / ₈ " Minimum radius curve: 24"	
0981	Trolley mounting adaptor	
0982	Unified suspension bracket	
0983	Gorbel suspension bracket 250/500	
0984	KBK I, II and 100 suspension bracket	
0923	CM Light rail	
09820	Chain bag	
1086	Latchlok hook kit	

Mounting adaptors available for all types of rail systems.

CM Max optional low headroom trolley For operation on American standard S-beams

Will also operate on flat flanged beams

* **WARNING**

Overloading and improper use can result in injury.

To avoid injury:

- Do not exceed working load limit, load rating capacity
- Do not use to lift people or loads over people.
- use only alloy chain for overhead lifting.
- Read and follow all instructions.

Gorbel Trolley Truck CM #0983

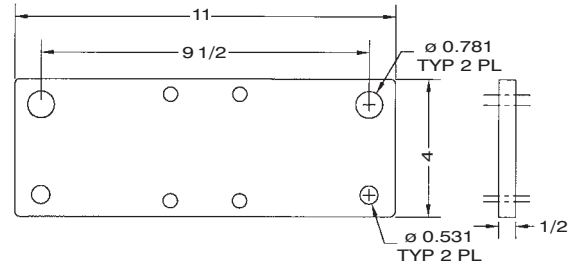

KBK Suspension Adapter CM #0984

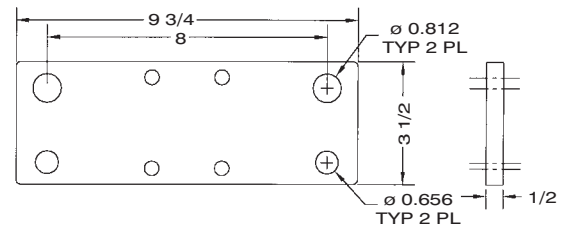

CM Suspension Adapter CM #0923

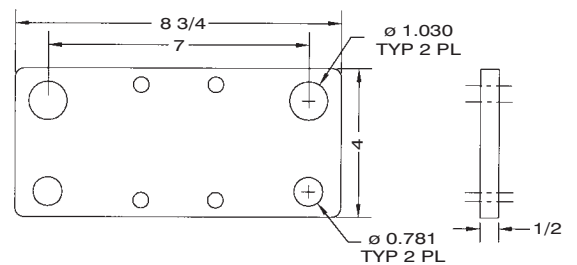

TMM-140 Air Manipulator Hoist



300 Lb./140Kg Air Manipulator Hoist

The **CM TMM-140** is ideal for workstation applications. Lightweight and portable, the unit weighs less than 20 pounds and operates at 100% (A5) duty cycle.

- **Smooth operator** - Efficient rotary vane motor provides high uniform torque for quick response, and smooth, quiet operation.
- **Easy to use** - Handle-mounted pendant control for one-handed operation and load positioning.
- **Variable speeds** - Precise and infinite speed control for accurate load spotting.
- **Wire rope design** - Self-winding lifting cable stores conveniently inside unit.
- **Suspension** - Swivel top and bottom hooks with hook latches standard, for portability and quick installation.
- **Disc brake** - Secures load and eliminates drift when pendant is released.
- **Note** - A 3/8" NPT air filter-regulator-lubricator is needed for effective operation. Spark resistant features are not available.

Ideal Applications Include:

- Assembly lines
- Machine shops
- Cleaning and/or dipping operations
- Manufacturing plants
- Power generating stations
- Shipping departments
- Chemical facilities
- Fabricating shops
- Repetitive lifting applications
- Auto and truck repair
- Handling fixtures and dies



TMM-140 Air Manipulator Hoist-Specifications

MODEL TMM-140

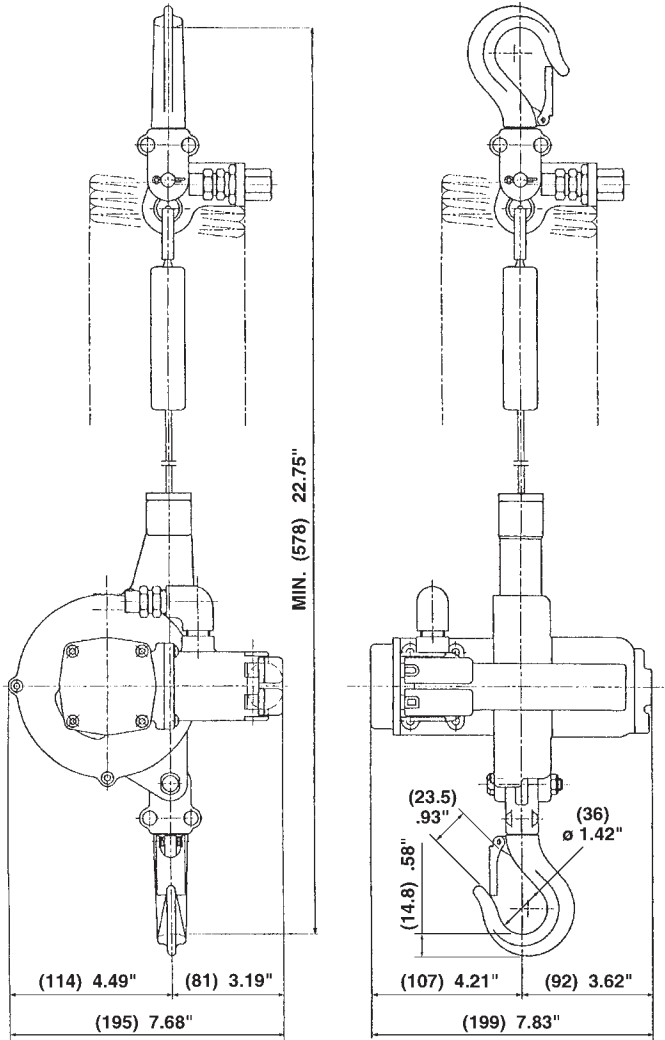

NOTE: Dimensions in parenthesis are in millimeters, other dimensions in inches. Top and bottom hook dimensions are the same.

*** ⚠ WARNING**

Overloading and improper use can result in injury.

To avoid injury:

- Do not exceed working load limit, load rating capacity
- Do not use to lift people or loads over people.
- use only alloy chain for overhead lifting.
- Read and follow all instructions.

Specifications:

Capacity (lb.)	Model number	Product code	Std. lift (ft.)	Lift speeds (FPM)				Air consumption		Headroom (in.)	Housing dimen. (in.)			Max air pres. (psi)	Net wt. (lb.)
				Load (up)	(Down)	No load (up)	(Down)	(m ³ /min)	(ft ³ /min)		D	W	L		
300	TMM-140	17050W	6' 6"	36	59	49	39	0.6	2½	22¾	7⅔	7⅞	23¾	70-95	18.7

Hurricane 360°

The New CM Hurricane unleashes a full circle of flexibility for lifting and pulling.

- **Standard Load Limiter** - For simple, automatic overload protection.
- **Improved Braking Power** - With its braking system, the CM Hurricane is exceptionally quiet, and improves operational safety and serviceability.
- **Powder Coated Finish** - For corrosion protection.
- **Heat Treated Steel Gearing** - All internal gears and pinions are heat treated steel for high strength and long life.
- **Chain Guide and Stripper** - Assures load chain alignment.
- **Precision 4-Pocket Liftwheel** - Fully machined for better chain fit and reduced wear allowing for accurate movement of the load chain.
- **Hardened Steel Chain** - Alloy steel load chain assures high strength and long wear life.
- **Minimal Maintenance** - Easily disassembled, requiring no special tools.
- **Meets ASME B30.16** - And European **CE** Standard
- **5-Year Warranty** - Against defects in materials and workmanship.



Sealed Ball Bearings and Sliding Bushings



New Patented Brake System

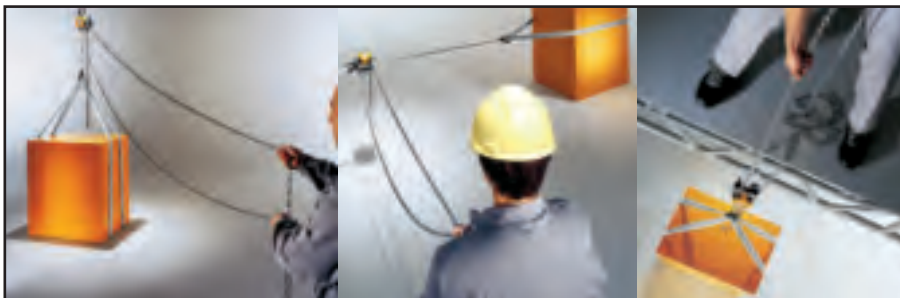

Standing away from load

Pulling application

Used inverted for easy rigging

* ⚠ **WARNING**

Overloading and improper use can result in injury.

To avoid injury:

- Do not exceed working load limit, load rating capacity
- Do not use to lift people or loads over people.
- use only alloy chain for overhead lifting.
- Read and follow all instructions.

Hurricane 360°

CM Hurricane—Specifications

Product code	Rated capacity		Standard lift		Hand chain pull to lift rated load		Hand chain overhaul to lift load 1ft.		Number of chain falls	Approximate shipping weight	
	(tons)	(kg)	(ft.)	(m)	(lbs.)	(kg)	(ft.)	(m)		(lbs.)	(kg)
5623	1/2 ton	500	8ft.	2.4	44	20	30	9.1	1	18.5	9
5624	1/2 ton	500	12ft.	2.4	44	20	30	9.1	1	23.0	10
5625	1/2 ton	500	20ft.	6.0	44	20	30	9.1	1	29.3	11
5626	1 ton	1000	8ft.	2.4	54	24	49	14.9	1	26.5	13
5627	1 ton	1000	12ft.	2.4	54	24	49	14.9	1	28.7	14
5628	1 ton	1000	20ft.	6.0	54	24	49	14.9	1	39.7	16
5629	2 ton	2000	8ft.	2.4	74	34	71	21.6	1	42.1	20
5630	2 ton	2000	12ft.	3.6	74	34	71	21.6	1	47.8	22
5631	2 ton	2000	20ft.	6.0	74	34	71	21.6	1	60.4	25
5635	3 ton	3000	8ft.	2.4	92	42	87	26.0	1	67.9	28
5636	3 ton	3000	12ft.	3.6	92	42	87	26.0	1	76.0	31
5637	3 ton	3000	20ft.	6.0	92	42	87	26.0	1	91.9	36
5639	5 ton	5000	8ft.	2.4	76	34	174	53.0	2	87.7	38
5640	5 ton	5000	12ft.	3.6	76	34	174	53.0	2	95.8	43
5641	5 ton	5000	20ft.	6.0	76	34	174	53.0	2	111.7	54
5643	10 ton	10000	8ft.	2.4	102	46	261	79.3	3	148.5	71
5644	10 ton	10000	12ft.	3.6	102	46	261	79.3	3	166.0	79
5645	10 ton	10000	20ft.	6.0	102	46	261	79.3	3	202.7	95

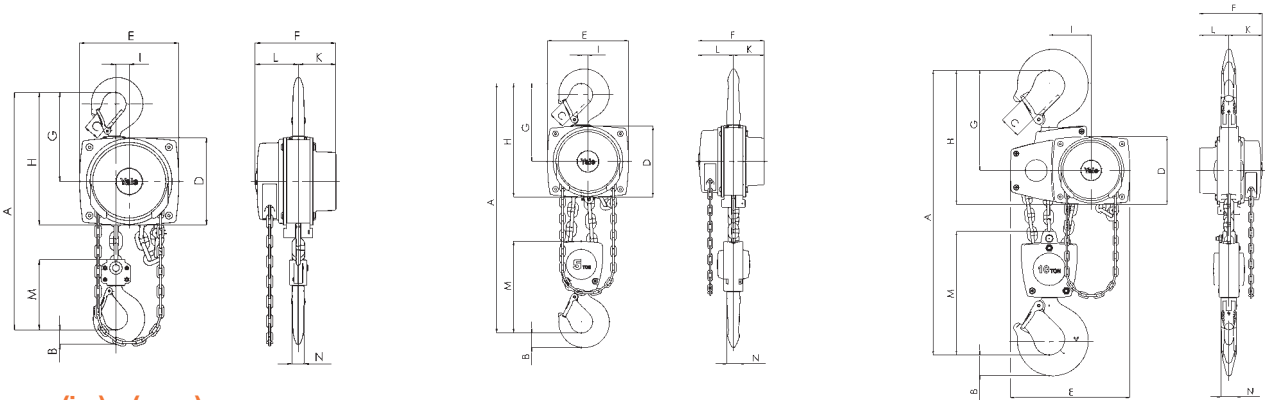

Dimensions - (in.) (mm.)

	A		B		C		D		E		F		G		H		I		K		L		M		N	
	(in.)	(mm.)	(in.)	(mm.)	(in.)	(mm.)	(in.)	(mm.)	(in.)	(mm.)	(in.)	(mm.)	(in.)	(mm.)	(in.)	(mm.)	(in.)	(mm.)	(in.)	(mm.)	(in.)	(mm.)	(in.)	(mm.)	(in.)	(mm.)
1/2 Ton 500 kg	11 13/16	300.0	11/16	17.0	15/16	24.0	5 1/4	133.0	5 13/16	148.0	6 1/4	159.3	5 1/2	139.0	8 1/16	205.5	15/16	24.2	2 3/8	60.5	3 7/8	98.8	4 5/16	110.0	7/16	11.0
1 Ton 1000 kg	14	355.0	7/8	22.0	1 1/8	29.0	6 1/8	156.0	6 7/8	175.0	6 15/16	176.3	6 7/16	164.0	9 1/2	242.0	15/16	23.6	2 3/4	70.0	4 3/16	106.3	4 5/16	125.0	9/16	15.0
2 Ton 2000 kg	15 9/16	395.0	1 3/16	30.0	1 3/8	35.0	7 3/16	182.0	8	203.0	8	202.5	7 9/16	192.0	11 1/4	283.0	1 1/4	31.4	3 1/4	82.5	4 3/4	120.0	6 1/8	156.0	13/16	21.0
3 Ton 3000 kg	20 1/2	520.0	1 1/2	38.0	1 9/16	40.0	8 11/16	220.0	9 13/16	250.0	8 13/16	232.2	8 7/8	225.0	13 3/16	335.5	15/16	33.5	3 3/4	95.0	5 1/16	128.2	7	178.0	1	26.0
5 Ton 5000 kg	25 3/16	640.0	1 3/4	45.0	1 7/8	47.0	8 11/16	220.0	9 13/16	250.0	8 13/16	232.2	9 1/2	241.5	13 3/16	351.5	13/16	20.5	3 3/4	95.0	5 1/16	128.2	11 13/16	284.5	1 3/16	30.0
10 Ton 10000 kg	32 1/2	825.0	2 11/16	67.5	2 11/16	68.0	8 11/16	220.0	9 13/16	250.0	8 13/16	232.2	12 13/16	325.5	17 1/8	435.5	5 3/8	136.0	3 3/4	95.0	5 1/16	128.2	15 13/16	401.0	1 9/16	40.0



Cyclone hand chain hoist



One of the most popular and reliable hoists ever designed, the Cyclone combines superior engineering, efficiency and durability. Available in a variety of capacities from 1/4 ton to 10 tons, Cyclone features:

- Most interchangeability of parts in the industry
- Standard Load Limiter for simple, automatic overload protection
- Enclosed contoured Weston-type automatic brake for positive load control
- High-efficiency spur gearing for greater lift with minimum effort
- Rugged Hoistaloy chain for added strength and durability
- Fully machined, forged liftwheel pockets for easier lifting and smooth free chaining

* WARNING

Overloading and improper use can result in injury.

To avoid injury:

- Do not exceed working load limit, load rating capacity
- Do not use to lift people or loads over people.
- use only alloy chain for overhead lifting.
- Read and follow all instructions.

-
- High-strength aluminum alloy castings in frame and covers
 - Inspected over 75 times to meet or exceed HMI and ASME/ANSI performance and safety standards
 - Standard hand chain drop is 2 feet less than lift, (example: 8 foot lift hoist has 6 foot hand chain drop)
 - Lifetime warranty
 - Metric rated
 - Made in U.S.A.
-

Options Include:

- Fabric chain bags
- Metal chain containers
- Zinc-plated load and hand chain
- Unwelded hand chain
- Latchlok hooks
- Bronze hooks
- Bullard hooks
- Eye-type suspension



Cyclone hand chain hoist-Specifications

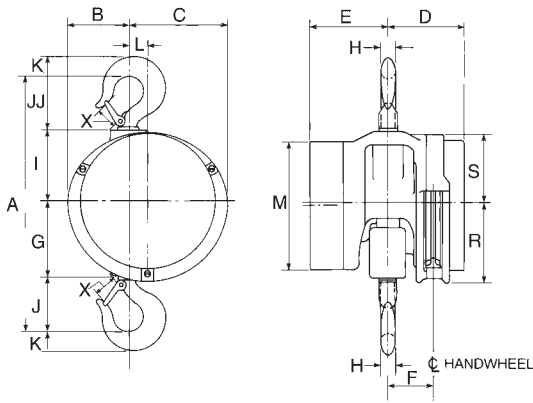

1/4 - 2 ton

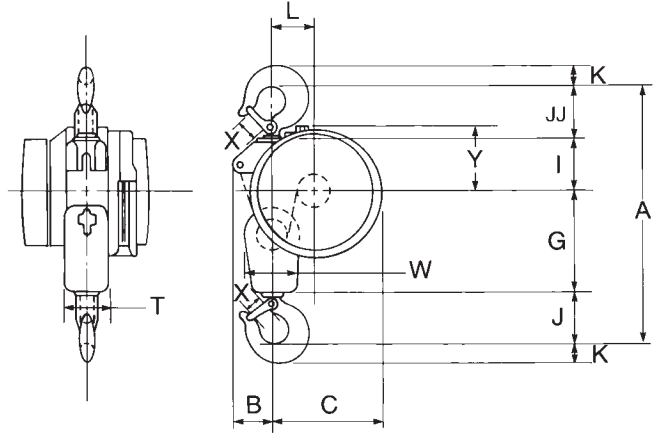
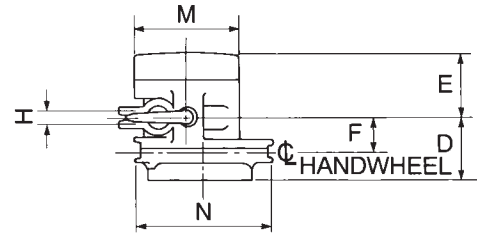

3 - 4 ton

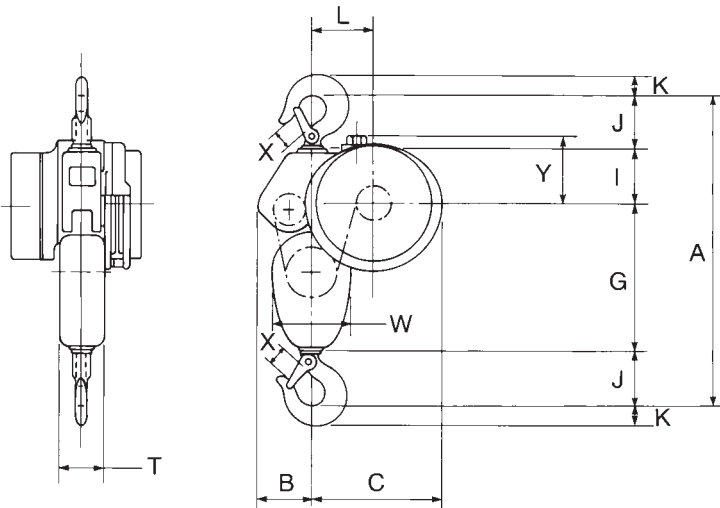
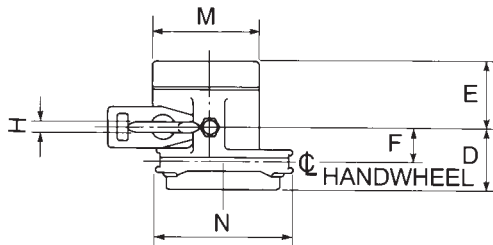

5 - 6 ton

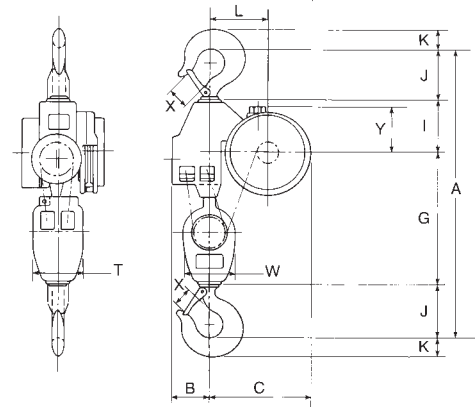
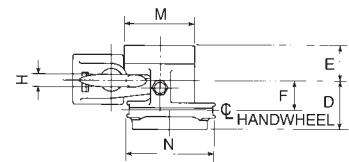

8 - 10 ton

Cyclone hand chain hoist-Specifications

Specifications

Rated capacity* (tons)	Product code	Standard lift† (ft.)	Reeving	Minimum distance between hooks (in.)	Chain overhauled to lift load one foot (ft.)	Chain pull to lift full load (lbs.)	Shipping weight (lbs.)
1/4	4621	8	1	12 ⁷ / ₈	22 ¹ / ₂	23	37
1/2	4622	8	1	12 ⁷ / ₈	22 ¹ / ₂	46	37
1	4624	8	1	14	30	69	40
1 1/2	4625	8	1	17 ⁵ / ₁₆	40 ¹ / ₂	80	65
2	4626	8	1	17 ⁵ / ₁₆	52	83	64
3	4627	8	2	21 ¹ / ₂	81	85	96
4	4628	8	2	21 ¹ / ₂	104	88	96
5	4629	8	3	24 ¹ / ₄	156	75	128
6	4630	8	3	25 ¹ / ₄	156	90	132
8	4631	8	4	34 ¹ / ₂	208	89	235
10	4632	8	5	35 ¹ / ₂	260	95	249

† Can be supplied with longer lifts

Clearance dimensions (in.)

Dimension	Rated capacity* (tons)								
	1/4	1/2	1	1 1/2 & 2	3 & 4	5	6	8	10
A	12 ⁷ / ₈	12 ⁷ / ₈	14	17 ⁵ / ₁₆	21 ¹ / ₂	24 ¹ / ₄	25 ¹ / ₄	34 ¹ / ₂	35 ¹ / ₂
B	3 ¹¹ / ₁₆	3 ¹¹ / ₁₆	3 ¹¹ / ₁₆	4 ³ / ₁₆	3 ⁵ / ₁₆	4 ³ / ₁₆	4 ³ / ₁₆	4 ³ / ₄	4 ³ / ₄
C	7 ³ / ₁₆	7 ³ / ₁₆	7 ³ / ₁₆	6 ¹¹ / ₁₆	8 ¹⁵ / ₁₆	10 ⁵ / ₁₆	10 ⁵ / ₁₆	12 ³ / ₄	12 ³ / ₄
D	4 ¹ / ₈	4 ¹ / ₈	4 ¹ / ₈	5 ¹ / ₁₆	5 ¹ / ₁₆	4 ⁷ / ₈	4 ⁷ / ₈	5 ¹³ / ₁₆	5 ¹³ / ₁₆
E	3 ¹ / ₄	3 ¹ / ₄	3 ¹ / ₄	4 ¹³ / ₁₆	4 ¹³ / ₁₆	5	5	4 ¹ / ₁₆	4 ¹ / ₁₆
F	2 ¹ / ₁₆	2 ¹ / ₁₆	2 ¹ / ₁₆	3 ¹ / ₈	3	2 ¹⁵ / ₁₆	2 ¹⁵ / ₁₆	3 ³ / ₄	3 ³ / ₄
G	3 ⁷ / ₈	3 ⁷ / ₈	3 ³ / ₄	5 ³ / ₁₆	8 ¹ / ₄	11 ¹³ / ₁₆	11 ¹³ / ₁₆	17 ³ / ₁₆	17 ³ / ₁₆
H	1 ¹ / ₁₆	1 ¹ / ₁₆	1 ³ / ₁₆	1 ¹ / ₈	1 ¹ / ₄	1 ¹ / ₄	1 ³ / ₈	1 ¹¹ / ₁₆	1 ¹³ / ₁₆
I	3 ³ / ₄	3 ³ / ₄	3 ³ / ₄	4 ¹³ / ₁₆	4 ¹ / ₄	4 ³ / ₁₆	4 ³ / ₁₆	6 ¹ / ₁₆	6 ¹ / ₁₆
J	2 ⁵ / ₈	2 ⁵ / ₈	2 ¹⁵ / ₁₆	3 ⁵ / ₈	4 ¹ / ₈	4 ¹ / ₈	4 ⁵ / ₈	5 ⁵ / ₈	6 ¹ / ₈
JJ	2 ⁵ / ₈	2 ⁵ / ₈	3 ⁹ / ₁₆	3 ¹¹ / ₁₆	4 ⁷ / ₈	—	—	—	—
K	1 ⁵ / ₁₆	1 ⁵ / ₁₆	1 ¹ / ₈	1 ¹ / ₂	1 ¹¹ / ₁₆	1 ¹¹ / ₁₆	1 ⁷ / ₈	2 ¹ / ₄	2 ⁹ / ₁₆
L	1 ³ / ₄	1 ³ / ₄	1 ³ / ₄	1 ¹ / ₄	3 ¹ / ₂	4 ⁷ / ₈	4 ⁷ / ₈	7 ⁵ / ₁₆	7 ⁵ / ₁₆
M	7 ¹ / ₁₆	7 ¹ / ₁₆	7 ¹ / ₁₆	8 ⁵ / ₈	8 ⁵ / ₈	8 ⁵ / ₈	8 ⁵ / ₈	8 ⁵ / ₈	8 ⁵ / ₈
N	—	—	—	—	10 ⁷ / ₈	10 ⁷ / ₈	10 ⁷ / ₈	10 ⁷ / ₈	10 ⁷ / ₈
R	5 ⁷ / ₁₆	5 ⁷ / ₁₆	5 ⁷ / ₁₆	5 ⁷ / ₁₆	—	—	—	—	—
S	4 ¹¹ / ₁₆	4 ¹¹ / ₁₆	4 ¹¹ / ₁₆	4 ¹¹ / ₁₆	—	—	—	—	—
T	—	—	—	—	3 ⁷ / ₈	4	4	6 ³ / ₈	6 ³ / ₈
W	—	—	—	—	4 ¹ / ₂	6 ¹ / ₄	6 ¹ / ₄	6 ⁷ / ₁₆	6 ⁷ / ₁₆
X	1 ¹ / ₃₂	1 ¹ / ₃₂	1 ¹ / ₈	1 ⁵ / ₁₆	1 ⁵ / ₈	1 ⁵ / ₈	1 ³ / ₄	2 ¹ / ₁₆	2 ⁵ / ₁₆
Y	—	—	—	—	5 ¹ / ₈	5 ⁷ / ₈	5 ⁷ / ₈	5 ⁹ / ₁₆	5 ⁹ / ₁₆

*** ⚠ WARNING**

Overloading and improper use can result in injury.

To avoid injury:

- Do not exceed working load limit, load rating capacity
- Do not use to lift people or loads over people.
- use only alloy chain for overhead lifting.
- Read and follow all instructions.

Cyclone Army type trolley hoist



Same quality and performance as the Cyclone in a compact, low headroom integral trolley mount. Ideal for applications requiring a moveable hoist including:

- Rugged steel loadbars connected directly to hoist frame
- Reduced headroom, side clearances and end approach for easy maneuvering of heavy loads in tight places
- Standard Load Limiter automatic overload protection
- Plain and geared trolley mounts in capacities from 1/4 to 12 tons
- Universal tread trolley wheels for operation on sloped or flat flanged beams
- Standard hand chain drop 2 feet less than lift (example: 8 foot lift hoist has 6 foot hand chain drop)
- Chain containers, zinc-plated load and hand chain, aluminum unwelded hand chain, Latchlok hooks, bronze hooks, bullard hooks, larger beam trolleys, trolley guards, and units without Load Limiter optional, depending on capacity
- Lifetime warranty
- Metric rated
- Made in U.S.A.

* ⚠ WARNING
Overloading and improper use can result in injury.
To avoid injury: <ul style="list-style-type: none"> • Do not exceed working load limit, load rating capacity • Do not use to lift people or loads over people. • use only alloy chain for overhead lifting. • Read and follow all instructions.

Specifications

Rated capacity* (tons)	Product code		Standard lift (ft.)	Reeving	American standard depth (in.)†	Beam adjustment ranges flange width (in.)†	Chain pull to lift capacity loads (lbs.)	Chain overhauled to lift load one foot (ft.)	Min. headroom (in.)	Min. radius curve (in.)	Shipping weight (lbs.)	
	Plain trolley	Geared trolley									Plain trolley	Geared trolley
1/4	4521	4541	8	1	4-12**	2 ⁵ / ₈ -5 ¹ / ₂	23	22 1/2	11 3/4	30	66	108
1/2	4522	4542	8	1	4-12**	2 ⁵ / ₈ -5 ¹ / ₂	46	22 1/2	11 3/4	30	66	108
1	4524	4544	8	1	4-12**	2 ⁵ / ₈ -5 ¹ / ₂	69	30	11 3/4	30	78	130
1 1/2	4525	4545	8	1	6-15	3 ³ / ₈ -5 ⁵ / ₈	80	40 1/2	15 5/16	30	136	164
2	4526	4546	8	1	6-15	3 ³ / ₈ -5 ⁵ / ₈	83	52	15 5/16	30	136	164
3	4527	4547	8	2	7-15	3 ³ / ₈ -5 ⁵ / ₈	85	81	18 7/8	48	182	230
4	4528	4548	8	2	7-15	3 ³ / ₈ -5 ⁵ / ₈	87	104	18 7/8	48	182	230
5	4529	4549	8	3	8-18	4-6 1/4	74	156	23 1/2	60	268	300
6	4530	4550	8	3	8-18	4-6 1/4	89	156	24	60	273	305
8	4531	4551	8	4	12-24	5-8	91	208	28 1/4	72	506	589
10	4532	4552	8	5	12-24	5-8	93	260	28 1/4	72	513	596
12	4533	4553	8	6	15-24	5 1/2-8	95	312	30 3/8	96	1050	1130

** For 1/4 through 1 ton geared trolleys - minimum beam size S6 x 12.5 (3 3/8 flange width)

† Universal tread track wheels designed to operate on either sloped or flat flange beam, rails or tracks

Cyclone Army type trolley hoist-Specifications

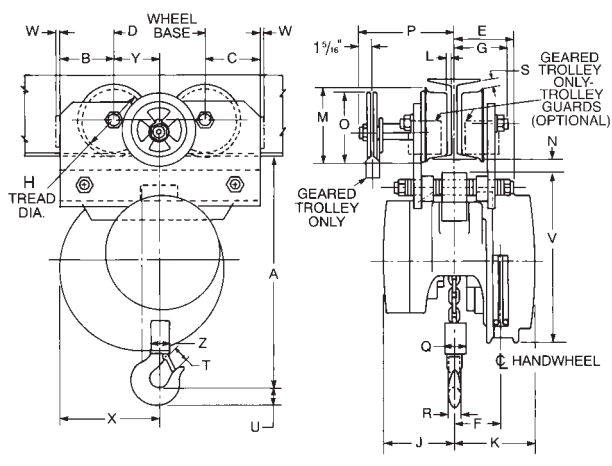

1/4-6 TON

1/4 - 6 ton

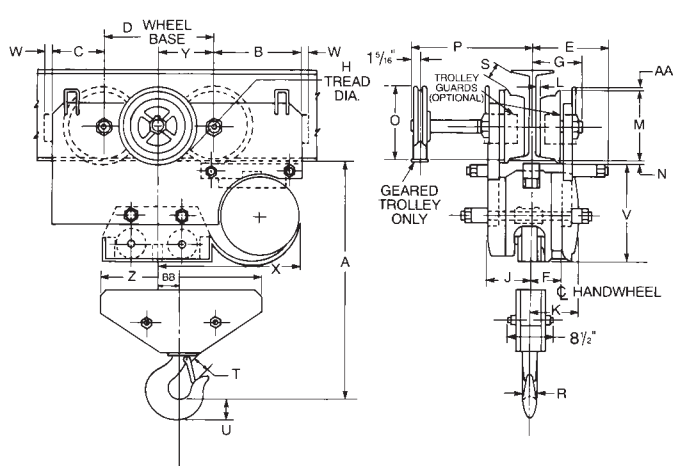

8 - 12 ton

Clearance dimensions (in.)

Dimension	Rated capacity* (tons)															
	1/4, 1/2 & 1		1 1/2 & 2		3 & 4		5		6		8		10		12	
	Plain	Geared	Plain	Geared	Plain	Geared	Plain	Geared	Plain	Geared	Plain	Geared	Plain	Geared	Plain	Geared
A	11 3/4	11 13/16	15 5/16	15 5/16	18 7/8	18 7/8	23 1/2	23 1/2	24	24	28 1/4	28 1/4	28 1/4	28 1/4	30 3/8	30 3/8
B	4 3/16	4 3/8	3 11/16	3 11/16	5 3/4	5 3/4	6 1/2	6 1/2	6 1/2	6 1/2	8 15/16	8 15/16	8 15/16	8 15/16	10 7/8	10 7/8
C	2 9/16	2 9/16	3 11/16	3 11/16	3 7/16	3 7/16	3 3/4	3 3/4	3 3/4	3 3/4	5 1/4	5 1/4	5 1/4	5 1/4	7 3/16	7 3/16
D	6	6	6	6	6 7/8	6 7/8	7 3/4	7 3/4	7 3/4	7 3/4	11	11	11	11	11	11
E	4 1/2	4 15/16	5	5	5 7/16	5 7/16	6 1/8	6 1/8	6 1/8	6 1/8	7 1/4	7 1/4	7 1/4	7 1/4	7 1/4	7 1/4
F	2 1/16	2 1/16	3 1/8	3 1/8	3	3	2 13/16	2 13/16	2 13/16	2 13/16	3	3	3	3	3	3
G	3	3 3/4	3 5/8	3 3/4	4 5/16	4 5/16	4 15/16	4 15/16	4 15/16	4 15/16	5 9/16	5 9/16	5 9/16	5 9/16	5 13/16	5 13/16
H	3 1/8	4	4 3/4	4	5	5	6	6	6	6	8	8	8	8	8	8
J	3 1/4	3 1/4	4 13/16	4 13/16	4 13/16	4 13/16	5	5	5	5	4 13/16	4 13/16	4 13/16	4 13/16	4 13/16	4 13/16
K	4 1/8	4 1/8	5 1/16	5 1/16	5 1/16	5 1/16	4 7/8	4 7/8	4 7/8	4 7/8	5 1/16	5 1/16	5 1/16	5 1/16	5 1/16	5 1/16
L	5/16	5/16	1/2	5/16	1/4	1/4	3/8	3/8	3/8	3/8	1/2	1/2	1/2	1/2	1 1/16	1 1/16
M	4	4 3/4	5 9/16	4 3/4	5 7/8	5 7/8	7	7	7	7	9 7/16	9 7/16	9 7/16	9 7/16	9 1/2	9 1/2
N	1/2	9/16	9/16	9/16	1 1/16	1 1/16	1 1/16	1 1/16	1 1/16	1 1/16	1/2	1/2	1/2	1/2	7/16	7/16
O	-	5 9/16	-	5 9/16	6 1/8	6 1/8	6 3/4	6 3/4	6 3/4	6 3/4	7 9/16	7 9/16	7 9/16	7 9/16	7 3/16	7 3/16
P	-	10	-	10	8 15/16	8 15/16	10 7/16	10 7/16	10 7/16	10 7/16	11 7/16	11 7/16	11 7/16	11 7/16	11 11/16	11 11/16
Q	2	2	2 1/2	2 1/2	3 7/8	3 7/8	4	4	4	4	11 5/16	11 5/16	-	-	-	-
R	1 1/16	1 1/16	1 1/8	1 1/8	1 1/4	1 1/4	1 1/4	1 1/4	1 3/8	1 3/8	1 13/16	1 13/16	1 13/16	1 13/16	2 3/8	2 3/8
S	1/16	15/16	3/16	15/16	15/16	15/16	3/4	3/4	3/4	3/4	2 3/16	2 3/16	2 3/16	2 3/16	5 1/16	5 1/16
T	1	1	1 3/8	1 3/8	1 5/8	1 5/8	1 5/8	1 5/8	1 3/4	1 3/4	2 5/16	2 5/16	2 5/16	2 5/16	3	3
U	7/8	7/8	1 1/8	1 1/8	1 11/16	1 11/16	1 11/16	1 11/16	1 7/8	1 7/8	2 9/16	2 9/16	2 9/16	2 9/16	3	3
V	10 1/8	10 1/8	11 3/8	11 3/8	11 3/8	11 3/8	11 3/8	1 3/8	11 3/8	11 3/8	11 5/8	11 5/8	11 5/8	11 5/8	11 5/8	11 5/8
W	1/4	3/8	3/8	3/8	1/2	1/2	5/8	5/8	5/8	5/8	5/8	5/8	5/8	5/8	5/8	5/8
X	7 3/16	7 3/16	6 11/16	6 11/16	8 15/16	8 15/16	10 5/16	10 5/16	10 5/16	10 5/16	14 7/16	14 7/16	14 7/16	14 7/16	16 3/8	16 3/8
Y	3	3	3	3	3 7/16	3 7/16	3 7/8	3 7/8	3 7/8	3 7/8	5 1/2	5 1/2	5 1/2	5 1/2	5 1/2	5 1/2
Z	2	2	2 1/2	2 1/2	4 1/2	4 1/2	6 1/4	6 1/4	6 1/4	6 1/4	13 15/16	13 15/16	18 3/16	18 3/16	21 11/16	21 11/16
AA	-	-	-	-	-	-	-	-	-	-	3/8	3/8	3/8	3/8	3/8	3/8
BB	-	-	-	-	-	-	-	-	-	-	1 15/16	1 15/16	0	0	0	0

Note: Dimensions are based on minimum beam and may vary with larger beams.

Cyclone trolley hoist for low headroom

Cyclone and trolley all in one unit for low headroom applications features:

- Crowned tread and flanged wheels to minimize rolling friction
- Simple, efficient design
- Reduced headroom, side clearances and end approach for easy maneuvering of loads in tight places
- Plain trolley mounts in capacities from 1/2 to 6 tons
- Geared trolley mounts in capacities from 1 1/2 to 6 tons
- Standard hand chain drop 2 feet less than lift (example: 8 foot lift hoist has 6 foot hand chain drop)
- Chain containers, zinc-plated load and hand chain, aluminum unwelded hand chain, Latchlok hooks, bronze hooks, bullard hooks, larger beam trolleys, trolley guards and units without Load Limiter optional, depending on capacity
- Standard Load Limiter/automatic overload protection
- Lifetime warranty
- Metric rated
- Made in U.S.A.

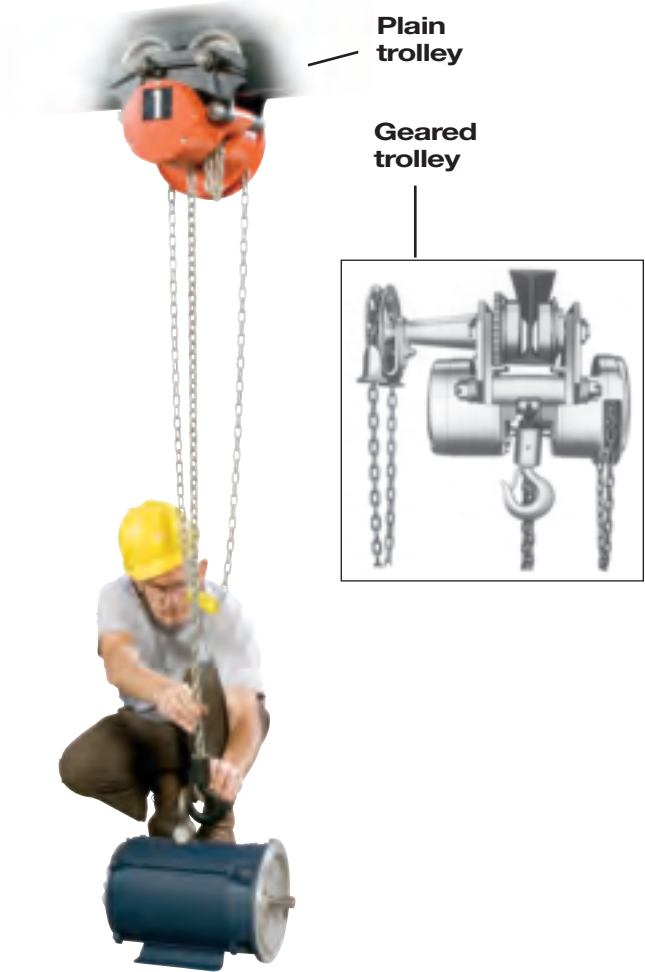

Specifications

Rated capacity* (tons)	Product code		Std. lift (ft.)	Reeving	American standard depth (in.)††	Beam adjustment ranges flange width (in.)††	Chain pull to lift full load (lbs.)	Chain overhauled to lift load one foot (ft.)	Min. headroom (in.)	Min. radius curve (in.)	Shipping weight (lbs.)	
	Plain trolley	Geared trolley									Plain trolley	Geared trolley
1/2	4832	—	8	1	6-12**†	3 ³ / ₈ -5	46	22 ¹ / ₂	8 ⁷ / ₈	36	88	—
1	4834	—	8	1	6-12**†	3 ³ / ₈ -5	69	30	9 ¹ / ₄	36	93	—
1 1/2	4835	4925	8	1	7-15**†	3 ⁵ / ₈ -5 ¹ / ₂	80	40 ¹ / ₂	12 ¹ / ₂	48	186	210
2	4836	4926	8	1	7-15†	3 ⁵ / ₈ -5 ¹ / ₂	83	52	12 ¹ / ₂	48	186	216
3	4837	4927	8	2	7-15†	3 ⁵ / ₈ -5 ¹ / ₂	85	81	14 ¹ / ₈	48	203	233
4	4838	4928	8	2	8-24†	4-7	88	104	16 ³ / ₄	96	308	372
5	4839	4929	8	3	8-24†	4-7	75	156	18 ¹ / ₄	96	328	370
6	4840	4930	8	3	8-24†	4-7	90	156	18 ³ / ₄	96	333	375

**1/2 and 1 ton also available for 4" and 5" S-beam, and 1 1/2 and 2 ton for 6" S-beam without extra charge

† Universal tread trackwheels designed to operate on either sloped or flat flange beams, rails, or tracks Also can be used on flat flange beams within the same range of flange widths, provided beam depth will accommodate wheel diameter (check clearance diagram)

†† Applies to minimum size S-beam within adjustability range

* **WARNING**

Overloading and improper use can result in injury.

To avoid injury:

- Do not exceed working load limit, load rating capacity
- Do not use to lift people or loads over people.
- use only alloy chain for overhead lifting.
- Read and follow all instructions.

Cyclone trolley hoist for low headroom-Specifications

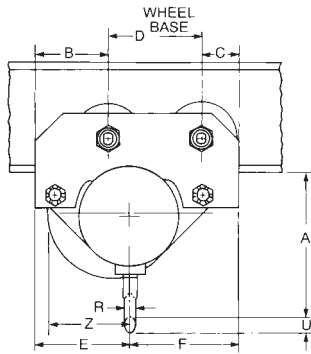

Plain trolley

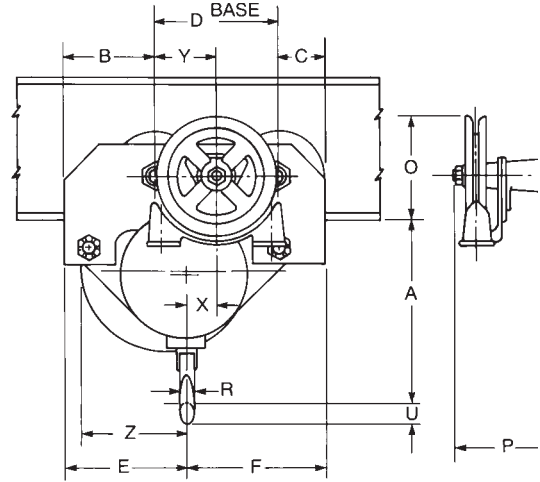
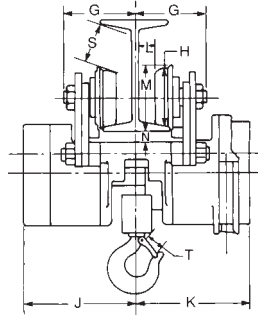

Geared trolley

Clearance dimensions (in.)

Dimension	Rated capacity* (tons)						
	1/2	1	1 1/2 & 2	3	4	5	6
A	8 ⁷ / ₈	9 ¹ / ₄	12 ¹ / ₂	14 ¹ / ₈	16 ³ / ₄	18 ¹ / ₄	18 ³ / ₄
B	3 ⁵ / ₈	3 ⁵ / ₈	6	6	7 ³ / ₈	7 ³ / ₈	7 ³ / ₈
C	3 ⁵ / ₈	3 ⁵ / ₈	3 ¹ / ₈	3 ¹ / ₈	4	4	4
D	6 ¹ / ₂	6 ¹ / ₂	7 ³ / ₄	7 ³ / ₄	9	9	9
E	6 ⁷ / ₈	6 ³ / ₄	7 ⁵ / ₈	10 ¹ / ₂	11	11 ⁷ / ₈	11 ⁷ / ₈
F	6 ³ / ₄	6 ⁷ / ₈	9 ¹ / ₄	6 ³ / ₈	9 ³ / ₈	8 ¹ / ₂	8 ¹ / ₂
G	3 ³ / ₄	3 ³ / ₄	5 ¹ / ₈	5 ¹ / ₈	5 ⁷ / ₈	5 ⁷ / ₈	5 ⁷ / ₈
H	4 ³ / ₄	4 ³ / ₄	4 ⁵ / ₈	4 ⁵ / ₈	5 ⁷ / ₈	5 ⁷ / ₈	5 ⁷ / ₈
J	6	6	9 ⁵ / ₁₆	9 ⁵ / ₁₆	10 ⁹ / ₁₆	10 ⁹ / ₁₆	10 ⁹ / ₁₆
K	8 ¹ / ₈	8 ¹ / ₈	9 ⁵ / ₈	9 ⁵ / ₈	11	11	11
L	1 ¹ / ₂	1 ¹ / ₂	1 ¹ / ₂	1 ¹ / ₂	1 ¹ / ₂	1 ¹ / ₂	1 ¹ / ₂
M	5 ⁷ / ₁₆	5 ⁷ / ₁₆	5 ³ / ₈	5 ³ / ₈	6 ³ / ₄	6 ³ / ₄	6 ³ / ₄
N	1	1	1	1	1 ¹ / ₈	1 ¹ / ₈	1 ¹ / ₈
O	—	—	6 ³ / ₄	6 ³ / ₄	6 ¹ / ₂	6 ¹ / ₂	6 ¹ / ₂
P	—	—	4 ⁷ / ₈	4 ⁷ / ₈	4 ¹ / ₄	4 ¹ / ₄	4 ¹ / ₄
R	1 ¹ / ₁₆	1 ³ / ₁₆	1 ¹ / ₈	1 ¹ / ₄	1 ¹ / ₄	1 ¹ / ₄	1 ³ / ₈
S	5 ¹ / ₁₆	5 ¹ / ₁₆	1 ³ / ₈	1 ³ / ₈	1 ¹ / ₁₆	1 ¹ / ₁₆	1 ¹ / ₁₆
T	1 ¹ / ₃₂	1 ¹ / ₈	1 ⁵ / ₁₆	1 ⁵ / ₈	1 ⁵ / ₈	1 ⁵ / ₈	1 ³ / ₄
U	1 ⁵ / ₁₆	1 ¹ / ₈	1 ¹ / ₂	1 ¹¹ / ₁₆	1 ¹¹ / ₁₆	1 ¹¹ / ₁₆	1 ⁷ / ₈
W	—	—	5 ⁵ / ₈	5 ⁵ / ₈	7	7	7
X	—	—	2 ¹ / ₄	5 ⁵ / ₈	7 ⁷ / ₈	—	—
Y	—	—	3 ⁷ / ₈	3 ⁷ / ₈	4 ¹ / ₂	4 ¹ / ₂	4 ¹ / ₂
Z	7 ³ / ₈	7 ¹ / ₄	6 ⁵ / ₈	9 ¹ / ₂	9 ¹ / ₂	10 ³ / ₈	10 ³ / ₈

Note: Dimensions G, L, M, O, P, S & W are shown for minimum S-beam and increase proportionally for larger beams. Dimension N is shown for minimum S-beam and decreases proportionally for larger beams.

Cyclone Fabric Chain Bags



Cyclone, Army type and low headroom trolley hoist optional fabric chain bags

Product code		Rated capacity* (tons)	Maximum length of lift (ft.)	Bag diameter (in.)	Bag length (in.)	Approx. weight (lbs.)
Cyclone and Army type	Low headroom trolley hoist					
2482	2493	1/4-1/2	18	7	7 1/2 x 7 1/2	3
2483	2488	1/4-1/2	18.1-36	10	7 1/2 x 7 1/2	3
2484	2495	1/4-1/2	36.1-54	13	7 1/2 x 7 1/2	3
2485	2496	1/4-1/2	54.1-78	16	7 1/2 x 7 1/2	4
2486	2497	1/4-1/2	78.1-93	18	7 1/2 x 7 1/2	4
2487	2498	1/4-1/2	93.1-129	20	7 1/2 x 7 1/2	4
2482	2493	1	11	7	7 1/2 x 7 1/2	3
2483	2494	1	11.1-24	10	7 1/2 x 7 1/2	3
2484	2495	1	24.1-37	13	7 1/2 x 7 1/2	3
2485	2496	1	37.1-55	16	7 1/2 x 7 1/2	4
2486	2497	1	55.1-66	18	7 1/2 x 7 1/2	4
2487	2498	1	66.1-92	20	7 1/2 x 7 1/2	4
2488	2488	1 1/2-2	13	10	7 1/2 x 7 1/2	3
2489	2489	1 1/2-2	13.1-20	13	7 1/2 x 7 1/2	3
2490	2490	1 1/2-2	20.1-29	16	7 1/2 x 7 1/2	4
2491	2491	1 1/2-2	29.1-35	18	7 1/2 x 7 1/2	4
2492	2492	1 1/2-2	35.1-49	20	7 1/2 x 7 1/2	4
2489	2489	3-4	10	13	7 1/2 x 7 1/2	3
2490	2490	3-4	10.1-15	16	7 1/2 x 7 1/2	4
2491	2491	3-4	15.1-18	18	7 1/2 x 7 1/2	4
2492	2492	3-4	18.1-25	20	7 1/2 x 7 1/2	4
2490	2490	5-6	10	16	7 1/2 x 7 1/2	4
2491	2491	5-6	10.2-12	18	7 1/2 x 7 1/2	4
2492	2492	5-6	12.1-17	20	7 1/2 x 7 1/2	4
2491	2491	8	8	18	7 1/2 x 7 1/2	4
2492	2492	8	8.1-12	20	7 1/2 x 7 1/2	4
2492	2492	10	10	20	7 1/2 x 7 1/2	4

Cyclone Chain Containers



Cyclone, Army type and low headroom trolley hoist optional metal chain containers

Product code		Rated capacity* (tons)	Maximum length of lift (ft.)	Bucket length (in.)	Bucket diameter (in.)	Approximate weight (lbs.)
Cyclone and Army type	Low headroom trolley hoist					
4603S-373S	4614S-329S	1/4-1/2	9	8	5	3
4603S-373S	4614S-330S	1/4-1/2	9.1-18	11	5	4
4603S-375S	4614S-331S	1/4-1/2	18.1-27	14	5	4
4603S-376S	4614S-332S	1/4-1/2	27.1-36	17	5	5
4603S-377S	4614S-333S	1/4-1/2	45	20	5	6
4603S-378S	4614S-334S	1/4-1/2	45.1-54	23	5	6
4603S-379S	4614S-335S	1/4-1/2	54.1-78	31	5	8
4603S-380S	4614S-336S	1/4-1/2	78.1-93	36	5	9
4603S-381S	4614S-337S	1/4-1/2	93.1-129	48	5	12
4063S-382S	4614S-339S	1	11	11	5	4
4603S-383S	4614S-340S	1	11.1-18	14	5	4
4603S-384S	4614S-341S	1	18.1-24	17	5	5
4603S-385S	4614S-342S	1	24.1-31	20	5	6
4603S-386S	4614S-343S	1	31.1-37	23	5	6
4603S-387S	4614S-344S	1	37.1-55	31	5	8
4603S-388S	4614S-345S	1	55.1-66	36	5	9
4603S-389S	4614S-346S	1	66.1-92	48	5	12
4603S-352S	4614S-352S	1 1/2-2	9	14	5	4
4603S-353S	4614S-353S	1 1/2-2	9.1-13	17	5	5
4603S-354S	4614S-354S	1 1/2-2	13.1-16	20	5	6
4603S-355S	4614S-355S	1 1/2-2	16.1-20	23	5	6
4603S-356S	4614S-356S	1 1/2-2	20.1-29	31	5	8
4603S-357S	4614S-357S	1 1/2-2	29.1-35	36	5	9
4603S-358S	4614S-358S	1 1/2-2	35.1-49	48	5	12
4603S-394S	—	3-4	8	20	5	6
4603S-360S	4614S-360S	3-4	10	23	5	6
4603S-361S	4614S-361S	3-4	10.1-15	31	5	8
4603S-362S	4614S-362S	3-4	15.1-18	36	5	9
4603S-363S	4614S-363S	3-4	18.1-25	48	5	12
4603S-367S	4614S-367S	5-6	10	31	5	8
4603S-368S	4614S-368S	5-6	10.1-12	36	5	9
4603S-369S	4614S-369S	5-6	12.1-17	48	5	12
4603S-395S	—	8	8	36	5	9
4603S-396S	—	8	8.1-12	48	5	12
4603S-397S	—	10	10	48	5	12

Series 622 hand chain hoist

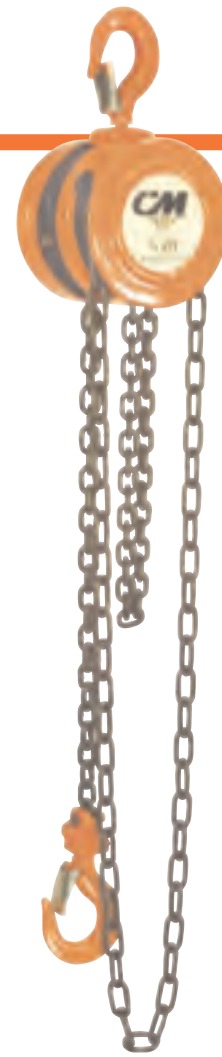

- Simple, efficient, economical design
- Equipped with hardened load chain for flexibility and long wear
- Compact design, low headroom and lightweight steel construction for easy installation, even in confined spaces
- Weston-type load brake requires no lubrication
- Hand wheel cover with guide slots minimizes jamming and slipping
- Forged swivel hooks with latches reduce twisting of chain and unintentional unhooking of load when chain is slack
- Standard hand chain drop is 2 feet less than lift (example: 8 foot lift hoist has 6 foot hand chain drop)
- One-year warranty
- Metric rated
- Imported

Specifications

Product code	Rated capacity* (tons)	Standard lift (ft.)	Chain pull to lift rated load (lbs.)	Hand chain overhauled to lift load one foot (ft.)	Approx. shipping weight (lbs.)
2202	1/2	8	53	29	15
2216	1/2	12	53	29	22
2208	1/2	15	53	29	25
2231	1/2	20	53	29	30
2263	1/2	30	53	29	38
2204	1	8	77	37	22
2217	1	12	77	37	29
2210	1	15	77	37	32
2262	1	20	77	37	38
2264	1	30	77	37	48
2206	2	8	82	80	57
2218	2	12	82	80	6
2213	2	15	82	80	71
2233	2	20	82	80	80
2272	2	30	85	80	85
2207	3	8	65	154	85
2230	3	12	65	154	93
2214	3	20	65	154	109
2209	5	8	105	147	82
2215	5	12	105	147	96
2234	5	20	105	147	123
2212	10	8	109	289	164

Series 622 hand chain hoist-Specifications

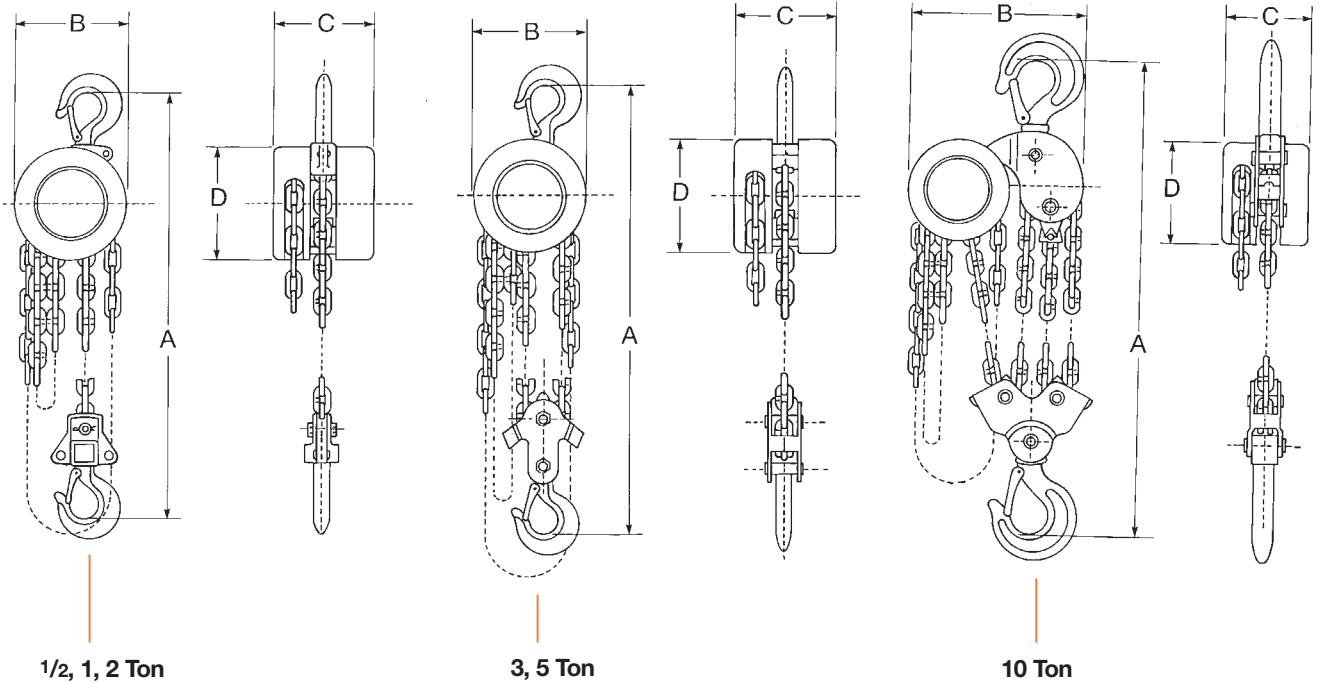

*** ⚠ WARNING**

Overloading and improper use can result in injury.

To avoid injury:

- Do not exceed working load limit, load rating capacity
- Do not use to lift people or loads over people.
- use only alloy chain for overhead lifting.
- Read and follow all instructions.

Clearance dimensions (in.)

Dimension	Rated capacity* (tons)					
	1/2	1	2	3	5	10
A (Headroom)	11 ⁵ / ₈	13	18 ¹ / ₈	21 ²⁹ / ₃₂	23 ⁷ / ₈	27 ⁹ / ₁₆
B (Width)	4 ¹⁵ / ₁₆	5 ¹⁹ / ₃₂	8 ⁵ / ₁₆	8 ⁵ / ₁₆	8 ⁵ / ₁₆	14 ³ / ₃₂
C (Depth)	4 ⁵ / ₁₆	5 ¹ / ₁₆	6 ⁵ / ₈	6 ⁵ / ₈	6 ⁵ / ₈	6 ⁵ / ₈
D (Diameter)	4 ¹⁵ / ₁₆	5 ¹⁹ / ₃₂	8 ⁵ / ₁₆	8 ⁵ / ₁₆	8 ⁵ / ₁₆	8 ⁵ / ₁₆
Hook opening (upper)	1 ¹ / ₁₆	1 ¹ / ₃₂	1 ¹ / ₄	5 ¹ / ₁₆	1 ¹³ / ₁₆	2 ¹ / ₂
Hook opening (lower)	1 ¹ / ₁₆	1 ¹ / ₃₂	1 ¹ / ₄	5 ¹ / ₁₆	1 ¹³ / ₁₆	2 ¹ / ₂

Series 602/603 mini ratchet lever hoist

Mini-Ratchet Lever Hoists lift up to 1100 lbs. plus the convenience of toolbox storage.

The CM Series 603 & 602 Mini-Hoists are the most compact ratchet lever hoists in the market, perform just like the larger models, plus come standard with these great features:

- Plated load chain is standard.
- Weston-type load brake.
- Rubber hand grip for better comfort and security.
- Lightweight design for ease of portability. Use in confined conditions with one-hand operation.
- Forged upper and lower hooks with latches standard.
- Impact resistant, all-steel frame, gear case and cover.
- Hardened link-type alloy steel load chain for strength and long wear.
- Free wheeling feature serves to quickly attach the load.
- Metric rated.



5 Ft. & 10 Ft. Lifts

SPECIFICATIONS

Capacity (Lbs.)	Capacity (Kg.)	Model Number	Number of Chainfalls	Handle Length (In.)	Minimum Distance Between Hooks (In.)	Lift w/ One Full Lever Turn (In.)	Handle Pull @ W.L.L. (Lbs.)	Net Weight w/Standard Lift (Lbs.)
550	250	602	1	6.300	9.45	3.15	56	6.0
1100	500	603	1	6.375	11.125	1.57	78	7.0



Our compact Mini-Hoists perform just like the larger hoists, except they're small enough to fit in the palm of your hand.



Convenient Carry Bag - Product Code # 0212

Series 602 mini ratchet lever hoist-Specifications

Dimensional Drawing - 602

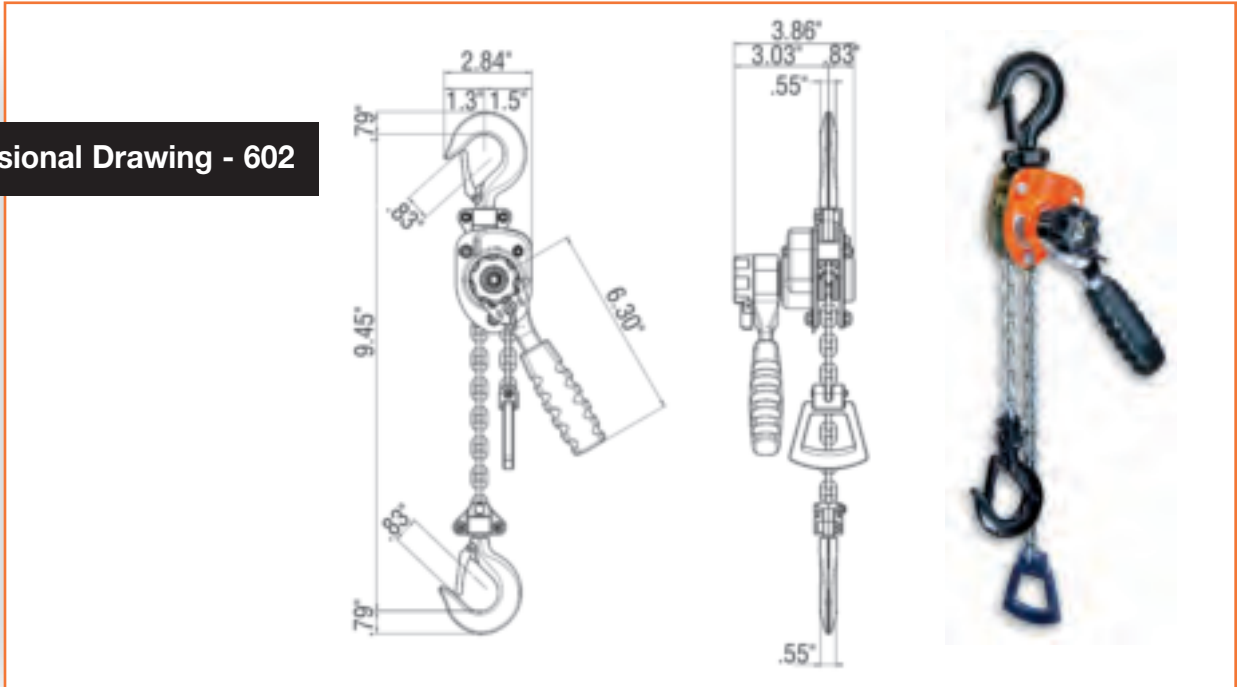

Dimensional Drawing - 603

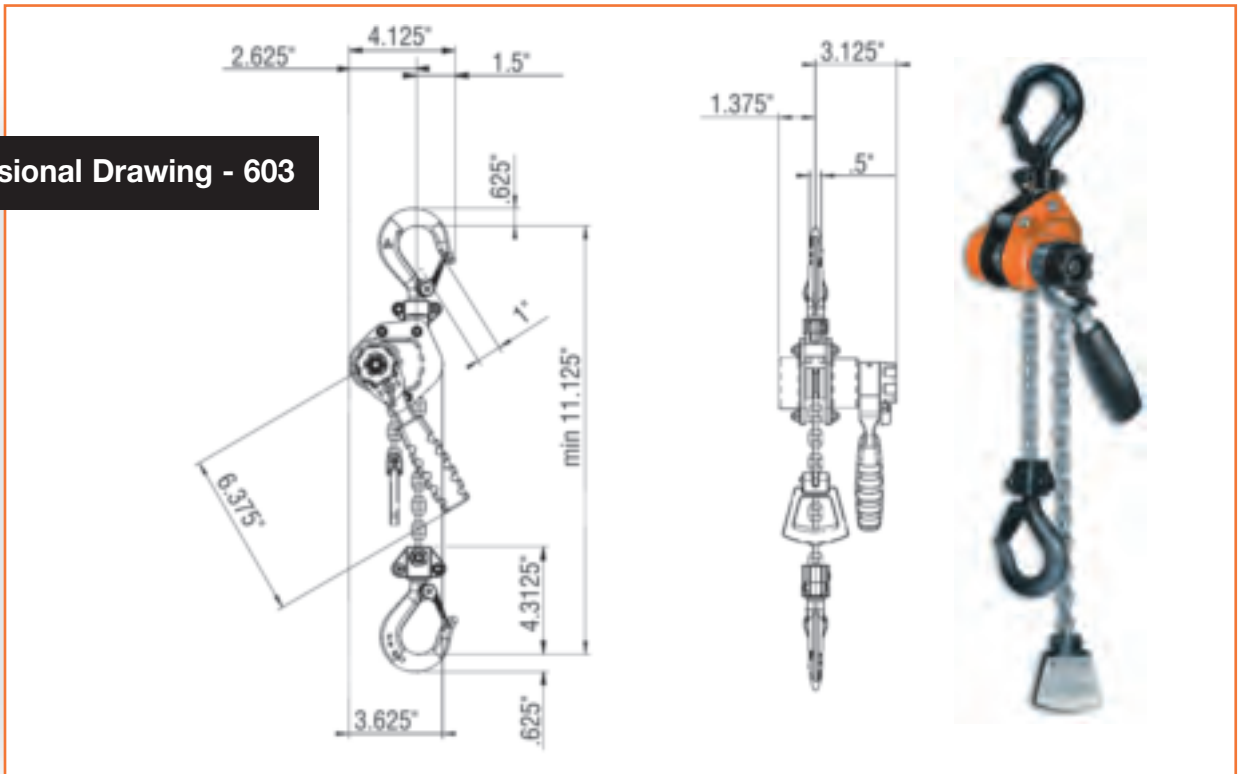

Series 653 Lever operated hoist

Ideal for construction and industrial applications

The Series 653 lever operated hoist is a high quality, rugged, steel tool for close quarter pulling, stretching, and hoisting applications. Its characteristic short handle, along with minimal lever pull effort, make this tool ideal for a broad range of applications.

- Capacities from 3/4 to 6 tons
- Impact resistant, stamped steel frame, gear case and cover for durability and light weight.
- Powder coated finish for added corrosion protection.
- Hardened steel load sharing gears.
- Double pawl arrangement for assured load control.
- Two chain guide rollers for positive chain engagement.
- Weston type braking system for positive load control and positioning.
- Simple one-handed, free chaining for fast load attachment.
- Hardened steel chain for strength and long wear life.
- Forged upper and lower hooks with heavy cast steel latches.
- Rubber handle grip for added operator comfort.
- Minimal maintenance with no special tools required.
- 5-year warranty against defects in materials and workmanship.
- Metric rated.
- Meets ASME B30.21 – Manually Lever Operated Hoist Standard and European CE Standard.
- Designed and manufactured by Columbus McKinnon Corporation.



Shipyards hooks are available for use with the Series 653 in shipbuilding and metal fabrication industries. The upper shipyard hook replaces the standard hook and easily attaches to the body of the hoist. The lower hook is furnished with a chain block for direct attachment to the load of the hoist. Shipyards hooks are excellent for positioning steel plate and fixtures during welding applications.

Series 533 lever operated hoist-Specifications

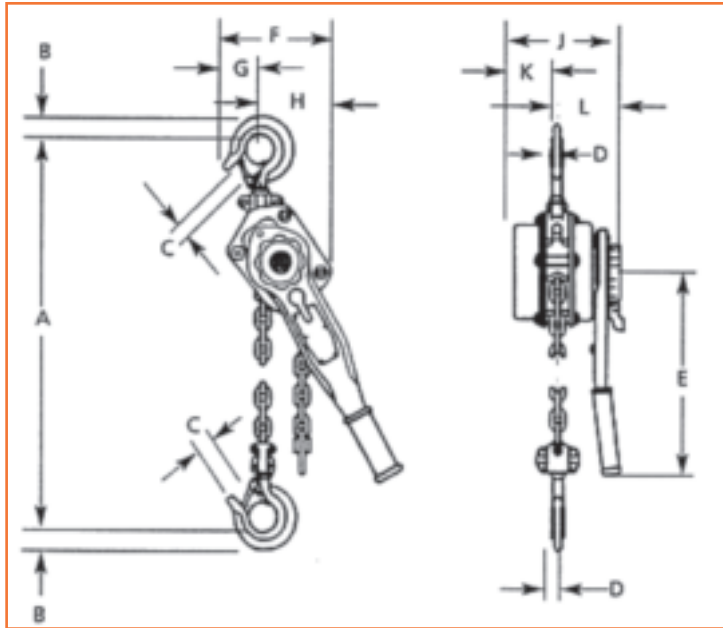

Specifications

Product code	Load rating (tonnes)	Lift or reach (ft.)	Lever pull to lift rated load (lbs.)	Approx. ship wt. (lbs.)	A	B	C	D	E	F	G	H	J	K	L
5310	3/4	5	33	15.0	12 ⁵ / ₈	15/16	1 ¹ / ₈	11/16	11	4 ³ / ₈	2 ³ / ₁₆	2 ³ / ₁₆	5 ¹⁵ / ₁₆	2 ³ / ₈	3 ⁹ / ₁₆
5311	3/4	10	33	15.8	12 ⁵ / ₈	15/16	1 ¹ / ₈	11/16	11	4 ³ / ₈	2 ³ / ₁₆	2 ³ / ₁₆	5 ¹⁵ / ₁₆	2 ³ / ₈	3 ⁹ / ₁₆
5312	3/4	15	33	16.6	12 ⁵ / ₈	15/16	1 ¹ / ₈	11/16	11	4 ³ / ₈	2 ³ / ₁₆	2 ³ / ₁₆	5 ¹⁵ / ₁₆	2 ³ / ₈	3 ⁹ / ₁₆
5313	3/4	20	33	17.3	12 ⁵ / ₈	15/16	1 ¹ / ₈	11/16	11	4 ³ / ₈	2 ³ / ₁₆	2 ³ / ₁₆	5 ¹⁵ / ₁₆	2 ³ / ₈	3 ⁹ / ₁₆
5328	1	5	44	15.0	12 ⁵ / ₈	15/16	1 ¹ / ₈	11/16	11	4 ³ / ₈	2 ³ / ₁₆	2 ³ / ₁₆	5 ¹⁵ / ₁₆	2 ³ / ₈	3 ⁹ / ₁₆
5315	1 ¹ / ₂	5	51	27.0	14 ³ / ₁₆	1 ¹ / ₈	1 ¹ / ₄	13/16	16 ¹ / ₄	4 ³ / ₈	2 ³ / ₈	2 ³ / ₈	6 ⁷ / ₈	3	3 ¹⁵ / ₁₆
5316	1 ¹ / ₂	10	51	31.4	14 ³ / ₁₆	1 ¹ / ₈	1 ¹ / ₄	13/16	16 ¹ / ₄	4 ³ / ₈	2 ³ / ₈	2 ³ / ₈	6 ⁷ / ₈	3	3 ¹⁵ / ₁₆
5317	1 ¹ / ₂	15	51	35.8	14 ³ / ₁₆	1 ¹ / ₈	1 ¹ / ₄	13/16	16 ¹ / ₄	4 ³ / ₈	2 ³ / ₈	2 ³ / ₈	6 ⁷ / ₈	3	3 ¹⁵ / ₁₆
5318	1 ¹ / ₂	20	51	40.2	14 ³ / ₁₆	1 ¹ / ₈	1 ¹ / ₄	13/16	16 ¹ / ₄	4 ³ / ₈	2 ³ / ₈	2 ³ / ₈	6 ⁷ / ₈	3	3 ¹⁵ / ₁₆
5329	2	5	68	27.0	14 ¹³ / ₁₆	1 ¹ / ₈	1 ¹ / ₄	13/16	16 ¹ / ₄	4 ³ / ₈	2 ³ / ₈	2 ³ / ₈	6 ⁷ / ₈	3	3 ¹⁵ / ₁₆
5320	3	5	77	45.0	18 ¹¹ / ₁₆	1 ¹³ / ₁₆	1 ⁹ / ₁₆	1 ¹ / ₄	16 ¹ / ₄	7 ¹ / ₂	3 ³ / ₈	4 ³ / ₁₆	7 ⁷ / ₈	3 ³ / ₈	4 ⁹ / ₁₆
5321	3	10	77	52.3	18 ¹¹ / ₁₆	1 ¹³ / ₁₆	1 ⁹ / ₁₆	1 ¹ / ₄	16 ¹ / ₄	7 ¹ / ₂	3 ³ / ₈	4 ³ / ₁₆	7 ⁷ / ₈	3 ³ / ₈	4 ⁹ / ₁₆

*** ⚠ WARNING**

Overloading and improper use can result in injury.

To avoid injury:

- Do not exceed working load limit, load rating capacity
- Do not use to lift people or loads over people.
- use only alloy chain for overhead lifting.
- Read and follow all instructions.



Upper Shipyard hook

Capacity (tons)	Product code	Net Wt. (lbs.)
1 ¹ / ₂	3315WLP	2.9
3	3303WLP	4.9



Lower Shipyard hook

1 ¹ / ₂	3415WLP	2.1
3	3403WLP	4.8

Puller



The CM Puller is designed for heavy-duty construction and industrial applications. Used to pull, lift, drag or stretch, it features:

- Tough aluminum alloy construction and powder coat finish
- Weatherproof for outdoor service
- Simple construction with fewer parts for ease of maintenance and lower inventories
- Hoistaloy hardened steel link type load chain for strength, long wear life and flexibility
- Weatherized Weston-type automatic braking system for positive load control
- Easy, one-hand operation and control — only 58 pounds of pull required for 3/4 ton model capacity
- Forged upper and lower hooks with latches standard
- Free wheeling for fast and easy attachment to load
- Upper and lower Latchlok hooks available for all capacities
- Optional Load Limiter protection device stops transmission of lever forces protecting against dangerous overload
- Optional anchor sling simplifies attachment to allow anchor hook to swivel in tight space applications (3/4 & 1 1/2 ton units only)
- Optional Load Sentry warns of overload condition
- Optional zinc-plated chain available
- Unlimited lift
- Lifetime warranty
- Metric rated
- Made in U.S.A.



Optional Load Limiter



Optional anchor sling (3/4 and 1 1/2 ton)

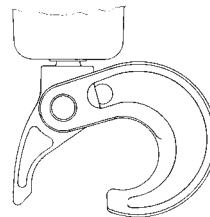

Latchlok type hook



3/4 ton

Puller specifications - standard unit

Rated capacity* (tons)	Product code	Standard lift† (ft.)	Pull to lift full loads (lbs.)	Minimum distance between hooks (in.)	Lever length (in.)	Reeving	Hook throat openings (in.)	Approx. shipping weight (lbs.)
3/4	4043	5	58	10 3/4	21 1/4	1	1 1/32	16
1 1/2	4045	5	89	14 1/4	21 1/4	1	1 1/8	26
3	4047	5	95	16 15/16	21 1/4	2	1 7/32	38
6	4050	5	96	21 3/8	21 1/4	4	1 3/4	73

† Can be supplied with lifts longer than 5 feet

Optional kits

Rated capacity* (tons)	Load Limiter		Load Sentry kit			Anchor sling kit	
	Product code	Approx. shipping weight (lbs.)	Product code	Lever length (in.)	Approx. shipping weight (lbs.)	Product code	Approx. shipping weight (lbs.)
3/4	4190	8 1/4	4096	23 3/4	4 1/2	4071	2
1 1/2	4191	8 1/4	4098	23 3/4	4 1/2	4072	4 3/4
3	4191	8 1/4	4098	23 3/4	4 1/2	—	—
6	4191	8 1/4	4098	23 3/4	4 1/2	—	—

Short handle puller

- Easy one-hand operation
- Lever pull range is 45 to 62 pounds to lift full load
- Handle that rotates 360°, making it easy to operate in any position and in small spaces
- Tough yet lightweight aluminum construction and powder coat finish
- Hoistaloy hardened steel load chain for strength, long wear life and flexibility
- Free chaining for fast, easy attachment to load
- Forged upper and lower hooks with latches
- Simple construction with fewer parts for ease of maintenance
- Optional Load Limiter device protects against overload
- Lifetime warranty
- Made in U.S.A.



Specifications - Short handle puller

Rated capacity* (tons)	Product code	Standard lift (ft.)	Pull to lift full loads (lbs.)	Minimum distance between hooks (in.)	Lever length (in.)	Reeving	Hook throat openings (in.)	Approx. shipping weight (lbs.)
3/4	7300P	5	45	12 1/4	12	1	1 1/32	16
1 1/2	7320P	5	55	14 3/4	16 3/4	1	1 1/8	27
3	7330P	5	62	17 5/8	16 3/4	2	1 3/16	40

Specifications - Short handle puller without chain

Rated capacity* (tons)	Product code	Approx. shipping weight (lbs.)
3/4	7301P	12
1 1/2	7321P	21
3	7331P	28



Optional Load Limiter



Optional upper Latchlok Hook 3/4 - 1 1/2 ton

Optional kits

	Product code	Approx. shipping weight (lbs.)	Rated capacity* (tons)
Load Limiter	7310P	1	3/4
	7311P	2	1 1/2-3
Anchor Sling	7309P	2	3/4
	7312P	3	1 1/2
Latchlok Hook	1001	2	3/4
	upper 1003	2	1 1/2
	1004	3	3
	lower 1001	2	3/4
	1003	2	1 1/2
	1005	3	3



Optional upper Latchlok Hook 3 ton



Optional anchor sling

Rigger lever operated hoist



Designed for moderate commercial applications, this lightweight, compact tool stores easily and features:

- Flexible, non-binding CM load chain
- Forged upper and lower hooks with latches standard
- Free-wheeling chain for fast attachment
- Clover leaf chain guides and stripper seat chain in liftwheel reduce chance of jamming
- Unlimited lift by ordering any length chain
- Ratchet, driving pawl and holding pawl for load control
- One lever used to change from lifting to lowering and back to lifting
- Easy maintenance
- One-year warranty
- Metric rated
- Made in U.S.A.

* **WARNING**

Overloading and improper use can result in injury.

To avoid injury:

- Do not exceed working load limit, load rating capacity
- Do not use to lift people or loads over people.
- use only alloy chain for overhead lifting.
- Read and follow all instructions.

Specifications

Rated capacity* (tons)	Product code	Standard lift† (ft.)	Reeving	Pull to lift full load (lbs.)	Minimum distance between hooks (in.)	Lever length (in.)	Hook throat openings (in.)	Shipping weight (lbs.)
3/4	2301	5	1	98	10 ³ / ₄	15 ⁵ / ₈	1 ¹ / ₃₂	8 ³ / ₄
1 ¹ / ₂	2302	5	2	98	12 ¹ / ₂	15 ⁵ / ₈	1 ¹ / ₃₂	13 ³ / ₄

† Can be supplied with lifts longer than 5 feet

Wire rope lever hoists



Engineered for Reliable Operation

- Handle Designed for Overload Protection—Handle bends to warn of hazardous condition and prevent dangerous overload.
- Hooks with Hook Latches—360° swiveling hooks equipped with latches for positive load engagement.
- Meets ANSI Standard B30.21.
- Tested to 125% of Capacity.
- Made in U.S.A.

Portable and Durable

- Lightweight and Rugged—Special cast aluminum alloy housings.
- Heavy Duty Cable—Utilizes preformed and galvanized 7 x 19 (133 strand) extra flexible aircraft cable.
- Corrosion Resistant—All stainless steel springs and shafts.
- Reduced Wear—All rotating shafts are mounted on bronze bushings.

Easy to Operate

- Self-storing Cable Drum—Provides compact operation.
- Fast Cable Take-up—Winding wheel provided for quick take-up or positioning of cable.
- Easy Load Positioning—Utilizes a double interlocking pawl system for precise load adjustment.
- Positive Load Holding in All Environments—Provided by double interlocking pawl mechanism.
- Open Construction—Allows for easy cleaning and inspection.

Special Model Features

- All models are available with Bullard-type hooks.
- CM430CDPA equipped with oversized slip hooks— ideal for opening and closing boxcar doors.

* **WARNING**

Overloading and improper use can result in injury.

To avoid injury:

- Do not exceed working load limit, load rating capacity
- Do not use to lift people or loads over people.
- use only alloy chain for overhead lifting.
- Read and follow all instructions.

Single & Double Line • 1000 - 4000 Lbs.

Specifications		SINGLE LINE			DOUBLE LINE			Cable Dia. x Length (In.) (Ft.)	Ship Weight (Lbs.)
Product Code	Model	Capacity (Lbs.)	Lift (Ft.)	Hook to Hook (Min.) (In.)	Capacity (Lbs.)	Lift (Ft.)	Hook to Hook (Min.) (in.)		
04601W	115SA	1000	13 ³ / ₄	19	—	—	—	3/16 x 16	8 ³ / ₄
04602W	115DA	1000	13 ¹ / ₂	21	2000	6 ¹ / ₂	27	3/16 x 16	10 ¹ / ₂
04610W	505NA	1500	13	21	—	—	—	1/4 x 15	9 ¹ / ₂
04611W	202WNA	1500	12 ¹ / ₂	21	3000	6	27	1/4 x 15	11 ¹ / ₂
04620W	434WNA	1500	21 ¹ / ₂	22 ¹ / ₂	3000	10 ¹ / ₄	28 ¹ / ₂	1/4 x 24	13 ¹ / ₄
04621W	430CDPA	1500	21 ¹ / ₂	25	3000	10 ¹ / ₄	33 ¹ / ₂	1/4 x 24	16
04631W	404WNA	2000	12 ¹ / ₂	22 ¹ / ₂	4000	6	28 ¹ / ₂	9/32 x 15	13 ¹ / ₂

GT Series

Grip and pull wire rope lever tool

The GT Grip and Pull Lever Tool is a rugged and portable unit designed for heavy duty pulling, rigging, dragging, and stretching applications. Its ability to grip and pull heavy loads over long distances specially suit this tool for use in the construction and transportation industries, as well as hundreds of other industrial applications.

- **CAPACITIES & REACH** - Rated loads from 1 to 3 tons, with standard wire rope length of 32 feet on 1 and 3 ton models; 65 feet on 2 ton model.
- **SMOOTH OPERATION / LOW WEAR** - The large surface area of the the dual clamping jaws provides an evenly distributed grip on the wire rope for smooth operation and low wear.
- **POSITIVE LOAD CONTROL** - The greater the force of the pull, the greater the clamping force of the jaws. Unique jaw design prevents damage to the wire rope.
- **LIMITLESS WIRE ROPE TRAVEL** - Versatility for use over long distances.
- **DURABILITY** - Lightweight and compact design for portability, yet built tough for long life and trouble free service.
- **OVERLOAD PROTECTION** - Easily replaceable, shear pin design to protect against dangerous overloads.
- **TELESCOPIC HANDLE** - Enhances portability and ease of operation.
- **MINIMAL MAINTENANCE** - Periodic cleaning, inspection, and lubrication is all that is required.
- **LIFETIME WARRANTY** - Lifetime warranty against defects in materials and workmanship. Refer to full CM Warranty Statement for details.



Specifications

Rated Capacity (Tons)	Model Number	Product Code	Standard Wire Rope Length (Ft.)	Wire Rope Diam. (In.)	Lever Length Extended (In.)	Lever Length Retracted (In.)	Rope Advance † (In.)	Overall Dimensions (In.)	Net Weight* (Lb.)	Net Weight** (Lb.)
1	GT-1300-32	0013	32	3/16	29.1	21.3	1.30	19.7 x 9.1 x 4.0	35	18
2	GT-2000-65	0020	65	7/16	29.1	21.3	1.45	24.8 x 13.0 x 5.9	79	40
3	GT-3500-32	0035	32	5/8	29.1	21.3	0.78	28.6 x 12.8 x 7.0	94	66

† Per Full Stroke at Rated Load
* Wire Rope Included
** Less Wire Rope

CM Series 632 close radius trolley



With revolutionary advances, this shorter, more compact trolley is 50% lighter than competitive trolleys, yet every bit as tough.

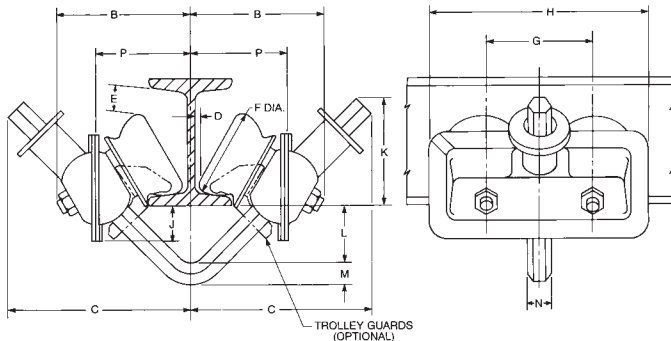

- Negotiates radius curves as tight as 7 to 10 inches
- Made of highest quality rolled steel
- Unique double row, ball bearing wheel design for greater wear capacity
- Larger V-bars available for wider flange adjustment
- For low headroom applications
- Bearings prepacked with lifetime lubricant
- Exclusive Dial-Fit collar quickly adapts trolley to wide range of beams and patented rails
- Dust covers shield and protect bearings
- Trolleys available for larger beams, rails or tracks; contact CM
- Cast iron trolley guards available (except for 3 ton)
- Lifetime warranty
- Made in U.S.A.

Clearance dimensions (in.)

Dimension	Rated capacity* (tons)			
	1/4 & 1/2	1	1 1/2 & 2	3
Min. radius curve (in.)	7	7	10	10
B	4 1/4	4 3/8	5 5/8	6 3/16
C	5 7/8	6	7 1/2	8 1/16
D	3/16	3/16	3/8	1 1/16
E	1 3/16	1 3/16	2 3/16	4 1/16
F	2 3/4	2 3/4	3 1/2	3 1/2
G	3 3/8	3 3/8	4 1/2	4 1/2
H	7	7	9	9
J	1 1/8	1 1/8	1 1/2	1 5/8
K	3 3/8	3 1/2	4 3/8	4 13/16
L	1 13/16	1 5/8	2	2 5/8
M	1 1/16	7/8	1 1/8	1 1/8
N	7/8	1	1 1/4	1 1/4
P	3	3 1/8	3 7/8	4 15/16

Dimensions given are for minimum S-beam and will vary with larger beams.

* ⚠ WARNING

Overloading and improper use can result in injury.

To avoid injury:

- Do not exceed working load limit, load rating capacity
- Do not use to lift people or loads over people.
- use only alloy chain for overhead lifting.
- Read and follow all instructions.

Specifications

Rated capacity* (tons)	Product code	Adj. for standard S-beams					
		Depth of beam (in.)	Flange width (in.)	Tread diameter (in.)	Net weight (lbs.)	Shipping weight (lbs.)	Minimum radius curve (in.)
1/4-1/2	3222	4-12	2 5/8-5 1/16	2 3/4	9	10	7
1	3224	4-12	2 5/8-5 1/16	2 3/4	10	12	7
1 1/2-2	3226	6-15	3 3/8-5 5/8	3 1/2	23	25	10
3	3230	8-18	4-6 1/4	3 1/2	29	33	10

All capacities can be supplied for S-beams larger than listed and also for wide flange beams, rails or tracks with approximately equivalent flange widths.

Series 84A plain or geared trolley

Manufactured for heavy duty, industrial grade applications. CM Series 84A trolleys feature fully sealed, precision bearings, heavy duty side frames and fully machined wheel tread for superior performance and *long life* — with *minimal maintenance*.



- Available in capacities from 1/4 through 25 ton with 30 through 50 ton trolleys available as tandem construction.
- Lifetime lubricated, precision ball bearings on trolleys through 3 ton capacity. Trolleys with capacities 4 tons and greater are equipped with eight sealed, Timken tapered roller bearings and grease fittings.
- Heavy rolled steel side frames extend beyond the wheels to provide these trolleys with superior strength, rigidity and added protection for the trackwheels. Units with capacities from 1/4 through 12 tons employ universal wheel treads for use on flat or tapered beam flanges. Units with capacities from 16 through 25 tons operate on American Standard I-beams with tapered flanges. For patented track, consult factory.
- Trolley wheels are fully machined from alloy cast iron and hardened for high strength and long life.
- Alloy steel axles and equalizer pins are heat treated for maximum strength and wear life.
- Geared versions have fully machined trackwheel gears and incorporate a swinging chain guide which keeps the hand chain aligned and free from jamming.
- Available to fit a broad range of wider flange beams and patented track applications not listed - contact factory.
- Made in the USA
- Spark resistant models available — add suffix “SR”

Specifications

Product code	Rated capacity (tons)	Beam height (in.)	Flange width (in.)	Minimum radius curve (in.)	Approximate net weight	
					Plain	† Geared
1641-0025	1/4	4 - 12	2.66 - 5.00	20	23	38
1641-0050	1/2	4 - 12	2.66 - 5.00	20	23	38
1641-0100	1	5 - 12	3.00 - 6.00	24	43	62
1641-0150	1 1/2	5 - 12	3.00 - 6.00	24	45	65
1641-0200	2	6 - 18	3.33 - 6.25	30	67	90
1641-0300	3	6 - 18	3.33 - 6.25	30	70	93
1641-0400	4	8 - 24	4.00 - 7.00	36	155	184
1641-0500	5	8 - 24	4.00 - 7.00	36	160	188
1641-0600	6	8 - 24	4.00 - 7.00	36	160	188
1641-0800	8	10 - 24	4.62 - 8.00	60	300	347
1641-1000	10	10 - 24	4.62 - 8.00	60	310	360
1641-1200	12	10 - 24	4.62 - 8.00	60	310	360
1631-1600	16	18 - 24	6.00 - 8.00	96	800	895
1631-2000	20	18 - 24	6.00 - 8.00	96	845	955
1631-2500	25	18 - 24	6.00 - 8.00	120	1045	1200

For wide flange beam adaptation, patented track or for beams larger than standard - contact factory.

† Weight less hand chain. **8 Ft. standard zinc plated hand chain drop on geared trolley.** Specify curve on order.

Series 84A plain or geared trolley-Specifications

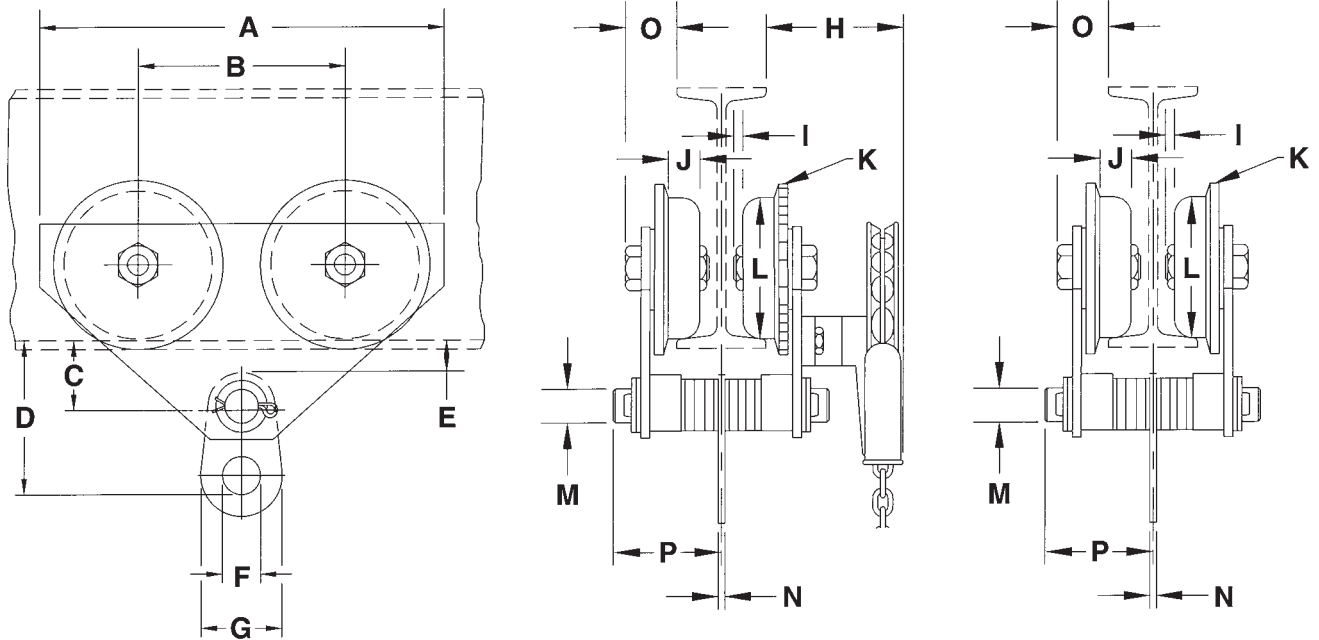

Cap. (tons)	A	B	C	D	E	F	G	H	I	J	K	L	M	N	O	P
1/4	11 1/2	6	1 7/8	4 7/8	7/8	1 3/4	2 3/4	6	—	7/8	4	2 7/8	1	1/4	2	4 1/8
1/2	11 1/2	6	1 7/8	4 7/8	7/8	1 3/4	2 3/4	6	—	7/8	4	2 7/8	1	1/4	2	4 1/8
1	13 1/4	6 3/4	2 1/4	5 3/8	1	1 3/4	3	6 1/8	—	1 1/8	5	3 3/4	1 1/4	1/4	13 3/4	4 3/4
1 1/2	13 1/4	6 3/4	2 1/4	5 3/8	1	2	3 1/4	6 1/8	—	1 1/8	5	3 3/4	1 1/4	3/8	13 3/4	4 3/4
2	15 5/8	7 5/8	2 5/8	6 3/4	1 1/8	2 1/8	3 5/8	6 1/8	—	1 1/8	6	4 1/2	1 1/2	3/8	2 1/8	5 1/4
3	15 5/8	7 5/8	2 5/8	6 7/8	1 1/8	2 1/4	4	6 1/8	—	1 1/8	6	4 1/2	1 1/2	1/2	2 1/8	5 1/4
4	18 3/4	8 1/2	3 1/4	8 3/8	1 1/4	2 3/4	4 3/4	8 1/8	1/8	1 3/8	8	6 3/8	2	5/8	2 5/8	6 1/8
5	18 3/4	8 1/2	3 1/4	8 5/8	1 1/4	3	5 1/2	8 1/8	1/8	1 3/8	8	6 3/8	2	5/8	2 5/8	6 1/8
6	18 3/4	8 1/2	3 1/4	8 5/8	1 1/4	3	5 1/2	8 1/8	1/8	1 3/8	8	6 3/8	2	5/8	2 5/8	6 1/8
8	23 5/8	10 5/8	3 7/8	10 5/8	1 3/8	3 1/2	6 1/2	9	1/8	1 11/16	10	8 1/4	2 1/2	3/4	3 1/4	6 7/8
10	23 5/8	10 5/8	3 7/8	11 1/8	1 3/8	4 1/2	8	9	1/8	1 11/16	10	8 1/4	2 1/2	1	3 1/4	6 7/8
12	23 5/8	10 5/8	3 7/8	11 1/8	1 3/8	4 1/2	8	9	1/8	1 11/16	10	8 1/4	2 1/2	1	3 1/4	6 7/8
16	28 1/4	14	5 7/8	15 1/4	2 1/2	4	9	14 1/2	5/16	2	13 1/2	11 3/4	3 1/4	1 1/2	7	8
20	28 1/4	14	5 7/8	16 5/8	2 1/2	4	10	14 1/2	5/16	2	13 1/2	11 3/4	3 1/4	13/4	7	8 1/4
25	28 1/4	14	5 7/8	16 3/4	2 1/8	4	10	14 1/2	5/16	2	13 1/2	11 3/4	3 1/4	13/4	7	8 1/4

Notes: All dimensions are in inches.
 Wheels with convex treads are standard on all capacities.
 20, 25, 30 and 40 ton trolleys can be furnished in tandem construction - Dimensions for 30 through 50 ton units available upon request.
 Dimensions shown are for minimum beam size and will vary proportionately for larger beams.

Series 80 trolley for hook mounted hoists push type

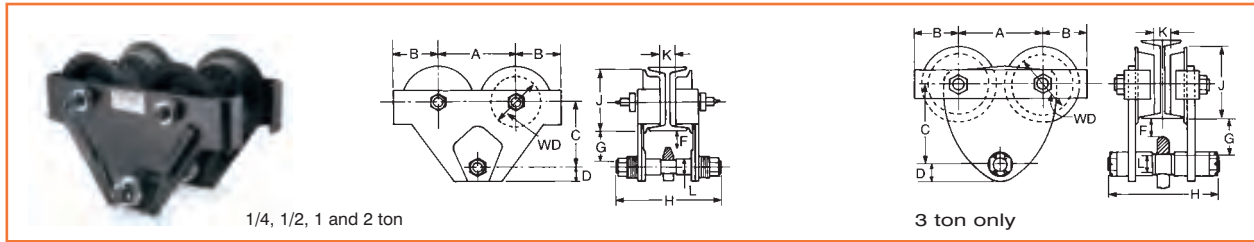

1/4, 1/2, 1 and 2 ton

3 ton only

Hook Suspension

- Available in 1/4 ton to 3 ton capacities
- Can be used with any hook suspended hoist
- Runs on either American Standard or wide flange shapes.

- Trolley side frames feature all steel construction for strength and durability
- Steel wheels with hardened treads and ball bearings provide easy and long life
- Hand geared trolleys are ideal for accurate positioning and long lifts

Rigid Mount

- For use with lug suspended hoists such as the CM AirStar or AirStar 6
- Available in 1/2 to 3 ton

- Offers minimum headroom
- Push, hand geared, or motorized models available
- On hand geared models, anti-tilt rollers eliminate the tilting of the trolley when operating with a light load
- Features a lifetime warranty and are made in U.S.A.

Clearance dimensions (in.)

Rated capacity* (tons)	Product code	A	B	C	D	WD	† Min. F	G	H	J	** Min. K	L
1/4	80	4 ³ / ₈	2 ¹³ / ₁₆	4 ¹ / ₈	1	3 ¹ / ₈	3/4	1 ¹³ / ₁₆	7 ⁹ / ₁₆	3 ¹⁵ / ₁₆	1 ¹ / ₁₆	7/8
	80WFA	4 ³ / ₈	2 ¹³ / ₁₆	4 ¹ / ₈	1	3 ¹ / ₈	3/4	1 ¹³ / ₁₆	9 ⁷ / ₈	3 ¹⁵ / ₁₆	3 ¹ / ₁₆	7/8
1/2	81	4 ³ / ₈	2 ¹³ / ₁₆	4 ¹ / ₈	1	3 ¹ / ₈	3/4	1 ¹³ / ₁₆	7 ⁹ / ₁₆	3 ¹⁵ / ₁₆	1 ¹ / ₁₆	7/8
	81WFA	4 ³ / ₈	2 ¹³ / ₁₆	4 ¹ / ₈	1	3 ¹ / ₈	3/4	1 ¹³ / ₁₆	9 ⁷ / ₈	3 ¹⁵ / ₁₆	3 ¹ / ₁₆	7/8
1	82	6 ¹ / ₈	3 ⁹ / ₁₆	5 ¹ / ₈	1 ¹ / ₈	4	1 ¹ / ₁₆	2 ¹ / ₄	8 ¹ / ₄	4 ⁷ / ₈	1 ³ / ₁₆	1
	82WFA	6 ¹ / ₈	3 ⁹ / ₁₆	5 ¹ / ₈	1 ¹ / ₈	4	1	2 ³ / ₁₆	10 ³ / ₈	4 ⁷ / ₈	2 ¹³ / ₁₆	1
	82WFB	6 ¹ / ₈	3 ⁹ / ₁₆	5 ¹ / ₈	1 ¹ / ₈	4	1	2 ³ / ₁₆	12 ³ / ₈	4 ⁷ / ₈	4 ¹³ / ₁₆	1
2	83	6 ⁷ / ₈	3 ¹³ / ₁₆	5 ³ / ₄	1 ⁵ / ₁₆	4 ¹⁵ / ₁₆	1 ³ / ₁₆	2 ¹ / ₄	8 ³ / ₄	—	3/4	1 ¹ / ₈
	83WFA	6 ⁷ / ₈	3 ¹³ / ₁₆	5 ³ / ₄	1 ⁵ / ₁₆	4 ¹⁵ / ₁₆	3/4	2 ³ / ₁₆	10 ³ / ₄	—	3 ³ / ₈	1 ¹ / ₄
	83WFB	6 ⁷ / ₈	3 ¹³ / ₁₆	5 ³ / ₄	1 ⁵ / ₁₆	4 ¹⁵ / ₁₆	3/4	2 ³ / ₁₆	12 ³ / ₄	—	5 ³ / ₈	1 ¹ / ₄
3	905480	6 ⁷ / ₈	4 ³ / ₈	1 ⁵ / ₈	4 ¹⁵ / ₁₆	4 ¹⁵ / ₁₆	9/16	2 ³ / ₈	12	6	1 ¹ / ₄	1 ¹³ / ₃₂
	905481	6 ⁷ / ₈	4 ³ / ₈	1 ⁵ / ₈	4 ¹⁵ / ₁₆	4 ¹⁵ / ₁₆	9/16	2 ³ / ₈	14 ³ / ₄	6	4 ¹ / ₄	1 ¹³ / ₃₂
	905482	6 ⁷ / ₈	4 ³ / ₈	1 ⁵ / ₈	4 ¹⁵ / ₁₆	4 ¹⁵ / ₁₆	9/16	2 ³ / ₈	17 ⁵ / ₈	6	7	1 ¹³ / ₃₂

† Clearance dimensions "F" and "G" are based on the largest beam on which trolley will operate. Dimension increases slightly for each smaller beam size.

**Dimension "K" occurs on smallest beam size only. On larger beams it is increased by the difference in flange width.

Specifications

Rated capacity* (tons)	Product code	Min. beam depth (in.)	Min. radius curve	Adj. flange width (in.)	Approx. net weight (lbs.)
1/4	80	4	2'-6"	2 ⁵ / ₈ -4 ⁵ / ₈	13
	80WFA	4	2'-6"	5-7	14
1/2	81	4	2'-6"	2 ⁵ / ₈ -4 ⁵ / ₈	13
	81WFA	4	2'-6"	5-7	14
1	82	5	3'-0"	3-5	25
	82WFA	5	3'-0"	5-7	26
	82WFB	5	3'-0"	7-9	27
2	83	6	4'-0"	3 ³ / ₈ -6	35
	83WFA	6	4'-0"	6-8	36
	83WFB	6	4'-0"	8-10	37
3	905480	6	4'-0"	3 ³ / ₈ -6	41
	905481	6	4'-0"	6 ¹ / ₈ -8 ⁷ / ₈	43
	905482	6	4'-0"	9-11	44

Series 80 trolley for hook mounted hoists hand geared

- Made in U.S.A.

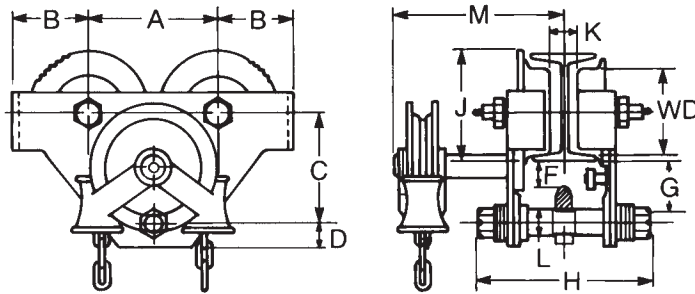

1, 2 and 3 ton

Clearance dimensions (in.)

Rated capacity* (tons)	Product code	A	B	C	D	WD	† Min. F	G	H	J	** Min. K	L	M
1	82G	6 ¹ / ₈	3 ⁹ / ₁₆	5 ¹ / ₈	1 ¹ / ₈	4	1 ¹ / ₁₆	2 ¹ / ₄	8 ¹ / ₄	4 ⁷ / ₈	1 ³ / ₁₆	1	—
1	82GWFA	6 ¹ / ₈	3 ⁹ / ₁₆	5 ¹ / ₈	1 ¹ / ₈	4	1	2 ¹³ / ₁₆	10 ³ / ₈	5 ¹ / ₂	2 ¹³ / ₁₆	1	11 ¹⁵ / ₁₆
1	82GWFB	6 ¹ / ₈	3 ⁹ / ₁₆	5 ¹ / ₈	1 ¹ / ₈	4	1	2 ¹³ / ₁₆	12 ³ / ₈	5 ¹ / ₂	4 ¹³ / ₁₆	1	11 ¹⁵ / ₁₆
2	83G	6 ⁷ / ₈	3 ¹³ / ₁₆	5 ³ / ₄	1 ⁵ / ₈	4 ¹⁵ / ₁₆	1 ³ / ₁₆	2 ¹ / ₄	8 ³ / ₄	6 ⁵ / ₁₆	3 ⁴ / ₈	1 ¹ / ₈	10 ⁹ / ₁₆
2	83GWFA	6 ⁷ / ₈	3 ¹³ / ₁₆	5 ³ / ₄	1 ⁵ / ₈	4 ¹⁵ / ₁₆	3 ⁴ / ₈	2 ³ / ₁₆	10 ³ / ₄	6 ⁵ / ₁₆	3 ³ / ₈	1 ¹ / ₄	11 ⁷ / ₈
2	83GWFB	6 ⁷ / ₈	3 ¹³ / ₁₆	5 ³ / ₄	1 ⁵ / ₈	4 ¹⁵ / ₁₆	3 ⁴ / ₈	2 ³ / ₁₆	12 ³ / ₄	6 ⁵ / ₁₆	5 ³ / ₈	1 ¹ / ₄	12 ⁷ / ₁₆
3	905490	6 ⁷ / ₈	4 ³ / ₁₆	6	1 ⁵ / ₈	4 ¹⁵ / ₁₆	9 ¹ / ₁₆	2 ³ / ₈	12	6 ⁵ / ₁₆	1 ¹ / ₄	1 ¹³ / ₃₂	8 ⁵ / ₁₆
3	905491	6 ⁷ / ₈	4 ³ / ₁₆	6	1 ⁵ / ₈	4 ¹⁵ / ₁₆	9 ¹ / ₁₆	2 ³ / ₈	14 ³ / ₄	6 ⁵ / ₁₆	4 ¹ / ₄	1 ¹³ / ₃₂	19 ¹³ / ₁₆
3	905492	6 ⁷ / ₈	4 ³ / ₁₆	6	1 ⁵ / ₈	4 ¹⁵ / ₁₆	9 ¹ / ₁₆	2 ³ / ₈	17 ⁵ / ₈	6 ⁵ / ₁₆	7	1 ¹³ / ₃₂	21 ³ / ₁₆

†Clearance dimensions “F” and “G” are based on the largest beam on which trolley will operate. Dimension increases slightly for each smaller beam size.

**Dimension “K” occurs on smallest beam size only. On larger beams it is increased by the difference in flange width.

Specifications

Rated capacity* (tons)	Product code	Min. beam depth (in.)	Min. radius curve	Adj. flange width (in.)	Approx. net weight (lbs.)
1	82G	5	3'-0"	3-5	25
1	82GWFA	5	3'-0"	5-7	26
1	82GWFB	5	3'-0"	7-9	27
2	83G	6	4'-0"	3 ³ / ₈ -6	35
2	83GWFA	6	4'-0"	6-8	36
2	83GWFB	6	4'-0"	8-10	37
3	905490	6	4'-0"	3 ³ / ₈ -6	41
3	905491	6	4'-0"	6 ¹ / ₈ -8 ⁷ / ₈	43
3	905492	6	4'-0"	9-11	44

CM Series 633 wide range trolley

Simple, rugged, built for trouble-free service and ease of operation across a wide range of beam applications. Series 633 features:

- Rugged steel side plates formed to include bumpers and trolley guards
- Frames connected by steel equalizer pin, secured by two nuts on each side
- Universal tread flanged trackwheels equipped with shielded ball bearings
- Easy rolling on American standard shapes, wide flange shapes or patented rail
- Hardened wheels and axles for added strength and durability
- Spacer washers can be shifted inside or outside for easy adjustment to wide range of beams
- To be used with hook suspended hoist
- Suspension plate for easy attachment is standard
- Bearings prepacked with lifetime lubricant
- One-year warranty
- Imported

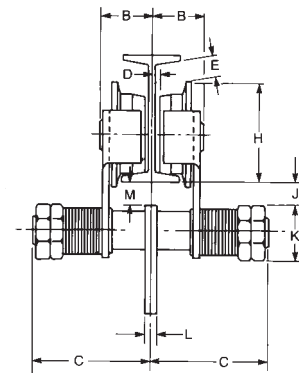
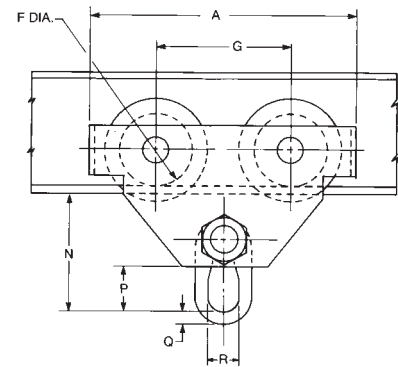

Clearance dimensions (in.)

Dimension	Rated capacity* (tons)				
	1/2	1	2	3	5
Min. radius curve (in.)	35	35	59	71	94
A	8 1/2	10 13/16	12 7/32	14 13/16	18 1/8
B**	2 5/32	2 13/32	2 1 1/16	3 1/16	3 2 1/32
C	5 1/16	6 9/16	6 25/32	7 13/32	8
D**	1/16	7/16	13/32	1/2	9/16
E**	-1/4	1 1/32	25/32	1 7/16	2 3/16
F	2 9/32	3 15/32	3 15/16	5 1/8	6 1/8
G	4	4 7/8	5 1/2	6 9/16	7 7/8
H**	3	4 1 1/32	4 29/32	6 1/8	7 9/32
J**	1 1/32	1 1/32	25/32	1 3/16	2 1/8
K	1 3/4	2 3/32	2 1/2	3 13/32	3 13/32
L	1/2	1/2	5/8	5/8	13/16
M**	15/16	3 1/32	5/16	15/16	1 7/16
N**	4 3/32	5 1/16	5 13/16	7 7/16	9 15/16
P	1 7/32	1 3/4	2 5/32	2 9/16	3 23/32
Q	1 9/32	1 9/32	1 3/16	1 3/8	1 25/32
R	3 1/32	1 5/32	1 5/8	1 3 1/32	2 9/16

**Dimensions given are for minimum S-beam and will vary with larger beams.

Specifications

Rated capacity* (tons)	Product code	Adj. for standard S-beams			Net weight (lbs.)	Shipping weight (lbs.)
		Depth of beam (in.)	Flange width (in.)	Tread diameter (in.)		
1/2	3302	3-15	2 1/2-5 5/8	2 9/32	15	17
1	3304	5-24	3-8	3 1 5/32	34	36
2	3306	6-24	3 5/8-8	3 1 5/16	50	53
3	3307	8-24	4-8	5 1/8	95	100
5	3309	10-24	4 5/8-8	6 1/8	172	175

RailStar motor driven trolley

- Fits wide range of beam sizes for maximum versatility
- Universal use with any hook suspended single speed hoists that are equipped with reversing contactor
- Steel plate side frames
- Steel spur gearing for optimum strength and smooth operation
- Durable hardened cast iron track-wheels that operate on standard S-beams or flat flanged beams
- Lifetime lubricated double row ball bearings for high efficiency, low maintenance
- Cast iron control enclosure
- Four-button control station included for operating single speed hoist. Drop proportioned to 20' lift
- 115 volt control circuit
- Trolley guards standard
- One-year warranty
- Metric rated
- Imported

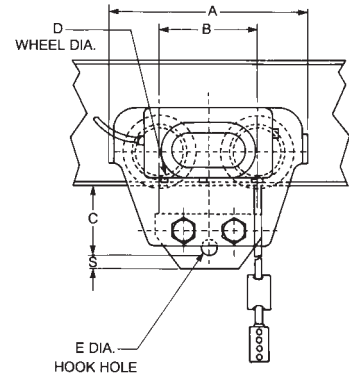

Clearance dimensions (in.)

Dimension	Rated capacity* (tons)	
	1/8 - 2	3
A	12 ³ / ₄	14 ¹ / ₈
B	6 ³ / ₈	6 ³ / ₄
C**	4 ¹³ / ₁₆	5 ¹ / ₄
D	3 ⁹ / ₁₆	3 ¹⁵ / ₁₆
E	2 ⁹ / ₁₆	2 ¹⁵ / ₁₆
F**	4 ³ / ₄	5 ³ / ₁₆
G**	6	6 ⁵ / ₁₆
H**	17 ft.	17 ft.
J	7 ¹ / ₂	9 ¹⁵ / ₁₆
K	4 ¹ / ₈	4 ¹¹ / ₁₆
SINGLE PHASE L	12 ³ / ₄	15 ³ / ₁₆
THREE PHASE L	11 ⁷ / ₁₆	13 ⁷ / ₈
M**	1 ¹ / ₂	2 ¹⁵ / ₁₆
N**	3/8	3/4
P**	1 ⁷ / ₁₆	1 ⁹ / ₁₆
Q**	5 ¹ / ₈	5 ⁷ / ₈
R	1/2	3/4
S	1 ¹ / ₁₆	1 ¹ / ₁₆
T**	8 ⁷ / ₈	9 ⁹ / ₁₆

**Dimensions given are for minimum S-beam and will vary with larger beams.

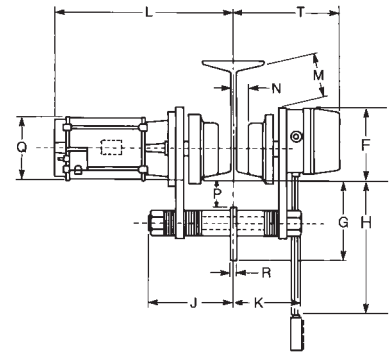

*** ⚠ WARNING**

Overloading and improper use can result in injury.

To avoid injury:

- Do not exceed working load limit, load rating capacity
- Do not use to lift people or loads over people.
- use only alloy chain for overhead lifting.
- Read and follow all instructions.

Tractor drive

Power tractor drives push-type hoists, trolleys and underhung cranes. Easy installation without removing or modifying existing equipment. This drive also features:

- Compact design
- Capacities up to 5 tons available in 230/460-3-60 operation
- Monorail trolley track or twin unit synchronized drives available
- Direct drive with right angle worm gear reducer
- Enclosed aluminum housing for lubrication of gears and bearings
- Steel plate construction with tie-rods for easy adjustment
- Squirrel cage motor with permanently lubricated bearings
- Fully machined trolley wheels with universal tread operate on tapered or flat flange beams
- Adjusts to standard I-beams or flat flange beams up to 8 inches wide
- Standard magnetic reversing contactor with mechanical interlock inside NEMA 1 enclosure
- One-year warranty
- Made in U.S.A.

Options

- 575 volt 3 phase 60 hertz operation
- 2, 4, 6 & 8 button push-button station
- Additional push-button cable length (10' standard)
- NEMA 12, 4 or 4X control enclosures
- Motor brake
- Soft start (recommended for speeds above 70 F.P.M.)
- Two speed or variable controls
- Transformer for 115 volt control power
- Tow bar
- For other beams, options or custom designs, consult factory

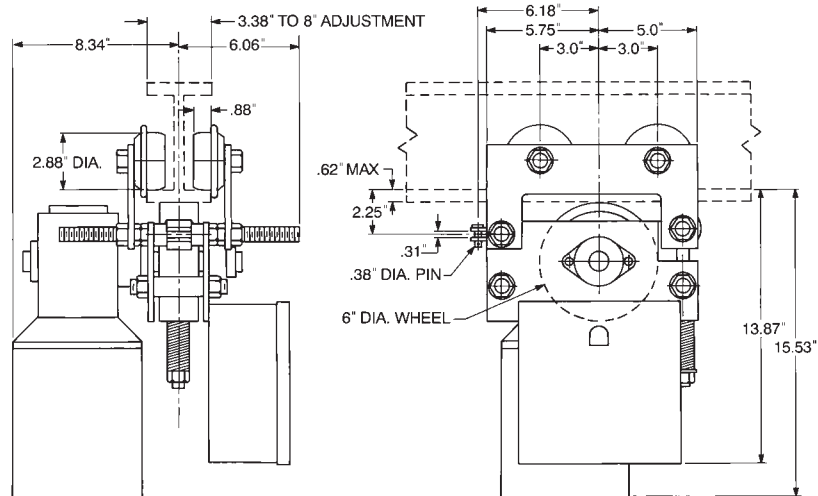

Rated capacity* (tons)	Product code	Speed (F.P.M.)	Std. beam size (in.)	Min. radius curve (in.)	Max. flange thickness (in.)	Approx. shipping wt. (lbs.)
1	TD 235	35	3.38-8	36	.62	110
1	TD 255	55	3.38-8	36	.62	110
1	TD 270	70	3.38-8	36	.62	110
1	TD 2105	105	3.38-8	36	.62	110
1½	TD 335	35	3.38-8	36	.62	110
1½	TD 355	55	3.38-8	36	.62	110
1½	TD 370	70	3.38-8	36	.62	110
1½	TD 3105	105	3.38-8	36	.62	110
2½	TD 535	35	3.38-8	36	.62	110
2½	TD 555	55	3.38-8	36	.62	110
2½	TD 570	70	3.38-8	36	.62	110
3	TD 635	35	3.38-8	36	.62	110
3	TD 655	55	3.38-8	36	.62	110
5	TD 1035	35	3.38-8	36	.62	110

Hoist Test Stand - 12 Ton Capacity

The Value - Priced, Hydraulic Hand Operated Test Stand — Tests Hoist Capacity to 12 Tons

The Value-Priced CM Test Stand is specially designed for the testing of hoisting equipment as required by the applicable sections of ASME Code B30.16. Unlike other test stands on the market that weigh thousands of pounds, the CM Value-Priced Test Stand weighs only 496 pounds. Portability for on-site testing becomes more practical. Fewer wearing parts provide superior performance.

- Hand operated hydraulic pump eliminates the need for electrical power.
- Capable of applying test loads up to 12 tons.
- Compact, self-contained design for portability and on-site testing.
- Eliminates the need for cumbersome test weights.
- Capable of both static and dynamic testing.
- Tests the function of overload devices.
- Rugged steel frame construction for strength and durability.
- High quality, high strength, hydraulic cylinder made from chromium-molybdenum steel, heat treated for long life and chrome plated for added protection.
- Two-stage, quick action hand pump for ease of operation.
- Fine adjustment pressure valve for accurate load testing.
- Large pressure gauge for easy reading.
- Made in USA

Technical data

Hydraulic Cylinder (hollow)

Type	• Single acting, spring return
Maximum pulling force	• 12 tons @ 5800 p.s.i.
Stroke	• 6 in.
System pressure	• 0 - 5800 p.s.i.
Center hole diameter	• .87 in.

Hydraulic Hand Pump

System pressure	• 0 - 6090 p.s.i.
Reservoir	• 1.47 pints
Valve	• Two-stage, fine adjustment pressure preset
Gauge	• Glycerin filled - 3.94 in. dia.

Frame	• Mounting holes in base for permanent mount
-------	--

Total Weight	• 496 lbs.
--------------	------------



12 Ton Test Stand
Product Code 1200

Hoist test stand-Specifications

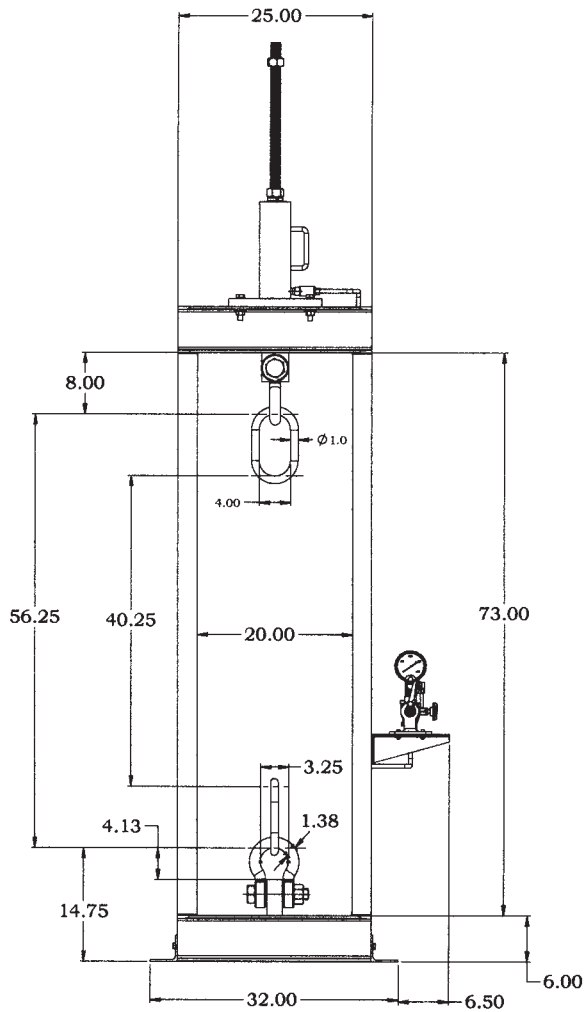

Front View

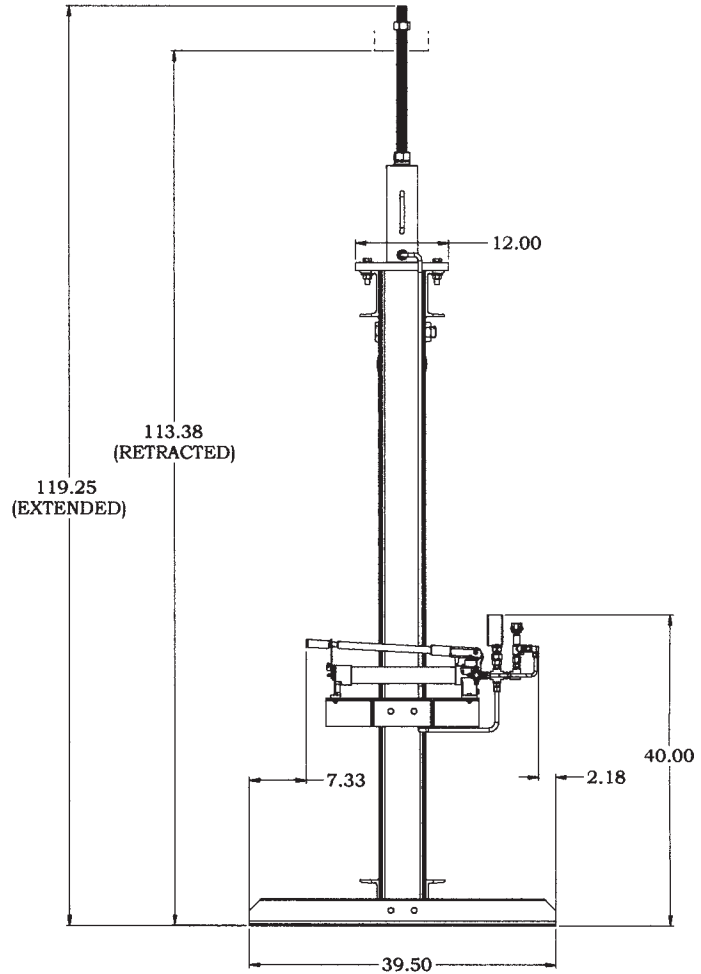

Side View

All Dimensions In Inches

▲ WARNING
Overloading and improper use can result in injury.
To avoid injury:
<ul style="list-style-type: none"> • Do not exceed maximum pulling force of 12 tons • Read and follow all instructions.

Items to Consider When Selecting Powered Hoists and Trolleys

- Capacity (lbs., tons, or kg.)
- Lift (ft. or m)
- Lift speed (ft. / min.) (m / min.)
- Lifting medium (chain or wire rope)
- Power (electric, air, etc.)
- Power cord length
- Push button cord length
- Type of suspension
- Type of trolley (manual, powered, plain, geared)
- Headroom requirements
- Beam size and type
- Trolley speed
- Trolley brake requirements
- Power Supply voltage
- Control voltage
- Single, two speed or variable speed
- Duty cycle requirements
- Special electrification needs
- Abnormal operating conditions
- Chain container

CM[®] **Industrial Products**
Division of Columbus McKinnon Corporation



From beam to hoist to below the hook – THE choice for top-performing products is CM Complete Lifting Systems. Users in a wide-range of industries trust CM products for durability, reliability, ease of use and low maintenance. Whether it is lifting steel coils by the ton or delicately positioning switchboards, the breadth of products that comprise CM Complete Lifting Systems is unsurpassed.

Although the broad product offering is one aspect of CM Complete Lifting Systems that provides separation from the competition, many additional services stand out:

- A global network of authorized distributors provides inventory, technical support, service after the sale, and consultation regarding specific needs.
- A thoroughly trained, knowledgeable sales force provides expertise on applications, regulations, training requirements, and product features and benefits.
- Manufacturing facilities where testing exceeds the standards outlined by industry regulations.
- Training programs dedicated specifically to rigging products or broad-based to cover all aspects of lifting and positioning.
- The ONLY manufacturer of rigging products that is also a LEADER in the manufacturing and marketing of hoists, overhead cranes, and related products.
- More than 130 years of experience in providing products and programs that exceed the expectations of customers.
- Many of the most recognized names in the material handling industry.



Electric and air operated chain hoists provide the core of CM Complete Lifting Systems. Over the years, the Lodestar electric chain hoist has been the standard to which other hoists aim to emulate. The popular Lodestar is used in wide-ranging environments from nuclear facilities to rock concerts. Overall capacities for CM electric chain hoists range from 1/4 tons to 15 tons. Air hoists such as the Airstar provide unsurpassed spotting capabilities and have working load limits from 1/4 tons to 7-1/2 tons. Air manipulators are available in both chain and wire rope styles and are used for lifting and positioning activities in the 250-600 lbs. range. If heavy-duty lifting with a wire rope hoist is preferred, the Apollo or Polaris tackle loads weighing up to 15 tons. Manual hoists, including lever tools, position, pull, and lift loads in construction, maintenance, and repair activities.



Integral parts of CM Complete Lifting Systems, items such as chain slings, shackles, masterlinks, and hooks are manufactured in various styles and configurations. Herc-Alloy 1000 chain offers a lightweight alternative to traditional Grade 80 chain for overhead lifting, while Lodelok hooks offer ease of use and maximum security. Specially made from proprietary Micro-Alloy material, Super Strong Shackles provide superior working limits than any carbon shackles on the market. Hammerlok couplers with the innovative Pat-Lok retainer make the assembly of mechanical chain slings a snap. Hoist rings rotate and pivot while offering superior attachment points while lifting.



The LodeRail enclosed track system is available as a stand-alone device or as a ceiling mounted system. Easy to install, the LodeRail provides a convenient, versatile anchor point for mounting hoists and manipulators. Maximum capacity is 2 tons, and units can be built to meet the exact requirements of the production line or workstation.



Jib cranes can be manufactured in a wide range of capacities and styles including wall mount and 360 degree pivoting. Trolleys for use with jib cranes or steel beams fit flanges up to 8 inches. Overhead crane components round out the offering.



C-Hooks, Spreader beams, Crane Forks, and related below-the hook accessories are available as standard units or made to order for specific applications. Popular C-hooks handle items such as steel coils and paper rolls and can be supplied to fit into confined work environments.



For lifting steel sheets, aluminum plates, and related items, Camlok clamps provide the necessary stability and mobility. The C Series is excellent for lifting and turning over plates in one smooth movement, while special clamps such as gentle grip, wide mouth, and multi-rail handling are manufactured for specific applications.



Low headroom and spark-resistant hoists provide peace of mind in sensitive environments. Additionally, Chester hoists can be "made to order" based on the exact needs of the user. Manual and Powered trolleys can be manufactured to fit a wide range of I-beam, wide flange, or patented track systems.



While known primarily for load binders and forestry tools, Dixie Industries has expanded into a true engineering forge shop. Concentrating on producing products based on unique customer needs, Dixie produces specialty hooks and related items for OEM's and users in a wide array of industries.



The Steerman Load Moving System offers low rolling resistance due to its specially formulated nylon wheels. Steerman's unique design with integral front rotating plate permits easy movement around corners. Capacities from 5 tons to 100 tons.



INDUSTRIAL MAGZA DISTRIBUIDOR AUTORIZADO MEX (55) 53 63 23 31 QRO (442) 1 95 72 60 MTY (81) 83 54 10 18 ventas@industrialmagza.com

CM Complete Lifting Systems – the ONE name for ALL material handling needs.

www.cmindustrial.com • 800-888-0985

Stock No. HTSP-5 SS 10M