

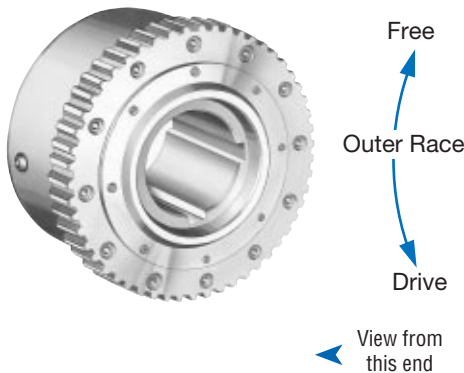

Overrunning, Backstopping Ball Bearing Supported Sprag, High Torque Drawworks Clutches



Left Hand rotation shown.
(Right Hand opposite.)

Specify direction of rotation when ordering.

Drawworks clutches are designed for use with Hydromatic® brakes on drilling rigs. They are available over a range of torque capacities and provide reliable performance in original equipment or as a replacement for type C2 and type A clutches.

Model FSD-27 Sprag

Use with Hydromatic brakes having 6" or smaller shafts.

- Interchangeable with National Supply Company's model 703250-C2

Model FSD-65 Sprag

Use with Hydromatic brakes having 7.5" shafts.

- Directly interchangeable with other type A clutches

Model FSD-125 Sprag

Use with Hydromatic brakes having 7.5" shafts, can be substituted for type A clutches.

- For use with type A spider and sleeve

Model FSD-300 Sprag

Use with Hydromatic brakes having 9" shafts.

- Provides five times the torque capacity than type A clutches

The Model HBG series are designed for use on Hydro-dynamic Brakes on drilling rigs, using Ramp & Roller Technology which offers better availability.

Model HBG-27MA Ramp & Roller

Use with Hydromatic brakes having 6.5" or smaller straight or tapered shafts.

- Interchangeable with National type C clutches

Model HBG-63MA Ramp & Roller

Use with Hydromatic brakes having 7.5" straight and tapered shafts.

- Interchangeable with National type A clutches

Model HBG-135MA Ramp & Roller

Use with Hydromatic brakes having 7.5" tapered and larger shafts.

- Interchangeable with National Type D-1

FSD and HBG clutches are shipped from the factory with Automatic Transmission fluid (ATF).

Specifications/spline data

| Size | Torque Capacity lb.ft. (Nm) | Resistance after run-in lb.ft. (Nm) | Shipping Weight lb. (kg) | No. of Teeth | Pressure Pitch | Angle | Pitch Diameter in. (mm) | Major Dia. in. (mm) | Minor Dia. in. (mm) |
|------------|-----------------------------------|-------------------------------------------|--------------------------------|--------------|----------------|-------|-------------------------------|----------------------------------|---------------------------|
| FSD-27 | 27,000 (36,720) | 10 (14) | 185 (84) | 40 | 3/6 | 30° | 13.333 (338.66) | 13.597/13.592 (345.36/345.23) | 12.929 (328.40) |
| FSD-65 | 65,000 (88,400) | 25 (35) | 508 (231) | 53 | 3/6 | 30° | 17.666 (448.72) | 17.929/17.915 (455.39/455.04) | 17.263 (438.48) |
| FSD-125 | 125,000 (170,000) | 30 (40) | 615 (279.5) | 53 | 3/6 | 30° | 17.666 (448.72) | 17.929/17.915 (455.39/455.04) | 17.263 (438.48) |
| FSD-300 | 300,000 (408,000) | 75 (100) | 1,650 (750) | 110 | 4/5 | 20° | 27.500 (698.50) | 27.900/27.890 (708.66/708.40) | 27.000 (685.80) |
| HBG-27MA | 27,000 (36,720) | — | 265 (131) | 40 | 3/6 | 30° | 13.333 (338.66) | 13.597/13.592 (345.36/345.23) | 12.929 (328.40) |
| HBG-63MA | 63,000 (85,680) | — | 515 (255) | 53 | 3/6 | 30° | 17.666 (448.72) | 17.929/17.915 (455.39/455.04) | 17.263 (438.48) |
| HBG-135 MA | 135,000 (183,600) | — | 1,100 (544) | 68 | 3/6 | 30° | 22.666 (575.72) | 22.929/22.924 (582.40/582.27) | 22.217 (564.31) |

**FSD-27
HBG-27MA**

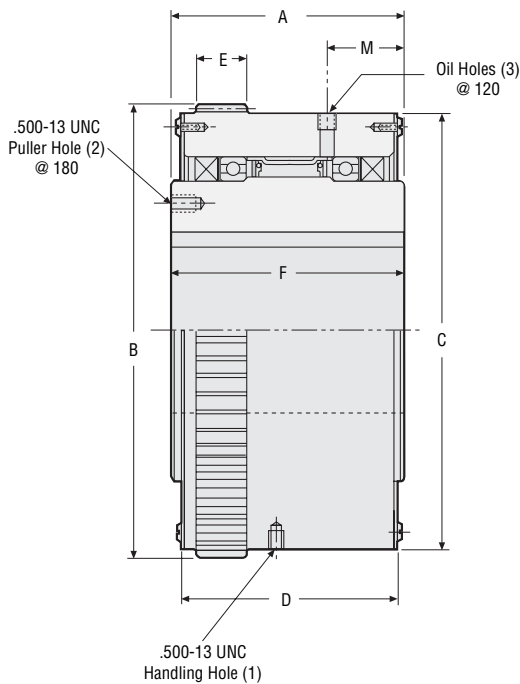

**FSD-65, -125, -300
HBG-63MA, - 135MA**

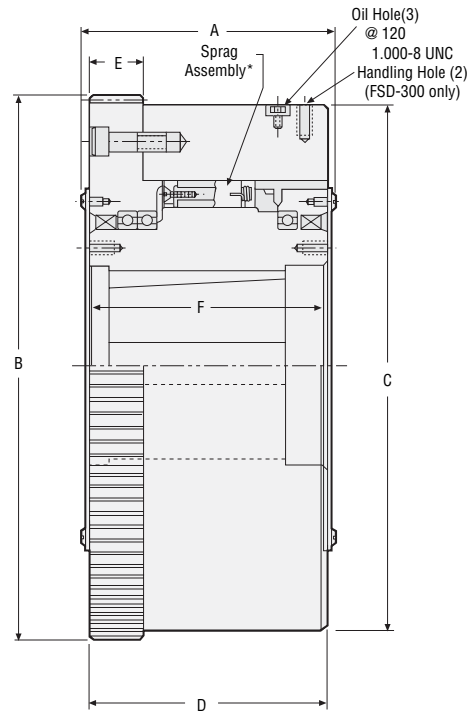

* FSD-125 has two sprag assemblies.

Standard bore sizes and keyseats inches (mm)

| Size | Bore Diameter | Taper per ft. (per M) | Keyseat |
|----------|--------------------------------------------------------------------|-----------------------|--------------------------------------------|
| 27 | 6.00 (152.40) | None | 1.25 x .83 (31.70 x 21.08) |
| 63, 65 | 7.473/7.476 (189.81/189.89) | 1.250" (3.175) | 1.500/1.503 x .89 (38.10/38.18 x 22.60) |
| 125, 135 | 7.473/7.476 (189.81/189.89) | 1.250" (3.175) | 1.500/1.503 x .89 (38.10/38.18 x 22.60) |
| 300 | 7.473/7.476 (189.81/189.89) 8.9745/8.9775 (227.95/228.03) | 1.250" (3.175) | 2.500/2.503 x .84 (63.50/63.57 x 21.34) |

Dimensions inches (mm)

| Size | A | B | C | D | E | F |
|-----------|-------------------|----------------------------------|----------------------------------|-------------------|-----------------|-------------------|
| FSD-27 | 7.00 (177.80) | 13.597/13.592 (345.36/345.23) | 12.896/12.866 (327.55/326.79) | 6.43 (163.32) | 1.50 (38.10) | 7.00 (177.80) |
| FSD-65 | 10.31 (261.87) | 17.929/17.915 (455.39/455.04) | 17.230/17.200 (437.64/436.88) | 9.81 (249.17) | 2.40 (60.96) | 9.72 (246.88) |
| FSD-125 | 13.13 (333.50) | 17.929/17.915 (455.39/455.04) | 17.230/17.200 (437.64/436.88) | 12.63 (320.80) | 2.40 (60.96) | 12.49 (317.25) |
| FSD-300 | 12.62 (320.54) | 27.900/27.890 (708.66/708.40) | 26.980/26.960 (685.29/684.78) | 12.12 (307.84) | 2.69 (68.32) | 12.06 (306.32) |
| HBG-27MA | 7.00 (177.80) | 13.597/13.592 (345.36/345.23) | 13.03 (330.96) | 7.00 (177.80) | 1.50 (38.10) | 7.00 (177.80) |
| HBG-63MA | 8.75 (222.25) | 17.929/17.915 (455.39/455.04) | 17.34 (440.44) | 8.75 (222.25) | 1.88 (47.75) | 8.75 (222.25) |
| HBG-135MA | 10.00 (254.00) | 22.929/22.924 (582.40/582.27) | 22.09 (561.09) | 10.00 (254.00) | 2.50 (63.50) | 10.00 (254.00) |



Overrunning, Inline, Standby and Creep Drive Operation Ball Bearing Supported, Sprag Clutches

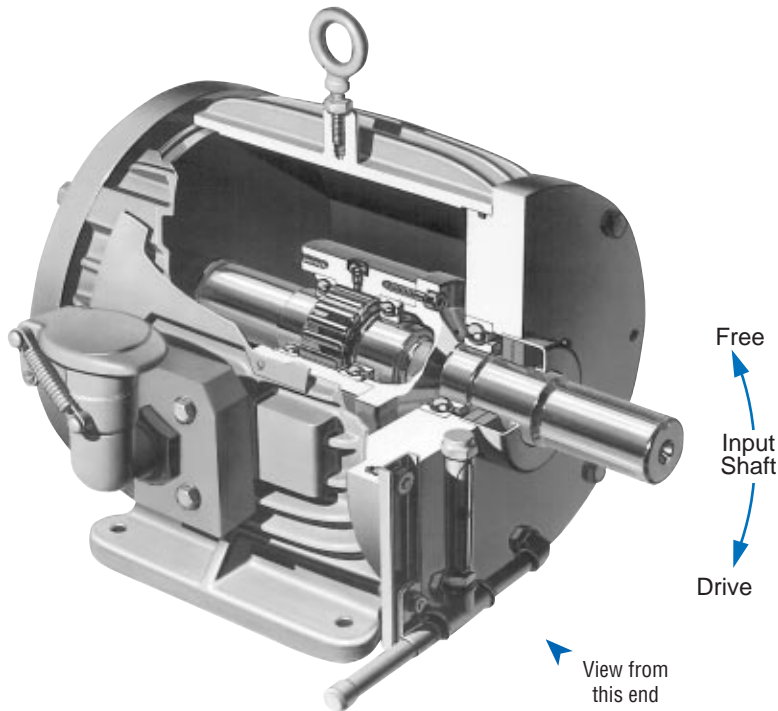

Right Hand rotation shown. (Left Hand opposite.)
Specify direction of rotation when ordering.

Continuous drive units are intended for use in continuous overrunning applications where the system cannot be shut down for maintenance and for applications in extremely harsh and dusty environments such as coal handling systems.

A CDU consists of an FSO overrunning, sprag clutch installed in a foot-mounted housing which encloses a generous supply of oil. The large oil volume along with the high dissipation capability of the finned housing permits extended service periods between oil changes. An oil sight gauge is mounted on each CDU for quick and easy monitoring of the oil level. Oil can be added without stopping the machine. The entire unit is sealed. Grease barrier seals minimize contamination and wear of the oil seals in environments with abrasive material.

The overrunning clutch internal to the CDU-500 through 1051 is oil dipped at the factory but *must be filled to the proper level before operation.*

For further information write for Instruction and Maintenance Bulletin No. A-3038. Contact Formsprag application engineering department on indirect drive applications.

Sprag assemblies available

All CDUs have ultra-hard Formchrome® sprags which provide extra-long life, maximum wear resistance, and lower maintenance costs. Formchrome sprags, exclusive with Formsprag, are made by diffusing chromium into the surface of a hardened high carbon steel to form a chromium-carbide alloy. Models 500, 600 and 700 are equipped with PCE (Positive Continuous Engagement) sprags which are designed to overcome the effects of torsional vibration and high transient torque. C/T (Centrifugal Throwout) sprags, which lift off of the inner race, thereby eliminating overrunning wear, are available in all models.

Features

PCE Sprags

Help prevent clutch damage due to transient overloads or torsional vibrations

Formchrome Sprags with 70 Rc Hardness

Maximum wear life for extended clutch service

Large Oil Reservoir

Minimum maintenance (increased lubrication capacity)

Grease Barrier Seals

Protects oil seals from dusty and abrasive conditions providing extended seal life

Oil Fill and Drain Ports

Ease of maintenance

Breather

Pressure equalization without affecting oil seals

Foot Mounted Unit

Stand alone unit provides for easy access, installation and removal without disturbing equipment

Optional Centrifugal Throwout (C/T) Sprag Design

Provides extended clutch life by eliminating rubbing contact of sprags during overrunning portion of duty cycle

Oil Sight Gauge

Provides a convenient method for checking oil level with CDU in operation

Applications

The CDUs in this catalog are designed for inline drives only. Applications for these self-contained foot-mounted continuous drive units are creep drives, turning gear drives, dual drives, energy recovery drives, and standby drives. C/T may be used in installations such as creep drives and turning gear drives where the drive speed is well below the overrunning speed.

For CDU installations requiring offset drives, contact Formsprag.

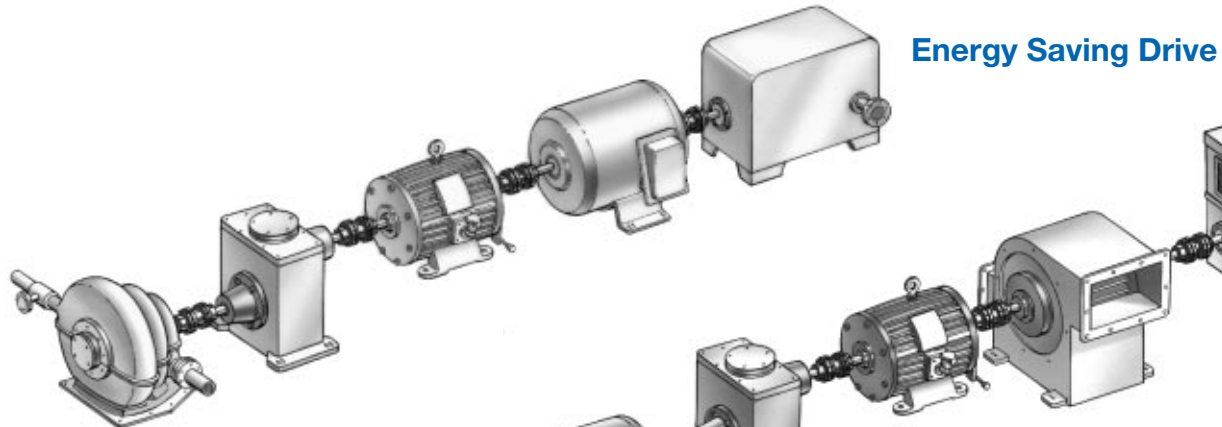
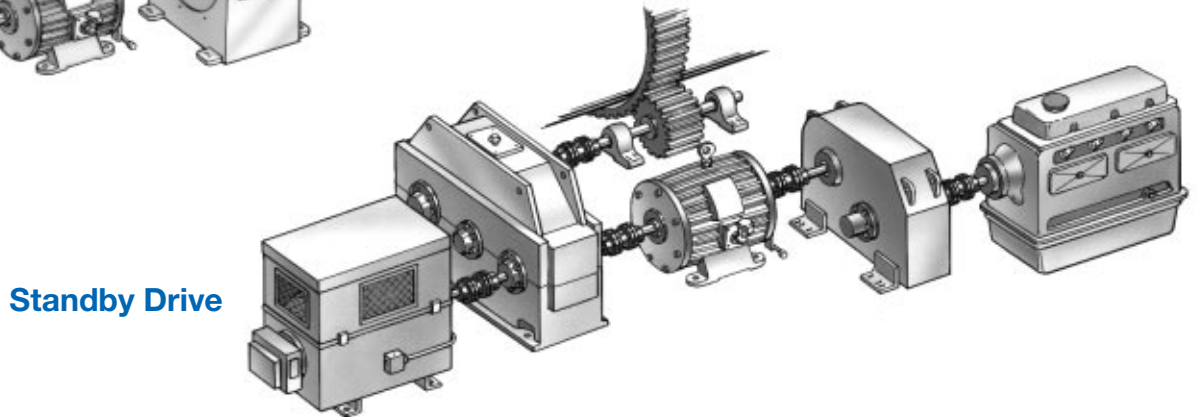
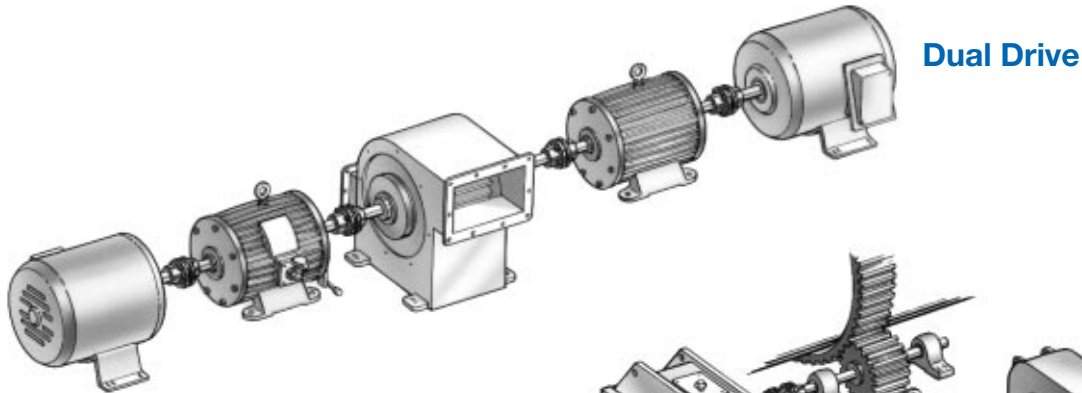
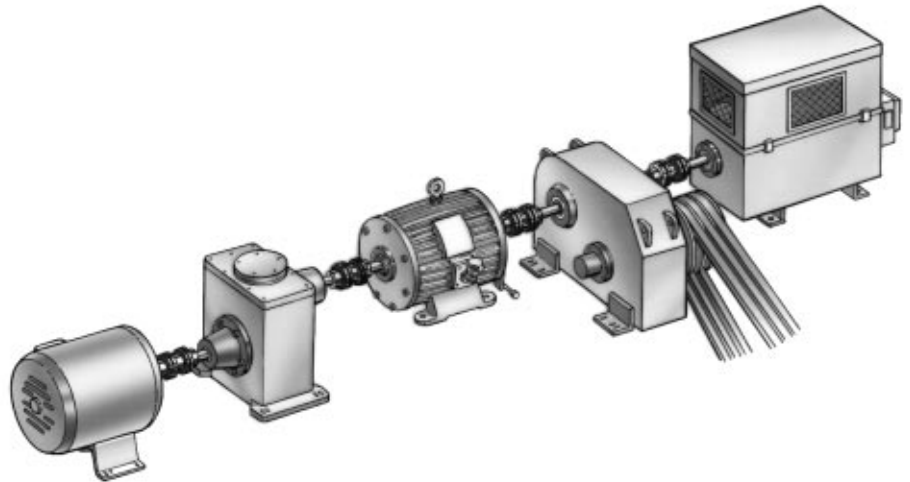

Special Purpose Clutches

CDU



MEX (55) 53 63 23 31 MTY (81) 83 54 10 18
 QRO (442) 1 95 72 60 ventas@industrialmagza.com

Specifications

| Size | Torque Capacity lb.ft. (Nm) | Maximum RPM | | | | | Resistance after run-in lb.ft. (Nm) | Shipping Weight lb. (kg) |
|------|-----------------------------------|----------------|-------------|---------|----------------|-------------|----------------------------------------------|-----------------------------------|
| | | Standard Model | | Driving | C/T Model | | | |
| | | Driving | Overrunning | | Sprag lift-off | Overrunning | | |
| 500 | 1,175 (1593) | 3,600 | 3,600 | 1,000 | 1,200 | 3,600 | .45 (.61) | 125 (57) |
| 600 | 2,250 (3051) | 3,600 | 3,600 | 1,000 | 1,200 | 3,600 | .90 (1.22) | 135 (61) |
| 700 | 5,000 (6780) | 2,000 | 2,000 | 800 | 1,000 | 2,000 | 2.13 (2.89) | 529 (240) |
| 750 | 7,000 (9492) | 1,800 | 1,800 | 650 | 800 | 1,800 | 7.50 (10.16) | 570 (259) |
| 800 | 13,000 (17628) | 1,500 | 1,500 | 525 | 675 | 1,500 | 10.50 (14.23) | 836 (389) |
| 900 | 18,000 (24408) | 1,350 | 1,350 | 500 | 650 | 1,350 | 12.50 (16.94) | 890 (404) |
| 1027 | 27,000 (36600) | 1,100 | 1,100 | 375 | 475 | 1,100 | 20.00 (27.10) | 1,289 (584) |
| 1051 | 45,000 (61010) | 1,100 | 1,100 | 375 | 475 | 1,100 | 24.00 (32.52) | 1,339 (607) |

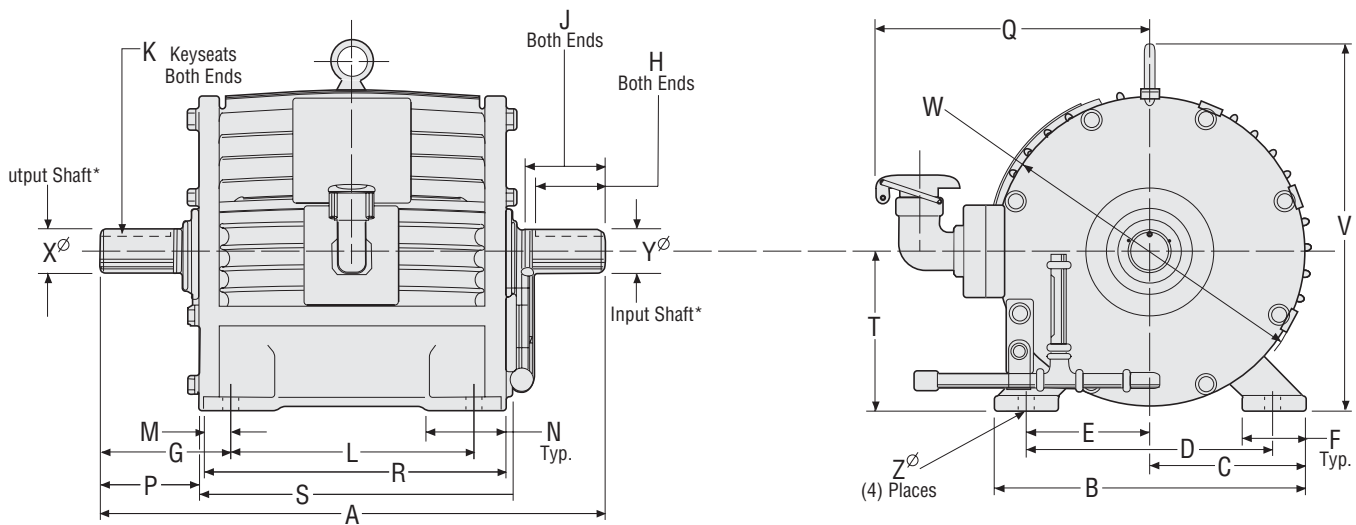

*For C/T models, the input and output shaft diameters are reversed.



Dimensions inches (mm)

| Size | A | B | C | D | E | F | G | L | M | N | P | Q | R | S | T | V | W | Z |
|------|--------------------|-------------------|-------------------|-------------------|------------------|------------------|-------------------|-------------------|-----------------|------------------|-------------------|-------------------|-------------------|-------------------|-------------------|-------------------|-------------------|-----------------|
| 500 | 18.00 (427.20) | 10.50 (266.70) | 5.25 (133.35) | 8.50 (215.90) | 4.25 (107.95) | 2.00 (50.80) | 5.50 (139.70) | 7.00 (177.80) | .75 (19.05) | 4.25 (107.95) | 4.19 (106.43) | 9.38 (238.25) | 8.50 (215.90) | 10.62 (269.75) | 5.25 (133.35) | 13.38 (339.85) | 10.75 (273.05) | .406 (10.31) |
| 600 | 19.25 (488.95) | 10.50 (266.70) | 5.25 (133.35) | 8.50 (215.90) | 4.25 (107.95) | 2.00 (50.80) | 6.12 (155.45) | 7.00 (177.80) | .75 (19.05) | 4.25 (107.95) | 5.38 (136.65) | 9.38 (238.25) | 8.50 (215.90) | 10.62 (269.75) | 5.25 (133.35) | 13.38 (339.85) | 10.75 (273.05) | .406 (10.31) |
| 700 | 26.75 (679.45) | 15.75 (400.05) | 7.88 (200.15) | 12.50 (317.50) | 6.25 (158.75) | 3.25 (82.55) | 7.38 (187.45) | 12.00 (304.80) | 1.50 (38.10) | 3.12 (79.25) | 5.78 (146.81) | 12.25 (311.15) | 15.00 (381.00) | 15.19 (385.83) | 8.00 (203.20) | 19.00 (482.60) | 16.38 (416.05) | .656 (16.66) |
| 750 | 28.25 (717.55) | 15.75 (400.05) | 7.88 (200.15) | 12.50 (317.50) | 6.25 (158.75) | 3.25 (82.55) | 8.13 (206.50) | 12.00 (304.80) | 1.50 (38.10) | 3.12 (79.25) | 6.53 (166.81) | 12.25 (311.15) | 15.00 (381.00) | 15.19 (385.83) | 8.00 (203.20) | 19.00 (482.60) | 16.38 (416.05) | .656 (16.66) |
| 800 | 34.00 (863.60) | 19.75 (501.65) | 9.88 (250.95) | 16.00 (406.40) | 8.00 (203.20) | 3.75 (95.25) | 10.12 (257.05) | 13.75 (349.25) | 1.50 (38.10) | 3.50 (88.90) | 8.12 (206.25) | 14.12 (358.65) | 16.75 (425.45) | 17.75 (450.85) | 10.00 (254.00) | 23.25 (590.55) | 20.50 (520.70) | .812 (20.63) |
| 900 | 36.00 (914.50) | 19.75 (501.65) | 9.88 (250.95) | 16.00 (406.40) | 8.00 (203.20) | 3.75 (95.25) | 11.12 (282.45) | 13.75 (349.25) | 1.50 (38.10) | 3.50 (88.90) | 9.12 (231.65) | 14.12 (358.65) | 16.75 (425.45) | 17.75 (450.85) | 10.00 (254.00) | 23.25 (590.55) | 20.50 (520.70) | .812 (20.63) |
| 1027 | 41.00 (1041.40) | 22.00 (558.80) | 11.00 (279.40) | 18.00 (427.20) | 9.00 (228.60) | 4.00 (101.60) | 12.25 (311.15) | 16.50 (419.10) | 1.50 (38.10) | 4.00 (101.60) | 11.00 (279.40) | 15.00 (381.00) | 19.50 (495.30) | 19.00 (482.60) | 11.00 (279.40) | 26.19 (665.23) | 22.25 (565.15) | .812 (20.63) |
| 1051 | 41.00 (1041.40) | 22.00 (558.80) | 11.00 (279.40) | 18.00 (427.20) | 9.00 (228.60) | 4.00 (101.60) | 12.25 (311.15) | 16.50 (419.10) | 1.50 (38.10) | 4.00 (101.60) | 11.00 (279.40) | 15.00 (381.00) | 19.50 (495.30) | 19.00 (482.60) | 11.00 (279.40) | 26.19 (665.23) | 22.25 (565.15) | .812 (20.63) |

| Size | X* Output Shaft Dia. | Y* Input Shaft Dia. | Both Ends | | |
|------|--------------------------------|--------------------------------|--------------------------------|--------------------------------|-------------------------------------|
| | | | K Keyseats | J Usable Shaft Length | H Effective Keyseat Length |
| 500 | 1.437/1.436 (36.49/36.47) | 1.500/1.499 (38.10/38.07) | 3/8 x 3/16 (9.53 x 4.76) | 2.75 (69.85) | 2.50 (63.50) |
| 600 | 1.687/1.686 (42.85/42.82) | 1.750/1.749 (44.45/44.42) | 3/8 x 3/16 (9.53 x 4.76) | 3.38 (85.85) | 3.00 (76.20) |
| 700 | 3.000/2.999 (76.20/76.17) | 3.062/3.061 (77.77/77.75) | 3/4 x 3/8 (19.05 x 9.65) | 4.50 (114.30) | 4.00 (101.60) |
| 750 | 3.000/2.999 (76.20/76.17) | 3.062/3.061 (77.77/77.75) | 3/4 x 3/8 (19.05 x 9.65) | 5.38 (136.65) | 4.75 (120.65) |
| 800 | 3.937/3.936 (100.00/99.97) | 4.000/3.999 (101.60/101.57) | 1 x 1/2 (25.40 x 12.70) | 6.25 (158.75) | 5.00 (127.00) |
| 900 | 3.937/3.936 (100.00/99.97) | 4.000/3.999 (101.60/101.57) | 1 x 1/2 (25.40 x 12.70) | 7.25 (184.15) | 6.00 (152.40) |
| 1027 | 5.376/5.375 (136.53/136.50) | 5.437/5.436 (138.10/138.07) | 1 1/4 x 5/8 (31.75 x 16.00) | 8.63 (219.20) | 7.75 (196.85) |
| 1051 | 5.376/5.375 (136.53/136.50) | 5.437/5.436 (138.10/138.07) | 1 1/4 x 5/8 (31.75 x 16.00) | 8.63 (219.20) | 7.75 (196.85) |

* For C/T models, the input and output shaft diameters are reversed.

Backstopping, Bi-directional / Reverse-locking Ball Bearing Supported, Sprag Clutches

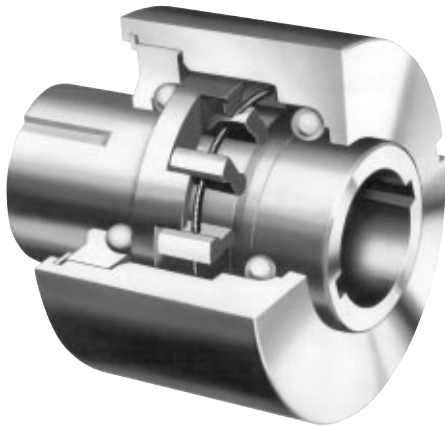

Available in six sizes, the Formsprag RL Clutch is a sprag type no-back which permits transmission of driving torque from input to output shaft in both directions of rotation, but restrains any feedback torque of the driven load from rotating the output shaft in either direction.

The RL Clutch is extremely simple in design and has a minimum number of moving parts. The outer race diameter is the same size as standard bearing dimensions, thus simplifying mounting and providing maximum strength in the assembly.

Model RL-47A through RL-160A

Models RL-47A through RL-160A are larger units applicable in an extensive torque capacity range. These models require lubrication.

Operating Principle

With the **outer race** held in a stationary or fixed position, torque is transmitted as follows:

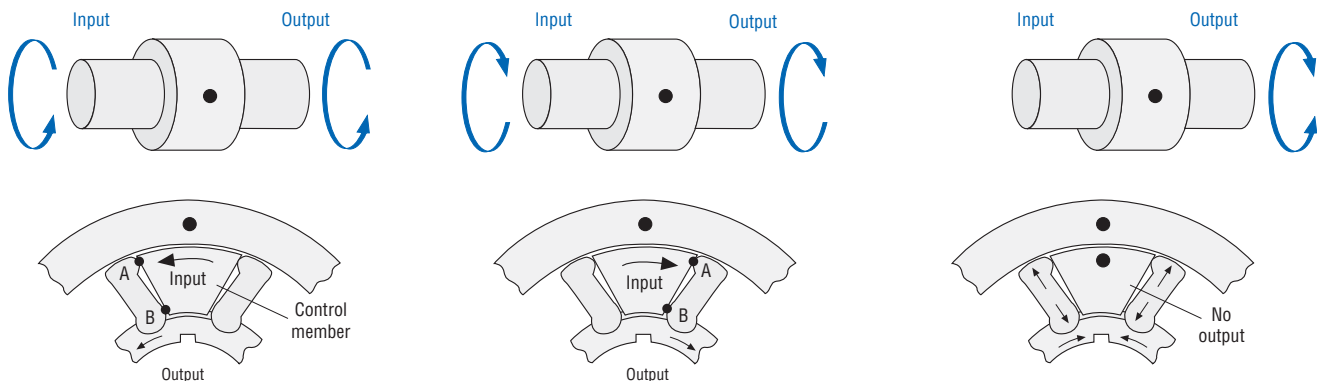

The control member projects between each pair of opposing sprags and when driving torque is applied to it, each projection first contacts a sprag at point "A" to disengage the sprag from the **outer race**. Then, the **control member** drives against the sprag at point "B" to transmit driving torque directly to the **output member**.

When input torque is reversed, the control member rotates a maximum of 6° to release the opposing set of sprags and then again drives the **output member** through point "B" on these sprags.

Any feedback torque from the **output member** is instantly stopped by the wedging of sprags between the fixed outer race and the **output member**—feedback torque never reaches the **control member**.



Applications

Due to the versatility of this device, it can perform a number of application functions other than the standard positive positioning or no-back type application. Generally, the mounting arrangement used determines which function may be obtained. The RL clutch has been used successfully in the following applications:

- Torque releasing (partial, single, or multiple revolution)
- Selective direction overrunning
- Dual drive (two-speed drive)
- Selective direction backstopping

Additional information concerning these applications is available upon request.

Design Advantages

- **Sprag-type design** — A complement of sprags arranged in opposing pairs insure that multiple contact surfaces always engage the outer race when feedback or back stopping conditions exist.
- **No backlash** — There is no backlash on the output shaft because sprags are in constant contact between the output member and the outer race. Any movement or torque applied to the output shaft results in instantaneous wedging of the sprags.
- **Wind-up** — Backlash of the output member with respect to the outer race is zero. However, when a feedback torque is applied to the output member, torsional wind-up will occur. Wind-up is approximately 2° when the feedback torque is equal to the rated capacity of the clutch.
- **High operating speeds** — Driving torque is transmitted in both directions of rotation at driving speeds ranging up to 1800 rpm by standard RL sprag type no-backs.
- **Equalized radial loading** — There are many equally spaced sprags contacting the outer race when feedback conditions exist to equalize radial loading and provide strong holding torque even against heavy feedback.

• Broad temperature range —

Formsprag RL reverse-locking clutches may be operated over a wide temperature range. Either grease or oil lubrication may be used. At extreme temperatures (usually below 20°F or above 150°F) the Formsprag application engineering department should be consulted for specific lubrication and metallurgical recommendations.

Other Considerations

Radial and thrust loads. The RL clutch is not designed to take radial or thrust loads. When such loads are present due to misalignment, gearing, sprockets, etc., external bearings should be utilized to accommodate these loads so that they will not be transferred to the clutch.

Alignment. In shaft to shaft connections the angular alignment of the shafts must be within .001" per inch of shaft length. Parallel alignment must be within .001" per inch of nominal shaft diameter. These figures are maximum and should not be exceeded as it will result in extreme loading on the clutch

Overhauling loads. Operating an RL clutch under overhauling load conditions (i.e., lowering a load with a crane) will occasionally result in a condition called "chatter." As the control fingers release the sprags, the load is momentarily unsupported and will accelerate the output member faster than the input member. The sprags will then arrest the load until continued motion of the input once again releases the sprags. The RL clutch, within its capacity, can arrest temporary overhauling loads, but it should not be subjected to continuously acting loads of this type. Such overhauling loads cause severe shock loading and also dissipate excessive energy through the RL clutch. This may have adverse effects on performance and life.

Continuously acting overhauling loads may be controlled by a suitable friction device (i.e., brake) which absorbs and diverts the dynamic torque and energy

from the RL clutch which holds the load in position. For such applications Formsprag should be consulted. Prototyping is recommended to determine the magnitude of the overhauling load and the method of using a friction device to control it.

Breakaway torque. When torque has caused the sprags to wedge between the socket member and the outer race, the control member fingers must disengage the sprags before driving can be resumed. This torque load can occur in response either to a load torque or an inertia torque. It is important that designers are aware of these inherent characteristics so that they may be considered and provided for in the design.

Input driving torque must always be sufficient to overcome any breakaway torques that may be present.

Breakaway torque may be due to one of three types:

1. Opposing load where the input drives against an output torque load.
2. Aiding load where the input torque is in the same direction as the output torque load.
3. Retained torque which is due to the internal resistance of the sprags after they have been wound up by the load and load is subsequently removed.

The breakaway torque may be as high as 25% more than the total torque to which the clutch has been loaded. For applications of this type consult Formsprag Application Engineering.

Lost motion. When the control element is in a neutral non-driving position, lost motion or lash of 2° to 3° in either direction of rotation from the neutral position will be required in order to disengage the sprags and permit drive.

Contact Formsprag application engineering department for specific information.



Selection

For the proper selection of an RL clutch, all possible torques that the clutch may be subjected to must be taken into consideration. The following procedure should be adhered to, to insure that the correct clutch is selected for a given application.

1. Determine torque requirements:
 - a. Determine load torque. If cyclic, use maximum value.
 - b. Determine additional torques due to brakes, friction, other machine functions, etc.
 - c. Determine inertia torque due to the acceleration or deceleration of the load. This value is dependent on WR^2 of the load and operating speed. See Technical Data.
2. Apply service factor from the table to the sum of all of the above torques involved in the system and select clutch from engineering data table.
3. Check operating speeds, available bores, and dimensional data of the clutch.
4. Check attachment data regarding mating elements in the system.
5. If all the above conditions are satisfactory, specify and order clutch by its model number.

Service factors

| Type of load | Factor |
|----------------------------------------------------------------------------------------------|-----------|
| Gradually applied—light shock with inertia torque of less than 50% of the driven load torque | 1.5 – 2.0 |
| Suddenly applied—moderate shock with inertia torque of 50% to 100% of driven load torque. | 2.0 – 2.5 |
| Suddenly applied—heavy shock with inertia torques 100% to 200% of driven load torque. | 3.0 – 3.5 |
| Suddenly applied—extreme shock with inertia torques in excess of 200% of driven load torque. | 4.0 – 6.0 |

Specifications

| Size | Nominal Shaft Diameter in. (mm) | Torque Capacity lb.in. (Nm) | Drag After Break-in* lb.in. (Nm) | Maximum Operating Speed** RPM | Shipping Weight lb. (kg) |
|---------|---------------------------------|-----------------------------|----------------------------------|-------------------------------|--------------------------|
| RL-35A | .374 (9.5) | 96 (10.8) | 1.0 (.113) | 1,800 | .33 (.14) |
| RL-47A | .500 (12.7) | 300 (34) | 1.0 (.113) | 1,800 | .95 (.4) |
| RL-72A | 1.000 (25.4) | 2,400 (271) | 2.0 (.226) | 1,800 | 2.5 (1.1) |
| RL-115A | 1.500 (38.1) | 8,500 (963) | 5.0 (.565) | 1,200 | 8.9 (4.0) |
| RL-130A | 2.000 (50.8) | 18,000 (2040) | 10.0 (1.13) | 1,200 | 13.3 (6.0) |
| RL-160A | 2.500 (63.5) | 26,500 (3003) | 20.0 (2.26) | 900 | 22.9 (10.4) |

* Break-in is equivalent to 24 hours of operation under ordinary circumstances.

** Maximum driving speed permissible with grease pack if inertia torque as determined by selection procedure does not exceed rated torque.

Technical data

Clutch torque based on speed and horsepower:

$$T = \frac{HP \times 63,000}{N}$$

Clutch torque due to dynamic loading:

$$T = .000407 (WR^2) N^2$$

Where:

HP = Horsepower

T = Torque, lb. in.

N = Operating speed, RPM

WR^2 = Effective inertia of load, lb.in.²

Installation

The outside diameters of clutches are made to standard ball bearing dimensions. The RL should be mounted in the bore of a housing of sufficient length to accommodate a ball bearing on each side of the clutch. These bearings provide supports, maintain alignment, and should be designed to carry any radial and/or thrust loads imposed on the input and output shafts.

Snap rings or a shoulder should be provided on the input and output shafts, to insure that any thrust loads which may be imposed on the shafts will be absorbed by the customer-provided bearings.

Care should be taken in the location of snap ring grooves, so that shafts do not rest against each other or their keys do not impose thrust loads on the snap rings in the bore of the clutch.

Lubrication

Grease. Formsprag RL clutches are lubricated at the factory with Lubriplate Low-Temp, a product of Fiske Brothers Refining Company. For temperatures below +20°F., or above 150°F. ambient consult Formsprag Application Engineering.

Oil. In applications where oil lubrication is to be used, factory supplied lubricant should be completely flushed from the clutch before installation. Use Mobil D.T.E. Heavy, Medium or any equivalent grade of good SAE-20 oil with high viscosity index (90VI min. 300 SSU at 100°F, 53 SSU at 210°F.)

RL-47A through 160A clutches are shipped from the factory packed with Fiske Brothers Lubriplate Low-Temp grease.

For further mounting and maintenance information, see Installation and Maintenance Bulletin No. 4501.

RL-35A

RL-47A through RL-160A

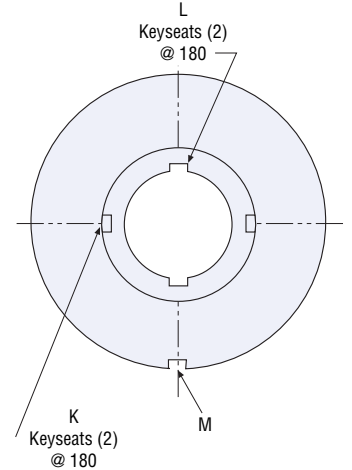
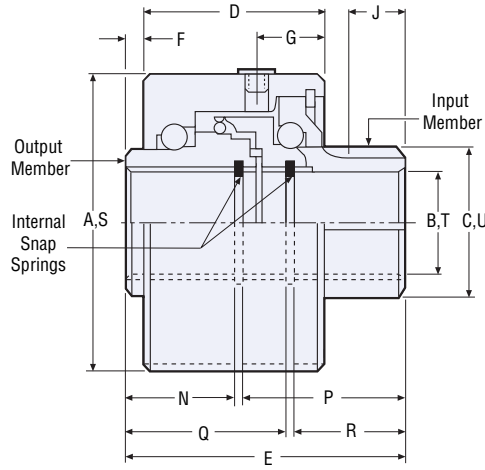
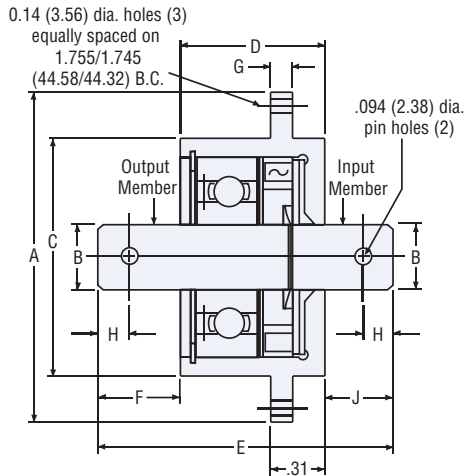

Dimensions inches (mm)

| Size | A | B | C | D* | E* | F** | G* | H | J* |
|---------|------------------------------------|--------------------------------|------------------------------|------------------|-------------------|-----------------|------------------|------------------|------------------|
| RL-35A | 2.005/1.995 (50.93/50.67) | .3742/.3738 (9.505/9.495) | 1.378/1.377 (35.00/34.96) | .843 (21.93) | 1.75 (44.45) | .500 (12.70) | .0625 (1.588) | .1875 (4.763) | .4063 (10.32) |
| RL-47A | 1.8504/1.8499 (47.000/46.987) | .500/.501 (12.700/12.725) | .783/.782 (19.89/19.86) | 1.563 (39.70) | 2.125 (53.98) | .031 (.787) | .688 (17.48) | | .438 (11.13) |
| RL-72A | 2.8346/2.8341 (71.999/71.986) | 1.000/1.001 (25.400/25.425) | 1.376/1.375 (34.95/34.93) | 1.719 (43.66) | 2.625 (66.68) | .156 (3.96) | .750 (19.05) | | .625 (15.88) |
| RL-115A | 4.5276/4.5271 (115.001/114.988) | 1.500/1.501 (38.100/38.125) | 2.001/2.000 (50.83/50.80) | 2.281 (57.94) | 3.141 (79.78) | .031 (.787) | .875 (22.23) | | .688 (17.48) |
| RL-130A | 5.1181/5.1173 (129.999/129.979) | 2.000/2.001 (50.800/50.825) | 2.845/2.844 (72.26/72.24) | 2.828 (71.83) | 4.172 (105.97) | .031 (.787) | 1.00 (25.40) | | 1.031 (26.19) |
| RL-160A | 6.2992/6.2982 (159.999/159.974) | 2.500/2.501 (63.500/63.525) | 3.876/3.875 (98.45/98.43) | 3.094 (78.59) | 4.719 (119.86) | .031 (.787) | 1.00 (25.40) | | .937 (23.80) |

* ± .010 (.254) except RL-35A

** ± .020 (.508) except RL-35A

Recommended Housing and Shaft Dimensions inches (mm)

| Size | S Housing Bore | T Shaft Dia. | U Bore Dia. | Keyseats | | | Key Engagement Lengths | | Shaft Engagement Lengths | |
|---------|------------------------------------|------------------------------|----------------------------------|------------------------------|------------------------------|-----------------------------|------------------------------|------------------|--------------------------------|------------------|
| | | | | K | L | M | N | R | Q | P |
| RL-47A | 1.8514/1.8520 (47.025/47.041) | .499/.498 (12.67/12.65) | .7833/.7838 (19.896/19.908) | 3/32 x 1/16 (2.39 x 1.27) | 3/32 x 1/16 (2.39 x 1.27) | 1/8 x 1/16 (3.18 x 1.59) | .781 (19.84) | .813 (20.65) | 1.156 (29.36) | 1.188 (30.18) |
| RL-72A | 2.8356/2.8362 (72.024/72.039) | .999/.988 (25.38/25.35) | 1.3763/1.3768 (34.958/34.971) | 5/32 x 1/16 (3.96 x 1.78) | 5/32 x 1/16 (3.96 x 1.78) | 1/8 x 1/16 (3.18 x 1.59) | 1.000 (25.40) | 1.000 (25.40) | 1.469 (37.31) | 1.469 (37.31) |
| RL-115A | 4.5286/4.5294 (115.026/115.047) | 1.499/1.498 (38.07/38.05) | 2.0013/2.0020 (50.833/50.851) | 1/4 x 1/8 (6.35 x 3.18) | 1/4 x 1/8 (6.35 x 3.18) | 1/4 x 1/8 (6.35 x 3.18) | 1.188 (41.27) | 1.188 (41.28) | 1.781 (45.24) | 1.781 (45.24) |
| RL-130A | 5.1191/5.1201 (130.025/130.051) | 1.999/1.998 (50.77/50.75) | 2.8453/2.8463 (72.271/72.296) | 5/16 x 5/32 (7.93 x 3.96) | 5/16 x 5/32 (7.93 x 3.96) | 1/4 x 1/8 (6.35 x 3.18) | 1.635 (41.27) | 1.635 (41.27) | 2.375 (60.33) | 2.375 (60.33) |
| RL-160A | 6.3002/6.3012 (160.025/160.050) | 2.499/2.498 (63.48/63.45) | 3.8763/3.8775 (98.458/98.489) | 1/2 x 1/4 (12.70 x 6.35) | 1/2 x 1/4 (12.70 x 6.35) | 1/4 x 1/8 (6.35 x 3.18) | 1.875 (47.62) | 1.875 (47.62) | 2.688 (68.28) | 2.688 (68.28) |