

INDUSTRIAL MAGZA
DIST. AUTORIZADO
MEX (55) 53 63 23 31
QRO (442) 1 95 72 60
MTY (81) 83 54 10 18
ventas@industrialmagza.com

MAVILOR
INFRANOR GROUP COMPANY



Motors

ISSUE 2001

AC Servo Motors BL 40/50/70 Series

The BL Series are synchronous electrical servomotors, with 3 winding phases, supplied with Sinusoidal or Trapezoidal current wave forms. The Feed-Back devices that produce the synchronization signal and speed (position, also in the Sinusoidal case), are a Resolver (BLS Series) or a Hall Effect devices (BLT Series). This "BRUSHLESS" technology provides:

- High dynamic response.
- Full speed condition, not limited by the "Brush Sparking effect".
- High thermal and dynamic characteristics, because of the motor's windings which are located in the stators.
- Very low maintenance.



BLS ~ Technical Specifications

ALL CHARACTERISTICS MEASURED
 AT 25°C AMBIENT TEMPERATURE

SYMBOLS UNITS

	SYMBOLS	UNITS
MAX MECHANICAL SPEED	n	rpm
STALL TORQUE ⁽¹⁾ ±10%	M _S	Nm
STALL CURRENT	I _S	A
PEAK TORQUE ±10%	M _J	Nm
TORQUE-WEIGHT RATIO	T _W	Nm/kg
EMF CONSTANT ±5%	K _E	Vs/rad
TORQUE CONSTANT ±5%	K _T	Nm/A
RELUCTANCE TORQUE ^(*)	T _R	Nm
WINDING RESISTANCE ±5%	R	Ω
WINDING INDUCTANCE ±5%	L	mH
ROTOR INERTIA	J	kg m ² 10 ⁻³
MECHANICAL TIME CONSTANT	T _M	ms
ELECTRICAL TIME CONSTANT	T _E	ms
THERMAL TIME CONSTANT	T _{TH}	s
THERMAL RESISTANCE	R _{TH}	°C/W
MASS	M	kg
RADIAL LOAD (at mid-length of shaft)	F _R	N
AXIAL LOAD	F _A	N
INSULATION		
PROTECTION		

(1) With an aluminium heat sink plate

(*) Respect to the Stall Torque

BLT ~ Technical Specifications

ALL CHARACTERISTICS MEASURED
 AT 25°C AMBIENT TEMPERATURE

SYMBOLS UNITS

	SYMBOLS	UNITS
MAX MECHANICAL SPEED	n	rpm
STALL TORQUE ⁽¹⁾ ±10%	M _S	Nm
STALL CURRENT	I _S	A
PEAK TORQUE ±10%	M _J	Nm
TORQUE-WEIGHT RATIO	T _W	Nm/kg
EMF CONSTANT ±5%	K _E	Vs/rad
TORQUE CONSTANT ±5%	K _T	Nm/A
RELUCTANCE TORQUE ^(*)	T _R	Nm
WINDING RESISTANCE ±5%	R	Ω
WINDING INDUCTANCE ±5%	L	mH
ROTOR INERTIA	J	kg m ² 10 ⁻³
MECHANICAL TIME CONSTANT	T _M	ms
ELECTRICAL TIME CONSTANT	T _E	ms
THERMAL TIME CONSTANT	T _{TH}	s
THERMAL RESISTANCE	R _{TH}	°C/W
MASS	M	kg
RADIAL LOAD (at mid-length of shaft)	F _R	N
AXIAL LOAD	F _A	N
INSULATION		
PROTECTION		

(1) With an aluminium heat sink plate

(*) Respect to the Stall Torque

BLS-40		BLS-55		BLS-71		BLS-72		BLS-73		BLS-74	
110 VAC	220 VAC	220 VAC	400 VAC	220 VAC	400 VAC	220 VAC	400 VAC	220 VAC	400 VAC	220 VAC	400 VAC
10,000		10,000		11,000		11,000		11,000		11,000	
0.36	0.36	0.7	0.7	0.8	0.8	1.9	1.9	2.7	2.7	3.4	3.4
2.57	1.24	1.4	0.77	2.11	1.13	3.96	2.37	3.91	2.2	4.2	2.25
1.44	1.44	2.8	2.8	3.2	3.2	7.6	7.6	10.8	10.8	13.6	13.6
0.6	0.6	0.5	0.5	0.53	0.53	1	1	1.17	1.17	1.21	1.21
0.08	0.17	0.29	0.53	0.22	0.41	0.28	0.46	0.4	0.71	0.47	0.87
0.14	0.29	0.5	0.91	0.38	0.71	0.48	0.8	0.69	1.23	0.81	1.51
<6%		<4%		<3.5%		<3.5%		<3.5%		<3.5%	
6	24.4	14.7	47	10.7	33.8	5.3	15.5	6.4	18.9	5.7	18.6
3.23	12	18.6	61	7.4	24	5.4	13.2	6.4	20	6.7	22
0.0024	0.0024	0.017	0.017	0.027	0.027	0.051	0.051	0.074	0.074	0.097	0.097
1.19	1.19	1.72	1.66	3.46	3.14	2.01	2.15	1.72	1.6	1.45	1.37
0.54	0.49	1.27	1.3	0.69	0.71	1.02	0.85	1	1.06	1.18	1.18
1,190	1,190	1,120	1,120	1,100	1,100	1,280	1,280	1,560	1,560	1,990	1,990
1.53	1.53	1.99	2.06	1.21	1.34	0.69	0.69	0.59	0.63	0.57	0.61
0.6	0.6	1.4	1.4	1.5	1.5	1.9	1.9	2.3	2.3	2.8	2.8
150		250		216		245		274		314	
80		100		98		98		98		98	
CLASS-F		CLASS-F		CLASS-F		CLASS-F		CLASS-F		CLASS-F	
IP-65		IP-65		IP-65		IP-65		IP-65		IP-65	
300x300x10		300x300x10		300x300x10		300x300x10		300x300x10		300x300x10	

BLT-40		BLT-55		BLT-71		BLT-72		BLT-73		BLT-74	
110 VAC	220 VAC	220 VAC	400 VAC	220 VAC	400 VAC	220 VAC	400 VAC	220 VAC	400 VAC	220 VAC	400 VAC
10,000		10,000		11,000		11,000		11,000		11,000	
0.36	0.36	0.7	0.7	0.8	0.8	1.9	1.8	2.7	2.7	3.4	3.4
3	1.50	1.71	0.95	2.58	1.4	4.87	2.77	4.82	2.7	5.15	2.76
1.44	1.44	2.8	2.8	3.2	3.2	7.6	7.20	10.8	10.8	13.6	13.6
0.6	0.63	0.51	0.51	0.54	0.54	1.02	0.96	1.19	1.19	1.23	1.23
0.12	0.24	0.41	0.74	0.31	0.57	0.39	0.65	0.56	1	0.66	1.23
0.12	0.24	0.41	0.74	0.31	0.57	0.39	0.65	0.56	1	0.66	1.23
<6%		<4%		<3.5%		<3.5%		<3.5%		<3.5%	
6	24.4	14.7	47	10.7	33.8	5.3	15.5	6.4	18.9	5.7	18.6
3.23	12	18.6	61	7.4	24	5.4	13.2	6.4	20	6.7	22
0.0024	0.0024	0.017	0.017	0.027	0.027	0.051	0.051	0.074	0.074	0.097	0.097
1.02	1.02	1.49	1.46	3.01	2.81	1.78	1.87	1.51	1.4	1.27	1.19
0.54	0.49	1.27	1.3	0.69	0.71	1.02	0.85	1	1.06	1.18	1.18
1,190	1,190	1,120	1,120	1,100	1,100	1,280	1,280	1,560	1,560	1,990	1,990
1.53	1.57	2.01	2.05	1.21	1.29	0.68	0.72	0.58	0.62	0.57	0.61
0.6	0.57	1.37	1.37	1.47	1.47	1.87	1.87	2.27	2.27	2.77	2.77
150		250		216		245		274		314	
80		100		98		98		98		98	
CLASS-F		CLASS-F		CLASS-F		CLASS-F		CLASS-F		CLASS-F	
IP-65		IP-65		IP-65		IP-65		IP-65		IP-65	
300x300x10		300x300x10		300x300x10		300x300x10		300x300x10		300x300x10	

AC Servo Motors BL 40/50/70 Series

Performance Curves

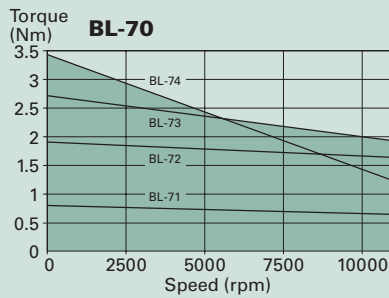
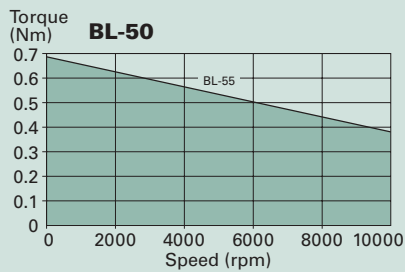
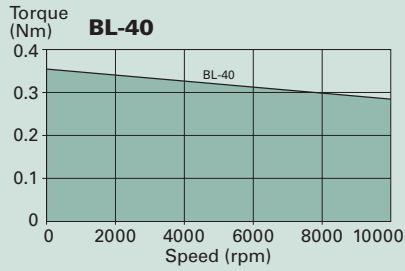

Resolver Specifications

	UNITS	BL-40	BL-50	BL-70
2T8 (Transmitter Speed 1)				
Input Voltage/Frecuency	V/kHz	7/10	10/4.5	
Primary Element		Rotor	Rotor	
Number of Speed		1X	1X	
Transformation Ratio		0.5 ± 5%	0.5 ± 5%	
Electrical Error	minutes	±10 max	±10 max	
Dielectric Strength	VAC/1 minute	500	500	
Mass	kg	0.04	0.13	
Rotor Moment of Inertia	kg m ² 10 ⁻³	0.0006	0.0032	
Operating Temperature Range	°C	-55 ~ + 155	-55 ~ +155	

Brake Specifications

	SIZE	TORQUE Nm	INERTIA kg cm ²	MASS kg
BL-40	01	0.4	0.016	0.10
BL-55	02	0.75	0.021	0.15
BL-71 / 72	03	1.5	0.068	0.18
BL-73 / 74	06	3	0.38	0.30

The BL Series incorporates the option of a fail-safe holding brake within the structure of the motor. Brake option is not available for short length version.

BL-40

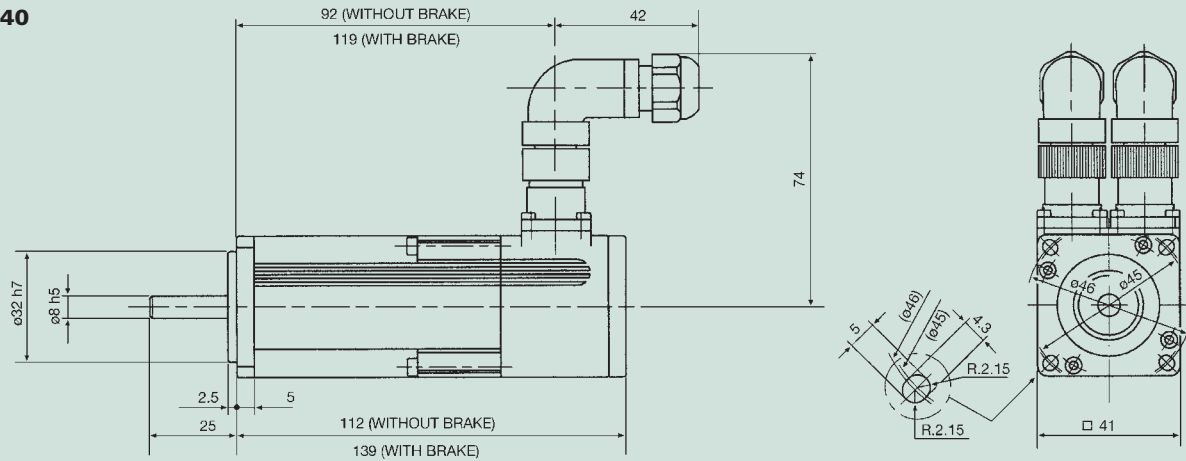

BL-50

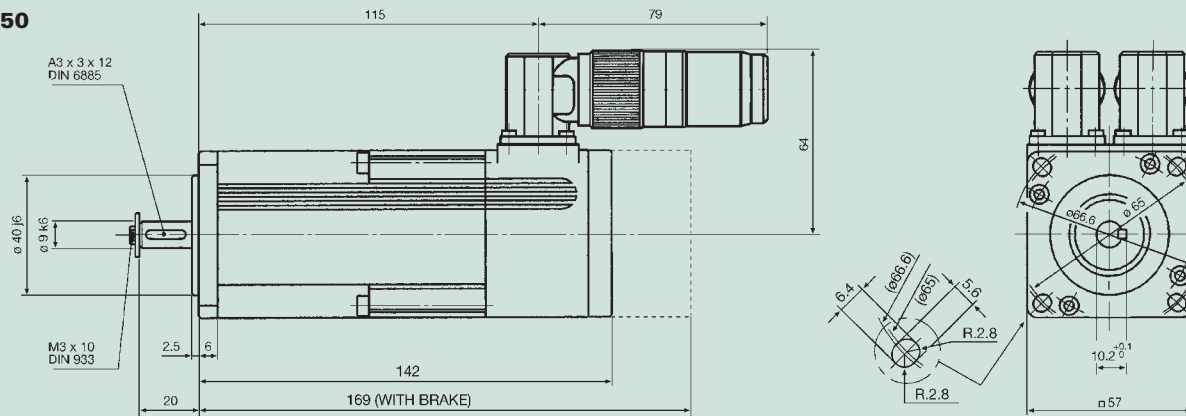

BL-70

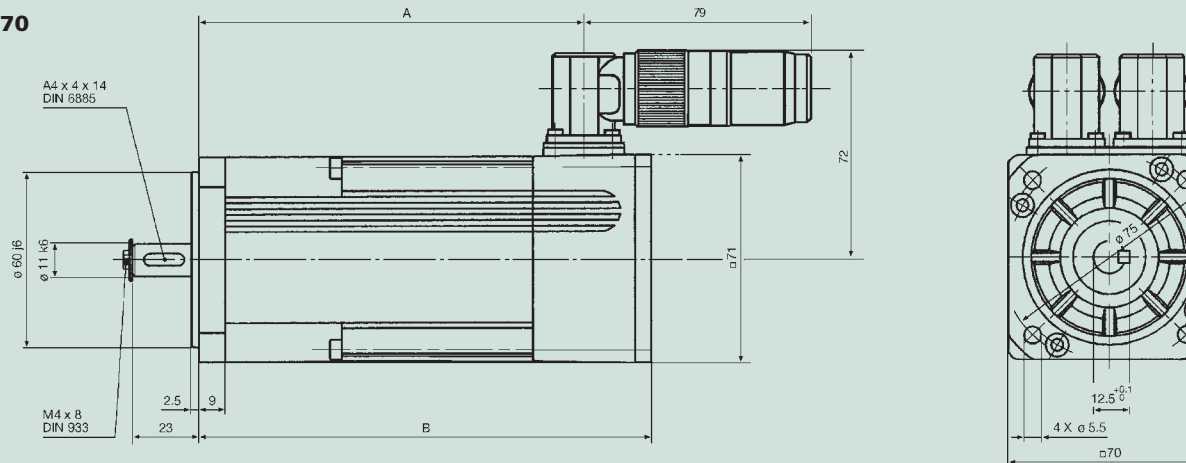

SHORT LENGTH VERSION (Not available with brake option)

	BL-71	BL-72	BL-73	BL-74
A	76.5	96.5	114.5	132.5
B	100.5	120.5	138.5	156.5

STANDARD VERSION (With or without brake option)

	BL-71	BL-72	BL-73	BL-74
A	81	101	119	137
B	128.5	148.5	166.5	184.5

The short length version must be specifically indicated in the order, as the product code applies to the standard version only.

Optional Accesories

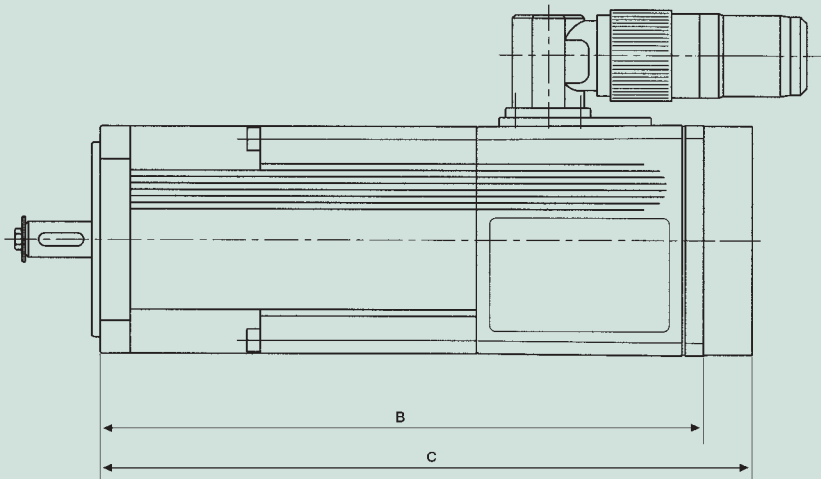

BL 50/70 With Fitted Encoder

Dimensions

WITHOUT BRAKE		BL-55	BL-71	BL-72	BL-73	BL-74
B		142	128.5	148.5	166.5	184.5
C	Encoder Type "A"	142	147	167	185	203
	Encoder Type "H"	142	128,5	148,5	166.5	184.5
	Encoder Type "K"	—	128,5	148,5	166.5	184.5

WITH BRAKE		BL-55	BL-71	BL-72	BL-73	BL-74
B		180.5	128.5	148.5	166.5	184.5
C	Encoder Type "A"	180.5	147	167	185	203
	Encoder Type "H"	—	136	156	166.5	184.5
	Encoder Type "K"	—	136	156	166.5	184.5

Encoder Specifications

	TYPE "A"	TYPE "H"	TYPE "K"
Waveform	Square Wave	Square Wave	
Line Counts	500 ppr	1000 ppr	2048 ppr
Channels	A, B, Z Open-Collector	A, B, Z, \bar{A} , \bar{B} , \bar{Z} / U, V, W, \bar{U} , \bar{V} , \bar{W} Line drives (RS422)	
Supply Voltage	5VDC \pm 10%	5VDC \pm 10%	
Frecuency Response	100 kHz	200 kHz	
Operating Temperature	-40 °C ~ +100 °C	-40 °C ~ +120 °C	