

MS-2 EExdIIC

MA-3 EExdIIC

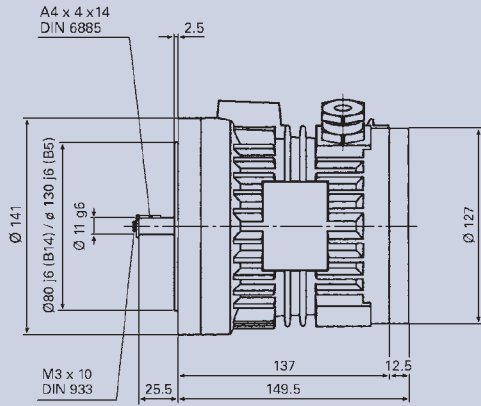

FLANGE B-14

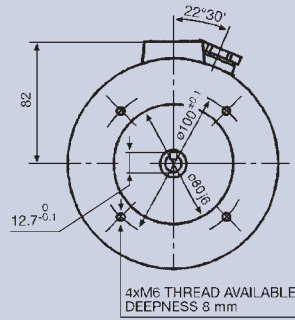

FLANGE B-5 (OPTIONAL)

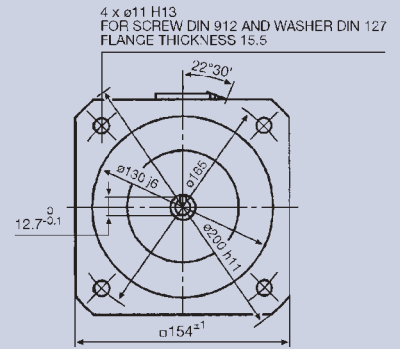

**MS-4 EExdIIC
 MS-6 EExdIIC
 MS-8 EExdIIC**

**MA-6 EExdIIC
 MA-10 EExdIIC**

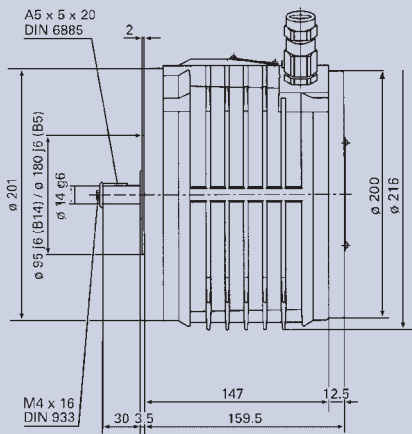

FLANGE B-14

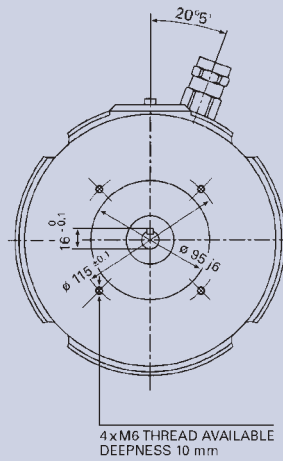

FLANGE B-5 (OPTIONAL)

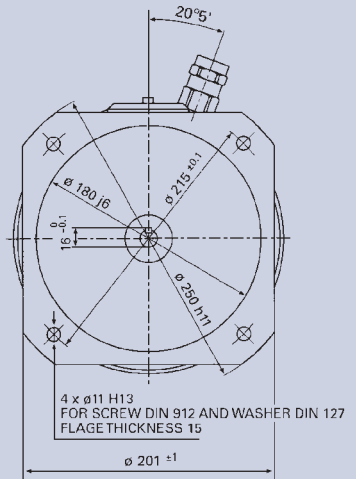

**MS-12 EExdIIC
 MS-22 EExdIIC**

**MA-20 EExdIIC
 MA-30 EExdIIC**

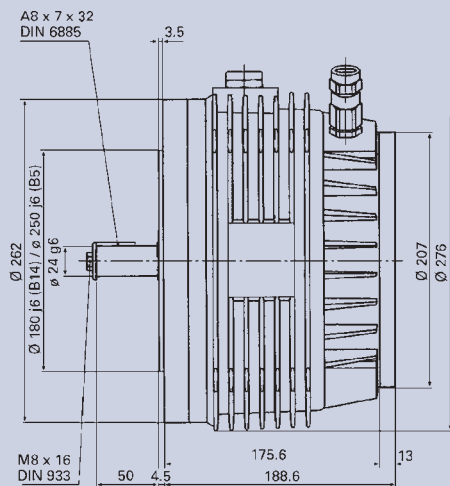

FLANGE B-14

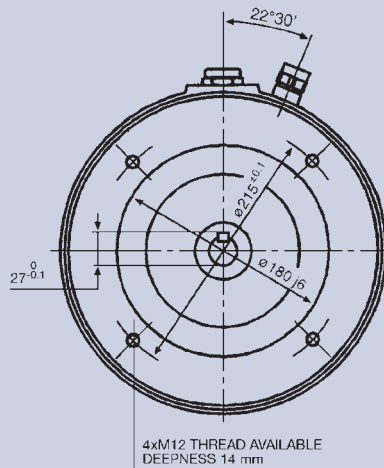

FLANGE B-5 (OPTIONAL)

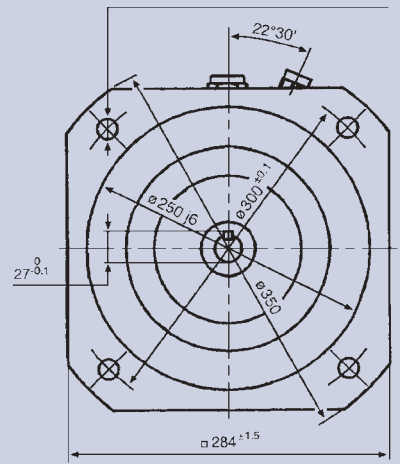

AC Servo Motors EExdIIc Series

Technical Specifications

ALL CHARACTERISTICS MEASURED AT 40° C AMBIENT TEMPERATURE EXCEPT TERMINAL RESISTANCE (25° C)			SYMBOLS	UNITS	MA-3	MA-6	MA-10	MA-20	MA-30
MAX MECHANICAL SPEED	n	rpm			9,000	6,000	6,000	6,000	6,000
STALL TORQUE (1) ±10%	M _S	Nm			1.3	3.6	5.8	10.0	16.0
STALL CURRENT	I _S	A			2.2	4.2	6.8	10.3	16.5
PEAK TORQUE ±10%	M _J	Nm			5.2	28.5	40.7	69.8	96.0
TORQUE-WEIGHT RATIO ±10%	T _W	Nm/kg			0.7	0.8	1.1	1.2	1.6
EMF CONSTANT ±5%	K _E	Vs/rad			0.3	0.5	0.5	0.6	0.6
TORQUE CONSTANT ±5%	K _T	Nm/A			0.6	0.9	0.9	1.0	1.0
RELUCTANCE TORQUE ±10%	T _R	Nm			<0.02	<0.1	<0.1	<0.2	<0.3
WINDING RESISTANCE ±5%	R	Ω			10.2	5.3	2.2	1.4	0.5
WINDING INDUCTANCE ±5%	L	mH			25.0	11.6	0.4	7.0	4.0
ROTOR INERTIA	J	kg m ² 10 ⁻³			0.04	0.30	2.10	0.80	1.60
MECHANICAL TIME CONSTANT	T _M	ms			2.0	3.8	3.6	2.1	1.6
ELECTRICAL TIME CONSTANT	T _E	ms			2.5	2.2	7.5	5.0	7.5
THERMAL TIME CONSTANT	T _{TH}	s			1,500	1,500	1,800	1,500	1,500
THERMAL RESISTANCE	R _{TH}	°C/W			1.1	0.6	0.5	0.4	0.4
MASS (motor with resolver)	M	kg						34	36
RADIAL LOAD (at mid-length of shaft)	F _R	N			218	410	410	600	600
AXIAL LOAD	F _A	N			218	225	225	390	390
INSULATION	CLASS-F								
PROTECTION	IP-65								
(1) With an aluminium heat sink plate					300x300x10	400x400x10		830x830x10	

Performance Curves

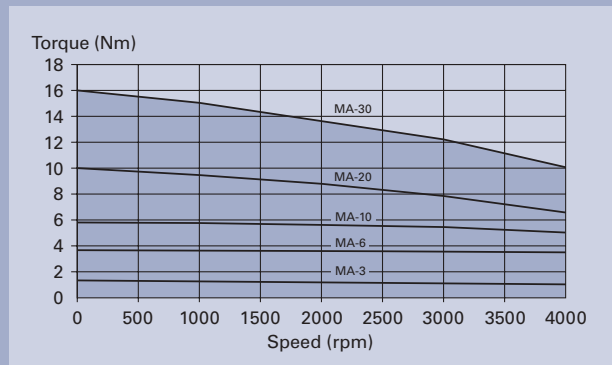

Resolver Specifications

	UNITS	2T8 (Transmitter Speed 1)
Input Voltage/Frecuency	V/kHz	10/4.5
Primary Element		Rotor
Number of Speed		1X
Transformation Ratio		0.5 ± 5%
Electrical Error	minutes	±10 max.
Dielectric Strength	VAC/1 minute	500
Mass	kg	0.230
Rotor Moment of Inertia	kg m ² 10 ⁻³	0.0123
Operating Temperature Range	°C	-55 ~ +155

Brake Specifications

	UNITS	MS-2	MS-4	MS-6	MS-8	MS-12	MS-22	MA-3	MA-6	MA-10	MA-20	MA-30
	SIZE	04	06	06	06	07	09	07 (*)	10	10	10	10
Holding Torque	Nm	1.2	2.5	2.5	2.5	5	12	1	4	4	8	8
DC Voltage	V	24	24	24	24	24	24	4.8	24	24	24	24
Input Power	W	8	12	12	12	16	18	5	22	22	22	22
Inertia	kg cm ²	0.05	0.23	0.23	0.23	0.65	2.14	0.08	0.3	0.3	0.3	0.3
Response Time												
Disengagement	ms	4	7	7	7	15	30	7	30	30	30	30
Engagement	ms	3	5	5	5	7	13	5	7	7	7	7
Mass	kg	0.19	0.3	0.3	0.3	0.6	1.1	0.3	0.8	0.8	0.8	0.8

(*) with chopper