

INDUSTRIAL MAGZA
DIST. AUTORIZADO
MEX (55) 53 63 23 31
QRO (442) 1 95 72 60
MTY (81) 83 54 10 18
ventas@industrialmagza.com

MAVILOR
INFRANOR GROUP COMPANY



Motors

ISSUE 2001

AC Servo Motors MA Series

- The short mechanical time constant makes it ideal for control operations.
- An extremely short electrical constant provides high peak torque at high speed.
- A high "theoretical" acceleration gives an extremely fast response time.
- High stall torque due to the absence of commutators bars.
- Low thermal resistance provides low working temperatures.
- High power to weight ratio, ideal for manipulator mounted motors.
- Air gap design, small diameter and short length.
- For many applications a separate position sensor is not required, the resolver can be used for deriving a position feed back signal as well as speed/current information.



Performance Curves

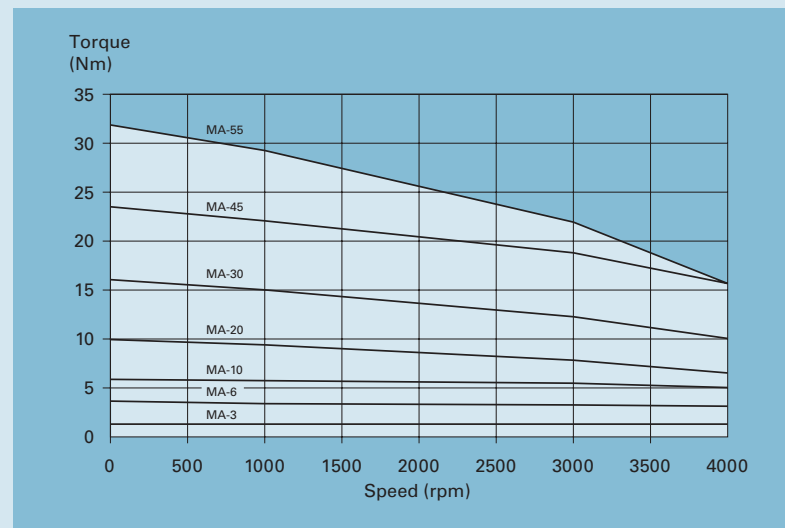

Technical Specifications

ALL CHARACTERISTICS MEASURED AT 25°C AMBIENT TEMPERATURE			MA-3	MA-6	MA-10	MA-20	MA-30	MA-45	MA-55	
SYMBOLS	UNITS									
MAX MECHANICAL SPEED	n	rpm	9000	6000	6000	6000	6000	6000	6000	
STALL TORQUE ⁽¹⁾ ±10%	M _S	Nm	1.3	3.6	5.8	10.0	16.0	23.4	31.8	
STALL CURRENT	I _S	A	2.2	4.2	6.8	10.3	16.5	24.1	32.7	
PEAK TORQUE ±10%	M _J	Nm	5.2	28.5	40.7	69.8	96.0	140.5	190.8	
TORQUE-WEIGHT RATIO ±10%	T _W	Nm/kg	0.7	0.8	1.1	1.2	1.6	1.7	1.9	
EMF CONSTANT ±5%	K _E	Vs/rad	0.3	0.5	0.5	0.6	0.6	0.6	0.6	
TORQUE CONSTANT ±5%	K _T	Nm/A	0.6	0.9	0.9	1.0	1.0	1.0	1.0	
RELUCTANCE TORQUE ±10%	T _R	Nm	<0.02	<0.1	<0.1	<0.2	<0.3	<0.4	<0.6	
WINDING RESISTANCE ±5%	R	Ω	10.2	5.3	2.2	1.4	0.5	0.4	0.2	
WINDING INDUCTANCE ±5%	L	mH	25.0	11.6	8.0	7.0	4.0	2.7	1.9	
ROTOR INERTIA	J	kg m ² 10 ⁻³	0.04	0.30	0.40	0.80	1.60	2.20	3.60	
MECHANICAL TIME CONSTANT	T _M	ms	2.0	3.8	2.1	2.1	1.6	1.6	1.6	
ELECTRICAL TIME CONSTANT	T _E	ms	2.5	2.2	3.6	5.0	7.5	6.6	7.6	
THERMAL TIME CONSTANT	T _{TH}	s	1,500	1,500	1,800	1,500	1,500	1,500	1,500	
THERMAL RESISTANCE	R _{TH}	°C/W	1.1	0.6	0.5	0.4	0.4	0.2	0.2	
MASS (motor with resolver)	M	kg	1.9	4.4	5.3	8.2	10.0	14.0	16.8	
RADIAL LOAD (at mid-length of shaft)	F _R	N	218	410	410	600	600	830	830	
AXIAL LOAD	F _A	N	218	225	225	390	390	410	410	
INSULATION	CLASS-F									
PROTECTION	IP-54									
(1) With an aluminium heat sink plate			300x300x10	400x400x10				830x830x10		

Resolver Specifications

	UNITS	2T8 (Transmitter Speed 1)
Input Voltage/Frequency	V/kHz	10/4.5
Primary Element		Rotor
Number of Speed		1X
Transformation Ratio		0.5 ± 5%
Electrical Error	minutes	±10 max.
Dielectric Strength	VAC/1 minute	500
Mass	kg	0.230
Rotor Moment of Inertia	kg m ² 10 ⁻³	0.0123
Operating Temperature Range	°C	-55 ~ +155

Brake Specifications

	SIZE	TORQUE Nm	INERTIA kg cm ²	MASS kg
MA-3	07 (*)	1	0.08	0.3
MA-6 / 10	10	4	0.30	0.8
MA-20 / 30	10	8	0.30	0.8
MA-45 / 55	10	12	0.30	0.8
(*) With chopper				

The MA Series incorporates the option of a fail-safe holding brake within the structure of the motor which holds the shaft without backlash on loss of electric current.

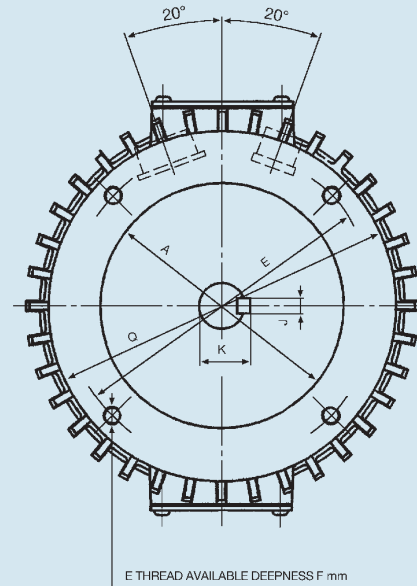
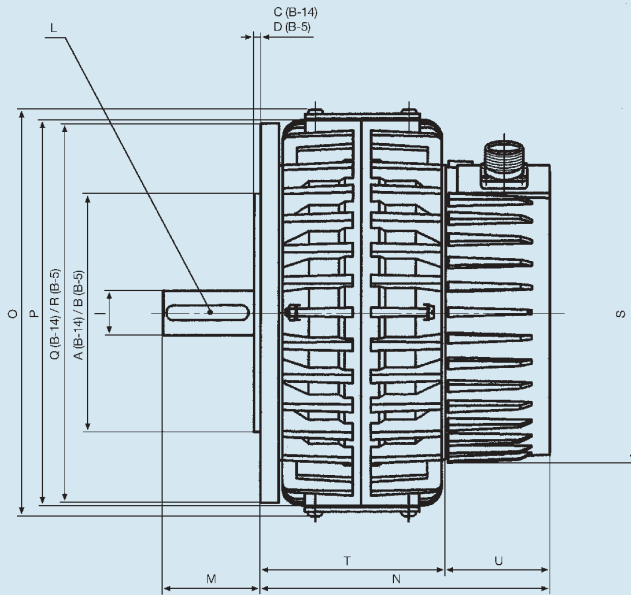

FLANGE B-14

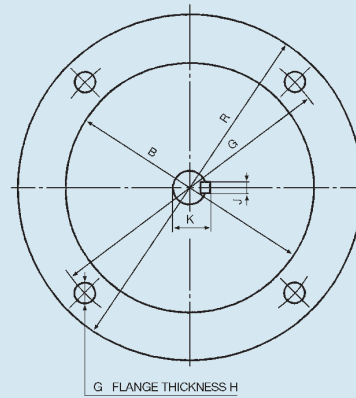

G FLANGE THICKNESS H

FLANGE B-5 (OPTIONAL)

MA-3

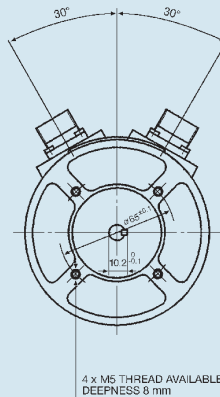
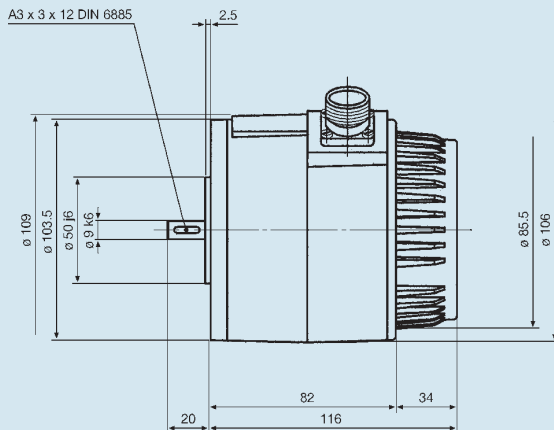

FLANGE B-14

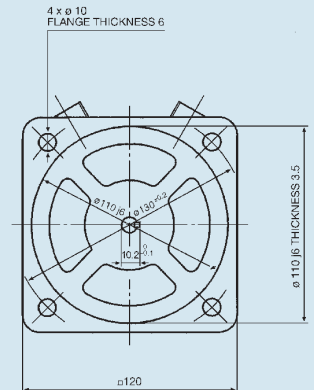

FLANGE B-5 (OPTIONAL)

AC Servo Motors MA Series

Dimensions

	MA-6	MA-10	MA-20	MA-30	MA-45	MA-55
A (j6)	ø95		ø130		ø180	
B (j6)	ø180				ø250	
C	3		3.5		4	
D	4				5	
E	ø115 4xM8		ø165 4xM10		ø215 4xM12	
F	10				12	
G	ø215 4xø15				ø300 4xø19	
H	10				17	
I (k6)	ø14		ø24		ø28	
J (N9)	5		8			
K (N9)	16		27		31	
L (DIN 6885)	A5x5x28		A8x7x45		A8x7x50	
M	34		50		60	
N	137.5		152.5		161.5	
O	ø178		ø218		ø278	
P	ø170		ø210		ø270	
Q	ø140		ø186		ø242	
R	ø250				□265	
S			ø165			
T	80		95		104	
U			57.5			

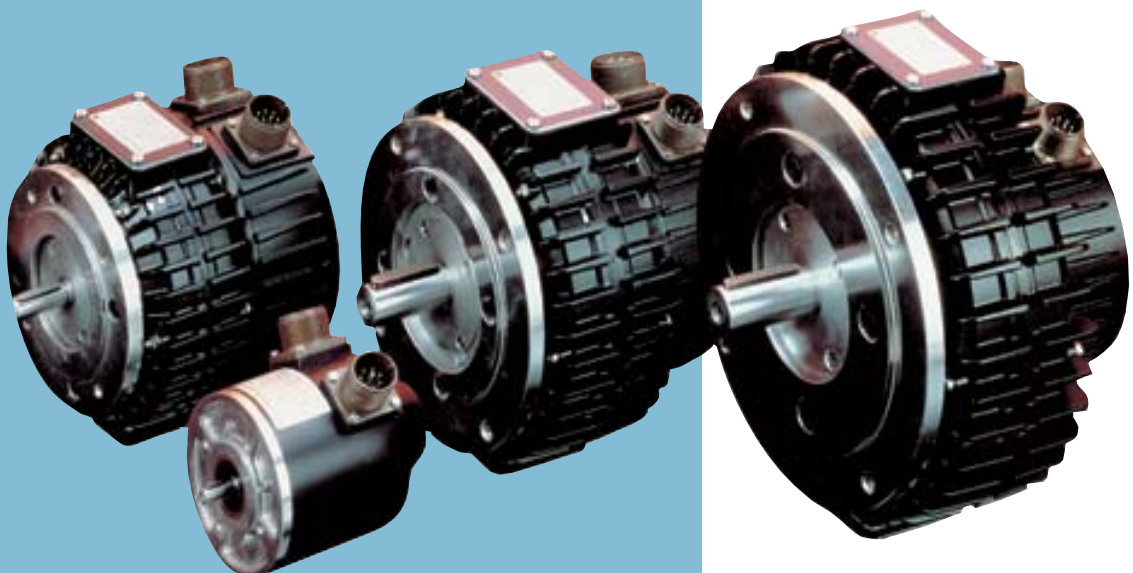

Optional Accesories

MSS Encoder Kit (no encoder)

	I
MSS-2	235
MSS-4	233
MSS-6	233
MSS-8	243.5
MSS-12	237.5
MSS-22	265.5
MSS-35	291
MSS-45	291

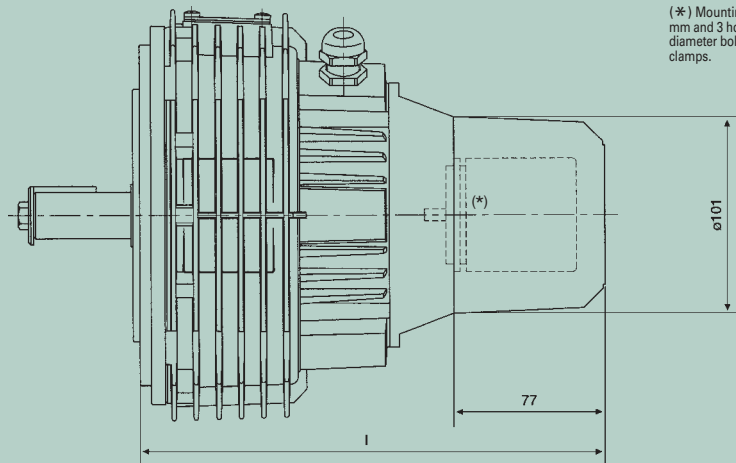

(*) Mounting pilot of 50 mm and 3 holes M4 on a 67,3 diameter bolt circle for fixing clamps.

MA Encoder Kit (no encoder)

	A
MA-6	237.5
MA-10	237.5
MA-20	252.5
MA-30	261.5
MA-45	274
MA-55	274

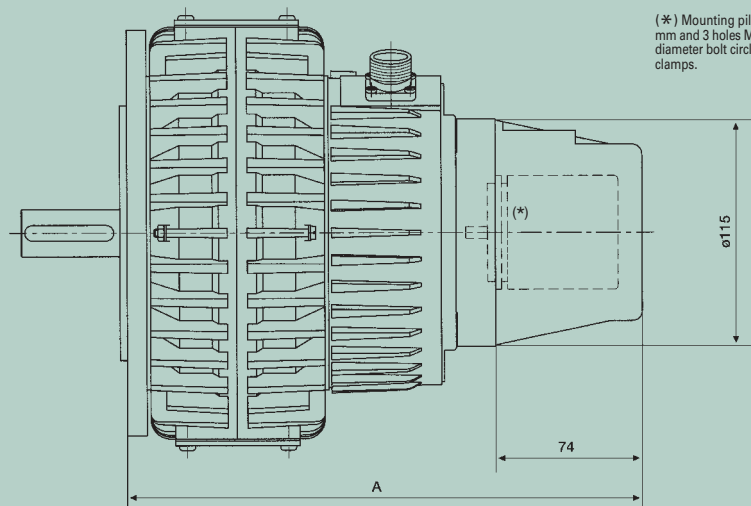

(*) Mounting pilot of 50 mm and 3 holes M4 on a 67,3 diameter bolt circle for fixing clamps.

BL 110/140 Encoder Kit (no encoder)

	A
BL-111	282
BL-112	307
BL-113	332
BL-114	357
BL-115	382
BL-141	346
BL-142	367
BL-143	411
BL-144	453

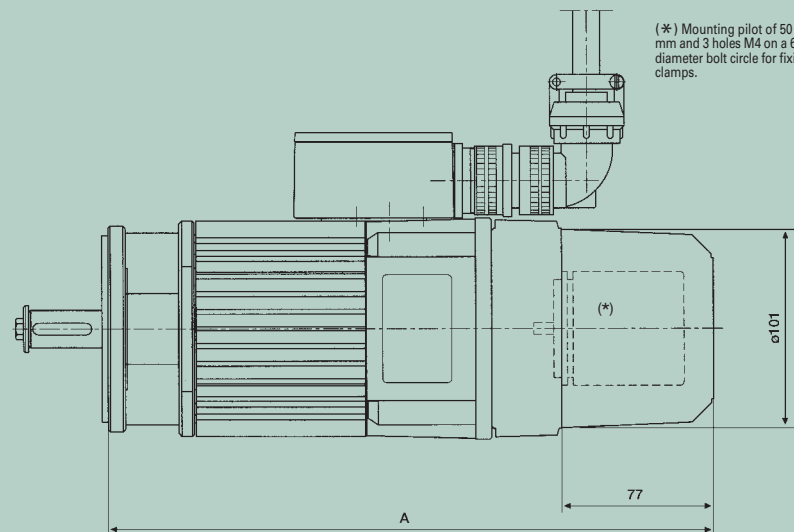

(*) Mounting pilot of 50 mm and 3 holes M4 on a 67,3 diameter bolt circle for fixing clamps.