

AC Servo Motors MSA Series

- Very compact.
- Reduced diameter and length.
- Axial magnetic flux.
- Low cogging torque.
- Excellent torque/weight/volume ratio.

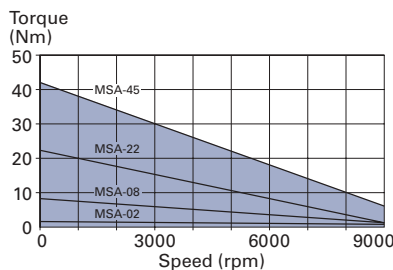

Performance Curves



Brake Specifications

	SIZE	TORQUE Nm	INERTIA kg cm ²	MASS kg
MSA-2	03	2	0.068	0.18
MSA-8	06	9	0.54	0.50
MSA-22	08	36	5.56	1.75
MSA-45	08	36	5.56	1.75

Resolver Specifications

	UNITS	2T8 (Transmitter Speed 1)
Input Voltage/Frecuency	V/kHz	10/4.5
Primary Element		Rotor
Number of Speed		1X
Transformation Ratio		0.5 ± 5%
Electrical Error	minutes	±10 max.
Dielectric Strength	VAC/1 minute	500
Mass	kg	0.230
Rotor Moment of Inertia	kg m ² 10 ⁻³	0.0123
Operating Temperature Range	°C	-55 ~ +155

Technical Specifications

ALL CHARACTERISTICS MEASURED AT 25°C AMBIENT TEMPERATURE			MSA-2	MSA-2	MSA-8	MSA-8	MSA-22	MSA-22	MSA-45
	SYMBOLS	UNITS	220 VAC	400 VAC	220 VAC	400 VAC	220 VAC	400 VAC	400 VAC
MAX MECHANICAL SPEED	n	rpm	10000	10000	6500	6500	6000	6000	4500
STALL TORQUE (1) ±10%	M _S	Nm	1.9	1.9	9	9	26	26	44
STALL CURRENT	A	A	5.48	3.54	9.12	9.12	27.85	15.97	26.19
PEAK TORQUE ±10%	M _J	Nm	7.6	7.6	36	36	104	104	176
TORQUE-WEIGHT RATIO	T _W	Nm/kg	0.70	0.70	1.125	1.125	1.48	1.48	1.63
EMF CONSTANT ±5%	K _E	Vs/rad	0.20	0.31	0.57	0.57	0.54	0.94	0.97
TORQUE CONSTANT ±5%	K _T	Nm/A	0.35	0.54	0.99	0.99	0.93	1.63	1.68
RELUCTANCE TORQUE (Respect to the Stall Torque)	T _R	Nm	<1.5%	<1.5%	<1.5%	<1.5%	<1.5%	<1.5%	<1.5%
WINDING RESISTANCE ±5%	R	Ω	2.90	7.07	1.50	1.50	0.26	0.78	0.41
WINDING INDUCTANCE ±5%	L	mH	11.50	28.00	15.00	15.00	5.56	14.00	10.90
ROTOR INERTIA	J	kg m ² 10 ⁻³	0.05	0.05	0.45	0.45	2.3	2.3	4
MECHANICAL TIME CONSTANT	T _M	ms	2.09	2.12	1.20	1.20	1.19	1.17	1.01
ELECTRICAL TIME CONSTANT	T _E	ms	3.97	3.96	10.00	10.00	21.38	17.95	26.59
MASS (Motor with resolver)	M	kg	2.7	2.7	8	8	17.6	17.6	27
RADIAL LOAD	F _R	N	218	218	410	410	600	600	700
AXIAL LOAD	F _A	N	218	218	225	225	400	400	400
INSULATION			CLASS-F	CLASS-F	CLASS-F	CLASS-F	CLASS-F	CLASS-F	CLASS-F
PROTECTION			IP-65	IP-65	IP-65	IP-65	IP-65	IP-65	IP-65
(1) With an aluminium heat sink plate			300x300x10		400x400x10		700x700x20		

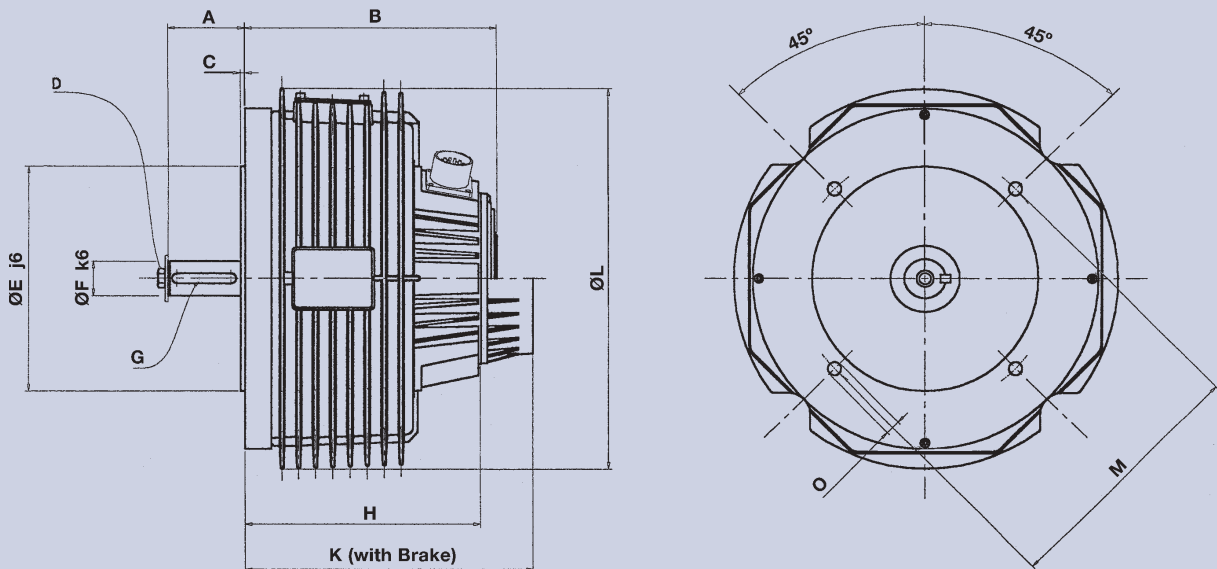

MODELS	A	B	C	D DIN933	E j6	F k6	G DIN6885	H	K	L	M	O
MSA-2	23	94.5	2.5	M4x8	Ø50	Ø11	A4x4x14	85.5	151	Ø118	Ø65	4xM5
MSA-8	40	145	3	M6x16	Ø95	Ø16	A5x5x30	136	170	Ø192	Ø115	4xM8
MSA-22	50	178	3.5	M8x16	Ø130	Ø24	A8x7x32	166	202	Ø275	Ø165	4xM10
MSA-45	60	200	3.5	M10x22	Ø180	Ø28	A8x7x50	188	224	Ø305	Ø215	4xM12