

This manual describes the **option "d"** of the **SMT-BD1** amplifier: **Master/slave electronic gearing**. The general information about the digital amplifier commissioning are described in the standard **SMT-BD1** manual. This manual may be used in conjunction with appropriate and referenced drawings pertaining to the various specific models.

Maintenance procedures should be attempted only by highly skilled technicians (EN 60 204.1 standard) using proper test equipment.

The conformity with the standards and the "CE" approval are only valid if the items are installed according to the recommendations of the racks and amplifiers manuals.

Any contact with electrical parts, even after power down, may involve physical damage.

Wait for 30 seconds after power down before handling the rack or the amplifiers (residual voltage).

INFRANOR does not assume any responsibility for any physical or material damage due to improper handling or wrong descriptions of the ordered items.

Infranor reserves the right to change any information contained in this manual without notice.

This manual is a translation of the original document and does not commit INFRANOR's responsibility. The french manual is the only reference document.

OPTION "d"

MASTER / SLAVE ELECTRONIC GEARING WITH THE SMT-BD1/d AMPLIFIER

CONTENTS

CONTENTS.....	4
CHAPTER 1 - GENERAL DESCRIPTION	5
CHAPTER 2 - SPECIFICATIONS.....	6
1 - TECHNICAL DATAS	6
2 - AMPLIFIER BLOCK DIAGRAM.....	7
3 - STORED FAULT	8
CHAPTER 3 - INPUTS - OUTPUTS.....	9
1 - X2 POSITION CONNECTOR.....	9
1.1 - Pin reference	9
1.2 - Logic inputs/outputs specifications.....	10
2 - X3 TEST CONNECTOR	10
CHAPTER 4 - CONNECTIONS	11
1 - CONNECTION DIAGRAMS	11
1.1 - Connection of the master amplifier.....	11
1.2 - Connection of the master encoder.....	11
2 - MANDATORY WIRING.....	12
CHAPTER 5 - ADJUSTABLE PARAMETERS.....	13
1 - OPERATION MODE.....	13
2 - APPLICATION PARAMETERS.....	13
3 - POSITION REGULATOR PARAMETERS	14
4 - POSITION REFERENCE ACQUISITION.....	15
CHAPTER 6 - COMMISSIONING	16
1 - IMPORTANT WARNING.....	16
2 - CHECKING THE CONFIGURATION.....	16
3 - POWERING.....	16
4 - START AND ADJUSTMENT.....	17
5 - MANUAL ALIGNMENT OF THE SLAVE AXIS	18
6 - AUTOMATIC ALIGNMENT OF THE SLAVE AXIS	18
7 - MASTER/SLAVE SYNCHRONIZATION USING THE ANALOGUE INPUT COMMAND.....	20
CHAPTER 7 - FAULT FINDING.....	22
1 - "POSITION" FAULT.....	22
2 - "BUSY" FAULT.....	22
3 - OPERATION PROBLEMS.....	22
3.1 - Loud crackling noise in the motor at standstill.....	22
3.2 - Loud noise in the motor at standstill and when running	22
3.3 - Loud noise in the motor when running.....	23
3.4 - Motor position oscillation at standstill.....	23
CHAPTER 8 - APPENDIX	24
LOCATION DIAGRAM OF THE HARDWARE OPTIONS.....	24

CHAPTER 1 - GENERAL DESCRIPTION

The master / slave electronic gearing applications require the **SMT-I1-BD1** or **SMT-I2-BD1** daughter boards on the **SMT-BD1** amplifier. In this configuration, the **SMT-BD1/d** amplifier controls the motor shaft position according to the position input command emitted by the master axis. The master axis position input command is received as two differential encoder signals: A, /A and B, /B in quadrature. These signals enter the amplifier position connector X2. This kind of input allows a direct interfacing with an encoder mounted on the master motor or on a second amplifier controlling the master motor (a master amplifier SMT-BD1 or SMTB.Si-2Tz can control up to 10 slave amplifiers). Both configurations are described below.

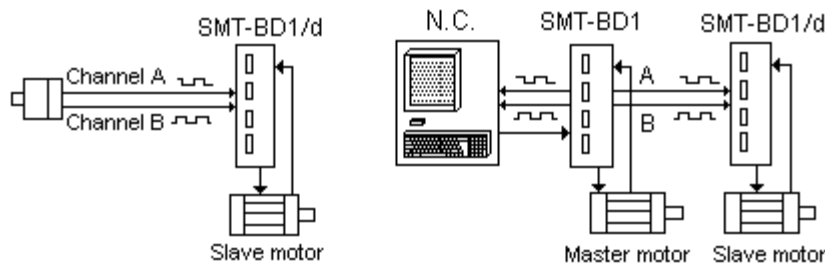

The reduction ratio between master motor and slave motor is defined by the encoder resolution ratio of each motor. The master motor encoder resolution is programmable between 1 and 8192 ppr.

When the slave motor is disabled (**ENABLE** input not activated), the input pulses emitted by the master motor are not counted. When activating the **ENABLE** input, the slave motor is controlled at its current position and follows the master motor pulses.

The position error control between master motor and slave motor is made in the amplifier. The position regulator used allows to cancel the position error when the speed of both motors is constant.

It is possible to introduce a shift between master motor and slave motor for a manual alignment by using the JOG+ and JOG- inputs. These inputs are connected to two push buttons and allow to move the slave motor of a quarter of an encoder pulse of its resolution in the positive or negative direction at each activation.

It is also possible to make an automatic alignment between master motor and slave motor at each enabling. This kind of application requires a **SMT-BD1** amplifier for the control of the master motor.

CHAPTER 2 - SPECIFICATIONS

1 - TECHNICAL DATAS

Position input command of the slave motor	Two encoder pulse trains A and B Max. frequency = 250 KHz
Reduction ratio between master and slave motors	Master encoder resolution / Slave encoder resolution
Programmable encoder resolution of the slave motor	Max. 8 192 ppr up to 900 rpm Max. 4 096 ppr up to 3 600 rpm Max. 1 024 ppr up to 14 000 rpm
Drive position repetability	1 encoder edge (a quarter of an encoder pulse)
Drive position accuracy (*)	8 Arc mins + 1 encoder edge as standard (2 arc mins + 1 encoder edge on special request)
(*) The total accuracy must take into account the resolver accuracy.	
Position regulator PIV + Feedforward	Sample period: 0,5 ms Integrator ant saturation system Adjustable digital gains Antiresonance filter
Position loop bandwidth	Cut-off frequency for 45° phase shift Selectable: 50 Hz, 75 Hz or 100 Hz
Logic outputs	POS: Position following OK
Logic inputs	JOG+ : Positive shift. Max. frequency = 1 kHz JOG- : Negative shift. Max. frequency = 1 kHz

2 - AMPLIFIER BLOCK DIAGRAM

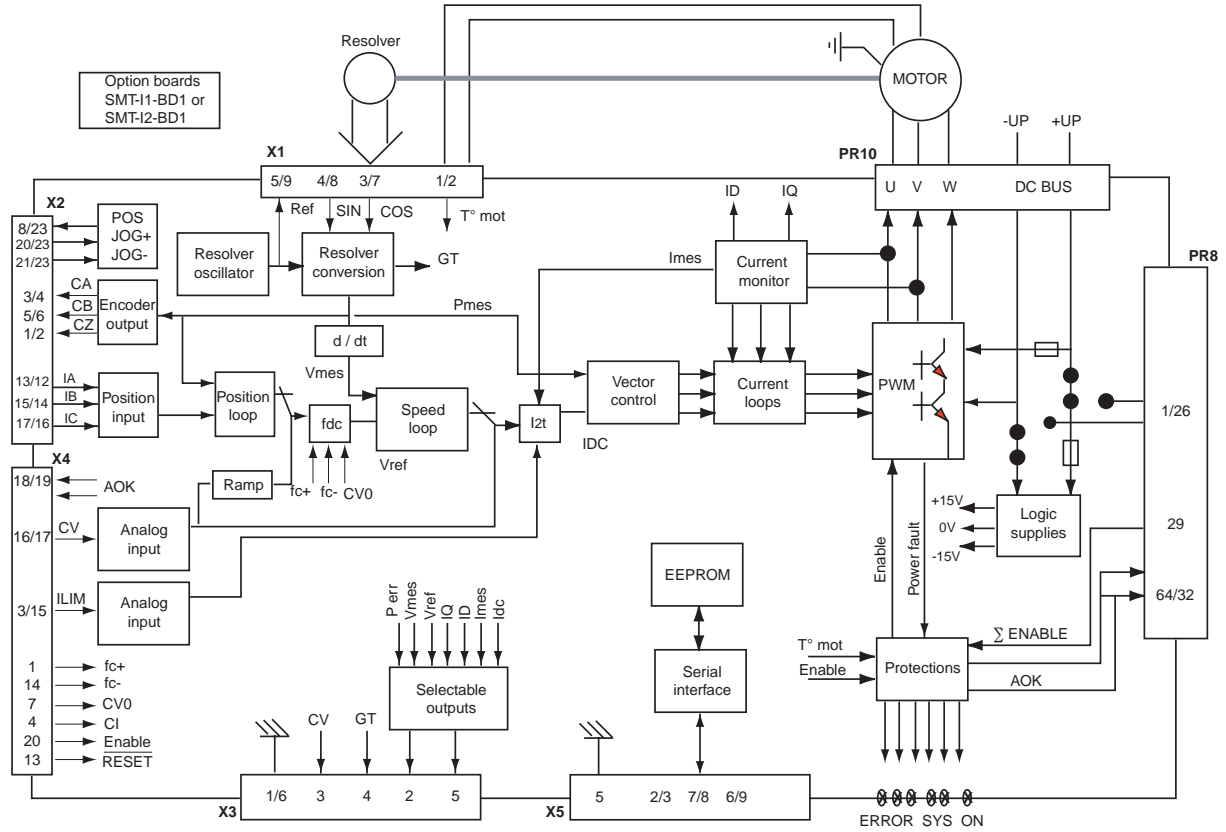

3 - STORED FAULT

PROTECTION	DISPLAY CODE	LED
Position following error	Position	● ● ● ☼

● = LED is unlit ☼ = LED is lit

The stored fault can be cancelled:

- by the RESET function of the **BPCW** software,
- by the fault RESET input (pin 13 of X4),
- by turning off the amplifier supply.

CHAPTER 3 - INPUTS - OUTPUTS

1 - X2 POSITION CONNECTOR

1.1 - PIN REFERENCE

PIN	FUNCTION	I/O	REMARK
1	CZ/	O	Motor encoder output of the zero pulse / (5 V, 20 mA max)
2	CZ	O	Motor encoder output of the zero pulse
3	CA/	O	Motor encoder output channel A/ (5 V, 20 mA max)
4	CA	O	Motor encoder output channel A
5	CB/	O	Motor encoder output channel B/ (5 V, 20 mA max)
6	CB	O	Motor encoder output channel B
7,10,11	0 V		GND
12	IA/	I	Master encoder input channel A/ (5 V, consumption: 2 mA)
13	IA	I	Master encoder input channel A
14	IB/	I	Master encoder input channel B/ (5 V, consumption: 2 mA)
15	IB	I	Master encoder input channel B
16, 17	Reserved		Reserved
18,19	Reserved		Reserved
8	POS	O	Logic output POS: Position following OK
9,22	Reserved		Reserved
20	JOG+	I	Logic input JOG+ : Positive shift
21	JOG-	I	Logic input JOG- : Negative shift
23	0 V I/O		0 Volt logic inputs and outputs
24	+ 5 V	O	+/- 5 % 300 mA available with jumper 5 V closed for master encoder supply (if necessary)
25	0 V		

1.2 - LOGIC INPUTS/OUTPUTS SPECIFICATIONS

The JOG+ and JOG- inputs are "optocoupled" and operate in positive logic, as shown below. The input voltage corresponding to level 1 is between 5 and 24 V.

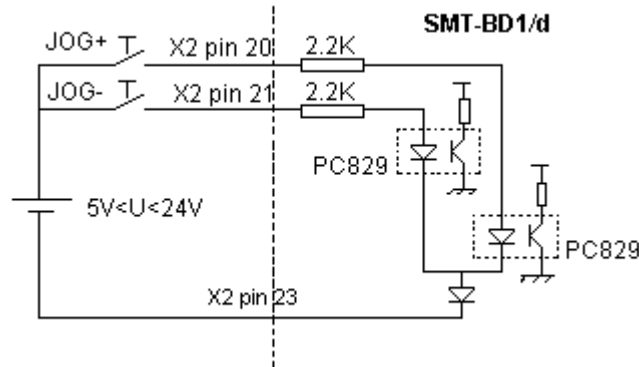

The POS output is an "open collector" and "optocoupled". The transistor is inhibited if a fault occurs. The traditional application scheme is shown below. The maximum output current is 5 mA.

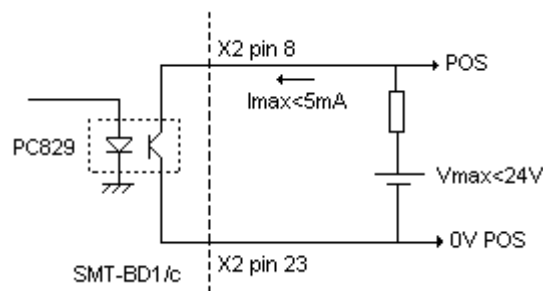

2 - X3 TEST CONNECTOR

PIN	FUNCTION	CHARACTERISTICS
1 - 6	0 V	
2	DAC 1 output	± 10 V resolution 8 bits, linearity: 2 % (IDC, Imon., ID, IQ, Vref, Vmon., Pos err) *
3	Speed input command CV	± 10 V for \pm maximum speed
4	Speed signal GT	± 8 V for $\pm 14\ 000$ rpm
5	DAC 2 output	± 10 V resolution 8 bits, linearity: 2 % (IDC, Imon., ID, IQ, Vref, Vmon., Pos err)*

* See "BPCW Options" manual, part "Digital oscilloscope".

Linearity: 10 % on logic boards 01612A, 01612B and 01612C.

CHAPTER 4 - CONNECTIONS

1 - CONNECTION DIAGRAMS

1.1 - CONNECTION OF THE MASTER AMPLIFIER

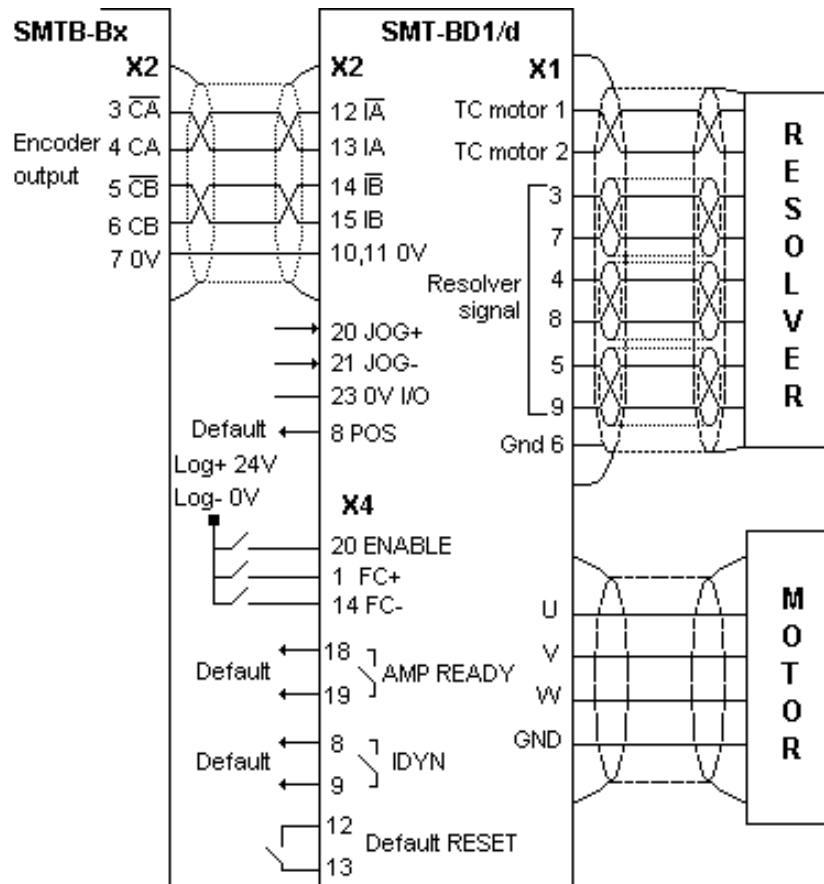

1.2 - CONNECTION OF THE MASTER ENCODER

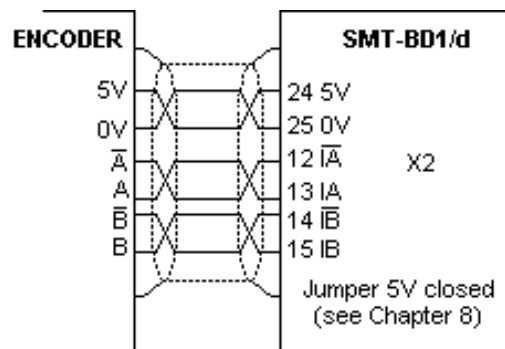

2 - MANDATORY WIRING

For the incremental position input command signals **A** and **B** of the master-slave connection, use a cable with a **360° shield connection via the metal plated connectors** at both cable ends (see standard manual of the SMT-BD1 digital amplifier, chapter 8, part 6) and **connect the 0 Volt of both master and slave** (pin **GND** on the **X2** connector).

The crossing of the A and B or A and A/ or B and B/ signals on the incremental position input command changes the rotation direction of the slave motor with regard to the master motor.

CHAPTER 5 - ADJUSTABLE PARAMETERS

The parameters used for electronic master/slave gearing applications are accessible via the **Indexer / Electronic Gearbox** submenu of the **Advanced functions** menu, in the **BPCW** software.

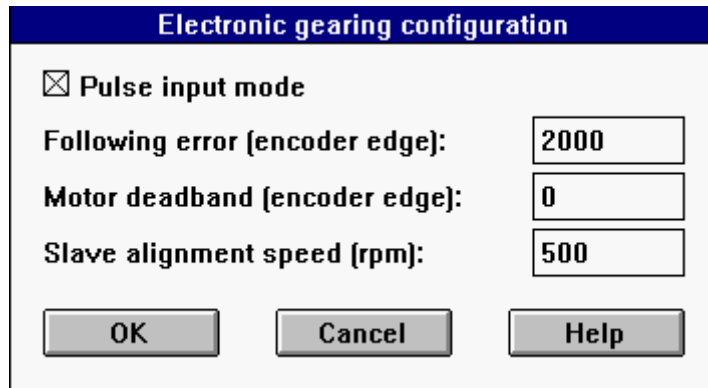

1 - OPERATION MODE

The operation as an electronic gearbox is selected by the **Pulse input mode** function in the **Indexer / Electronic Gearbox** menu of the **Advanced functions** menu.

This mode corresponds to the slave motor position control with a PIV + feedforward regulator. The position input command emitted by the master motor is received as an incremental input command on the X2 connector.

2 - APPLICATION PARAMETERS

The **Encoder resolution** parameter is accessible in the **ENCODER RESOLUTION** module of the adjustment panel in the **BPCW** software. It defines the number of encoder pulses for one revolution of the slave motor shaft. The limit value of this parameter according to the maximum motor speed (**Maximum speed**) is indicated in the chart below:

MAX. SPEED (rpm)	900	3 600	14 000
MAX. ENCODER RESOLUTION	8192	4096	1024

The following parameters are accessible via the **Indexer / Electronic Gearbox** submenu of the **Advanced functions** menu.

The **Following error** parameter defines the maximum permissible value of the position error. When the position error reaches half of this value, the **POS** output is disabled and the following error fault (Position error) is blinking on the amplifier front panel. When the position error reaches the value defined by the **Following error** parameter, the following error fault (**Position** error) is released and the amplifier is disabled. This parameter is expressed as encoder edges (motor resolution encoder pulses x 4). The adjustment range is between 0 and 32 767 edges.

The **Motor deadband** parameter defines a tolerance range of the position input command, where the position loop is open. This parameter is expressed as encoder edges (motor resolution encoder pulses x 4). The adjustment range is between 0 and 32 767 edges.

The **Alignment speed (rpm)** parameter defines the maximum motor speed during the automatic alignment phase of the slave motor according to the master motor reference position. The motion occurs according to a trapezoidal path as shown below. The acceleration and deceleration times are automatically calculated in order to avoid any current saturation in the amplifier.

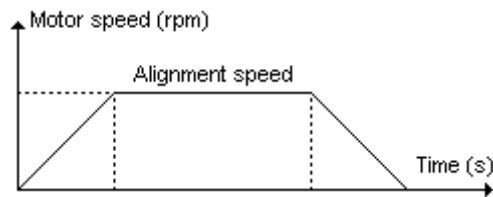

3 - POSITION REGULATOR PARAMETERS

The regulator structure used for the **Indexer / Electronic Gearbox** control is described below:

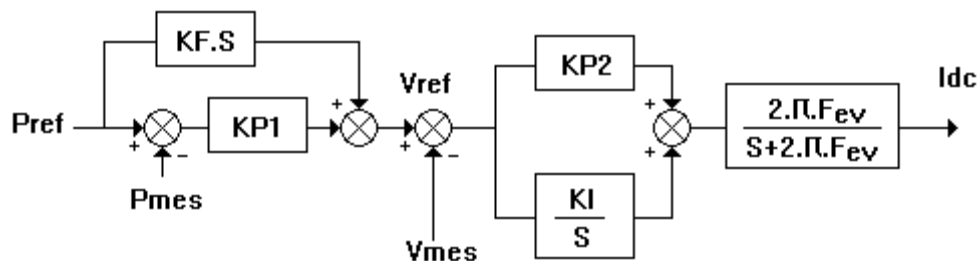

The **Controller parameters** function in the **Advanced functions** menu of the **BPCW** software allows the access to all regulator parameters.

The **Speed error low pass** filter parameter defines the cut-off frequency at - 3 db (F_{ev}) of the 1st order filter acting upon the speed error. The value of this parameter depends on the selected bandwidth.

The **Proportional speed gain** parameter defines the proportional regulator gain ($KP2$) acting upon the speed error. The adjustment range is between 0 and 4 095.

The **Integral 1 speed gain** parameter defines the integral regulator gain (KI) acting upon the speed error. The adjustment range is between 0 and 255.

The **Proportional position gain** parameter defines the proportional gain acting upon the position error ($KP1$). The adjustment range is between 0 and 1.

The **Feedforward position gain** parameter defines the amplitude of the anticipation term (KF) corresponding to the speed input command (position input command derivation). This anticipation term allows to reduce the following error during the motor acceleration and deceleration phases. The adjustment range is between 0 and 1.

All these gain parameters are automatically calculated during the execution of the **AUTOTUNING** function.

4 - POSITION REFERENCE ACQUISITION

The **OFFSET** push button of the slave motor amplifier permits the position reference acquisition of the master motor for an automatic axes alignment after a voltage cutoff. This kind of applications requires TWO **SMT-BD1** amplifiers for the control of both master and slave motors as well as a serial link between the **X5** connectors of both amplifiers.

After the position reference acquisition of the master motor (**OFFSET**), the reference value is automatically stored in the amplifier EEPROM and the automatic alignment mode is activated.

If the procedure has failed because the serial link is not connected or because the amplifier of the master motor is off, the **Busy** fault is displayed and the automatic alignment mode is disabled.

CHAPTER 6 - COMMISSIONING

1 - IMPORTANT WARNING

A master-slave system becomes naturally *unstable* when the slave motor gets the possibility to mechanically drive the master motor, as shown below.

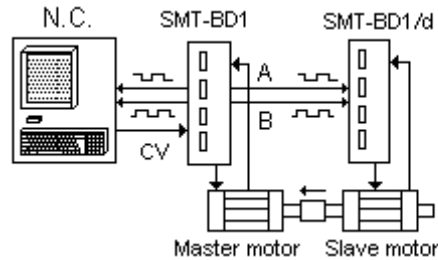

A shift of the slave motor shaft mechanically pushes the master motor which then generates a position input command for the slave motor in its shifting direction. In this case, both motors will race up to the maximum speed of the slave motor. The slave motor has no possibility to control this phenomenon and the system stability entirely depends on the master motor control.

In order to avoid this racing, the slave motor must be enabled after the master motor and the master motor must be able to provide a higher torque than the maximum torque of the slave motor. For reasons of safety, the NC that controls the master motor must be able to detect the system racing (via the master motor position error) and to immediately stop both motors.

Anyway, a master/slave system can correctly work only if there is a certain backlash or elasticity in the mechanical connection between both motors.

2 - CHECKING THE CONFIGURATION

Check the amplifier standard configuration as described in Chapter 6 of the standard **SMT-BD1** manual.

Check for the presence of the **SMT-I1-BD1** or **SMT-I2-BD1** daughter board between both logic and power boards (see chapter 8 (Appendix): Location diagram of the hardware options).

If using an external encoder for the master motor, check that the 5 V jumper is correctly made on the logic board for the encoder supply (see Chapter 8: Location diagram of the hardware options).

3 - POWERING

Turn on the amplifier as described in Chapter 6 of the standard **SMT-BD1** manual.

4 - START AND ADJUSTMENT

Start the amplifier commissioning and adjustment procedure as described in Chapter 6 of the standard **SMT-BD1** manual, by means of the **BPCW** software.

Select the **PI²** speed regulator before executing the **AUTOTUNING** function in the **CONTROLLER** module.

In case of loud noise in the motor at standstill and when running, check the transmission rigidity between motor and load (backlashes and elasticities in gearings and couplings).

If necessary, renew the **AUTO-TUNING** procedure by choosing a lower bandwidth (**Bandwidth = Medium or Low**). If the problem remains, renew the **AUTO-TUNING** procedure by activating the antiresonance filter (**Filter = Antiresonance**). The antiresonance filter is accessible from the **BPCW** software version **2.6** and the amplifier EPROM version **5.7**.

Execute the **MODIFY** function in the **ENCODER RESOLUTION** module and select the **Encoder resolution** parameter (see Chapter 2, part 1 for the limitation of this parameter according to the motor maximum speed).

The gearing ratio between both master and slave motors is equal to the ratio of the following resolutions:

$$\text{Gearing ratio} = \frac{\text{Encoder resolution of the master motor (ppr)}}{\text{Encoder resolution of the slave motor (ppr)}}$$

The maximum speed of the master motor is equal to the ratio between the maximum speed of the slave motor and the gearing ratio between both master and slave motors:

$$\text{Maximum Speed of the master motor (rpm)} = \frac{\text{Maximum Speed of the slave motor (rpm)}}{\text{Gearing ratio}}$$

Execute the **Programmation** function of the **ENCODER RESOLUTION** module in order to confirm the choice of the **Encoder resolution** parameter.

Display the **Indexer / Electronic Gearbox** module accessible in the **Advanced functions** menu.

Select the **Pulse input mode** function in the **Indexer / Electronic Gearbox** module.

Initialize the **Motor deadband** parameter at 0 and the **Following error** parameter at its maximum value, in the **Indexer / Electronic Gearbox** module.

Activate the **ENABLE** input: the motor is controlled at its current position and must follow the input pulses emitted by the master axis. When the amplifier is disabled (**ENABLE** input not activated), the input pulses of the master axis are not counted any more.

Adjust the following error threshold (**Following error**) at its minimum value in order to avoid the **Position** error triggering during the normal duty cycle.

If necessary, enter a position deadband by means of the **Motor deadband** parameter. This will cancel standstill oscillations due to backlashes in the transmissions between motor and load.

Check for the position error value (**Pos err**) during the operation. It is possible, if necessary, to reduce the position error by increasing at first the speed regulator gain by means of the **Stability Gain** function of the Controller module and then the **Proportional position gain** in the **Controller parameters** menu.

Use the amplifier limit switch inputs (**FC+** and **FC-**) for limiting the slave axis displacement, if necessary. If one of the limit switches **FC+** or **FC-** is activated, the slave motor displacement will be stopped in the appropriate direction and the position error between both master and slave motors will quickly increase.

5 - MANUAL ALIGNMENT OF THE SLAVE AXIS

Activate the **ENABLE** input: the slave motor is controlled at its usual position and follows the input pulses emitted by the master axis.

Use the **JOG+** and **JOG-** inputs for entering a shift between both master and slave motors. These inputs are connected to two push buttons and allow to displace the slave motor of one encoder edge (a quarter of an encoder pulse of the motor resolution) in the positive or negative direction at each activation of **JOG+** or **JOG-**. If one of the push buttons is constantly activated, the slave motor runs at constant speed in the appropriate direction.

6 - AUTOMATIC ALIGNMENT OF THE SLAVE AXIS

This kind of application requires TWO **SMT-BD1** amplifiers: one for the control of the slave motor and one for the control of the master motor.

Start and adjust the master motor amplifier as usually by means of the **BPCW** software and save the adjustment parameters (**Save parameters to EEPROM**) before leaving the software (**Exit**).

Start and adjust the slave motor amplifier as described above (Chapter 6, paragraph 4) by means of the parameter setting **BPCW** software.

Adjust the value of the **Alignment speed** parameter in the **Indexer / Electronic gearbox** module accessible in the **Advanced functions** menu for the slave motor.

Save the adjustment parameters (**Save parameters to EEPROM**) before leaving the software (**Exit**).

Use the **OFFSET** push button of the slave motor amplifier in order to disable the automatic alignment mode. In this case, the **Busy** error is displayed on the front panel.

Connect the amplifiers of both master and slave motors via the serial link according to the wiring diagram below (the amplifiers must be disabled).

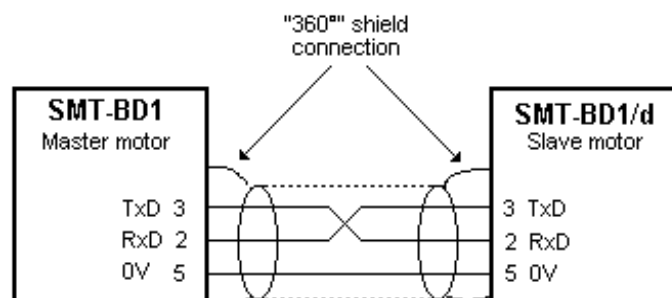

Turn on both amplifiers, with the **ENABLE** inputs not activated (disabled).

CAUTION: When putting the slave motor under control (**ENABLE** input activated), the automatic alignment may generate a maximum rotation of half a revolution, if the mode is not disabled.

Make a manual alignment of the slave motor with regard to the master motor (by manually moving the shafts when they are free, or with the **JOG+** and **JOG-** inputs when enabled).

When *both master and slave motors are brought into line*, use the **OFFSET** push button of the slave axis amplifier in order to make the position reference acquisition and activate the automatic alignment mode.

CAUTION: The motors must be stopped when making the position reference acquisition.

When the automatic alignment mode is enabled, the slave motor automatically lines up on the master motor reference position each time the slave motor *is enabled*. For a correct alignment, the shift between both motors must remain less than half a revolution while the slave amplifier is disabled.

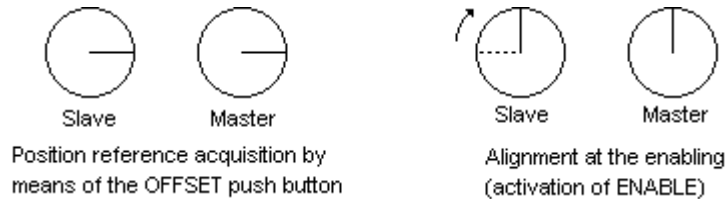

After a *voltage cutoff*, the slave motor automatically lines up on the master motor reference position if the following requirements are answered:

- The X5 serial link between both amplifiers must be connected when turning power on.
- If both amplifiers are not in the same rack, the master motor amplifier must be powered before the one of the slave motor.

If these requirements are not answered:

- The **Position** fault will be continuously displayed after enabling the slave motor amplifier, indicating that the automatic initialization has failed.
- The slave motor will be controlled at its usual position at each enabling.

IMPORTANT NOTE

In order to get an absolute alignment between both master and slave motors after a voltage cutoff, the shift between both disabled motors must remain less than half a revolution.

For a correct alignment, the master motor must be stopped during the automatic initialization of the slave motor. In this case, the amplifier control can be made with a relay logic, as shown below: the **ENABLE** input of the master amplifier is disabled as long as the **AMP READY** contact of the slave motor is open.

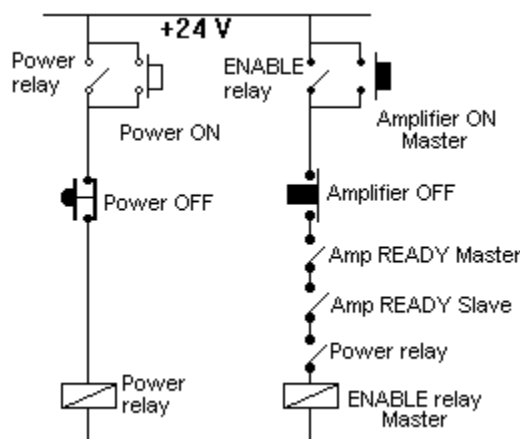

IMPORTANT

In multi-axes applications where several slave motors are running, the axes alignment at power on is achieved by the host control system via the serial link RS232/485 (see manual "Parameter Setting Instructions", version 1.1).

7 - MASTER/SLAVE SYNCHRONIZATION USING THE ANALOGUE INPUT COMMAND

This solution is only suitable when the following error between the axes, which is due to the response time of the slave motor during the deceleration and acceleration phases (very high dynamic performances), must be reduced. The **SMT-BD1** amplifiers must both be equipped with the **X.XC** firmware EPROM (with same version number). The configuration of this kind of application is shown below.

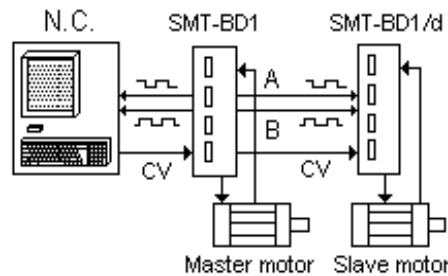

The analogue speed input command CV generated by the NC controlling the master axis enters the **X4** connectors of both master and slave amplifiers. The slave amplifiers cancels the position following between both motors according to the incremental position value of the master motor received via the **X2** position connector. The structure of the slave amplifier speed and position regulator is shown below.

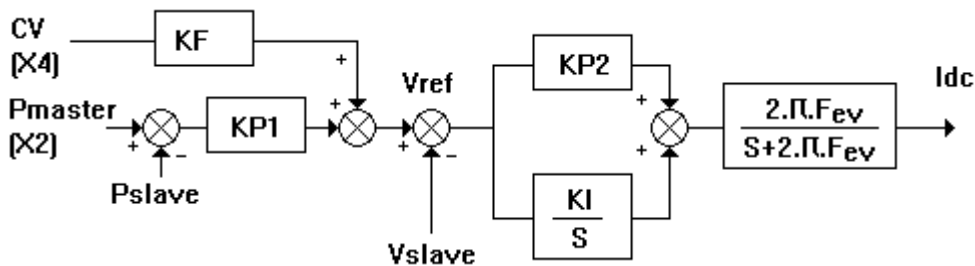

After the starting of the master/slave system as described above, the procedure is the following:

A) Choose the parameters "**Maximum speed**" and "**Encoder resolution**" for both master and slave amplifiers, according to the gearing ratio.

$$\text{Gearing ratio} = \frac{\text{Encoder resolution "master motor"} \cdot \text{Maximum Speed "slave motor"}}{\text{Encoder resolution "slave motor"} \cdot \text{Maximum Speed "master motor"}}$$

Initialize the **Accel/Decel time** parameter at 0 for both master and slave amplifiers.

Choose the **Analogue input filter** parameters that must be identical for both master and slave amplifiers.

B) Connect the analogue speed input command **CV** of the master amplifier with the slave amplifier (pins 15,16 and 17 of **X4**) according to the wiring recommendations.

C) Disable the function "**Pulse input mode**" in the module **Indexer / Electronic Gearbox** of the **BPCW** software for the slave amplifier.

Short-circuit the analogue speed input command **CV** connected on both amplifiers or display a zero speed input command in the NC if you want to compensate the offset of the system amplifier + NC.

Execute the offset compensation procedure on both amplifiers by means of the push button **OFFSET** on the amplifier front panel.

Select again the function "**Pulse input mode**" in the module **Indexer / Electronic Gearbox** for the slave amplifier.

CAUTION: If the offsets of both amplifiers are not correctly compensated, this will involve a position error between both slave and master motors.

D) Enable the logic input **SCV** on the slave amplifier connector **X2** for the synchronization by using the analogue speed input command. The connection of this optocoupled input in positive logic is shown below. The input voltage for the level 1 is between 5 V and 24 V.

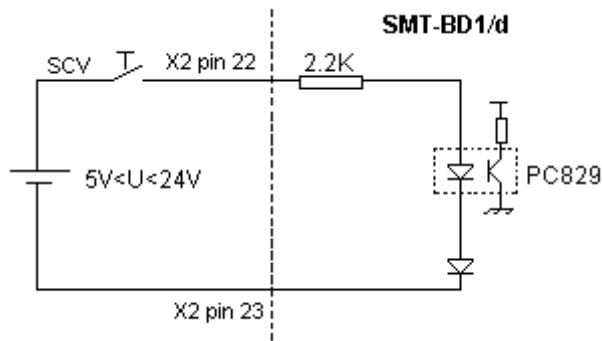

E) Adjust the parameter "**Following error**" to its desired value in order to disable the slave amplifier if the alignment shift between both axes is too large.

CAUTION: The slave amplifier **ENABLE** input must be enabled when the speed input command **CV** is zero. The speed input command can only be entered when both motors are controlled (master and slave **ENABLE** inputs enabled). When the master motor is disconnected (by disabling the **ENABLE** input or by a stored fault), the analogue input command remains for the slave motor.

Note: The case where both master and slave axes are identical (amplifier, motor and load sizes) provides the best results when both master and slave amplifier speed loops have the same adjustment (gains and input command filter).

CHAPTER 7 - FAULT FINDING

1 - "POSITION" FAULT

Check that the limit switches **FC+** and **FC-** are not activated.

Increase the value of the **Following Error** parameter in the **Indexer / Electronic Gearbox** menu accessible via the **Advanced Function** module.

Check that the slave motor speed does not reach the maximum speed defined by the **Maximum Speed** parameter of the **Analogue Input** module. Otherwise, increase the maximum slave motor speed defined by the **Maximum Speed** parameter or reduce the master axis speed.

Check that the current input command **IDC** of the slave motor does not reach the maximum value defined in the **Maximum current** parameter of the **Current** module. Otherwise, increase the **Maximum Current** parameter of the slave motor or increase the acceleration and deceleration times of the master motor.

2 - "BUSY" FAULT

If this fault occurs during the position reference acquisition of the master motor by means of the **OFFSET** push button:

- Check that the serial link is correctly connected between the **X5** connectors of both master and slave motors,
- Check that the master amplifier is on.
- If the fault still remains, switch off the amplifier (before saving the parameters to the EEPROM) and try again the position reference acquisition.

If this fault occurs when turning on the amplifier in automatic alignment mode:

- Check that the serial link is correctly connected between the **X5** connectors of both master and slave amplifiers,
- Check that the master amplifier is on.

3 - OPERATION PROBLEMS

3.1 - LOUD CRACKLING NOISE IN THE MOTOR AT STANDSTILL

Check that the Motor-Amplifier-Resolver ground connections answer the requirements in Chapter 4.

Check that the wiring of the incremental position input command answers the requirements in Chapter 4.

3.2 - LOUD NOISE IN THE MOTOR AT STANDSTILL AND WHEN RUNNING

Check for the rigidity of the mechanical coupling between motor and load (backlashes and elasticities in the gearboxes and couplings).

Execute the **AUTO-TUNING** function again by selecting a lower bandwidth (**Medium** or **Low**).

If the problem remains, renew the **AUTO-TUNING** procedure by activating the antiresonance filter (**Filter = Antiresonance**). The antiresonance filter is accessible from the **BPCW** software version **2.6** and the amplifier EPROM version **5.7**.

3.3 - LOUD NOISE IN THE MOTOR WHEN RUNNING

Select the highest position resolution on the slave motor (**Encoder resolution**) according to the maximum rotation speed (see chart of Chapter 5, paragraph 2). It is also necessary to modify the master motor resolution in order to keep the reduction ratio.

3.4 - MOTOR POSITION OSCILLATION AT STANDSTILL

Check for the rigidity of the mechanical coupling between motor and load (backlashes and elasticities in the gearboxes and couplings).
Increase the value of the **Motor Dead band** parameter in the **Indexer / Electronic Gearbox** menu accessible via **Advanced Function**.

CHAPTER 8 - APPENDIX

LOCATION DIAGRAM OF THE HARDWARE OPTIONS

