

This manual describes the **option "j"** of the **SMT-BD1** amplifier: **Accumulator control of unwind / rewind systems.**

The general information about the digital amplifier commissioning are described in the standard **SMT-BD1** manual. This manual may be used in conjunction with appropriate and referenced drawings pertaining to the various specific models.

Maintenance procedures should be attempted only by highly skilled technicians (EN 60 204.1 standard) using proper test equipment.

The conformity with the standards and the "CE" approval are only valid if the items are installed according to the recommendations of the racks and amplifiers manuals.

Any contact with electrical parts, even after power down, may involve physical damage.

Wait for 30 seconds after power down before handling the rack or the amplifiers (residual voltage).

INFRANOR does not assume any responsibility for any physical or material damage due to improper handling or wrong descriptions of the ordered items.

Infranor reserves the right to change any information contained in this manual without notice.

This manual is a translation of the original document and does not commit INFRANOR's responsibility. The french manual is the only reference document.

OPTION "j"

ACCUMULATOR CONTROL OF WINDING/UNWINDING SYSTEMS

CONTENTS

CHAPTER 1 - GENERAL DESCRIPTION	5
CHAPTER 2 - SPECIFICATIONS	6
1 - MAIN TECHNICAL DATAS.....	6
2 - AMPLIFIER BLOCK DIAGRAM	7
CHAPTER 3 - INPUTS - OUTPUTS.....	8
1 - X4 COMMAND CONNECTOR	8
2 - SPECIFICATIONS OF THE INPUTS / OUTPUTS.....	9
2.1 - Analog inputs	9
2.2 - Logic inputs/outputs.....	10
3 - TEST CONNECTOR	10
CHAPTER 4 - CONNECTIONS.....	11
1 - CONNECTION DIAGRAM	11
2 - MANDATORY WIRING	11
CHAPTER 5 - ADJUSTABLE PARAMETERS	13
1 - OPERATION MODE	13
2 - APPLICATION PARAMETERS	14
3 - REGULATOR PARAMETERS.....	15
CHAPTER 6 - COMMISSIONING.....	16
1 - CHECKING THE CONFIGURATION	16
2 - APPLYING POWER.....	16
3 - STARTING AND ADJUSTMENT	16
3.1 - Adjustments with empty spool.....	16
3.2 - Adjustments with full spool	17
3.3 - Starting the unwind/rewind system	17
CHAPTER 7 - FAULT FINDING.....	18
1 - LOUD CRACKLING NOISE IN THE MOTOR AT STANDSTILL	18
2 - LOUD NOISE IN THE MOTOR AT STANDSTILL AND WHEN RUNNING.....	18
3 - LOUD NOISE IN THE MOTOR WHEN RUNNING.....	18

CHAPTER 1 - GENERAL DESCRIPTION

The accumulator control for winding/unwinding systems requires the **SMT-BD1** amplifier to be equipped with the **X.X 7** EEPROM version. In this configuration, the **SMT-BD1/j** amplifier controls the speed of the motor driving the spool according to the material line speed and the spool diameter. The accumulator height is directly proportional to the line speed in order to allow the material storage and restitution during the spool deceleration and acceleration phases. The accumulator height measurement is received by the amplifier as an analog voltage between 0 V and + 10 V or between 0 V and - 10 V. The spool diameter measurement is also received by the amplifier as an analog voltage between 0 V and + 10 V or between 0 V and - 10 V. These signals are entered on the amplifier command connector **X4**. The system structure is described below.

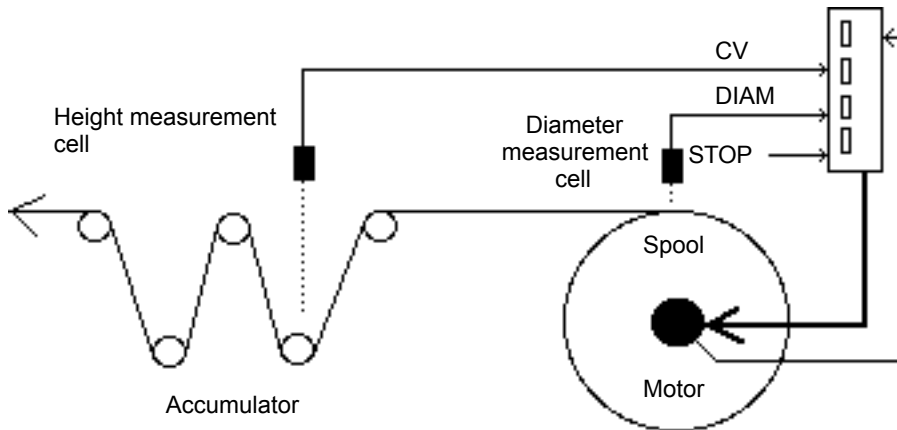

The maximum motor rotation speed corresponds to the minimum spool diameter and is adjustable from 100 rpm to 14000 rpm.

The ratio between both maximum and minimum spool diameters is adjustable from 1 to 100.

The motor speed is continuously adjusted in the amplifier according to the material line speed (Motor speed = Accumulator height / Spool diameter). A **P** or **PI** speed regulator continuously adjusts the motor speed to the input command value calculated according to the accumulator height measurement and the spool diameter measurement. The speed regulator gains are automatically matched according to the spool diameter in order to keep the dynamic performances of the control in all load conditions.

The programming, in the amplifier, of the accumulator standstill position allows to obtain an automatic material rewind when enabling the spool, if the logic input **REW** is activated.

The sizing, in the amplifier, of the spool diameter measurement and the accumulator height measurement allows an easy adjustment to various sensor types.

In case of material breaking or accumulator blocking in high position, activating the logic input **STOP** allows to stop the spool with the whole available braking torque.

The **REV** logic input allows to reverse the motor rotation direction in case of a modification of the unwind/rewind configuration.

CHAPTER 2 - SPECIFICATIONS

1 - MAIN TECHNICAL DATAS

Accumulator height measurement	Analog input 0 V to + 10 V or 0 V to - 10 V Resolution: 11 bit as standard (15 bit optional) Low-pass filter with adjustable frequency
Spool diameter measurement	Analog input 0 V to + 10 V or 0 V to - 10 V Resolution: 11 bit as standard (15 bit optional) Low-pass filter: 1 Hz
Spool ratio = max. diameter / min. diameter	Adjustable parameter from 1 to 100 Resolution: 1/256
P or PI speed regulator	Sampling period: 0,5 ms Auto-tuning at setup Anti-resonance filter Automatic Gains-Spool diameter matching
Speed loop bandwidth	Adjustable cut-off frequency: 50, 75 or 100 Hz
Height measurement sizing	Accumulator standstill position and active position sensor voltage adjustable from 0 V to 10 V
Spool diameter sizing	Minimum and maximum spool diameter sensor voltage adjustable from 0 V to 10 V
Spool accel./decel. ramp	Adjustable parameter from 0 s to 30 s between 0 and maximum line speed
Logic inputs	STOP: Spool stop REV: Rotation reversal REW: Accumulator rewind
Logic outputs	I DYN: I ² t warning AOK: Amplifier OK

2 - AMPLIFIER BLOCK DIAGRAM

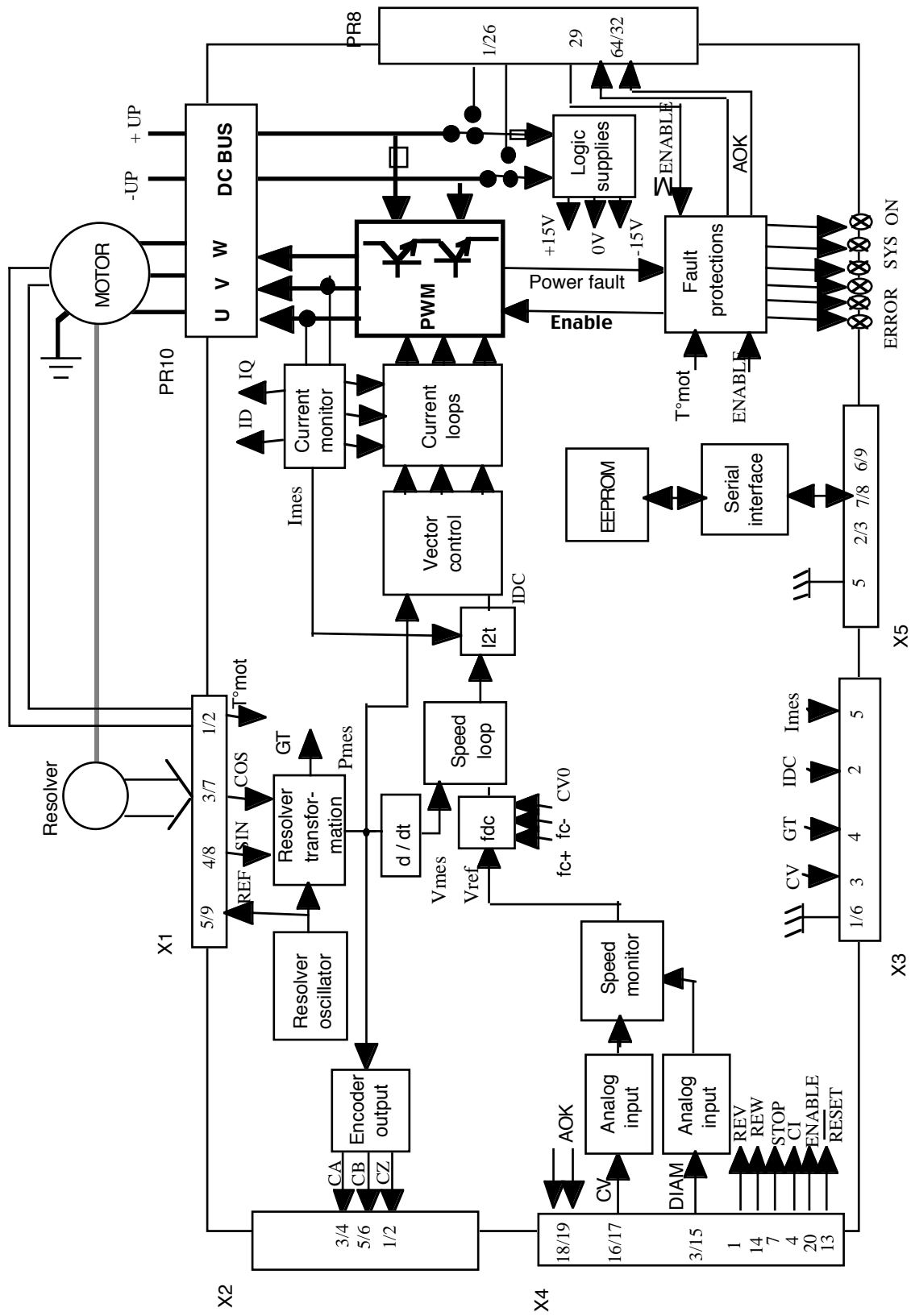

CHAPTER 3 - INPUTS - OUTPUTS

1 - X4 COMMAND CONNECTOR

Pin	Function	I / O	REMARKS
1	REV Rotation reversal	I	Positive or negative logic (see standard manual SMT-BD1)
14	REW Accumulator rewind	I	Positive or negative logic (see standard manual SMT-BD1)
24	Logic input 0 Volt	I	
20	ENABLE	I	Positive or negative logic (see standard manual SMT-BD1)
23	ENABLE 0 Volt	I	
4	CI current control	I	Positive or negative logic (see standard manual SMT-BD1)
7	STOP spool stop	I	Positive or negative logic (see standard manual SMT-BD1)
25	Logic input 0 Volt	I	
13	Amplifier fault RESET	I	Resets amplifier via 0 V (contact between 13 and 12)
12	RESET input 0 Volt	I	
17	Height measurement CV+	I	Differential input of accumulator height measurement
16	Height measurement CV-	I	between 0 V and +10V and 0 V and -10 V
3	Diameter measurement DIAM	I	Spool diameter measurement input between 0 V and + 10 V or 0 V and - 10 V
15	Analog input 0 Volt	I	
10	Speed monitor output	O	± 8 V for ± 14000 rpm; linearity = 10 %; max. load: 10 mA
2	Current monitor output	O	± 10 V; resolution: 8 bits; load: 10 mA; (DAC out 2)
11	Analog output 0 Volt	O	10 V for amplifier current rating
8, 9	I dyn warning of I ² t	O	Relay contact: open if I dyn threshold is reached Pmax = 10 W with Umax = 50 V or Imax = 100 mA
18, 19	Amp. Ready	O	Relay contact: closed if amplifier OK, open if fault. Pmax = 10 W with Umax = 50 V or Imax = 100 mA
21	+ 15 V	O	Max. 50 mA available
22	- 15 V	O	Max. 50 mA available
5, 6	non connected		

2 - SPECIFICATIONS OF THE INPUTS / OUTPUTS

2.1 - ANALOG INPUTS

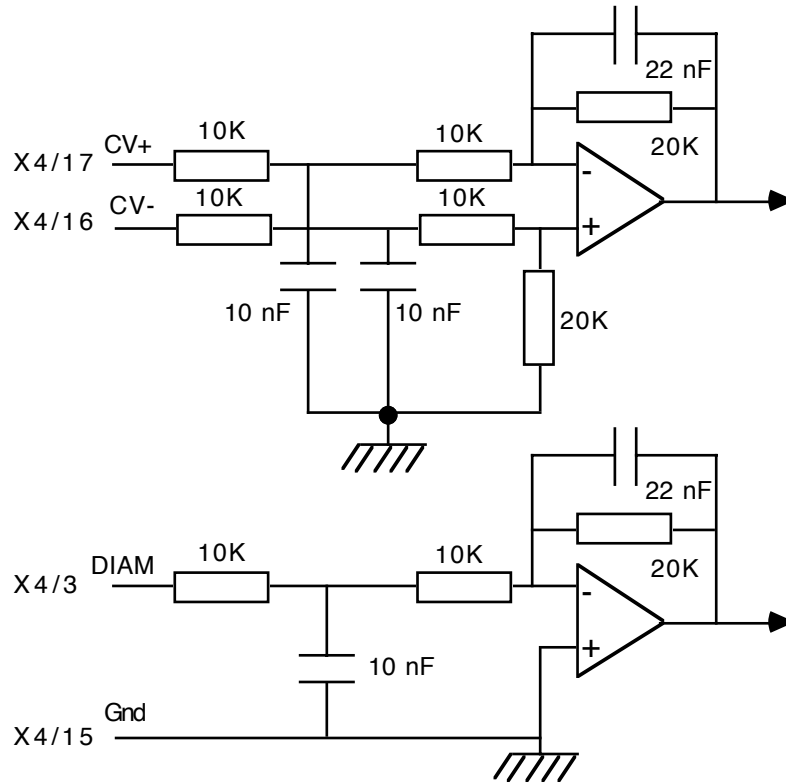

2.2 - LOGIC INPUTS/OUTPUTS

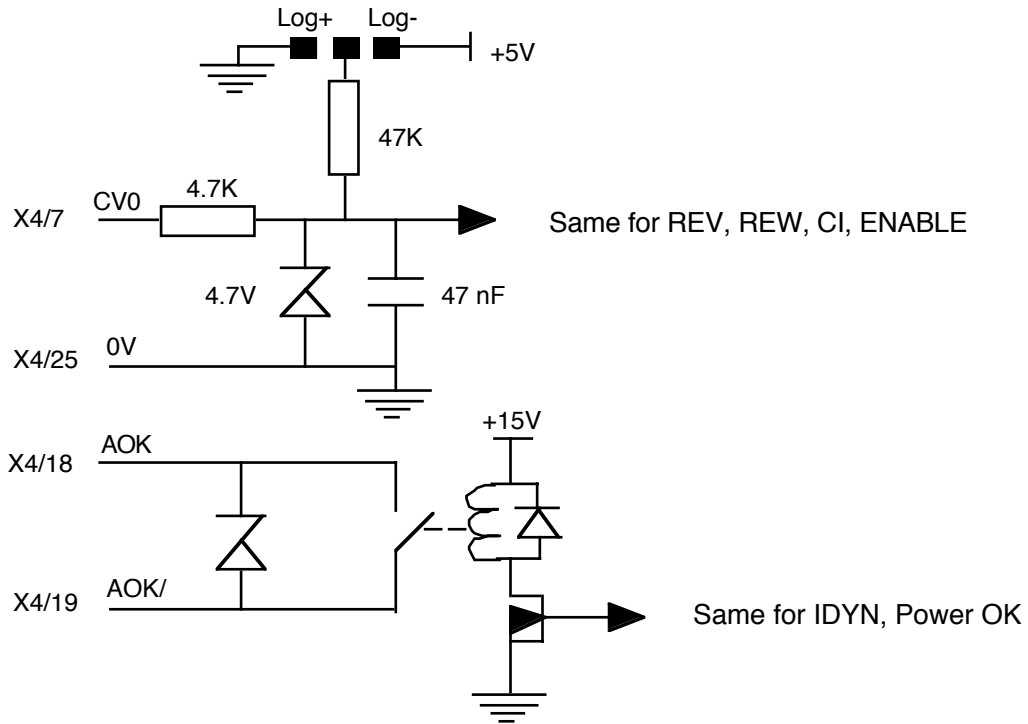

3 - TEST CONNECTOR

Pin	Function	CHARACTERISTICS
1 - 6	0 V	
2	DAC 1 output	+/- 10 V, resolution: 8 bit, linearity: 2 % (IDC, Imon, ID, IQ, Vref, Vmon)*
3	Speed input command CV	+/- 10 V for +/- max. speed
4	Speed signal GT	+/- 8 V for +/- 14 000 rpm
5	DAC 2 output	+/- 10 V, resolution: 8 bit, linearity: 2 % (IDC, Imon, ID, IQ, Vref, Vmon)*

* See manual "**BPCW** Options", part "Digital oscilloscope".
 Linearity = 10 % on logic boards 01612A, 01612B and 01612C.

CHAPTER 4 - CONNECTIONS

1 - CONNECTION DIAGRAM

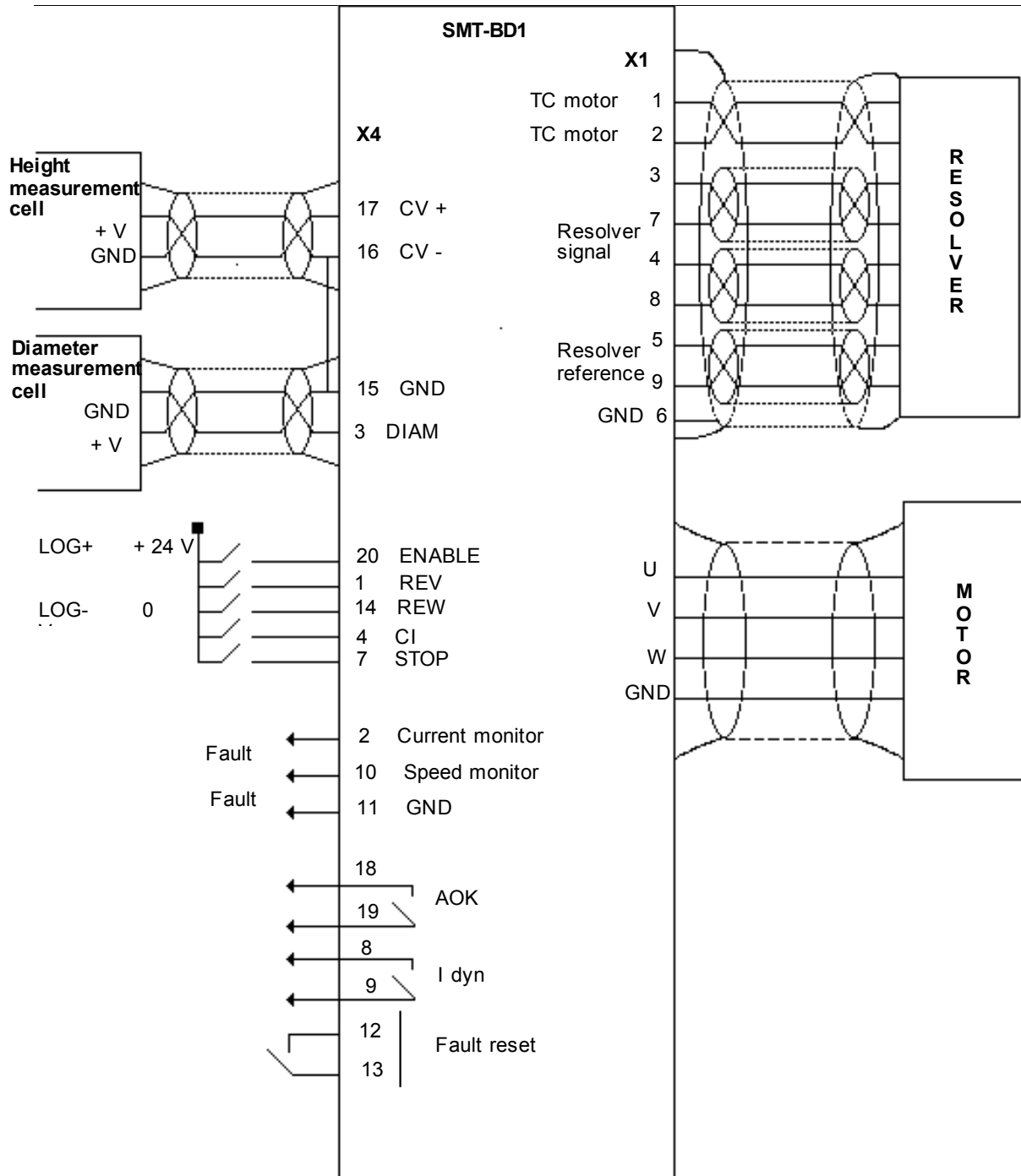

2 - MANDATORY WIRING

It is mandatory to use a pair twisted shielded cables for the analog signals CV and DIAM. Cable ends must have a 360° shield connection by means of the metallic connectors at both cable ends. Otherwise, make a connection as short as possible only at the end on amplifier side with a 0 V pin of the X4 connector (see SMT-BD1 standard manual).

The analog signals (CV and DIAM) must be wired according to the polarities between the sensor cells and the amplifier (CV+ and DIAM on diff. high of the cells), and the amplifier 0 Volt MUST be connected to the cells 0 Volt by means of a cable (pins 15 and 16 must be connected together on the X4 connector at the amplifier end). If necessary, the motor rotation direction can be reversed in the amplifier (see SMT-BD1 standard manual).

CHAPTER 5 - ADJUSTABLE PARAMETERS

The parameters used for the unwind/rewind control are accessible via the **Accumulator control** and **Diameter adaptive gain** submenus of the **Advanced functions** menu, in the **BPCW** software version 2.54 and higher.

ACCUMULATOR CONTROL PARAMETERS	
<input checked="" type="checkbox"/> ENABLE ACCUMULATOR CONTROL	
SPOOL DIAMETER RATIO (MAX/MIN)	<input style="width: 50px;" type="text" value="1"/>
<input style="width: 100%;" type="text" value="DIAMETER SENSOR ACQUISITION (V)"/>	<input style="width: 50px;" type="text" value="0"/>
EMPTY SPOOL DIAMETER SENSOR VALUE (V)	<input style="width: 50px;" type="text" value="0"/>
FULL SPOOL DIAMETER SENSOR VALUE (V)	<input style="width: 50px;" type="text" value="10"/>
<input style="width: 100%;" type="text" value="ACCUMULATOR SENSOR ACQUISITION (V)"/>	<input style="width: 50px;" type="text" value="0"/>
ACCUMULATOR SENSOR VALUE AT STANDSTILL (V)	<input style="width: 50px;" type="text" value="0"/>
ACCUMULATOR SENSOR VALUE FOR MAX SPEED (V)	<input style="width: 50px;" type="text" value="10"/>
<input style="margin: 5px 10px;" type="button" value="EXIT"/> <input style="margin: 5px 10px;" type="button" value="HELP"/> <input style="margin: 5px 10px;" type="button" value="VALIDATE"/>	

DIAMETER ADAPTIVE GAIN	
SPEED REGULATOR GAIN RATIO (MAX/MIN)	<input style="width: 50px;" type="text" value="1"/>
DIAMETER SENSOR VALUE FOR MAX GAIN (V)	<input style="width: 50px;" type="text" value="10"/>
<input style="margin: 5px 10px;" type="button" value="EXIT"/> <input style="margin: 5px 10px;" type="button" value="HELP"/> <input style="margin: 5px 10px;" type="button" value="VALIDATE"/>	

1 - OPERATION MODE

The operation in unwind/rewind accumulator control is selected by the **Enable accumulator control** function of the **Accumulator control parameters** submenu of the **Advanced functions** menu.

This mode corresponds to the motor speed control with a **P** or **PI** regulator. The motor speed input command is calculated according to the accumulator height measurement and the spool diameter measurement in order to keep the accumulator height proportional to the material line speed.

2 - APPLICATION PARAMETERS

The following parameters are accessible in the **ANALOG INPUT** module of the **BPCW** software.

The parameter **Maximum speed (rpm)** defines the maximum motor rotation speed (MS) that corresponds to the maximum material line speed value and to the minimum spool diameter value. The adjustment range is between 100 and 14 000 rpm.

The **Accel/Decel time (s)** parameter defines the spool acceleration and deceleration time between 0 and the maximum material line speed value (positive accumulator position). The adjustment range is between 0 and 30 seconds.

The function **Reverse movement** reverses the motor rotation direction with regard to the CV input voltage (accumulator height). The drawing below shows the standard MAVILOR motors configuration according to the wiring defined by the manufacturer.

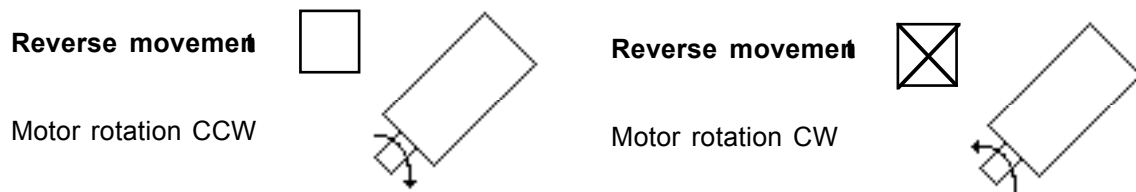

The following parameters are accessible via the **Accumulator control parameters** submenu of the **Advanced functions** menu.

The **Spool diameter ratio (Max/Min)** parameter defines the ratio (SDR) between both maximum and minimum diameters of the spool to be unwinded. The adjustment range is between 1 and 100.

The **Diameter sensor acquisition (V)** allows the reading of the voltage given by the diameter sensor. The reading range is between 0 V and 10 V.

The parameter **Empty spool diameter sensor value (V)** defines the voltage value (ESDSV) provided by the diameter sensor when the spool is empty (minimum diameter). The adjustment range of this parameter is between 0 V and 10 V.

The parameter **Full spool diameter sensor value (V)** defines the voltage value (FSDSV) provided by the diameter sensor when the spool is full (maximum diameter). The adjustment range of this parameter is between 0 V and 10 V.

These parameters allow the easy sizing of the spool diameter measurement signal **DIAM** as shown below.

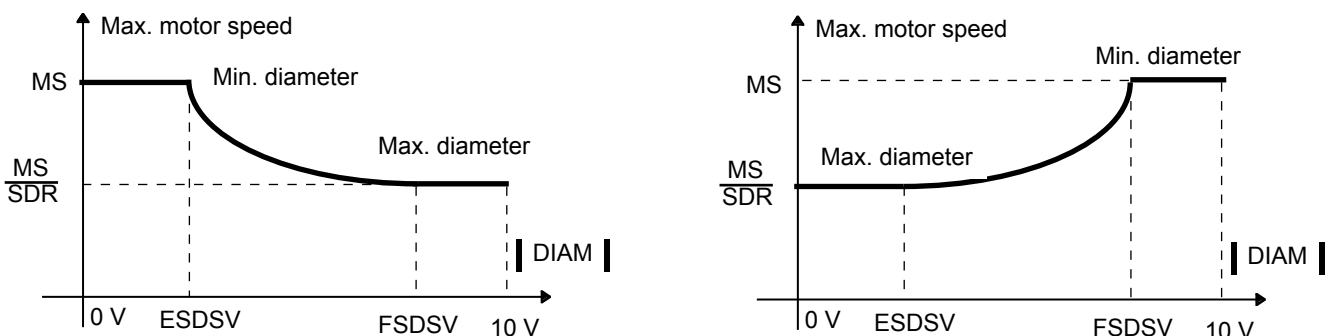

The **Accumulator sensor acquisition (V)** allows the reading of the voltage given by the accumulator sensor. The reading range is between 0 V and 10 V.

The **Accumulator sensor value at standstill (V)** defines the voltage value in Volts (ASV0) provided by the accumulator height sensor when the material line speed is equal to zero (accumulator standstill position). The reading range is between 0 V and 10 V.

The **Accumulator sensor value for max. speed (V)** defines the voltage value in Volts (ASVM) provided by the accumulator height sensor at maximum material line speed is equal to zero (accumulator active position). The reading range is between 0 V and 10 V.

These parameters allow the easy sizing of the accumulator height measurement signal **CV** as shown below.

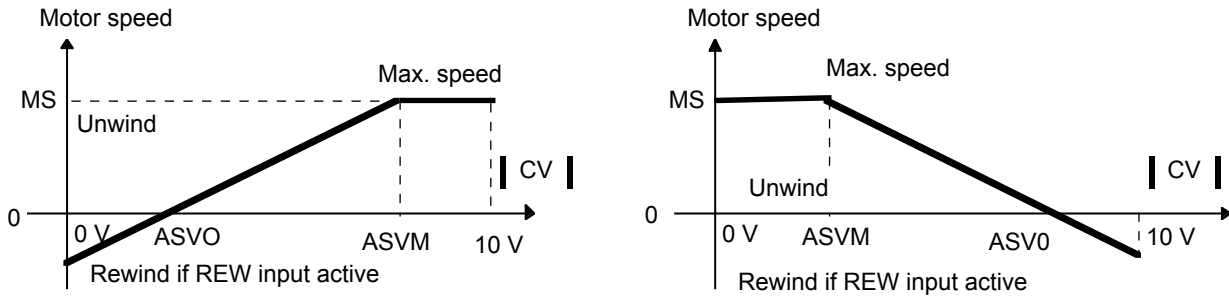

3 - REGULATOR PARAMETERS

The speed regulator structure is shown below:

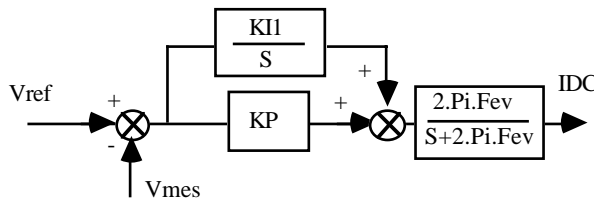

The gain parameters are automatically calculated during the **AUTO-TUNING** procedure and are accessible via the submenu **Controller parameters** of the menu **Advanced Functions**.

The parameter **Speed error low-pass filter** defines the cut-off frequency at - 3 db (Fev) of the first order filter acting on the speed error. The value of this parameter depends on the selected bandwidth.

The parameter **Proportional speed gain** defines the proportional gain (KP) of the regulator acting on the speed error. The adjustment range is between 0 and 4 095.

The parameter **Integral 1 speed gain** defines the integral gain (K11) of the regulator acting on the speed error. The adjustment range is between 0 and 255.

The gain adjustment parameters according to the spool diameter are accessible via the submenu **Diameter adaptive gain** of the menu **Advanced functions**.

The parameter **Diameter sensor value for maximum gain (V)** defines the voltage in Volts (DSVMG) provided by the diameter sensor, at which the speed regulator gain is the highest. The adjustment range is between 0 V and 10 V.

The parameter **Speed regulator gain ratio (Max/Min)** defines the ratio between the maximum speed regulator gain corresponding to the parameter **Diameter sensor value for maximum gain (V)** and the minimum speed regulator gain corresponding to the parameter **Empty spool diameter sensor value (V)**. The adjustment range of this parameter is between 1 and 1000.

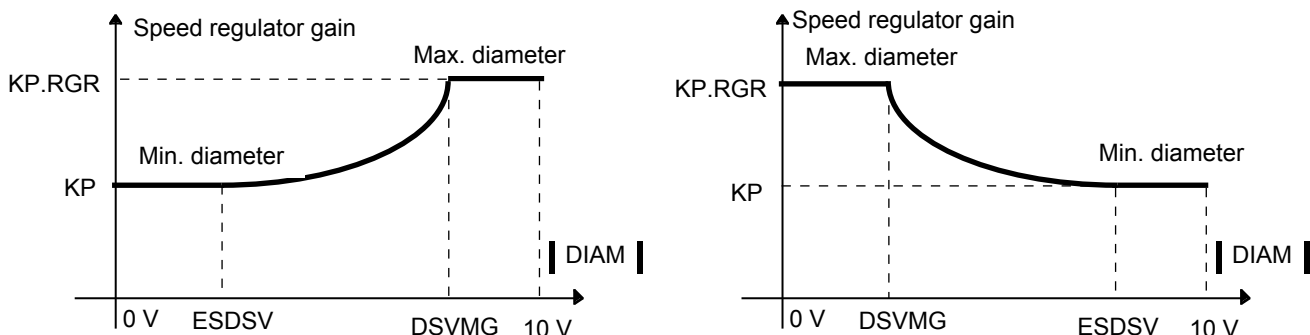

CHAPTER 6 - COMMISSIONING

1 - CHECKING THE CONFIGURATION

Check the amplifier standard configuration as described in Chapter 6 of the standard **SMT-BD1** manual.

Check for the version of the firmware memory that must be **X.X7**.

2 - APPLYING POWER

Turn on the amplifier as described in Chapter 6 of the standard **SMT-BD1** manual.

3 - STARTING AND ADJUSTMENT

Start and adjust the amplifier by means of the **BPCW** software, as described in Chapter 6 of the standard **SMT-BD1** manual.

3.1 - ADJUSTMENTS WITH EMPTY SPOOL

Enter the maximum motor speed corresponding to the empty spool in the box **Rated speed** of the **Analog input** module of **BPCW** by selecting **Reference voltage = 10 V**. This speed is calculated according to the minimum spool diameter and the maximum accumulator height corresponding to the maximum material line speed.

Enter the ratio value **Spool diameter ratio (Max/Min)** between both maximum and minimum diameters of the spool to be unwinded in the module **Accumulator control parameters** of the **Advanced Functions** menu.

Put on the spindle an empty spool corresponding to the minimum diameter and check that the motor shaft free rotation is not dangerous for operator and machine.

Select the function **Enable accumulator control** in the module **Accumulator control parameters**.

Execute the **AUTO-TUNING** procedure in the **CONTROLLER** module for calculating the regulator gains.

*Important remark: The **AUTO-TUNING** procedure must always be executed with an empty spool that corresponds to the minimum inertia reflected to the motor shaft.*

In case of loud noises in the motor at standstill and when running, check the transmission rigidity between motor and load (backlashes and elasticities in gearboxes and couplings). If necessary, execute again the **AUTO-TUNING** procedure by selecting a lower bandwidth (**Bandwidth = Medium or Low**). If the problem remains, renew the **AUTO-TUNING** function by activating the antiresonance filter (**Filter = Antiresonance**). The antiresonance filter is accessible in the **BPCW** software version 2.6 and higher and the amplifier EPROM version 5.7 and higher.

For using a proportional speed regulator (**P**), cancel the parameter **Integral 1 speed gain** in the module **Controller parameters** of the menu **Advanced functions**.

Lock the accumulator at its standstill position and read the voltage value provided by the height sensor (**CV** input) by using the push button **Accumulator sensor acquisition** and enter this value in the parameter box **Accumulator sensor value at standstill**.

Lock the accumulator at its active position corresponding to the maximum material line speed and read the voltage value provided by the height sensor (**CV** input) by using the push button **Accumulator sensor acquisition** and enter this value in the parameter box **Accumulator sensor value for maximum speed**.

Check the motor rotation direction with regard to the voltage provided by the accumulator height sensor. If necessary, change the motor rotation direction by means of the **Reverse movement** function accessible in the **Analog input** module.

Read the voltage value provided by the diameter sensor (**DIAM** input) by using the push button **Diameter sensor acquisition** and enter this value in the parameter box **Empty spool diameter sensor value**.

3.2 - ADJUSTMENTS WITH FULL SPOOL

Put on the spindle a full spool corresponding to the maximum diameter and check that the motor shaft free rotation is not dangerous for operator and machine.

Read the voltage value provided by the diameter sensor (**DIAM** input) in the module **Accumulator control parameters** by using the push button **Diameter sensor acquisition** and enter this value in the parameter box **Full spool diameter sensor value** and then in the box **Diameter sensor value for maximum gain** of the module **Diameter adaptive gain**.

Enable the motor and check its stability. In case of loud noises in the controlled motor, remove the full spool and re-engage the empty one. Then, renew the **AUTO-TUNING** procedure by selecting a lower bandwidth (**Bandwidth = Medium** or **Low**). If the problem remains, renew the **AUTO-TUNING** procedure by activating the antiresonance filter (**Filter = Antiresonance**).

Increase progressively the parameter **Speed regulator gain ratio (Max/Min)** in the module **Diameter adaptive gain** up to the maximum possible value without noises in the motor. Do not exceed the limit value calculated by the ratio between both full and empty spool inertias reflected to the motor shaft (J_{max} motor / J_{min} motor). If it is not possible to enough increase the parameter **Speed regulator gain ratio (Max/Min)** in order to get the desired stability, remove the full spool and re-engage the empty one and renew the **AUTO-TUNING** procedure by activating the antiresonance filter (**Filter = Antiresonance**).

If necessary, initialize the **Accel/decel time (s)** parameter in order to limit the spool acceleration between 0 and the maximum material line speed (high accumulator position).

Check the adjustment stability over the whole spool speed range up to the maximum line speed value provided by the accumulator height sensor (**CV** input).

Enter the value of the parameter **Diameter sensor value for maximum gain (V)** in the module **Diameter adaptive gain** in order to define accurately the gain adjustment range according to the spool diameter. This parameter must be reduced when the value of the parameter **Speed regulator gain ratio (Max/Min)** adjusted before remains quite below the ratio between both full and empty spool inertias reflected on the motor shaft (J_{max} motor / J_{min} motor). This parameter can be calculated as follows:

$$\begin{aligned}
 \text{Diameter sensor value for maximum gain (V)} &= \text{Empty spool diameter sensor value (V)} \\
 &+ \\
 &[\text{Full spool diameter sensor value (V)} - \text{Empty spool diameter sensor value (V)}] \\
 &\times \\
 &[(\text{Speed regulator gain ratio (Max/Min)} - 1) \times (J_{min} \text{ motor} / J_{max} \text{ motor})]^{0,25}
 \end{aligned}$$

3.3 - STARTING THE UNWIND/REWIND SYSTEM

Engage the material in the accumulator and then in the system downstream of the unwind/rewind system.

Enable the motor and re-adjust, if necessary, the accumulator height in standstill position by means of the parameter **Accumulator sensor value at standstill**. The automatic material rewind can be activated by the logic **REW** input.

Increase progressively the material line speed in order to check the correct unwind/rewind operation over the whole speed range.

In case of a noisy accumulator height measurement signal, reduce the value of the **Analog input low pass filter** parameter in the **Advanced functions** menu of **BPCW**.

If necessary, wire the logic input **STOP** in order to stop the spool with the maximum torque available on the motor in both rotation direction in case of emergency.

Select the function **Save parameters to EEPROM** function before quitting **BPCW**.

CHAPTER 7 - FAULT FINDING

1 - LOUD CRACKLING NOISE IN THE MOTOR AT STANDSTILL

Check that the Motor-Amplifier-Controller ground connections actually answer the requirements of Chapter 4.

Check that the wiring of the accumulator height sensor (**CV** input) and of the spool diameter sensor (**DIAM** input) actually answers the requirements of Chapter 4.

2 - LOUD NOISE IN THE MOTOR AT STANDSTILL AND WHEN RUNNING

Check the rigidity of the mechanical coupling between motor and load (backlashes and elasticities in the gearboxes and couplings).

Execute the **AUTO-TUNING** procedure again by selecting a lower bandwidth (**Medium** or **Low**).

If the problem remains, renew the **AUTO-TUNING** function by activating the antiresonance filter (**Filter = Antiresonance**). The antiresonance filter is accessible in the **BPCW** software version 2.6 and higher and the amplifier EPROM version **5.7** and higher.

3 - LOUD NOISE IN THE MOTOR WHEN RUNNING

Reduce the value of the **Analog input low pass filter** parameter of the menu **Advanced functions** of **BPCW** in order to filter, if necessary, the accumulator height measurement.

Renew the **AUTO-TUNING** procedure again by selecting a lower bandwidth (**Medium** or **Low**).

If the problem remains, renew the **AUTO-TUNING** function by activating the antiresonance filter (**Filter = Antiresonance**). The antiresonance filter is accessible in the **BPCW** software version 2.6 and higher and the amplifier EPROM version **5.7** and higher.