

SMT-BD1/p
Installation manual

gb

PROFIBUS
POSITIONER

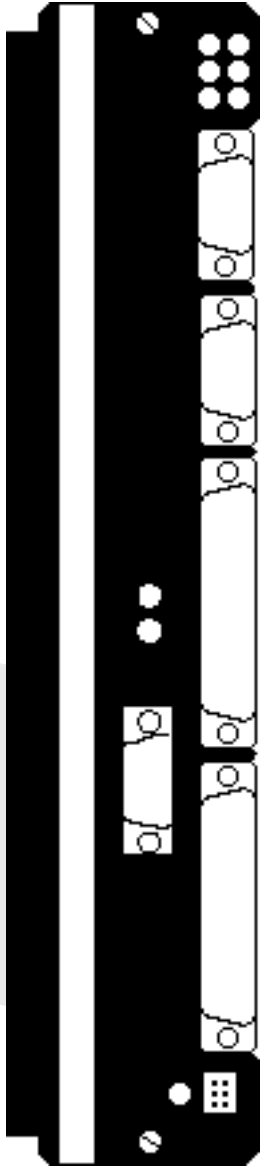

WARNING

This is a general manual describing a series of servo amplifiers having output capability suitable for driving AC brushless sinusoidal servo motors. This manual may be used in conjunction with appropriate and referenced drawings pertaining to the various specific models.

Maintenance procedures should be attempted only by highly skilled technicians (EN 60204.1 standard) using proper test equipment.

The conformity with the standards and the "CE" approval are only valid if the items are installed according to the recommendations of the racks and amplifiers manuals. The user assumes any responsibility for damages due to the non-answering of the connections recommendations and diagrams.

Any contact with electrical parts, even after power down, may involve physical damage. Wait for 5 minutes after power down before handling the amplifiers (a residual voltage of several hundreds of Volts may remain during several minutes).

INFRANOR drives are best protected against electrostatic discharges. However, some components are particularly sensitive and may be damaged. So, before handling the drives and, particularly, before any contact with the connectors, the user himself must be earthed by means of an antistatic and dissipating bracelet. Place or store the drives on a dissipating and earthed support or electrostatically neutral areas but not on plastic areas, carpeting or insulation material that may be electrostatically loaded.

INFRANOR does not assume any responsibility for any physical or material damage due to improper handling or wrong descriptions of the ordered items.

Infranor reserves the right to change any information contained in this manual without notice.

This manual is a translation of the original document and does not commit INFRANOR's responsibility. The french manual is the only reference document.

© INFRANOR, **Februar 2005**. All rights reserved.

Issue: **3.0**

Contents

PAGE

CONTENTS	4
CHAPTER 1 – GENERAL DESCRIPTION	7
1- INTRODUCTION	7
2- GENERAL DESCRIPTION	7
3 - REFERENCE TO THE STANDARDS	7
4 - REFERENCE TO OTHER DOCUMENTS	7
CHAPTER 2 – SPECIFICATIONS	8
1 - TECHNICAL SPECIFICATIONS.....	8
1.1 - <i>Current ratings for the 220 VAC amplifier version</i>	8
1.2 - <i>Current ratings for the 400 VAC amplifier version</i>	9
1.3 - <i>Other specifications</i>	10
2 – FUSE PROTECTION.....	11
2. 1 - <i>Fuse protection for the 220 VAC SMT-BD1/p amplifier version</i>	11
2. 2 - <i>Fuse protection for the 400 VAC SMT-BD1/p amplifier version</i>	11
CHAPTER 3 - INPUTS - OUTPUTS	12
1 – CONNECTORS LOCATION.....	12
1.1 - <i>RACK connectors</i>	12
1.2 - <i>Amplifier connectors</i>	12
2 – LEDs	12
2.1 – <i>Amplifier fault LEDs</i>	12
2.2 – <i>Profibus communication LEDs</i>	13
3 - X1: RESOLVER CONNECTOR	13
4 - X2: ENCODER CONNECTOR.....	13
5 - X4: CONTROL CONNECTOR	14
6 - X6: PROFIBUS	14
7 - X5: RS-232 CONNECTOR	14
8 - X3: TEST CONNECTOR.....	15
9 – LOGIC INPUTS-OUTPUTS SPECIFICATIONS	15
CHAPTER 4 - CONNECTIONS	16
1 - CONNECTION DIAGRAMS	16
1.1 – <i>Power supply and motor connections</i>	16
1.2 – <i>Serial link RS232 connection</i>	16
2 - WIRING RECOMMENDATIONS	16
2.1 – <i>Gnd wiring and grounding</i>	16
2.2 – <i>Connectors shield connection</i>	17
2.3 - <i>Motor and resolver cables</i>	18
2.4 - <i>Serial link cables</i>	18
3 – FIRST AMPLIFIER COMMISSIONING	18

CHAPTER 5 - APPENDIX	19
1 - HARDWARE ADJUSTMENTS	19
2 – ADJUSTMENT TO THE MOTOR	22
2.1 - Motor thermal sensor configuration	22
2.2 - Current loops adjustments	22
3 - ADJUSTMENT TO THE CONTROL LOGIC	24
3.1 - Positive or negative logic input	24
3.2 - Use of the "AMP. READY" and "POWER READY" outputs	24
4 – AMPLIFIER TYPES	25

Chapter 1 – General description

1- INTRODUCTION

Series SMT-BD1/p servo modules are PWM servo amplifiers that provide current, speed and position control for AC sinusoidal motors (brushless) with transmitter resolver.

The SMT-BD1/p servo drive is 220 VAC or 400 VAC mains operated. The SMT-BD1 plug-in system with 220 VAC power supply is available as a single-axis block version or as a multi-axis version that can receive up to six axes in a standard 19" rack including the power supply. The SMT-BD1 plug-in system with 400 VAC power supply is available as a multi-axis version that can receive up to three axes in a standard 19" rack including the power supply.

2- GENERAL DESCRIPTION

Series SMT-BD1 amplifiers have their own DC/DC converter to provide the appropriate supply voltage (+5 V, +/-15V). The source supply voltage for the control board is the auxiliary 310 VDC supply voltage. The auxiliary supply voltage allows to have the position signal still available when the power supply voltage is turned off.

Each module is packaged as a 6 U "double Eurocard":

- one power board with IGBT transistors
- one control board with DSP (Digital Signal Processing).

The SMT-BD1/p positioner operates with a PROFIBUS DP interface. The amplifier generates itself the positioning path; 128 positioning sequences can then be programmed this way.

3 - REFERENCE TO THE STANDARDS

The 220 VAC version of the SMT-BD1/p amplifiers operating in the BF rack, which is equipped with the mains filter BF-35 or 70, has been approved for its conformity with the Electromagnetic Compatibility standards:

- EN 55011, Group 1, Class A regarding the conducted and radiated radioelectric disturbances,
- CEI 801 - 2 - 3 - 4 regarding immunity.

The 220 VAC version of the SMT-BD1/p amplifiers operating in the single-axis racks BM 20 A – BMM 05F – BMM 05A, which are equipped with the appropriate mains filter (FN 612-20/06 or FN 356-16/06 or BF-35), has been approved for its conformity with the Electromagnetic Compatibility standards:

- EN 55011, Group 1, Class A regarding the conducted and radiated radioelectric disturbances,
- CEI 801 - 2 - 3 - 4 regarding immunity.

The 400 VAC version of the SMT-BD1/p amplifiers operating in the BF-400 rack, which is equipped with the mains filter F400-35 or 70, has been approved for its conformity with the Electromagnetic Compatibility standards:

- EN 55011, Group 1, Class A regarding the conducted and radiated radioelectric disturbances,
- CEI 801 - 2 - 3 - 4 regarding immunity.

Standard to be applied to the electrical equipments of industrial machines: EN 60204.1.

The SMT-BD1 amplifiers have been "CE" marked since 1995.

4 - REFERENCE TO OTHER DOCUMENTS

- ◆ [BF-400 rack](#) – for the use of the 400 VAC amplifier version in a multi-axis rack.
- ◆ [BF rack](#) – for the use of the 220VAC amplifier version in a multi-axis rack.
- ◆ [BM20A/BMM05F/05AF single-axis rack](#) – for the use of the 220 VAC amplifier version in a single-axis rack.
- ◆ [SMT-BD1/p CD1/p PROFIBUS](#) positioner user manual.

Chapter 2 – Specifications

1 - TECHNICAL SPECIFICATIONS

1.1 - Current ratings for the 220 VAC amplifier version

Operating voltage	DC bus 310 VDC (270 VDC < DC bus < 340 VDC max.)
Auxiliary supply voltage	310 VDC (200 VDC < Uaux < 340 VDC max.)
Motor terminal to terminal output voltage	200 Vrms for 310 VDC bus

Authorized output currents for operation in **current pulse mode** (I^2t protection in fusing mode)

AMPLIFIER	U rated (Vrms)	Imax (A rms) 1 s	Max. authorized rated current (Arms) of the amplifier		
			WITHOUT FAN*	FAN TYPE 1*	FAN TYPE 2*
SMT-BD1/p - 220/04	240	4,4	2		
SMT-BD1/p - 220/08	240	8,8	4		
SMT-BD1/p - 220/12	240	13,8	6		
SMT-BD1/p - 220/17	240	17,7	8,5		
SMT-BD1/p - 220/30	240	30,8	10	12	15
SMT-BD1/p - 220/30r	240	30,8	10	15	
SMT-BD1/p - 220/45	240	48,6	10	15	20
SMT-BD1/p - 220/45r	240	48,6	10	20	23
SMT-BD1/p - 220/60	240	61	10	19	25
SMT-BD1/p - 220/60r	240	61	12	26	30
SMT-BD1/p - 220/70	240	70	25	30	35
SMT-BD1/p - 220/100	240	100	25	30	35

Authorized output currents for operation in **continuous current mode** (I^2t protection in limiting mode)

AMPLIFIER TYPE	U rated (Vrms)	Imax (A rms) 1 s	Max. authorized continuous current (Arms) of the amplifier		
			WITHOUT FAN*	FAN TYPE 1*	FAN TYPE 2*
SMT-BD1/p - 220/04	240	4,4	2		
SMT-BD1/p - 220/08	240	8,8	4		
SMT-BD1/p - 220/12	240	13,8	6		
SMT-BD1/p - 220/17	240	17,7	8,5	8,5	
SMT-BD1/p - 220/30	240	30,8	8,5	12	15
SMT-BD1/p - 220/30r	240	30,8	10	15	
SMT-BD1/p - 220/45	240	48,6	8,5	15	18
SMT-BD1/p - 220/45r	240	48,6	10	20	23
SMT-BD1/p - 220/60	240	61	8,5	17	20
SMT-BD1/p - 220/60r	240	61	12	26	30
SMT-BD1/p - 220/70	240	70	17	30	35
SMT-BD1/p - 220/100	240	100	25	30	35

* Maximum ambient temperature = + 40° C, fan 1 = 56 l/s, fan 2 = 90 l/s.

Note: The **SMT-BD1/p-X/Xr** amplifier types are equipped with an additional heatsink in order to improve the heat dissipation and increase their rated current. The width of these amplifier types is then 18 TE instead of 12 TE.

Minimum inductance between phases 1 mH

Conformity with the standards: **CE** approval with multi-axis power supply configuration BF rack with mains filter BF-35 or 70, or SMTB.M 20 A / BMM05F/AF single-axis rack with filters FN 612-20/06 or FN 356-16/06 or BF-35. 360° shields; equipotentiality according to the wiring rules.

- EMC standards
 Immunity: CEI standards 801- 2 - 3 - 4
 Conducted and radiated disturbances: EN 55011, Group 1, class A
 - Electrical standards for industrial machines:
 EN 60204.1: - Insulator: 1500 VAC/1 min.
 - Leakage current > 3 mA
 (EMI filters)

Temperature range

* storage - 20°C to + 70°C
 * operation 5°C to +40°C
 From 40°C on, the rated currents must be reduced of 3 %/°C.
 Max. temperature: 50°C

1.2 - Current ratings for the 400 VAC amplifier version

Operating voltage

DC bus 565 VDC (480 VDC < DC bus < 685 VDC max.)

Auxiliary supply voltage

310 VDC (200 VDC < Uaux < 340 VDC max.)

Motor terminal to terminal output voltage

380Vrms for 565 VDC bus

Authorized output currents for operation in **current pulse mode** (I^2t protection in fusing mode)

AMPLIFIER	U rated (Vrms)	I _{max} (A rms) 1 s	Max. authorized rated current (Arms) of the amplifier	
			WITHOUT FAN*	FAN TYPE 2*
SMT-BD1/p - 400/15	400	15.5	5	7.5
SMT-BD1/p - 400/30	400	30	8	15
SMT-BD1/p - 400/45	400	48	10	19
SMT-BD1/p - 400/60	400	60	not used	28

Authorized output currents for operation in **continuous current mode** (I^2t protection in limiting mode)

AMPLIFIER TYPE	U rated (Vrms)	I _{max} (A rms) 1 s	Max. authorized continuous current (Arms) of the amplifier	
			WITHOUT FAN*	FAN TYPE 2*
SMT-BD1/p - 400/15	400	15.5	not used	5
SMT-BD1/p - 400/30	400	30	not used	10
SMT-BD1/p - 400/45	400	48	not used	15
SMT-BD1/p - 400/60	400	60	not used	23

* Maximum ambient temperature = + 40° C, fan 2 = 90 l/s.

Minimum inductance between phases

2 mH

Conformity with the standards: **CE** approval with multi-axis power supply configuration BF-400 rack and mains filter F400-35 or 70. 360° shields; equipotentiality according to the wiring rules.

- EMC standards
 Immunity: CEI standards 801- 2 - 3 - 4
 Conducted and radiated disturbances: EN 55011, Group 1, class A
 - Electrical standards for industrial machines:
 EN 60204.1: - Insulator: 2500 VAC/1 min.
 - Leakage current > 3 mA
 (EMI filters without capacitors)

Temperature range

* storage - 20°C to + 70°C
 * operation 5°C to +40°C
 From 40°C on, the rated currents must be reduced of 3 %/°C.
 Max. temperature: 50°C

1.3 - Other specifications

PWM switching frequency	10 KHz
Current regulator (PI)	Adjusted to the motor
Current loop bandwidth	Cut-off frequency for 45° phase shift > 1 kHz
Internal current limitation	Imax: 20 % to 100 % and Irated: 20 % to 50 % Imax duration = 1 second
Speed and position regulators	Sampling period = 0,5 ms Anti-wind-up system of the integrator Adjustable digital gains
Speed loop bandwidth	Selectable cut-off frequency for 45° phase shift: 50 Hz, 75 Hz or 100 Hz
Max. motor speed	Adjustable from 100 rpm to 10 000 rpm
Encoder position output	Two A and B channels in quadrature + n zero pulses per revolution. Programmable resolution: max. 8 192 ppr up to 900 rpm max. 4 096 ppr up to 3 600 rpm max. 1 024 ppr up to 10 000 rpm Accuracy: 8 arc minutes + 1/4 point (optional: 2 arc minutes + 1/4 point) <u>Note</u> : The total position accuracy must take into account the accuracy of the resolver used
Analog outputs (test connector)	Speed input command (CV): ±10 V for ± max speed Speed monitor (GT): ±8 V for ±14 000 rpm, linearity: 10% Current input command (IDC): ±10 V for ± current rating, resolution: 8 bits Current monitor (Imes): ±10 V for ± current rating, résolution: 8 bits
Logic inputs	Enable / Disable: ENABLE Limit switch +: FC+ Limit switch -: FC- Indexing input: INDEX Fault reset: RAZ
Relay outputs	Relay contact: Umax = 60 V Imax = 200 mA, Pmax = 10 W "Amp ready": closed if amplifier OK, open if fault "Power ready": closed if power OK, open if fault Brake control
PROFIBUS link	PPO-1 or PPO-2 or PPO-3 or PPO-4.
Fault display	LEDs on front panel and diagnostic by serial link RS232 + diagnostic by PROFIBUS.
Motor and application parameter setting	Serial link RS232 or Profibus DP link
Automatic functions	Amplifier adjustment to the motor (AUTO-PHASING) Automatic regulator tuning (AUTO-TUNING)
Altitude	1000 m
Moisture	< 50% to 40° C and < 90% to 20° C: EN 60204-1 standard
Cooling	Natural convection or forced air according to the rated current

2 – FUSE PROTECTION

2.1 - Fuse protection for the 220 VAC SMT-BD1/p amplifier version

F1 : Control of the average DC current of the power board supply.

F2 : Control of the average DC current of the logic board supply.

AMPLIFIER TYPE	F1 Power	F2 Logic
SMT-BD1/p-220/04 to 12	10 AT	1 A
SMT-BD1/p-220/17 and 30	15 AT	1 A
SMT-BD1/p-220/45	20 AT	1 A
SMT-BD1/p-220/60	20 AT	1 A
SMT-BD1/p-220/70	-	1 A
SMT-BD1/p-220/100	-	1 A

2.2 - Fuse protection for the 400 VAC SMT-BD1/p amplifier version

F2 : Control of the average DC current of the logic board supply.

AMPLIFIER TYPE	F2 Logic
SMT-BD1/p - 400/15	1 A
SMT-BD1/p - 400/30	1 A
SMT-BD1/p - 400/45	1 A
SMT-BD1/p - 400/60	1 A

Chapter 3 - Inputs - Outputs

1 – CONNECTORS LOCATION

1.1 - RACK connectors

For the 400 VAC amplifier version, see [BF-400 RACK manual](#).

For the 220 VAC amplifier version, see [SMTB.M 20 A SINGLE-AXIS RACK manual](#) or [BF RACK manual](#).

1.2 - Amplifier connectors

Front panel connectors

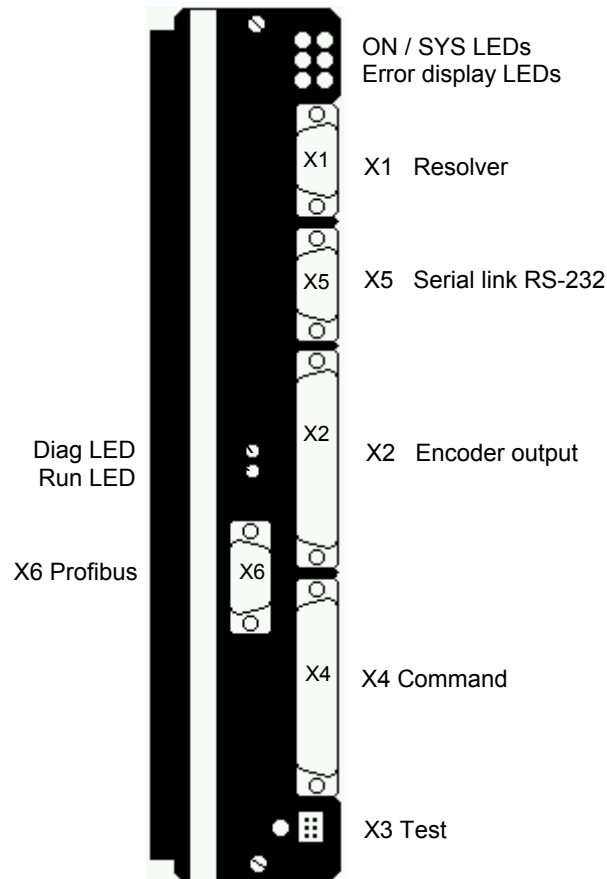

2 – LEDs

2.1 – Amplifier fault LEDs

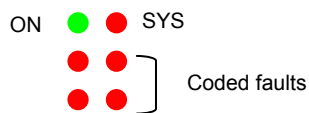

Location: above the resolver connector X1



ON (green): power supply
SYS: system fault

2.2 – Profibus communication LEDs

Location: above the Profibus connector X6

- DIAG  Diagnostic of the Profibus interface
 RUN  Communication OK

3 - X1: RESOLVER CONNECTOR

Sub D 9 pins female.

PIN	FUNCTION	NOTE
1	TC (motor thermal sensor)	pin H sensor connector for MAVILOR motor
6	Shield connection	If no « 360° » connection on the connector
2	TC (motor thermal sensor)	pin I sensor connector for MAVILOR motor
7	S1 (+sin resolver)	pin C sensor connector for MAVILOR motor
3	S3 (-sin resolver)	pin D sensor connector for MAVILOR motor
8	S4 (+cos resolver)	pin B sensor connector for MAVILOR motor
4	S2 (-cos resolver)	pin A sensor connector for MAVILOR motor
9	R2 (+ref resolver)	pin F sensor connector for MAVILOR motor
5	R1 (-ref resolver)	pin E sensor connector for MAVILOR motor

4 - X2: ENCODER CONNECTOR

Sub D 25 pins female.

PIN	SIGNAL	I/O	DESCRIPTION
1	/CZ	O	Differential output of the encoder marker pulse (5 V 20 mA max.)
2	CZ	O	Differential output of the encoder marker pulse
3	/CA	O	Differential output of the encoder channel /A (5 V 20 mA max.)
4	CA	O	Differential output of the encoder channel A
5	/CB	O	Differential output of the encoder channel /B (5 V 20 mA max.)
6	CB	O	Differential output of the encoder channel B
7, 10, 11	0 V		
25	GND		
8, 9, 12, 14 15, 16, 17, 18, 20, 21 22, 23, 24			Reserved

5 - X4: CONTROL CONNECTOR

Sub D 25 pins male.

Pin	Signal	I/O	Remark
1	Limit switch +	I	Positive logic or negative logic
14	Limit switch -	I	Positive logic or negative logic
24	0 V of limit switch	I	
20	ENABLE	I	Positive logic or negative logic
23	0 V ENABLE	I	
7	INDEX	I	Positive logic or negative logic
25	0 V logic input		
13	RAZ	I	Fault reset via 0 Volt (contact between pins 13 and 12)
12	0 V RAZ	I	
3, 15, 16, 17	Reserved		
10	Speed monitor output	O	GT: ± 8 V for $\pm 14\ 000$ rpm, linearity: 10%
2	Current monitor output	O	DACout2: ± 10 V for \pm current rating, resolution = 8 bits
11	0 Volt analog output	O	
18,19	Amp ready	O	Relay contact: closed when amplifier OK Pmax = 10 W with Umax = 60 V or Imax = 200 mA
8, 9	Brake control output	O	Relay contact Pmax = 10 W with Umax = 60 V or Imax = 200 mA
21	+15 Volts	O	Max. 50 mA
22	-15 Volts	O	Max. 50 mA
5, 6	non connected		

6 - X6: PROFIBUS

Sub D 9 pins female.

PIN	SIGNAL	DESCRIPTION
1	Shield	Shield
2		
3	RxD/TxD-P	Data reception/transmission (Plus)
4	CNTR-P	Control signal
5	DGND	0 V
6	VP	Supply for termination resistor
7		
8	RxD/TxD-N	Data reception/transmission (Minus)
9		

7 - X5: RS-232 CONNECTOR

Sub D 9 pins male.

PIN	FUNCTION	NOTE
5	0 Volt	GND (shield connection if no "360°" connection on the connector)
3	TXD	Transmit data RS-232
2	RXD	Receive data RS-232
6	TXH	Transmit data RS-422
7	TXL	Transmit data RS-422
8	RXL	Receive data RS-422
9	RXH	Receive data RS-422

8 - X3: TEST CONNECTOR

PIN	FUNCTION	NOTE
1 - 6	0 Volt	
2	Current input command IDC	± 10 V; resolution: 8 bits, linearity: 10 % (DAC out 1)*
4	Speed monitor GT	± 8 V for ± 14000 rpm
5	Current monitor Imes	± 10 V; resolution: 8 bits, linearity: 10 % (DAC out 2)*
3	Reserved	

* : 10 V for amplifier current rating.

9 – LOGIC INPUTS-OUTPUTS SPECIFICATIONS

1 – Dedicated logic inputs: FC+, FC-, INDEX and ENABLE

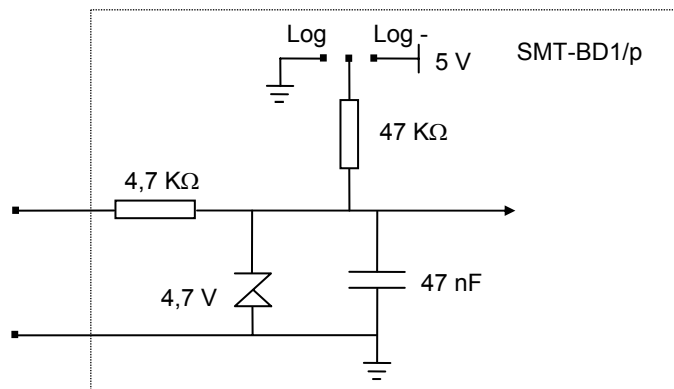

Input impedance: 4,7 KΩ.
Response time: 500 μs.

These inputs can be configured in positive or negative logic by means of jumpers (see chapter 5, section 3.1).

Chapter 4 - Connections

1 - CONNECTION DIAGRAMS

1.1 – Power supply and motor connections

For the 400 VAC amplifier version, see BF-400 RACK manual.

For the 220 VAC amplifier version, see SMTB.M 20 A SINGLE-AXIS RACK manual or BF RACK manual.

1.2 – Serial link RS232 connection

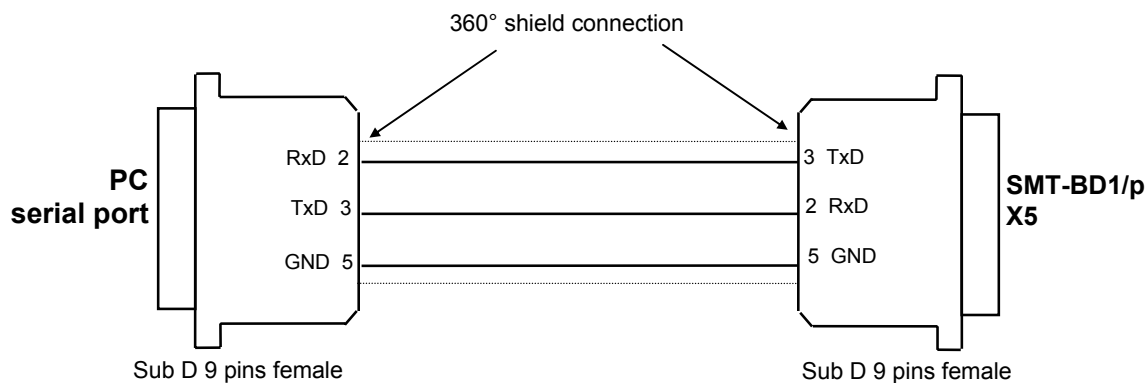

2 - WIRING RECOMMENDATIONS

(according to standards CEI 801 and EN55011 - see diagram "Shield connection on the connectors" - chapter 4, section 2.2).

2.1 – Gnd wiring and grounding

CAUTION

Each potential conducting element must be shielded. Several potential conductors in the same sleeve must be **twisted and shielded**.

A shield has no effect if it is not connected:

- to a reference potential,
- by a connection as short as possible (a few centimeters; 10 centimeters is prohibited),
- by a "360°" shield connection. This means that that whole circumference of the shield sleeve must be connected to the reference conduction via a metal collar.

The connectors used for the compliance with the CEI 801 standard must be metal or metallized connectors and must allow the 360° shield connections.

Reference potential connections (especially with the ground) are recommended **only** these connections have a very low impedance ($< 0,1 \Omega$). Any shield that is used as a conductor can be connected at both ends with the condition to be connected over 360° at both ends by means of metal links in order to ensure the shield continuity.

The preferred reference potential is the **earth**.

Cables with low potential should **never** run in the proximity of power lines.

If there is a potential reference, i.e. a main chassis or cabinet with a low impedance between its different elements, it should be used to connect ALL reference to it and also being grounded itself.

2.2 – Connectors shield connection

RULE

The shield should never be interrupted or corrupted over the whole cable length.

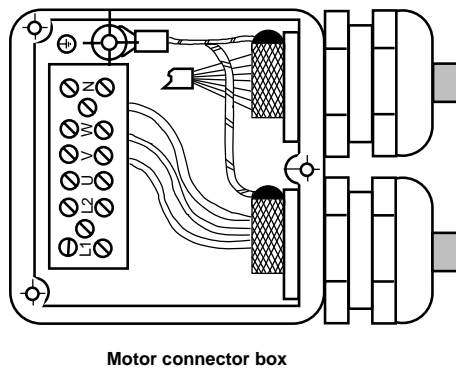
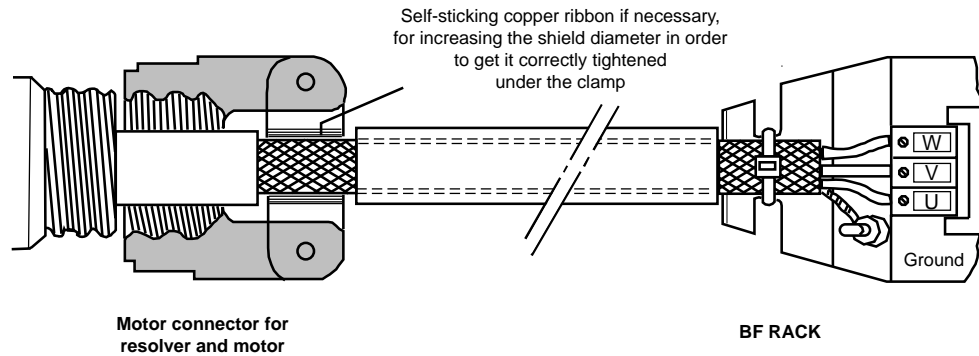

The cable can be soldered on the shield because the connector box is metallic. This solution does not exactly meet the EMC requirements but it is acceptable.

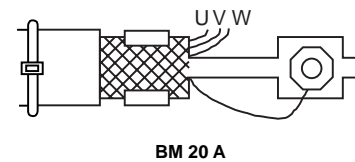
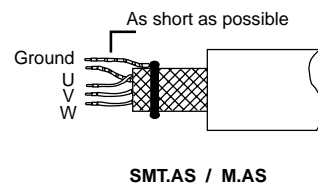
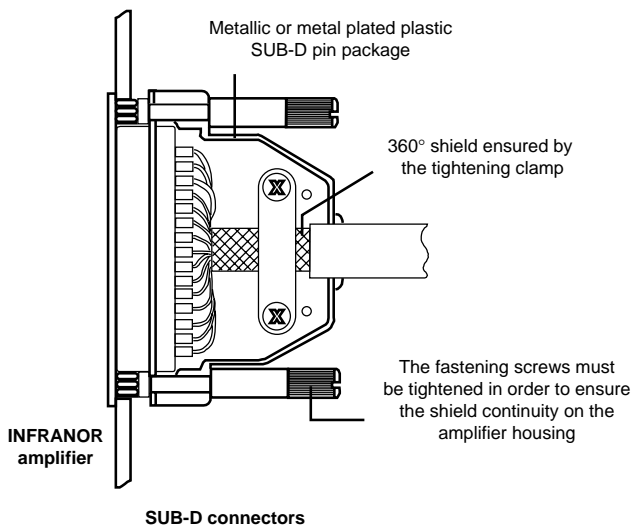

NOTE

When the 360° shield connection is made by means of a collar, it is not necessary to connect a cable on the appropriate pin of the SUB-D connector.

2.3 - Motor and resolver cables

Motors and resolvers are grounded via their housing.

Cable inputs should be made by means of metal connectors with collars allowing the 360° shield connection.

The resolver cable must be pair twisted and shielded (sin, cos, ref.). Motor cables MUST also be shielded.

2.4 - Serial link cables

The serial link cable must also be shielded according to the above mentioned shield connection recommendations.

CAUTION

Command cables (resolver, serial link, Profibus) as well as the power must be connected and disconnected with amplifier **OFF**.

3 – FIRST AMPLIFIER COMMISSIONING

The auxiliary supply voltage must be switched on before the power supply voltage.

Test the auxiliary supply voltage :

Rated value = 230 Vrms single-phase.

Maximum value (must never be exceeded) = 260 Vrms, all mains variation tolerances included.

Switch on the auxiliary supply. The green ON Led must be lit and the UNDERVOLT. error must be displayed.

Test the power supply voltage :

- For the 220 VAC amplifier version: **Rated value = 230 Vrms between phases.**

Maximum value (must never be exceeded) = 260 Vrms, all mains variation tolerances included.

- For the 400 VAC amplifier version: **Rated value = 400 Vrms between phases.**

Maximum value (must never be exceeded) = 480 Vrms, all mains variation tolerances included.

Switch on the power supply. The UNDERVOLT error Leds must be unlit. The braking resistor must remain cool.

CAUTION

The braking resistor is under high voltage.

When turning off the amplifier, wait for at least 5 seconds before turning power on again.

Chapter 5 - Appendix

1 - HARDWARE ADJUSTMENTS

All the hardware adjustments of the SMT-BD1/p amplifier module are presented on the following diagrams.

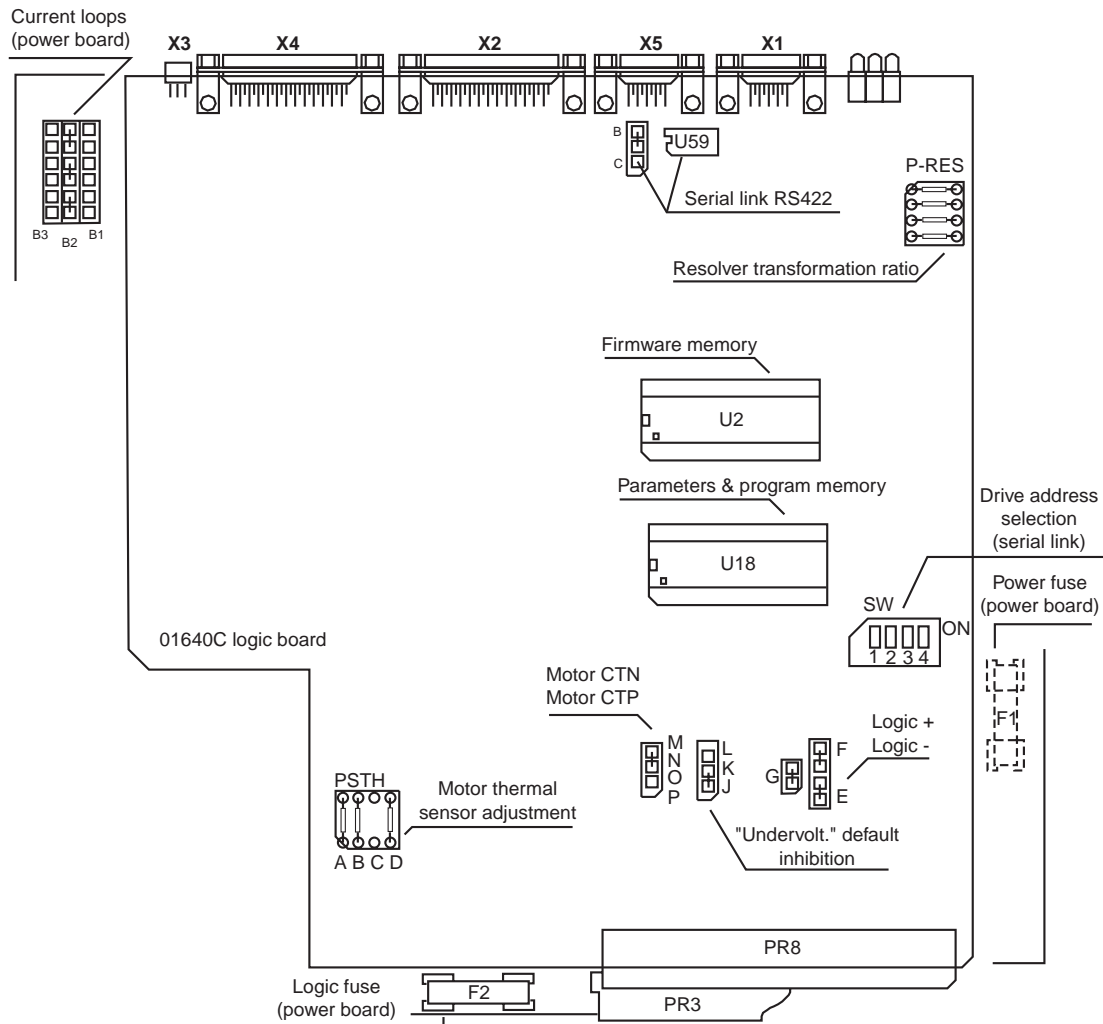

When using resolvers with transformation ratios other than 0.5, the Cos and Sin signal amplitude must be adjusted by means of the "P-RES" components according to the table below:

Resolver transformation ratio adjustment	P-RES			
Transformation ratio value	0,3	0,45	0,5	1
A - B - C - D tolerance < 1 %	21 K	14,3 K	12,7 K	6,34 K

In standard, the serial link is the RS232 link, with jumper B closed. In option, the amplifier can be delivered with a RS422 serial link, with jumper C closed.

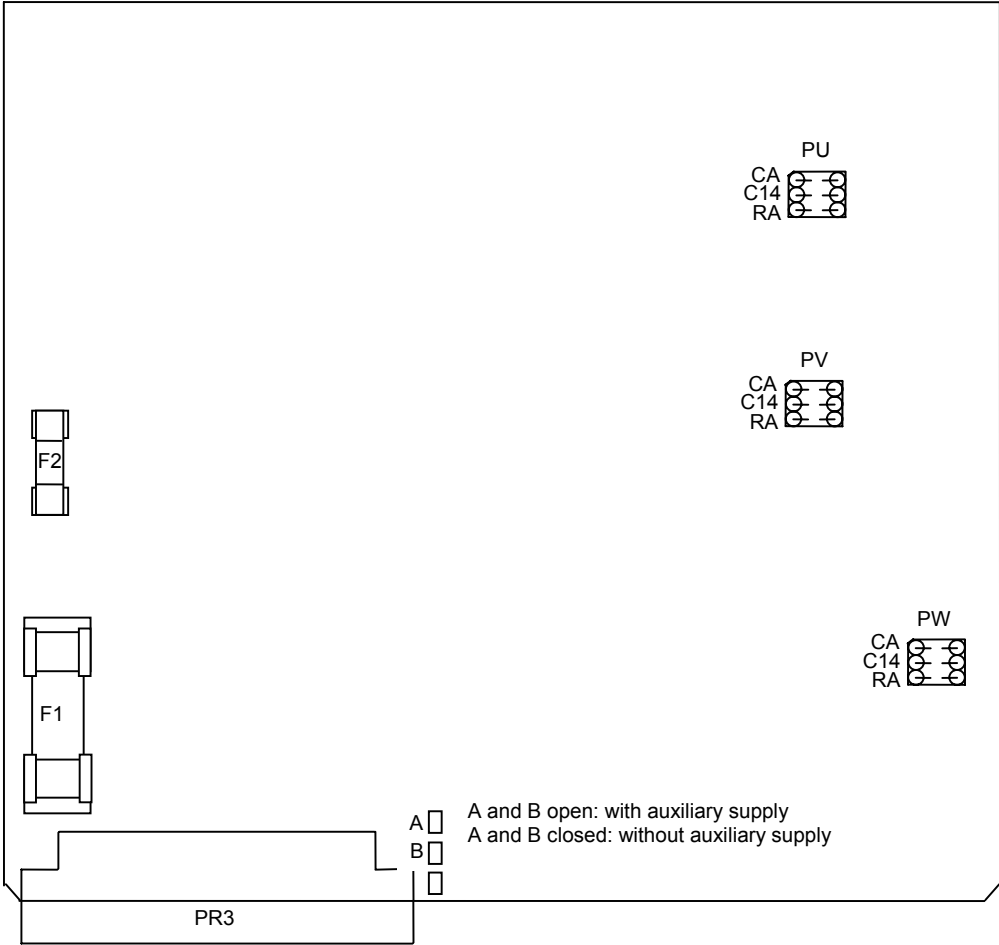

Power board adjustment for amplifier types 220/70 and 220/100

BRAKING SYSTEM SELECTION FOR SMT-BD1/p-220/04w to 220/60w

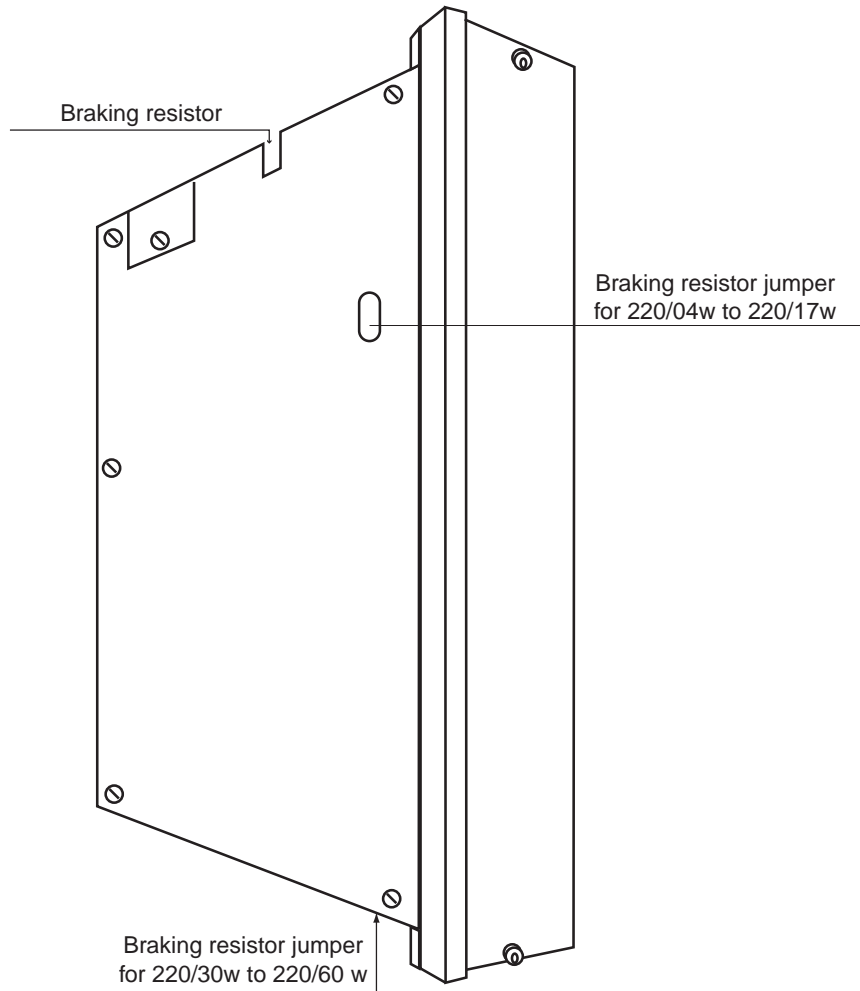

SMT-BM20 A/BMM05F/05AF single-axis rack: Braking resistor jumper closed.
BF rack: Braking resistor jumper open.

NOTE

The braking resistor selection is only available on "w" referenced amplifiers

2 – ADJUSTMENT TO THE MOTOR

2.1 - Motor thermal sensor configuration

Select the right MN or OP jumper setting according to the motor thermal sensor type (PTC or NTC).

2.1.1 - PTC THERMAL SENSOR

On motors equipped with a PTC thermal sensor (triggering on high impedance), the amplifier configuration is the following: MN jumper closed and OP jumper open. The triggering threshold adjustment for the PTC thermal sensor is made by means of the PSTH components: PSTH-D = 14,3 kΩ; PSTH-B = 28 kΩ; PSTH-A = 3 x RPTC (120°C) in kΩ. RPTC (120°C) = ohmic value of the PTC thermal sensor resistor at 120°C. The default adjustment is RPTC (120°C) # 3 kΩ with PSTH-A = 10 kΩ.

2.1.2 - NTC THERMAL SENSOR

On motors equipped with an NTC thermal sensor (triggering on low impedance), the amplifier configuration is the following: OP jumper closed and MN jumper open. The triggering threshold adjustment for the NTC thermal sensor is made by means of the PSTH components: PSTH-D = 14,3 kΩ; PSTH-B = 28 kΩ; PSTH-A = 3 x RNTC (120°C) in kΩ. RNTC (120°C) = ohmic value of the NTC thermal sensor resistor at 120°C. The default adjustment is RNTC (120°C) # 3 kΩ with PSTH-A = 10 kΩ.

2.2 - Current loops adjustments

2.2.1 - CURRENT LOOPS ADJUSTMENTS FOR THE 400 VAC AMPLIFIER VERSION

Select the right current loops jumpers setting (position B1, B2 or B3) according to motor and amplifier specifications.

For the 400 VAC version of the MAVILOR BL motor series, the current loops adjustments are made according to following selection table:

	AMPLIFIER			
MOTOR	15 A	30 A	45 A	60A
BL 113	B2			
BL 114	B2			
BL 115	B2	B1		
BL 141	B1	B1		
BL 142	B2	B1		
BL 143	B1	B1	B1	
BL 144	B1	B1	B1	
BL 191			B3	B3
BL 192			B3	B3

For other motors, the adjustment of the current loops according to the **amplifier current rating** and to the **inductance between the motor terminals** is made as follows:

15 A and 30 A amplifier current ratings

Calculation of $G = 0.8 \times \text{Amplifier current rating (A)} \times \text{Inductance between phases (mH)}$,

If $G < 60$, current loop jumpers (x3) on **B3** position,

If $60 < G < 100$, current loop jumpers (x3) on **B2** position,

If $G > 100$, current loop jumpers (x3) on **B1** position.

45 A and 60 A amplifier current ratings

Calculation of $G = 0.8 \times \text{Amplifier current rating (A)} \times \text{Inductance between phases (mH)}$,

If $G < 100$, current loop jumpers (x3) on **B3** position,

If $100 < G < 250$, current loop jumpers (x3) on **B2** position,

If $G > 250$, current loop jumpers (x3) on **B1** position.

2.2.2 - CURRENT LOOPS ADJUSTMENTS FOR THE 220 VAC AMPLIFIER VERSION

Select the right current loops jumpers setting (B1, B2 or B3 position) according to motor and amplifier specifications.

For the MAVILOR BL and MA motor series, the current loops adjustments are made according to following selection table.

AMPLIFIER \ MOTOR	4 A	8 A	12 A	17 A	30 A	45 A	60 A	70 A	100 A
MA 3		B1							
MA 6		B1	B1						
MA 10		B2	B1	B1	B1				
MA 20		B2	B1	B1	B1	B1	B1	B1	
MA 30				B2	B2	B2	B1	B1	
MA 45					B2	B2	B1	B1	B1
MA 55						B2	B2	B2	B1
BL 55-3	B1								
BL 55-5	B1								
BL 71		B2							
BL 72		B2	B1	B1					
BL 73		B2	B1	B1					
BL 74		B2	B1	B1					
BL 111		B1	B1						
BL 112		B2	B2	B1	B2				
BL 113		B3	B3	B2	B2	B2			
BL 114				B3	B3	B2	B2		
BL 115				B3	B3	B2	B2	B2	
BL 141				B2	B2	B2	B1	B1	
BL 142				B3	B3	B2	B2	B1	
BL 143				B3	B2	B2	B1	B1	B1
BL 144				B2	B2	B2	B1	B1	B1

For other motors, the adjustment of the current loops according to the **amplifier current rating** and to the **inductance between the motor terminals** is made as follows:

4 A, 8 A, 12 A and 17 A amplifier current ratings

Calculation of $G = 1,4 \times \text{Amplifier current rating (A)} \times \text{Inductance between phases (mH)}$,

If $G < 60$, current loop jumpers (x3) on **B3** position,

If $60 < G < 100$, current loop jumpers (x3) on **B2** position,

If $G > 100$, current loop jumpers (x3) on **B1** position.

30 A, 45 A, 60 A, 70 A and 100 A amplifier current ratings

Calculation of $G = 1,4 \times \text{Amplifier current rating (A)} \times \text{Inductance between phases (mH)}$,

If $G < 100$, current loop jumpers (x3) on **B3** position,

If $100 < G < 250$, current loop jumpers (x3) on **B2** position,

If $G > 250$, current loop jumpers (x3) on **B1** position.

3 - ADJUSTMENT TO THE CONTROL LOGIC

3.1 - Positive or negative logic input

The logic inputs **FC+**, **FC-**, **ENABLE**, **INDEX** of the logic X4 connector can be configured in **positive logic** (control by +24 V) or in **negative logic** (control by 0 V) as described below:

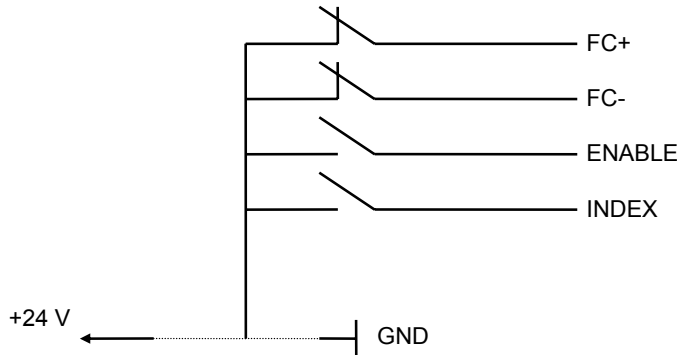

POSITIVE LOGIC: E-F-G jumpers closed.

Range: active at level: $5 < V < 30$ V
 Input impedance: 4,7 K Ω
 Response time: 500 μ s

NEGATIVE LOGIC: E-F-G jumpers open

Range: inactive or open at level $5 < V < 30$ V
 Input impedance: 4,7 k Ω
 Response time: 500 μ s

NOTE

The inputs **FC+**, **FC-**, **ENABLE**, **INDEX** of the X4 connector must all be in positive logic or all in negative logic.

3.2 - Use of the "AMP. READY" and "POWER READY" outputs

When an amplifier fault is released, the **AMP. READY** output is immediately disabled (contact is open). After elimination of the error source, the amplifier can be reset via pins 12 and 13 of the X4 connector.

If the amplifier control board must be kept active when a stored fault is released on the amplifier and the power supply turned off, it is necessary to have an auxiliary supply for the logic board which is independent from the power supply. In this case, the **JK** and **KL** jumpers of the logic board allow to inhibit or to release the "Undervolt." fault when the amplifier is turned on.

JK jumper closed and **KL** jumper open configuration :

If the auxiliary supply is turned on before the main power supply, the "Undervolt." fault is displayed and can hide a fault of lower priority. The **AMP READY** and **POWER READY** outputs are both inactive (contact is open) until the power supply is on.

JK jumper open and **KL** jumper closed configuration :

The "Undervolt." fault is inhibited when turning on the auxiliary supply before switching on the main power supply. The **AMP READY** output is then active and **POWER READY** remains inactive (contact open) until the main power supply is on.

NOTE

The **POWER READY** output is only available on the BF rack housing. Please see the BF RACK or the BF-400 RACK manual. If the **POWER READY** signal is not used, make the **JK** jumper on the amplifier in order to have the **AMP. READY** signal taking into account the power statement.

4 – AMPLIFIER TYPES

SMT-BD1 / _ p - _ / _ _ / _ - T - BS

Serial link :

1 = RS 232 2 = RS 422

Amplifier voltage ratings: 220 VAC or 400 VAC

Amplifier current ratings:

4 A to 100 A (220 VAC) or 15 A to 60 A (400 VAC)

r = Additional heatsink for 220 VAC amplifiers
(total width = 18 TE)

w = Braking system for 220 VAC amplifiers (single-axis rack)