

SINGLE-AXIS RACKS

gb

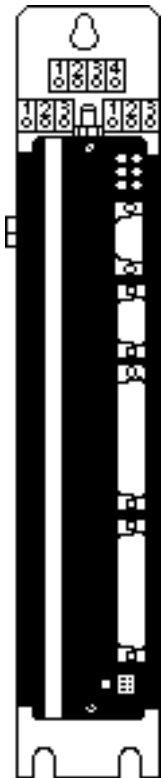

SMT-BM 20 A
BMM 05 F
BMM 05 AF

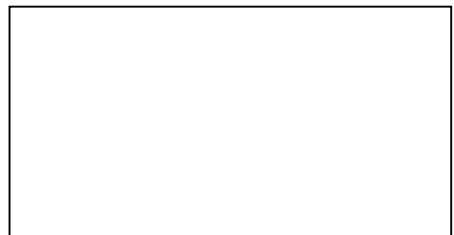

This is a general manual describing a series of racks receiving servo amplifiers having output capability suitable for driving AC brushless sinusoidal servo motors. This manual may be used in conjunction with appropriate and referenced drawings pertaining to the various specific models.

Maintenance procedures should be attempted by highly skilled technicians (EN 60204.1 standard) using proper test equipment.

The conformity with the standards and the "CE" certification are only valid if the items are installed according to the recommendations of the racks and amplifiers manuals.

Any contact with electrical parts, even after power down, may involve physical damage to equipment or people.

Wait for min. 30 seconds after power down before handling the rack or the amplifiers (residual voltage).

INFRANOR does not assume any responsibility for any physical or material damage due to improper handling or wrong descriptions of the ordered items.

INFRANOR reserves the right to change any information contained in this manual without notice.

This manual is a translation of the original document and does not commit INFRANOR's responsibility. The french manual is the only reference document.

Contents

CONTENTS	5
CHAPTER 1 – GENERAL DESCRIPTION	7
1 - CONFORMITY WITH EUROPEAN STANDARDS: "CE" APPROVAL.....	7
1.1 - Introduction	7
1.2 – Standards compliance	8
1.3 – Affixing of the « CE » label : 1995.....	8
CHAPTER 2 – SMT-BM 20 A	9
1 – SPECIFICATIONS	9
1.1 – Main technical datas	9
1.2 – Braking resistor	9
1.3 – Dimensions of the external protected resistor: « dp » housing.....	9
1.4 – Dimensions of the SMT-BM 20 A single-axis rack	10
1.5 – Current ratings depending on the various fan types of the SMT-BM 20 A single-axis rack.....	10
1.6 – SMT-BM 20 A rack types.....	11
2 – CONNECTION DIAGRAMS	12
2.1 – Diagram of the three-phase mains connection via a 400/230 autotransformer with auxiliary supply.....	12
2.2 – SMT-BM 20 A connections.....	13
2.3 – 230 Vac single-phase connection diagram.....	14
CHAPTER 3 – BMM 05 F – BMM 05 AF	15
1 – ELECTRICAL SPECIFICATIONS	15
2 – INPUTS-OUTPUTS	15
3 – DIMENSIONS	16
4 – RACK TYPES	17
5 – BMM 05 F.....	17
5.1 – Diagram of the connector to the 230 Vac single-phase mains	17
5.2 – Connections	18
6 – BMM 05 AF	18
6.1 – Diagram of the connection to the 230 Vac single-phase mains.....	18
6.2 – Connections	19
7 – CONFIGURATION.....	19
APPENDIX	20

Chapter 1 – General description

1 - CONFORMITY WITH EUROPEAN STANDARDS: "CE" APPROVAL

1.1 - Introduction

The SMT-BM 20 A, BMM 05 F and BMM 05 AF single-axis racks allow a large integration of the power supply, the auxiliary supply, the braking system and the mains filter while keeping the principle of the pluggable "B" series amplifiers.

Their use is especially recommended for decentralized axes; this often concerns axes connected via a field bus (CAN, PROFIBUS, etc.) as well as applications with a positioner ("m" version of the SMT-BD1 amplifier). The amplifier current ratings of both SMT-BD1 and SMTB.Si-2Tz series in 220 V used with the SMT-BM 20 A single-axis rack are between 4 A and 60 A peak. The 70 A and 100 A amplifiers can only run in a single-axis rack because of their dimensions. This also concerns the 400 V amplifier range.

The BMM 05 F or BMM 05 AF rack is only to be used with amplifiers equipped with the option "w" (braking system integrated in the amplifiers for their use in single-axis racks).

The BMM 05 F or BMM 05 AF rack is used with amplifier types with current rating ≤ 17 A. The capacity of the mains filter is limited at 5 Arms.

This manual must be used in conjunction with the standard manuals of the SMTB.Si-2Tz and SMT-BD1 amplifiers with 220 V input.

It describes the specifications and the commissioning:

- of the SMT-BM20 A standard version and its various accessories: mains filter, fan,
- of the low voltage BMM05 F or BMM 05 AF version including the mains filter, and which allows the control of a brake on the motor. This is useful for decentralized applications.

The SMT-BM 20 A single-axis rack is supplied:

- by the 230 VAC three-phase mains,
- via an isolated 400/230 VAC transformer,
- or via a 400/230 VAC autotransformer.

It is possible to have a 230 VAC single-phase mains supply (with a cheaper wiring than the three-phase supply), but it must be kept for low power applications. The three-phase supply should be preferred for average application currents that exceed 10 A (in order to limit voltage ripples).

An internal device in the SMT-BM 20 A limits the inrush current at power on.

The BMM 05 F or BMM 05 AF single-axis rack can only receive a single-phase supply:

- via the 220 VAC single-phase mains,
- via an isolated 380/220 VAC transformer,
- or via a 380/220 VAC auto-transformer.

An internal device, serially mounted with the power lines, allows to limit the inrush current at power on.

The SMT-BM 20 A standard version compliance with the CE recommendations requires a mains filter that must be mounted between the voltage source and the rack.

The recommended filters are:

- filter FN612-20/06 for a single-phase voltage,
- filter FN356-16/06 for a three-phase voltage.

Note: the BMM 05F or BMM 05 AF version includes this filter.

NOTE

The braking system protective function - in case of energy rejection by the motor on the DC power supply - is controlled by the amplifier and not by the single-axis rack. The protected resistor "w" is described in this manual with regard to its use in single-axis applications.

CAUTION

The connection diagrams must be carefully followed, especially when using the auxiliary supply, in order to keep the position information.

The earthing of the BM20 A housing is MANDATORY in order to ensure the users' physical safety in case of isolation failure to the mains. INFRANOR will withdraw its warranty on all items that do not meet this requirement.

1.2 – Standards compliance

The "B" series amplifiers mounted in the single-axis rack with mains filter BF35 have been approved for their conformity to the Electromagnetic Compatibility standards:

- EN55011, group 1, class A, regarding radioelectrical disturbances,
- CEI 801 - 2 - 3 - 4 regarding immunity.

The conditions and results of the tests made by the official LCIE laboratory (Laboratoire Central des Industries Electriques) approved by the European Community, are recorded under n° 416040, 416041, 416042 and 416043.

The test results according to the Low Voltage Directive are recorded in the LCIE report n° 413777.
Standard to be applied for electrical equipments of industrial machines: EN 60204-1.

1.3 – Affixing of the « CE » label : 1995

Chapter 2 – SMT-BM 20 A

1 – SPECIFICATIONS

1.1 – Main technical datas

Rated input power voltage	230 Vac three-phase +10% / -15%
Rated input auxiliary voltage	230 Vac single-phase +10% / -15%
Minimum auxiliary voltage	100 Vac single-phase
Continuous rated current on DC bus	28 Adc
Rated RMS current on the motor	20 Arms
Peak current on DC bus (5% of the time)	60 A

1.2 – Braking resistor

The braking resistor is depending on the current rating of the amplifier plugged in the single-axis rack.

AMPLIFIER TYPE	BRAKING RESISTOR VALUE	RATED POWER	PEAK POWER	BRAKING RESISTOR TYPE	BRAKING RESISTOR HOUSING TYPE
220/04 220/08 220/12 220/17	100 Ω	100 W	1,6 KW	RSSD 20 x 117	dp 100/100
220/30	2 x 100 Ω en parallel mounted	200 W	3,2 KW	RSSD 20 x 117	dp 50/200
220/45 220/60	15 Ω	280 W	10 KW	RSSD 30 x 250	dp 15/280

1.3 – Dimensions of the external protected resistor: « dp » housing

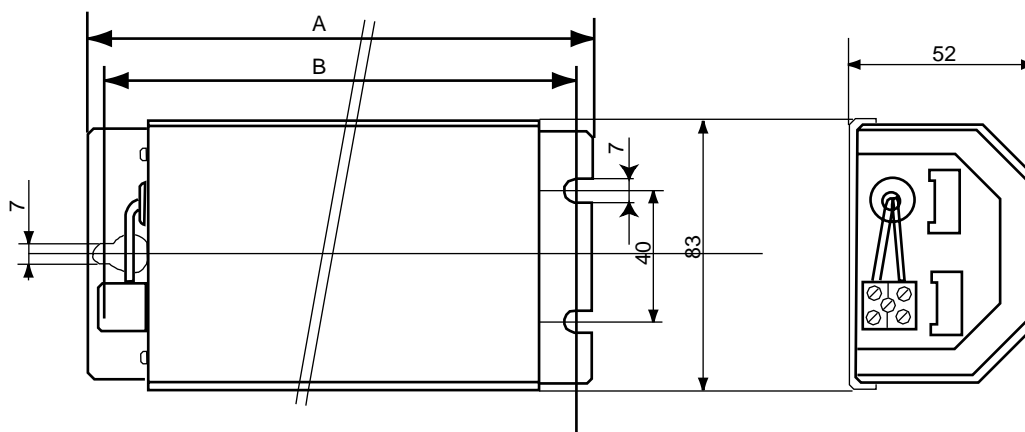

AMPLIFIER TYPE	220/04 to 220/30	220/45 and 220/60
Dimension A	157	290
Dimension B	145	278

1.4 – Dimensions of the SMT-BM 20 A single-axis rack

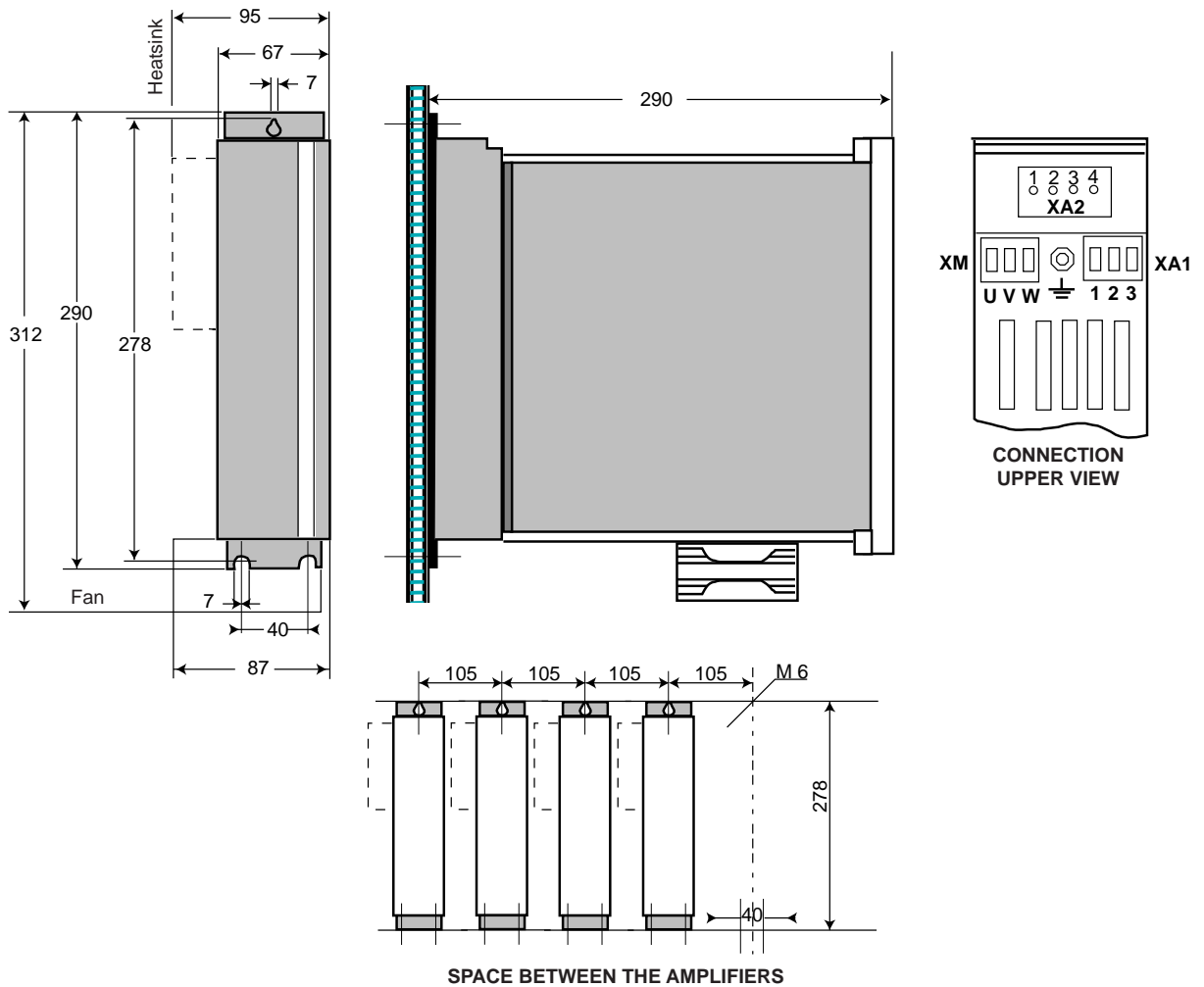

1.5 – Current ratings depending on the various fan types of the SMT-BM 20 A single-axis rack

TYPE	Urated (Vrms)	I _{max} (Arms) 1 s	I _{rated} (Arms)	
			Without fan	With fan
SMT-BD1 and SMTB.Si-220/04	230	4	2	
SMT-BD1 and SMTB.Si-220/08	230	8	4	
SMT-BD1 and SMTB.Si-220/12	230	13	6	
SMT-BD1 and SMTB.Si-220/17	230	17	8,5	
SMT-BD1 and SMTB.Si-220/30	230	29	10	12
SMT-BD1 and SMTB.Si-220/30r	230	29	10	15
SMT-BD1 and SMTB.Si-220/45	230	46	10	15
SMT-BD1 and SMTB.Si-220/45r	230	46	10	20
SMT-BD1 and SMTB.Si-220/60	230	58	10	19
SMT-BD1 and SMTB.Si-220/60r	230	58	12	20

NOTE: This table replaces the equivalent table mentioned in the amplifier manuals, that corresponds to the use in multi-axes racks.

1.6 – SMT-BM 20 A rack types

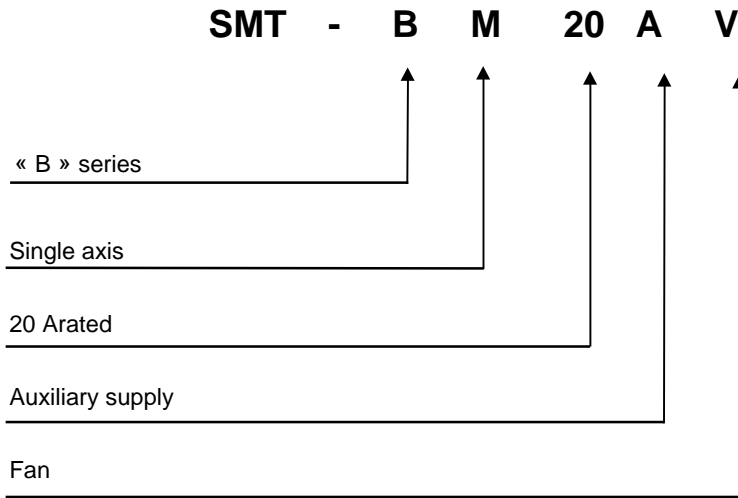

2 – CONNECTION DIAGRAMS

2.1 – Diagram of the three-phase mains connection via a 400/230 autotransformer with auxiliary supply

The auxiliary supply input can be wired between two 230 V phases at the autotransformer output. It can also be directly connected to the 230 V mains between phase and neutral.

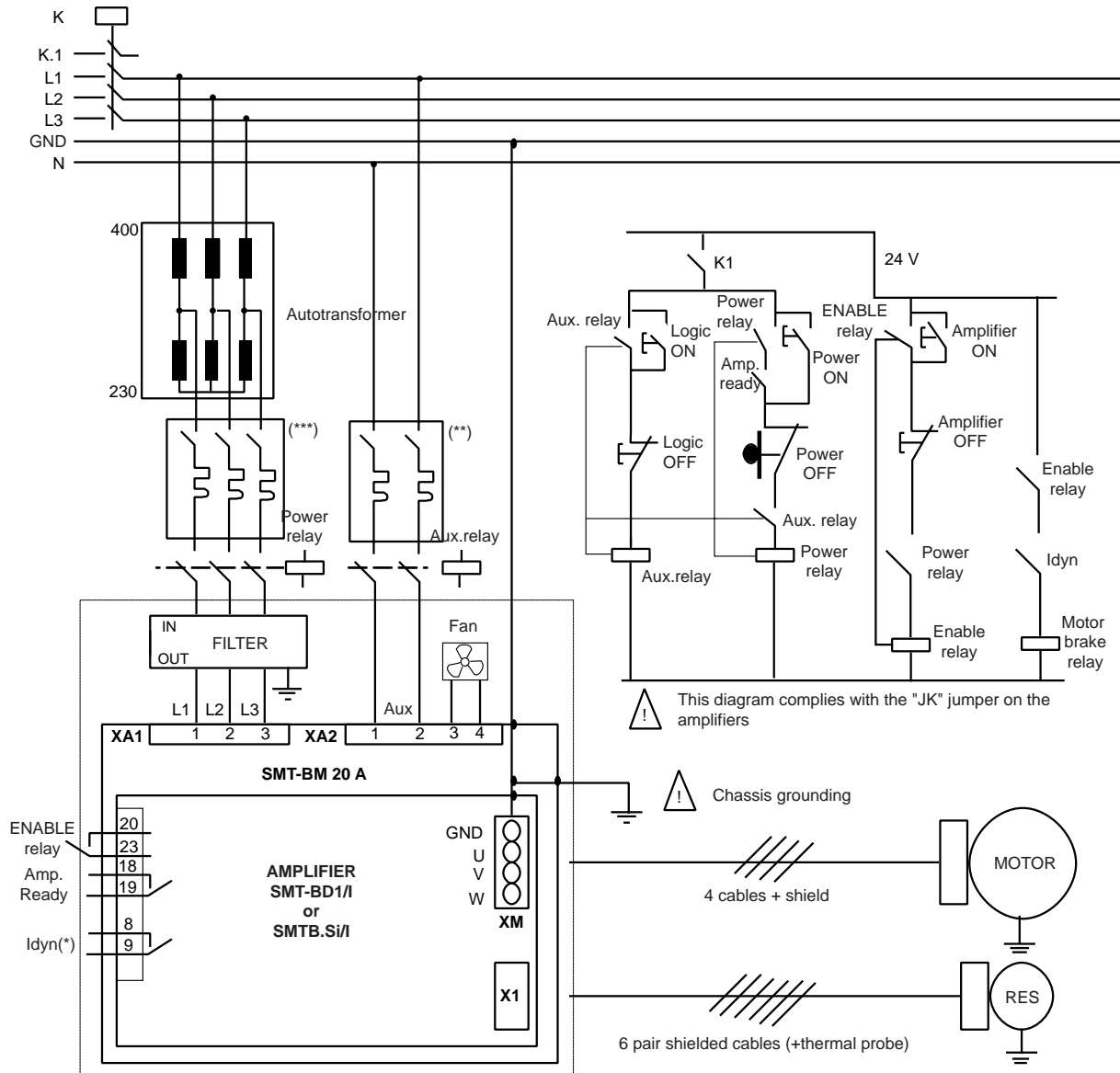

(*) Motor brake spool control on versions SMT-BD1/f, SMT-BD1/h and SMT-BD1/m
 (**) 3 A single-phase circuit breaker, curve C.
 (***) 12 A (20 A max.) circuit breaker, curve C.

IMPORTANT

The use of an autotransformer does not allow any isolation between the mains and power stage (and consequently motor). So, it is MANDATORY to mount a correctly sized circuit-breaker in case of a short-circuit inside the single-axis rack (rectifier bridge, power bridge, motor). The information AMP. READY (pins 18-19 of X4) must be used to open the Power Relay when a fault occurs.

2.2 – SMT-BM 20 A connections

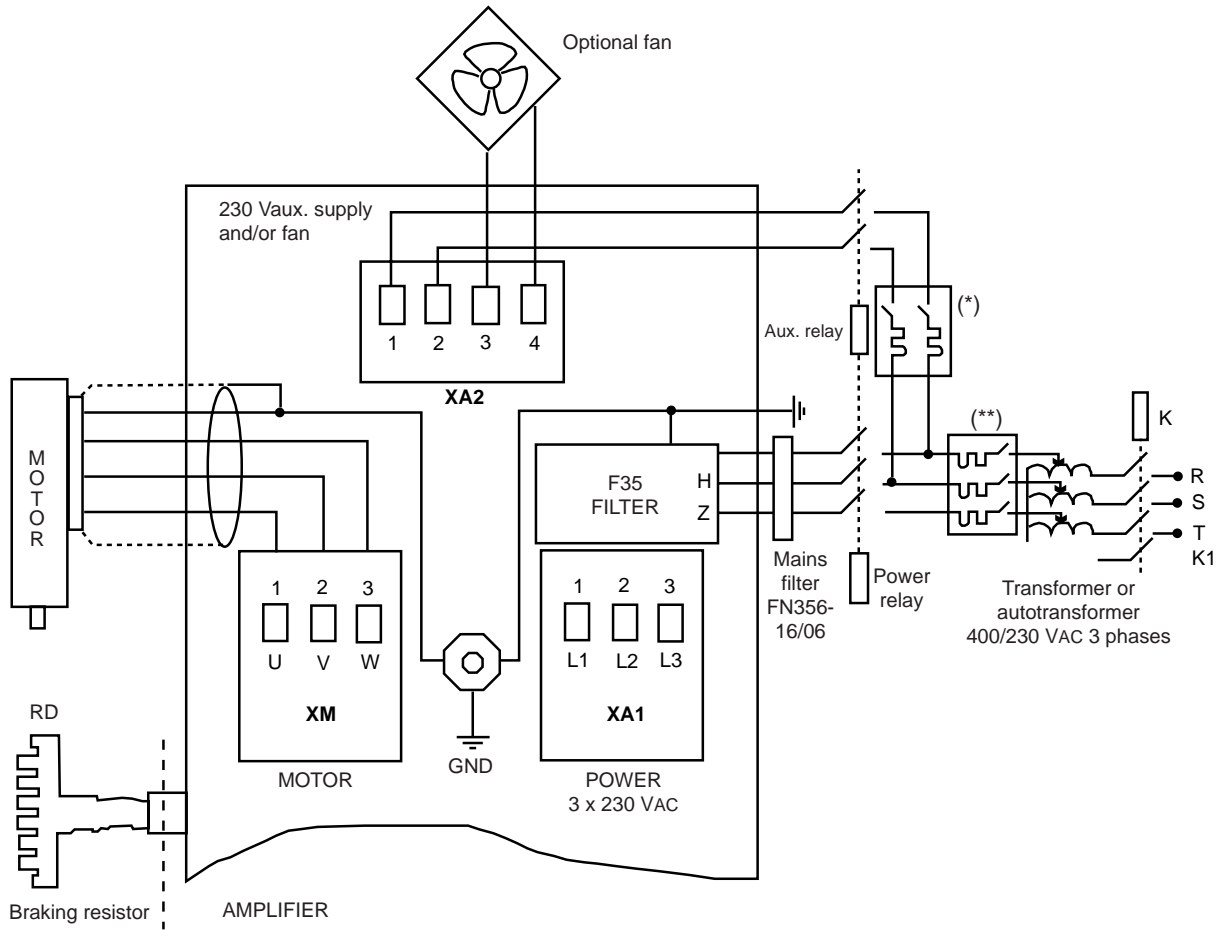

(*) 3 A single-phase circuit breaker, curve C
 (**) 12 A (20 A max.) circuit breaker, curve C

MOTOR SHIELD CONNECTION OVER 360°

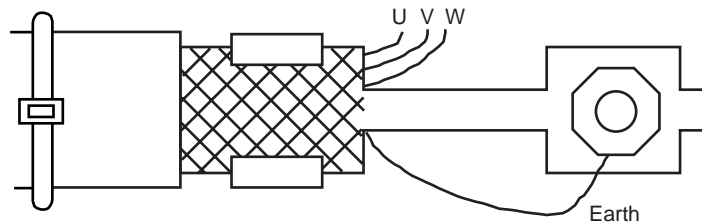

2.3 – 230 Vac single-phase connection diagram

This solution is only possible if the power and auxiliary supplies are single-phase connected to 230 VAC (phase/neutral).

But, the maximum RMS current must not exceed 10 Arms.

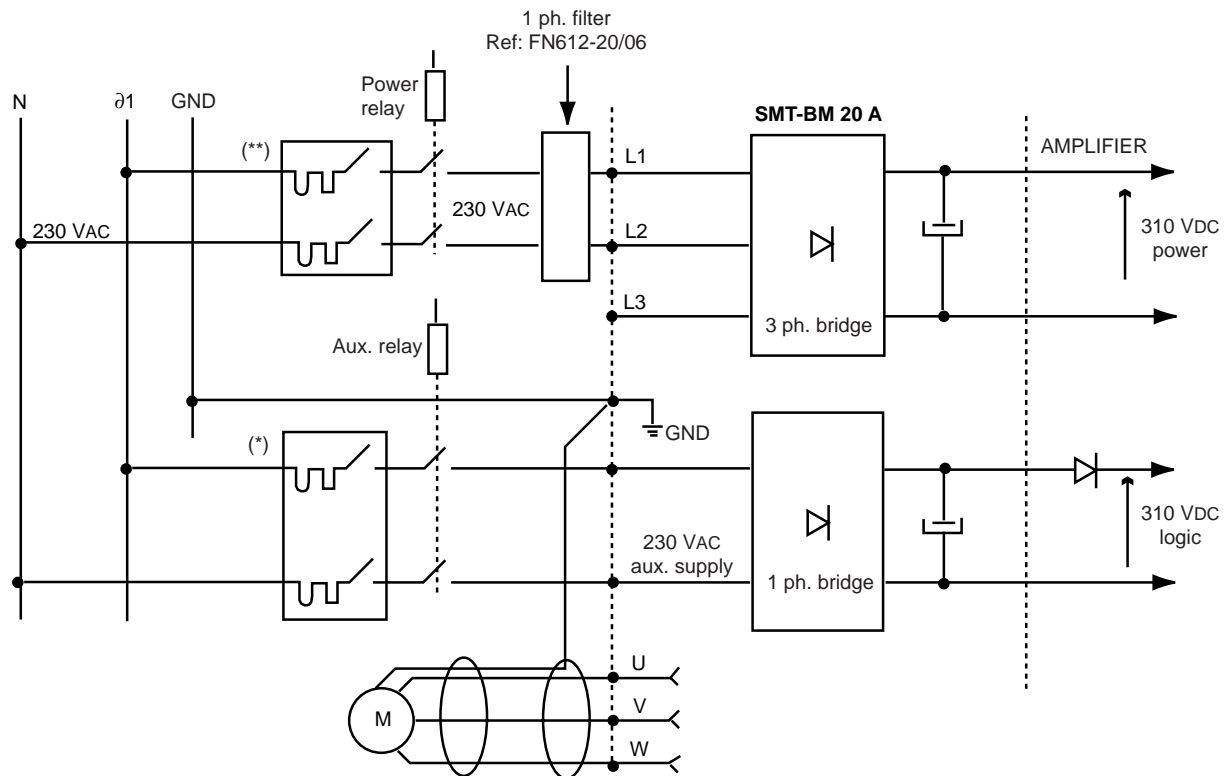

(*) Single-phase 3 A circuit-breaker, curve C
 (**) Single-phase 20 A circuit-breaker, curve C

Chapter 3 – BMM 05 F – BMM 05 AF

1 – ELECTRICAL SPECIFICATIONS

Rated auxiliary supply voltage	230 Vac single-phase +10% / -15%
Maximum auxiliary supply voltage	230 Vac +10%
Minimum auxiliary supply voltage	100 Vac
Rated power voltage	230 Vac single-phase +10% / -15%
Maximum power voltage	230 Vac +10%
Minimum power voltage	100 Vac
Continuous RMS rated current on the motor	05 Arms
RMS peak current on the motor	17 Arms
Rated input voltage of the brake supply	24 Vdc +/-10%
Maximum output current of the brake control relay	2 A
Maximum output power of the brake control relay	30 W
Minimum closing voltage	20 Vdc
Relay response time at the closing	4 ms
Relay response time at the opening	2 ms
Estimated number of opening/closing	10exp7
Main rejection filter (integrated in the module)	
Braking resistor (see chapter 2, section 1.2)	dp 100/100

2 – INPUTS-OUTPUTS

XA1 CONNECTOR

- XA1.1 : 0 V (24 V) supply
- XA1.2 : 24 Vdc supply and brake spool (+)
- XA1.3 : Brake spool (-)

XA2 CONNECTOR (BMM 05 AF ONLY)

- XA2.1 : 230 Vac single-phase auxiliary supply.
- XA2.2 : 230 Vac single-phase auxiliary supply.

XA3 CONNECTOR

- XA3.1 : 230 Vac single-phase power supply.
- XA3.2 : 230 Vac single-phase power supply.

XM CONNECTOR

- XM1 : Motor U phase.
- XM2 : Motor V phase.
- XM3 : Motor W phase.

GROUND SCREW: ground potential reference.

NOTE

The XA2 connector of the auxiliary supply is only available on the **BMM 05 AF version**.
 On the **BMM 05 F version**, the auxiliary supply is factory wired inside the rack from the power supply (XA3).

3 – DIMENSIONS

Same dimensions as the SMT-BM 20 A.
 The single-phase mains filter is mounted at the bottom of the module

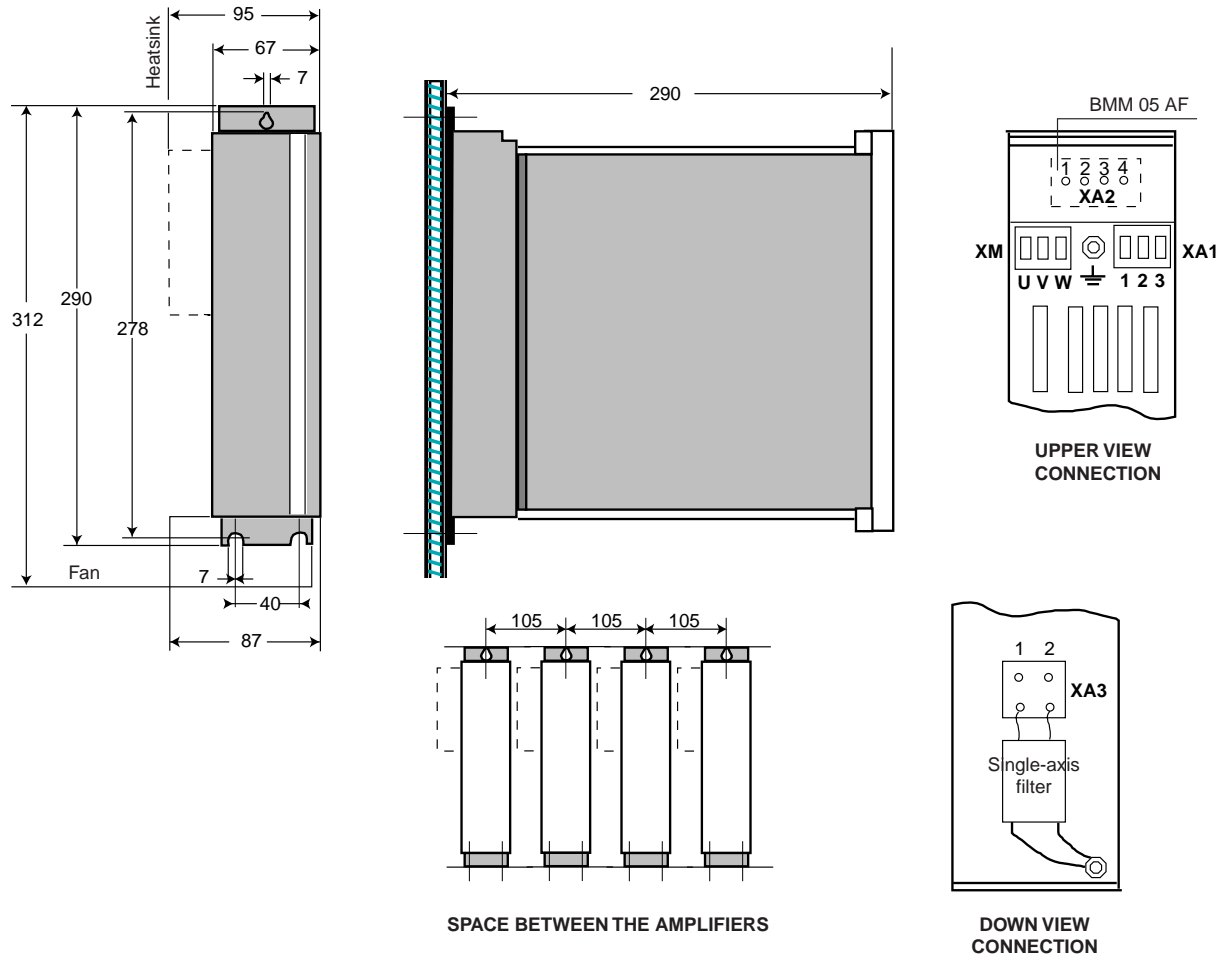

4 – RACK TYPES

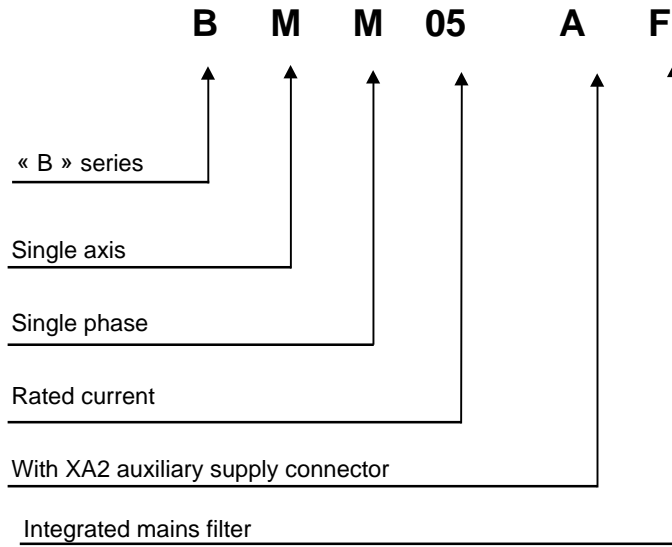

5 – BMM 05 F

5.1 – Diagram of the connector to the 230 Vac single-phase mains

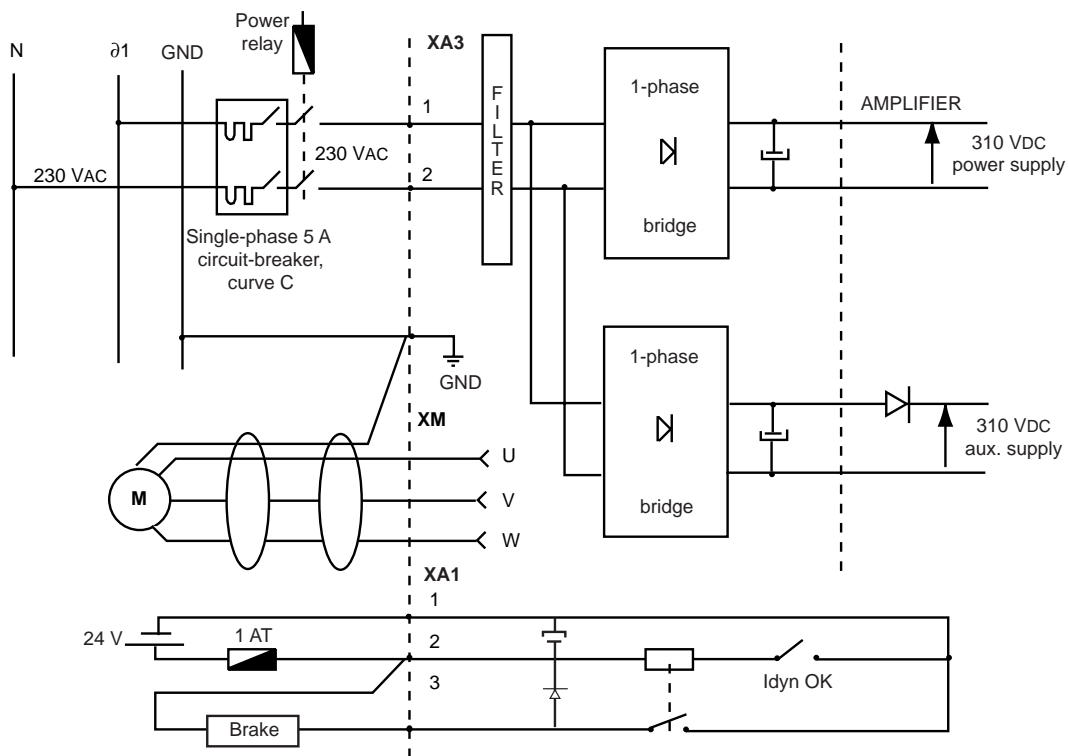

5.2 – Connections

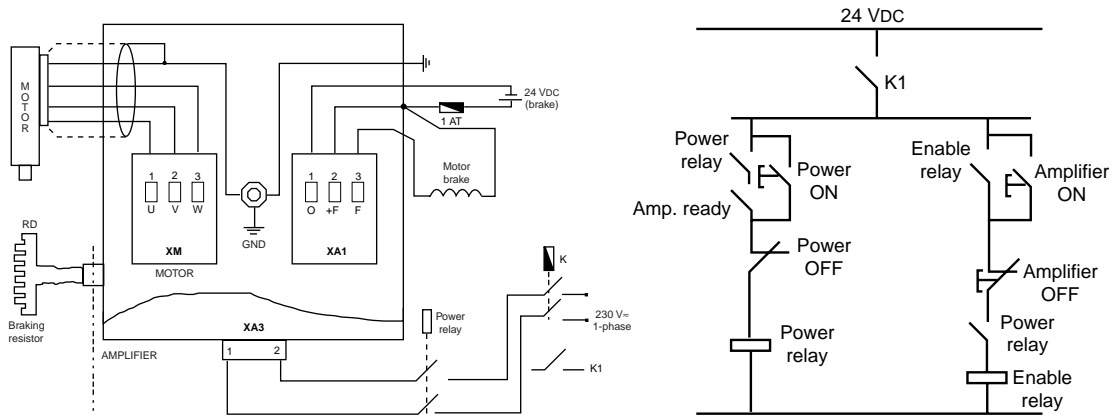

6 – BMM 05 AF

6.1 – Diagram of the connection to the 230 Vac single-phase mains

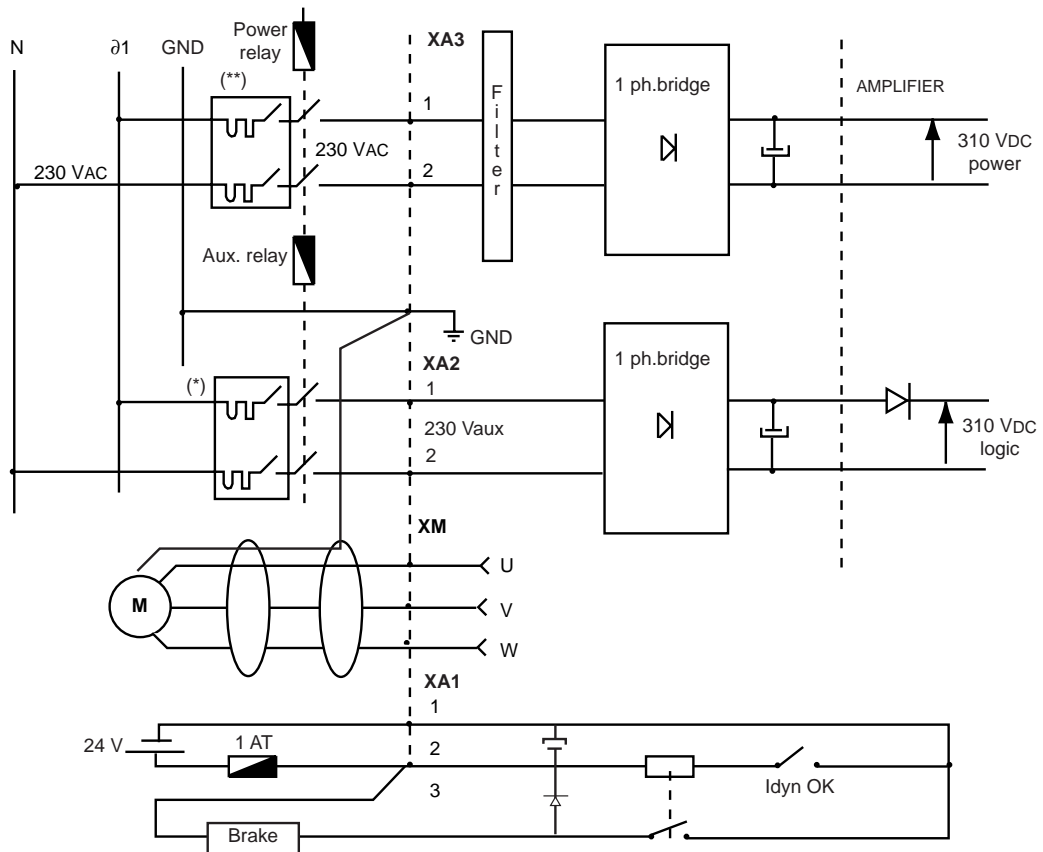

(*) 3 A single-phase circuit breaker, curve C.
 (**) 5 A single-phase circuit breaker, curve C.

SINGLE-AXIS RACKS

6.2 – Connections

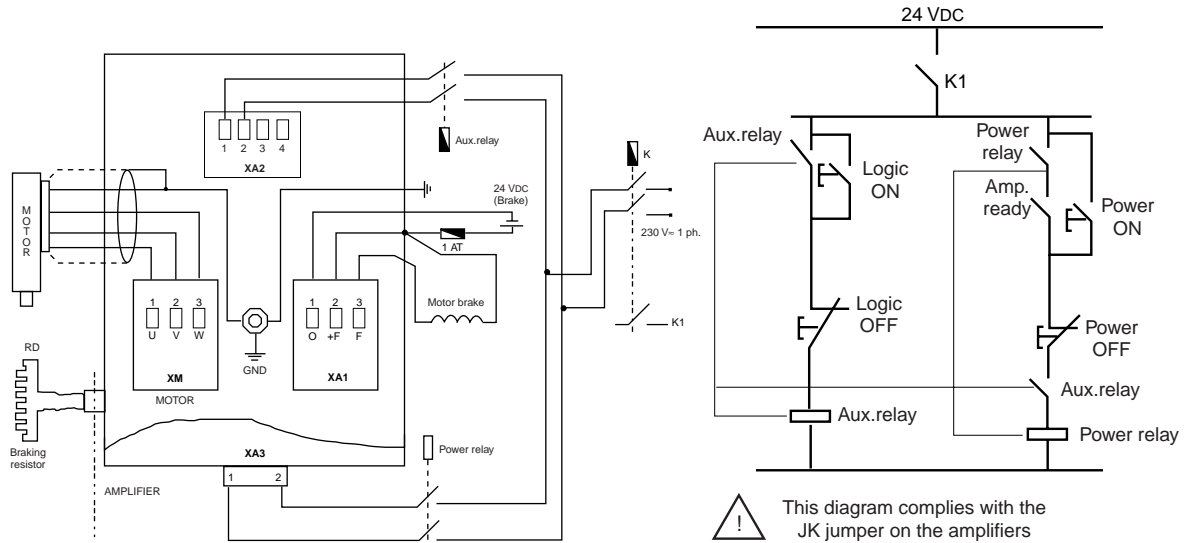

7 – CONFIGURATION

BACKPLANE CONFIGURATION FOR THE BRAKE CONTROL

The brake control can be activated by several functions of the amplifier: AMP. READY (AOK), POWER READY (POK) and IDYN READY (IDYN OK).

IDYN is the only relay directly controlled by the processor.

The AOK function includes all faults. The specific power faults are grouped on the POWER READY signal.

It is possible, by means of jumpers, to control the brake relay according to the three logic amplifier status signals below.

AOK + POK + IDYN OK	AOK + IDYN OK	IDYN OK
AB + DE + FC	AB + DC	CA

The amplifiers are delivered with configuration CA.

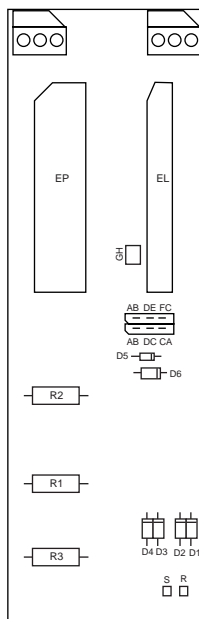

Appendix

SHIELD CONNECTION ON THE CONNECTORS

RULE

The shield must never be interrupted or corrupted over the whole cable length

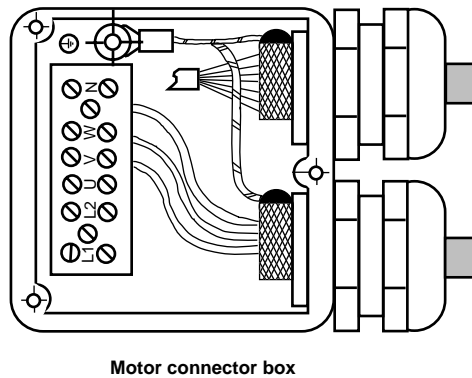
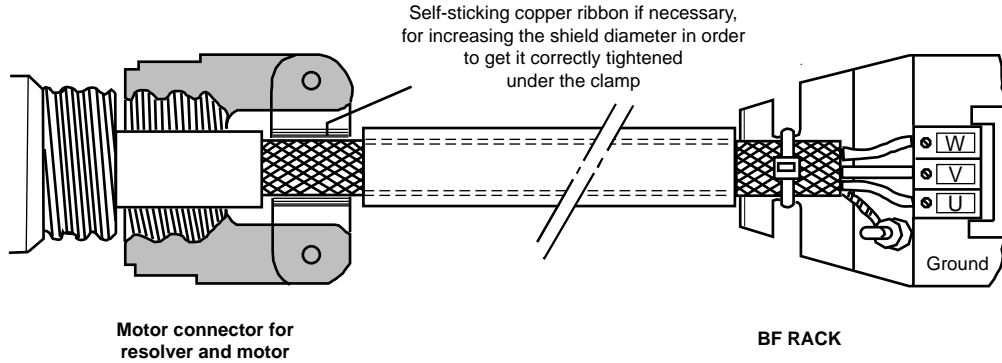

The cable can be soldered on the shield because the connector box is metallic. This solution does not exactly meet the EMC requirements but it is acceptable.

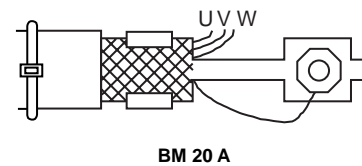
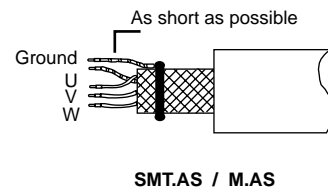
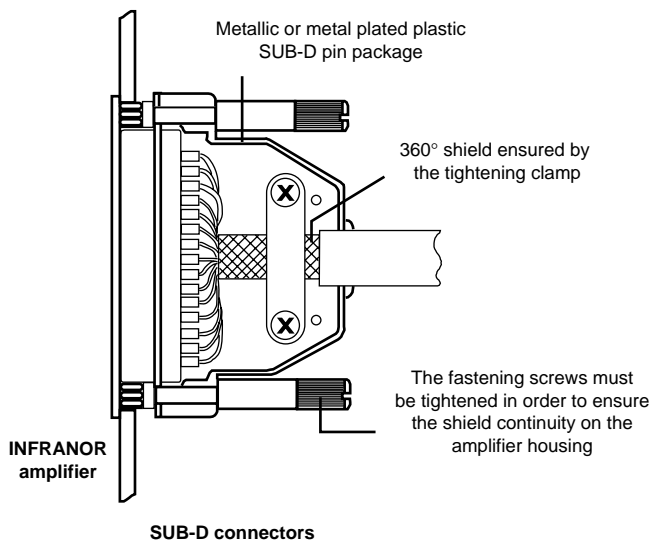

NOTE

When the 360° shield connection is made by means of a collar, it is not necessary to connect a cable on the appropriate pin of the SUB-D connector.