

Tension Brakes/High Heat Capacity

Steel Water Cooled Brakes

Cost effective design

One piece water jacket eliminates leakage

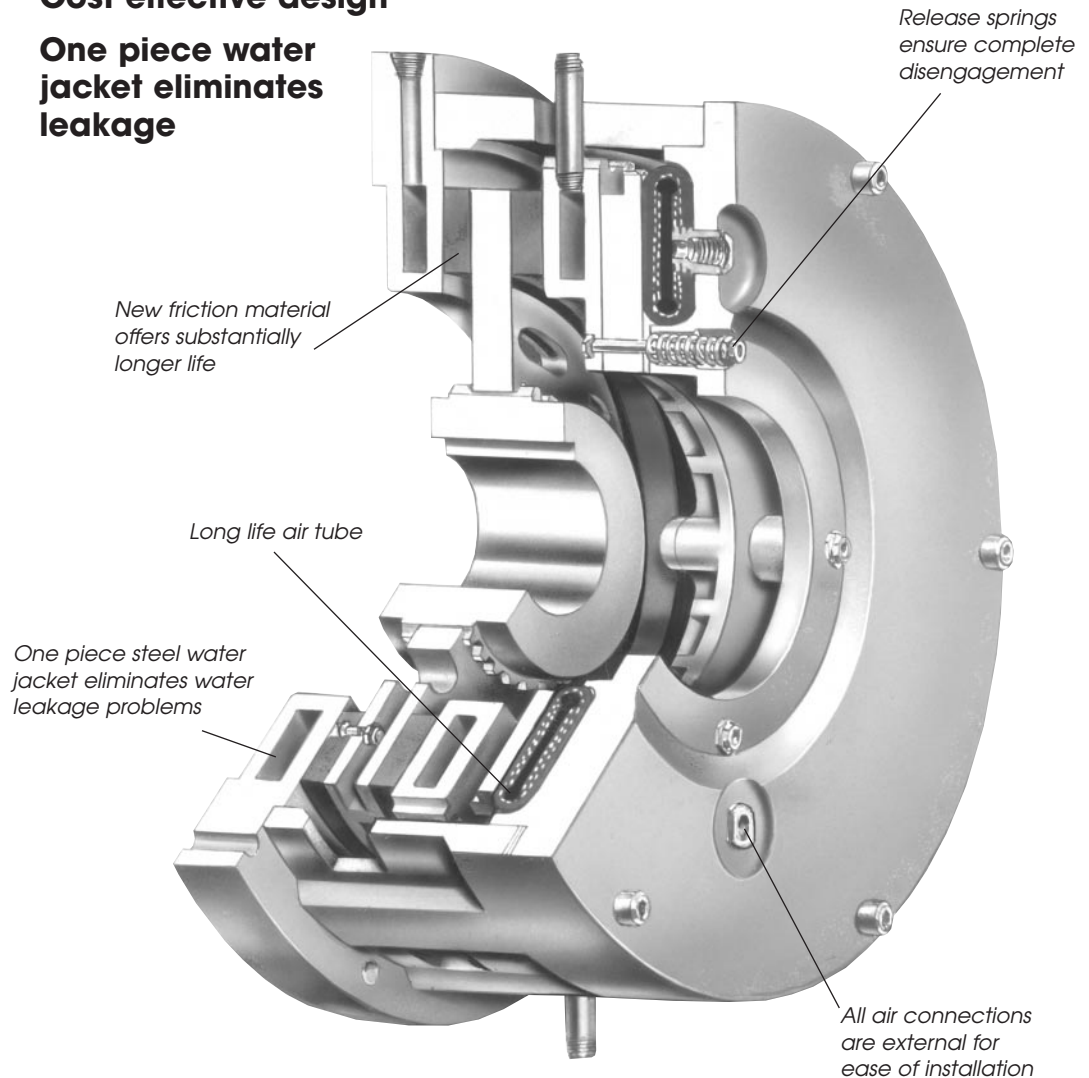

Design Features

Wichita Water Cooled Brakes provide high heat dissipation in a cost effective design. The proven airtube actuation allows precise web tension with simple air controls.

- Simple, cost effective design
- One piece steel water jacket eliminates leakage

Tension brakes are selected by calculating the thermal energy (heat) generated during unwind and choosing a brake with an equal to or greater heat dissipation rating. The brake selection becomes based on:

1. Maximum speed of roll.
2. Maximum torque needed to produce desired tension.
3. Heat capacity of brake.
4. Maximum bore capacity of brake.

Selecting a Steel Water Cooled Brake for an unwind application



To properly select a tension brake for an unwind application the following information is needed.

Max. Roll Diameter	60 in.
Max. Web Width	42 in.
Max. Web Speed	1000 fpm
Max. Tension	9 pli
Air Pressure Available	75 psi
Min. Roll Diameter	10 in.
Min. Web Width	36 in.
Min. Web Speed	900 fpm
Min. Tension	4.5 pli
Shaft Size	3.00

Calculations

Using the calculations below, consult the Steel Water Cooled Brake Specifications Chart, page 74.

The brake selected for this application is an ATD-114, with 3.5 inch bore.

$$\begin{aligned} \text{Max. Tension} &= \text{Max. pli} \times \text{Max. Web Width} \\ &= 9 \times 42 = 378 \text{ lbs.} \end{aligned}$$

$$\begin{aligned} \text{Max. Torque} &= \frac{\text{Max. Tension} \times \text{Max. Roll Dia.}}{2} \\ &= \frac{378 \times 60}{2} = 11,340 \text{ lb.in.} \end{aligned}$$

$$\begin{aligned} \text{Max. RPM} &= \frac{\text{Max. Web Speed} \times 3.82}{\text{Min. Roll Dia.}} \\ &= \frac{1,000 \times 3.82}{10} = 382 \text{ rpm} \end{aligned}$$

$$\begin{aligned} \text{Heat H.P.} &= \frac{\text{Max. Tension} \times \text{Max. Web Speed}}{33,000} \\ &= \frac{378 \times 1000}{33,000} = 11.5 \text{ Heat H.P.} \end{aligned}$$

$$\begin{aligned} \text{Min. Tension} &= \text{Min. pli} \times \text{Min. Web Width} \\ &= 4.5 \times 36 = 162 \text{ lbs.} \end{aligned}$$

$$\begin{aligned} \text{Min. Torque} &= \frac{\text{Min. Tension} \times \text{Min. Roll Dia.}}{2} \\ &= \frac{162 \times 10}{2} = 810 \text{ lb.in.} \end{aligned}$$

$$\begin{aligned} \text{Min. rpm} &= \frac{\text{Min. Web Speed} \times 3.82}{\text{Max. Roll Dia.}} \\ &= \frac{900 \times 3.82}{60} = 57 \text{ rpm} \end{aligned}$$

How to select

1. Select a brake with equal to or greater thermal capacity. The ATD-208 has 18.6 thp @ 2.8 gpm. The requirement is 11.5 thp.
2. Check torque capacity vs. required. Size ATD-208 has 10,200 lb.in. @ 100 psi. The requirement is 11,340 lb.in. Therefore an ATD-208 Brake will not produce enough torque for this application. However, an ATD-114 Brake would be the best choice.
3. Check maximum bore. The requirement is 3.00 in. The ATD-114 maximum bore is 3.5 inches.
4. Check maximum rpm. The requirement is 382 rpm. The maximum rpm for the ATD-114 is 700 rpm.

$$\begin{aligned} \text{Max. Air Pressure Required} &= \frac{\text{Max. Torque} \times 100 \text{ psi}}{\text{Catalog Torque Rating}} \\ &= \frac{11,340 \times 100}{20,300} = 56 \text{ psi} \end{aligned}$$

$$\begin{aligned} \text{Min. Air Pressure Required} &= \frac{\text{Min. Torque} \times 100 \text{ psi}}{\text{Catalog Torque Rating}} \\ &= \frac{810 \times 100}{20,300} = 4 \text{ psi} \end{aligned}$$



C

Tension Brakes/High Heat Capacity

Steel Water Cooled Brakes

Specifications

Model No. ATD-	Dynamic Slip Torque Lb.-In.		Recommended Clearances In.	Water Flow % Ethylene Glycol			Pressure Drop Parallel Flow % Ethylene Glycol		
	100 PSI	Dissipation Capacity HP		0	30	50	0	30	50
108 SWCB	5,100	9.3	1/16-1/8	1.4	1.8	2.2	0.6	0.75	0.9
208 SWCB	10,200	18.6	3/32-5/32	2.8	3.6	4.4	1.0	1.5	1.9
114 SWCB	20,300	28	1/16-1/8	4.2	5.5	6.6	1.0	1.1	1.2
214 SWCB	40,600	56	3/32-5/32	8.4	11	13.2	1.3	1.7	2.1
118 SWCB	47,000	45	1/16-1/8	6.8	9	11	1.2	1.4	1.6
218 SWCB	94,000	90	3/32-5/32	13.5	18	22	1.8	2.5	3.3
124H SWCB	113,300	95	3/32-5/32	14.2	18.5	22.2	1.9	2.5	3.4
224H SWCB	226,000	190	1/8-3/16	29	37	44.4	5.5	10	11
130 SWCB	187,000	140	3/32-5/32	21	27.5	33	1.5	1.9	2.1
230 SWCB	374,000	280	1/8-3/16	42	55	66	2.8	4.5	6.7
136 SWCB	374,000	190	3/32-5/32	29	38	45	2	2.5	3.1
236 SWCB	748,000	380	1/8-3/16	58	76	90	5	10	11

PSI Pressure Curves

The cooling water requirements are listed in the table. The pressure drop across the brakes is given for both parallel and series flow. This chart also indicates the increased flow requirement when using a mixture of ethylene glycol as an anti-freeze or for corrosion protection. The normal water requirement for steel brakes and clutches is one gallon of water for each 6.7 horsepower or one liter of water for each 1-1/3 kilowatts being dissipated. This amount of flow will give a temperature rise through the brake of 33° F. The outlet water temperature should not exceed 170° F.

The curves shown in Figure 1 and 3 indicate the pressure through the listed units for both parallel and series flow. Also shown in Figure 2 is the flow through the optional triple passage rotocouplings for clutches. The data in Figures 1, 2 and 3 will aid in estimating pressure drops for different flow requirements.

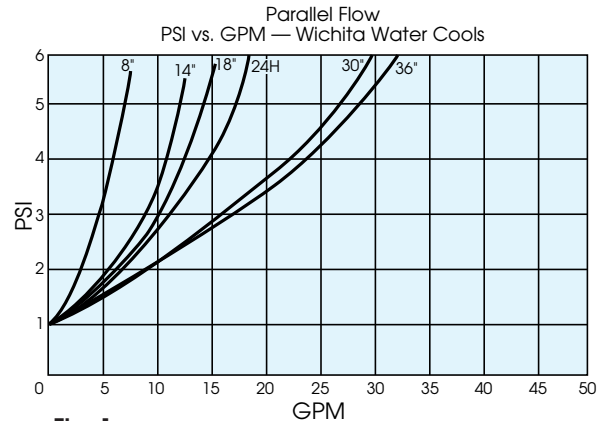

Fig. 1

An example of the use of these flow tables is:

An ATD-224H clutch is selected for 90 horsepower @ 190 RPM.

The torque requirement is 29,900 lb. in.

Water flow required = 13.5 GPM (3 inlets- 3 outlets 6.7 GPM ea.)



Model No. ATD-	Pressure Drop Series Flow % Ethylene Glycol PSI			Maximum Slip RPM For 2500 ft./Min.	Total Wt. Lb.	Hub And Disc Wt. Lb.	Hub And Disc WR ² lb. Ft ²	Maximum Lining Wear		Air Volume In ³		Water Volume In. ³
	0	30	50					In.	In. ³	New Lining	Worn Lining	
108 SWCB	1	3	3.5	1200	90	11	0.7	7/32	3	6	18	34
208 SWCB	4.2	7.5	10	1200	135	18.6	1.2	7/16	6	9	18	51
114 SWCB	3	4	6	700	275	51	1.1	5/16	13	15	43	120
214 SWCB	11	15	20	700	325	43	1.8	5/8	26	23	43	180
118 SWCB	3	4	6	550	431	79	29	5/16	21	26	56	220
218 SWCB	10	19	28	550	626	91	17	5/8	42	40	56	330
124H SWCB	11	20	28	400	725	160	64	3/8	54	60	160	540
224H SWCB	44	-	-	400	1070	250	80	3/4	108	90	160	800
130 SWCB	7	12	17	325	1245	320	200	.28	117	120	315	830
230 SWCB	37	48	-	325	1900	600	395	.56	234	180	315	1250
136 SWCB	20	24	32	265	1537	463	392	.25	140	200	415	1170
236 SWCB	-	-	-	265	2685	875	825	.50	280	300	415	1750

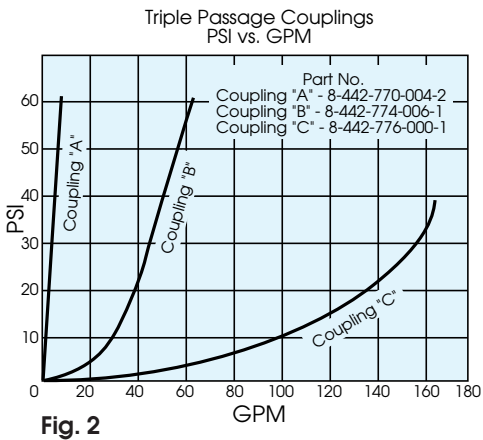

Fig. 2

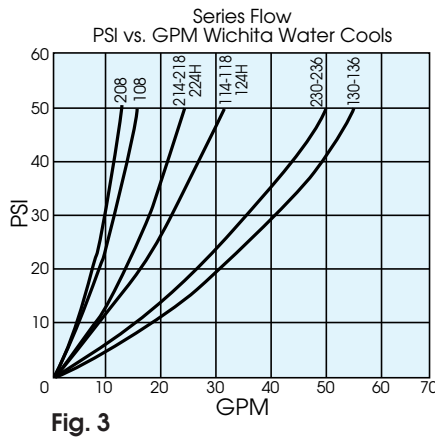
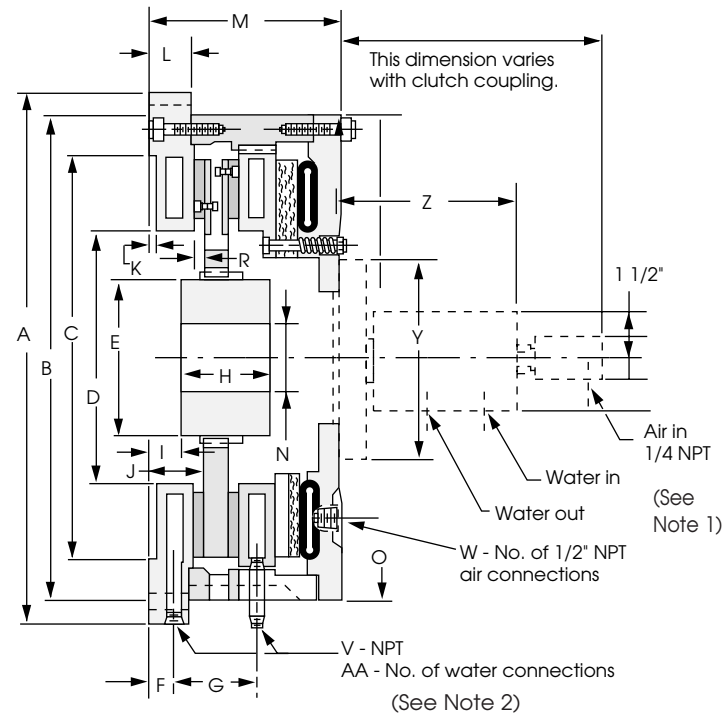
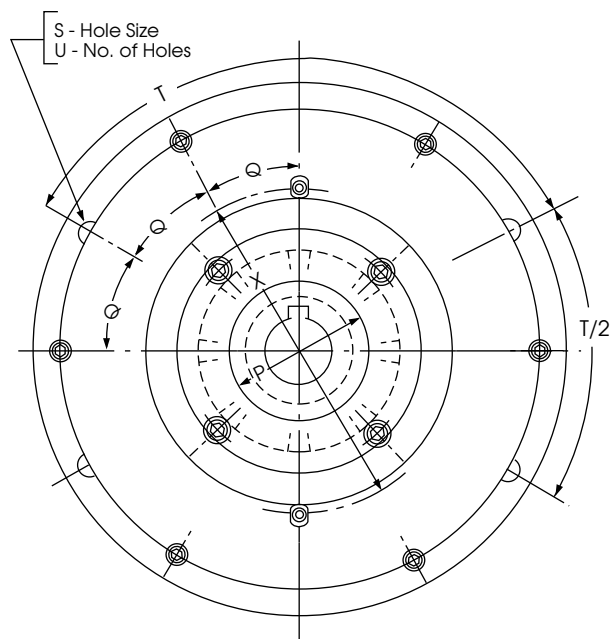

Fig. 3

From curve 1 for 6.7 GPM (24H Curve) psi the drop is 2 psi. From curve 2 for 13.5 GPM psi the drop is 2 psi. The pressure drop would be 4 psi across the inlet and outlet of coupling "B" for this application.



Steel Water Cooled Brakes



Notes:

1. Roto-couplings, see page 81.
2. Water Hose Kits, see page 78.
3. Triple passage roto-couplings, see page 80.

Dimensions (in) (Consult factory for drawing before final layout.)

Model No. ATD-	A	B	C +.000 -.003	D	E	F	G	H ±.015	I	J	K	L	M	Max.* Bore N
108 SWCB	12.125	11-1/8	8.378	4-5/8	3-1/2	15/16	3-1/8	2.000	1-1/8	2-1/16	1/4	1-1/2	6-3/4	2-1/4
208 SWCB	12.125	11-1/8	8.378	4-5/8	3-1/2	15/16	3-1/8	4.000	1-1/8	2-1/16	1/4	1-1/2	8-7/8	2-1/4
114 SWCB	18.750	17-1/2	14.378	8-7/16	5-1/2	1-1/16	4-1/8	3.750	1-1/16	2-1/2	1/4	1-3/4	8-1/2	3-1/2
214 SWCB	18.750	17-1/2	14.378	8-7/16	5-1/2	1-1/16	4-1/8	5.625	1-1/16	2-1/2	1/4	1-3/4	10-1/2	3-1/2
118 SWCB	23.250	22	18.253	11-7/16	7	1-1/16	4-1/8	4.000	1.69	2-1/2	1/4	1-3/4	8-7/8	4-3/4
218 SWCB	23.250	22	18.253	11-7/16	7	1-1/16	3-1/8	6.500	1-1/2	2-3/8	1/4	1-3/4	10-7/8	4-3/4
124H SWCB	30.000	28-3/4	24.378	13-1/2	9	1-1/16	4-3/4	4.000	1-3/8	2-3/4	1/4	1-3/4	10	6
224H SWCB	30.000	28-3/4	24.378	13-1/2	8	1-1/16	4-3/4	8.000	1-3/8	2-3/4	1/4	1-3/4	12-3/8	6
130 SWCB	37.000	35-1/2	30.378	18-1/4	10	1-3/16	5-1/2	5.000	1-3/8	2-15/16	1/4	2	11-1/16	7-1/4
230 SWCB	37.000	35-1/2	30.378	18-1/4	10	1-3/16	5-1/2	9.250	1-3/8	2-15/16	1/4	2	16-3/4	7-1/4
136 SWCB	43.500	42	36.378	22-1/2	12	1-5/16	5-1/2	5.625	1-1/8	2-15/16	1/4	2-1/4	11-7/8	9
236 SWCB	43.500	42	36.378	22-1/2	12	1-5/16	5-1/2	11.000	1-1/8	3-1/16	1/4	2-1/4	18	9

* Maximum bore uses rectangular key.

Note: For mounting, use socket head cap screws conforming to the ASTM-574-97a.

Component Parts

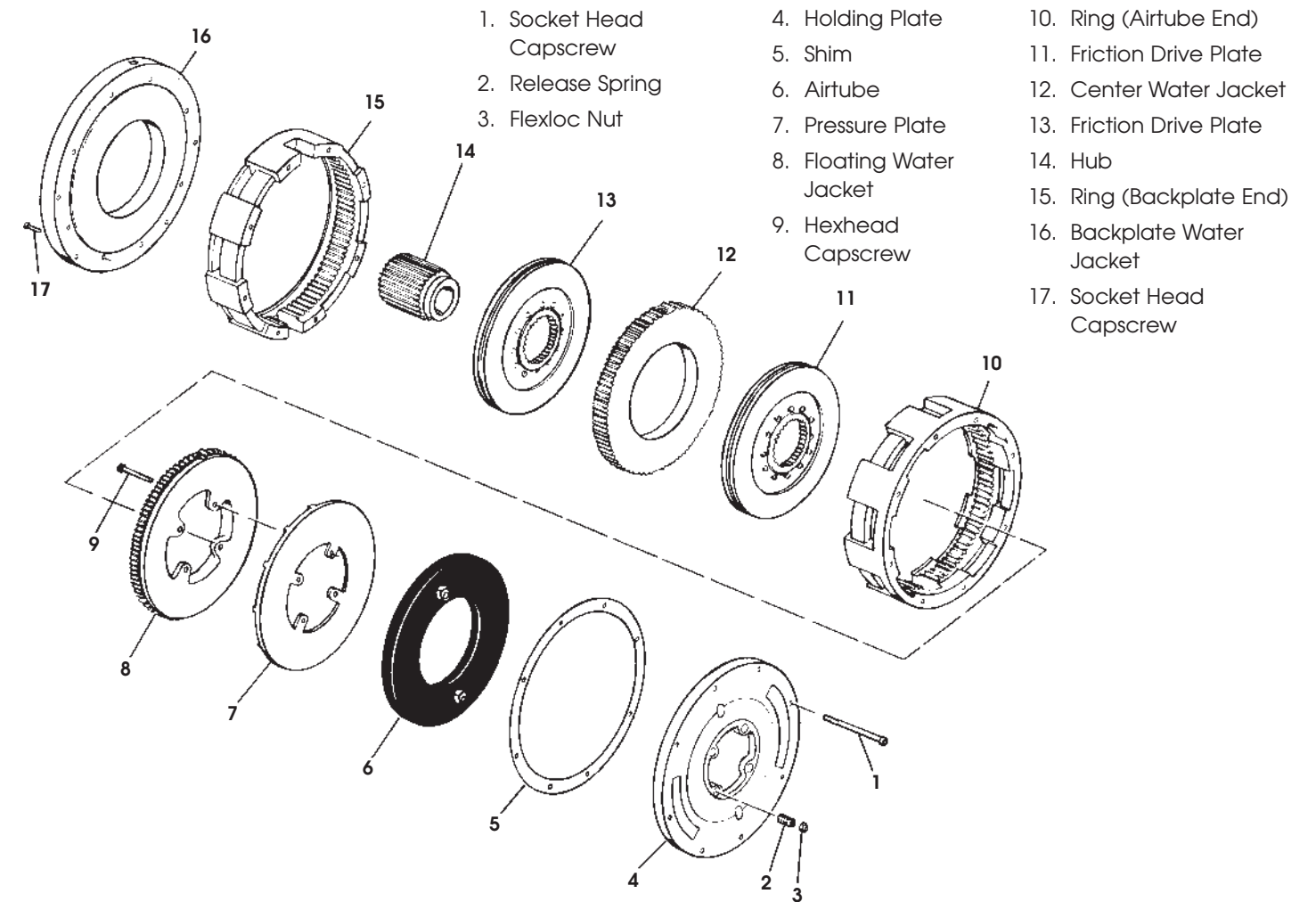

Model No. ATD-	O	P	Q	R	S	T	U	V	W	X	Y	Z	AA
108 SWCB	11-1/8	2-3/8	30	1/2	17/32	120	4	3/8	2	6-5/8	6-1/2	7-1/8	4
208 SWCB	11-1/8	2-3/8	30	1/2	17/32	120	4	3/8	2	6-5/8	6-1/2	7-1/8	6
114 SWCB	17-1/2	5	22-1/2	5/8	21/32	90	6	1/2	2	10-3/4	7-1/4	10-7/8	4
214 SWCB	17-1/2	5	22-1/2	5/8	21/32	90	6	1/2	2	10-3/4	7-1/4	10-7/8	6
118 SWCB	22	7-3/4	15	5/8	21/32	60	10	1/2	3	14-3/16	7-1/4	10-7/8	4
218 SWCB	22	7-3/4	15	5/8	21/32	60	10	1/2	3	14-3/16	7-1/4	10-7/8	6
124H SWCB	29	10-1/4	15	7/8	21/32	60	10	1/2	3	21	7-1/4	10-7/8	4
224H SWCB	29	10-1/4	15	7/8	21/32	60	10	1/2	3	21	7-1/4	10-7/8	6
130 SWCB	34-3/4	13-1/4	10	11/16	25/32	40	16	3/4	4	24-3/4	10	15-7/8	4
230 SWCB	34-3/4	13-1/4	10	11/16	25/32	40	16	3/4	4	24-3/4	10	15-7/8	6
136 SWCB	41	18-3/4	10	11/16	25/32	40	16	3/4	4	30-1/2	10	15-7/8	4
236 SWCB	41	18-3/4	10	11/16	25/32	40	16	3/4	4	30-1/2	10	15-7/8	6

Tension Brakes/High Heat Capacity

Series Water Hose Kits for Kopper Kool Brakes, KKB and Steel Water Cooled Brakes, SWCB

Wichita Water Hose kits contain all necessary fittings, hoses, and connections to completely plumb the brake water system. Customer needs to connect water input at the bottom of the brake and the output water connections at the top of the brake.

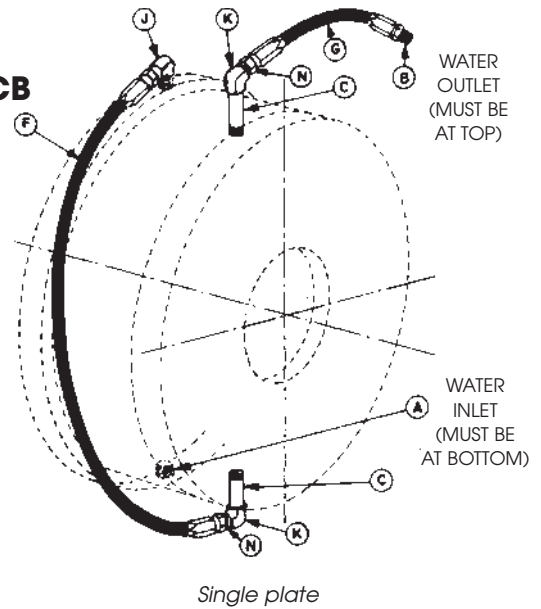

Model No. ATD-	Water Hose Kit Number*	A Inlet Size	B Inlet Size	C Pipe Nipple Part Number	Qty	D Pipe Nipple Part Number	Qty	E Pipe Nipple Part Number	Qty	F Hose Part Number	Qty	G Hose Part Number	Qty
108 KKB	8-908-999-901-5	3/8" NPT	3/8" NPT	2-200-036-122-0	2	—	—	—	—	2-403-240-033-1	1	2-403-110-133-1	1
208 KKB	8-908-999-902-5	3/8" NPT	3/8" NPT	2-200-036-122-0	4	—	—	—	—	2-403-240-033-1	2	2-403-110-133-1	1
308 KKB	8-908-999-903-5	3/8" NPT	3/8" NPT	2-200-036-122-0	6	—	—	—	—	2-403-240-033-1	3	2-403-110-133-1	1
114 KKB	8-914-999-901-6	1/2" NPT	3/4" NPT	2-200-037-122-0	2	—	—	—	—	2-404-320-044-1	1	2-404-110-144-1	1
214 KKB	8-914-999-902-6	1/2" NPT	3/4" NPT	2-200-037-122-0	4	—	—	—	—	2-404-320-044-1	2	2-404-110-144-1	1
314 KKB	8-914-999-903-6	1/2" NPT	3/4" NPT	2-200-037-122-0	6	—	—	—	—	2-404-320-044-1	3	2-404-110-144-1	1
118 KKB	8-918-999-901-6	1/2" NPT	3/4" NPT	2-200-037-122-0	2	—	—	—	—	2-404-380-044-1	1	2-404-110-144-1	1
218 KKB	8-918-999-902-6	1/2" NPT	3/4" NPT	2-200-037-122-0	4	—	—	—	—	2-404-380-044-1	2	2-404-110-144-1	1
318 KKB	8-918-999-903-6	1/2" NPT	3/4" NPT	2-200-037-122-0	6	—	—	—	—	2-404-380-044-1	3	2-404-110-144-1	1
124H SWCB	8-924-999-901-6	1/2" NPT	3/4" NPT	2-200-060-122-0	2	—	—	—	—	2-404-500-044-1	1	2-404-110-144-1	1
224H SWCB	8-924-999-902-6	1/2" NPT	3/4" NPT	2-200-060-122-0	4	—	—	—	—	2-404-500-044-1	2	2-404-110-144-1	1
324H SWCB	8-924-999-903-6	1/2" NPT	3/4" NPT	2-200-060-122-0	6	—	—	—	—	2-404-500-044-1	3	2-404-110-144-1	1
124H KKB	9-925-999-901-7	1" NPT	1" NPT	2-200-051-122-0	2	—	—	—	—	2-405-500-055-1	1	2-405-110-155-1	1
224H KKB	8-925-999-902-7	1" NPT	1" NPT	2-200-051-122-0	4	2-200-082-122-0	2	2-200-017-122-0	1	2-405-500-055-1	2	2-405-110-155-1	1
324H KKB	8-925-999-903-7	1" NPT	1" NPT	2-200-051-122-0	6	2-200-082-122-0	4	2-200-017-122-0	1	2-405-500-055-1	3	2-405-110-155-1	1
130 SWCB	8-930-999-901-7	3/4" NPT	1" NPT	2-200-061-122-0	2	—	—	—	—	2-405-620-055-1	1	2-405-200-155-1	1
230 SWCB	8-930-999-902-7	3/4" NPT	1" NPT	2-200-061-122-0	4	—	—	—	—	2-405-620-055-1	2	2-405-200-155-1	1
330 SWCB	8-930-999-903-7	3/4" NPT	1" NPT	2-200-061-122-0	6	—	—	—	—	2-405-620-055-1	3	2-405-200-155-1	1
130 KKB	8-930-999-901-9	1" NPT	1-1/2" NPT	2-200-062-122-0	2	—	—	—	—	2-407-620-077-1	1	2-407-200-177-1	1
230 KKB	8-930-999-902-9	1" NPT	1-1/2" NPT	2-200-062-122-0	4	2-200-092-122-0	2	2-200-017-122-0	1	2-407-620-077-1	4	2-407-200-177-1	1
330 KKB	8-930-999-903-9	1" NPT	1-1/2" NPT	2-200-062-122-0	6	2-200-092-122-0	4	2-200-017-122-0	1	2-407-620-077-1	3	2-407-200-177-1	1
136 SWCB	8-936-999-901-7	3/4" NPT	1" NPT	2-200-061-122-0	2	—	—	—	—	2-405-680-055-1	1	2-405-200-155-1	1
236 SWCB	8-936-999-902-7	3/4" NPT	1" NPT	2-200-061-122-0	4	—	—	—	—	2-405-680-055-1	2	2-405-200-155-1	1
336 SWCB	8-936-999-903-7	3/4" NPT	1" NPT	2-200-061-122-0	6	—	—	—	—	2-405-680-055-1	3	2-405-200-155-1	1
136H KKB	8-937-999-901-9	1-1/4" NPT	1-1/2" NPT	2-200-063-122-0	2	—	—	—	—	2-407-680-077-1	1	2-407-200-155-1	1
236H KKB	8-937-999-902-9	1-1/4" NPT	1-1/2" NPT	2-200-063-122-0	4	2-200-104-122-0	2	2-200-018-122-0	1	2-407-680-077-1	2	2-407-200-155-1	1
336H KKB	8-937-999-903-9	1-1/4" NPT	1-1/2" NPT	2-200-063-122-0	6	2-200-104-122-0	4	2-200-018-122-0	1	2-407-680-077-1	3	2-407-200-155-1	1

* Denotes complete hose kit



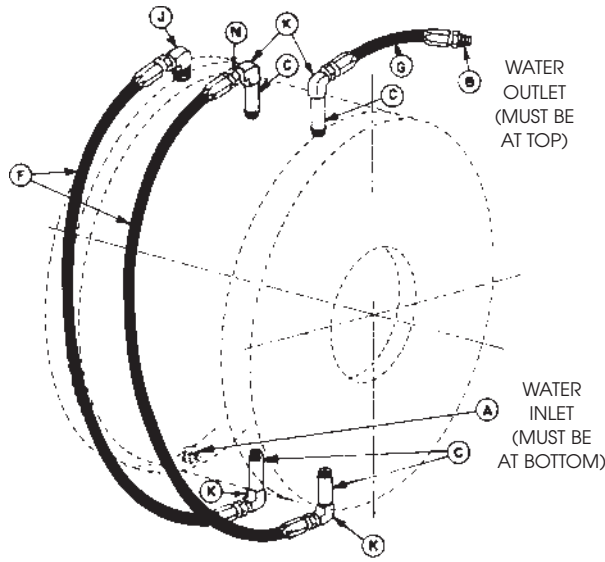

Double Plate
 Sizes 208 through 318

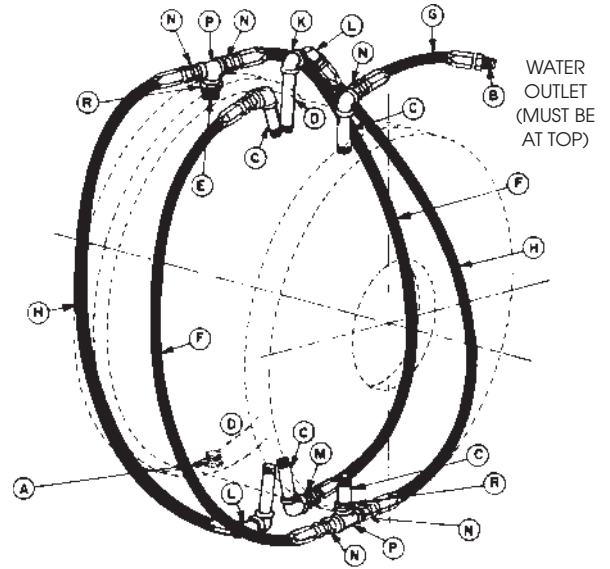

Double Plate
 Sizes 224H through 336H

Model No.	ATD-	H Hose Part Number	Qty	J Elbow 90 Part Number	Qty	K Elbow 90 Part Number	Qty	L Elbow 45 Part Number	Qty	M Adaptor Part Number	Qty	N Adaptor Part Number	Qty	P Pipe Tee Part Number	Qty
108 KKB	—	—	—	2-303-027-020-0	1	2-302-027-020-0	2	—	—	—	—	—	—	—	—
208 KKB	—	—	—	2-303-027-020-0	1	2-302-027-020-0	4	—	—	—	—	—	—	—	—
308 KKB	—	—	—	2-303-027-020-0	1	2-302-027-020-0	6	—	—	—	—	—	—	—	—
114 KKB	—	—	—	2-303-039-020-0	1	2-302-039-020-0	2	—	—	—	—	—	—	—	—
214 KKB	—	—	—	2-303-039-020-0	1	2-302-039-020-0	4	—	—	—	—	—	—	—	—
314 KKB	—	—	—	2-303-039-020-0	1	2-302-039-020-0	6	—	—	—	—	—	—	—	—
118 KKB	—	—	—	2-303-039-020-0	1	2-302-039-202-0	4	—	—	—	—	—	—	—	—
218 KKB	—	—	—	2-303-039-020-0	1	2-302-039-202-0	6	—	—	—	—	—	—	—	—
318 KKB	—	—	—	2-303-039-020-0	1	2-302-039-202-0	4	—	—	—	—	—	—	—	—
124H SWCB	—	—	—	2-303-039-020-0	1	2-302-039-202-0	6	—	—	—	—	—	—	—	—
224H SWCB	—	—	—	2-303-039-020-0	1	2-302-039-202-0	6	—	—	—	—	—	—	—	—
324H SWCB	—	—	—	2-303-062-001-0	1	2-302-062-001-0	2	—	—	—	—	—	—	—	—
124H KKB	2-405-500-055-1	2	—	—	—	2-302-062-001-0	5	2-307-062-001-0	2	2-300-062-001-0	2	2-300-062-001-0	5	2-214-041-412-0	2
224H KKB	2-405-500-055-1	3	—	—	—	2-302-062-001-0	9	2-307-062-001-0	4	2-300-062-001-0	4	2-300-062-001-0	5	2-214-041-412-0	2
324H KKB	—	—	—	2-303-051-001-0	1	2-210-036-112-0	2	—	—	—	—	—	—	2-300-062-001	2
130 SWCB	—	—	—	2-203-051-001-0	1	2-210-036-112-0	4	—	—	—	—	—	—	2-300-062-001-0	4
230 SWCB	—	—	—	2-303-064-001-0	1	2-210-041-112-0	6	—	—	—	—	—	—	2-300-062-001-0	6
330 SWCB	—	—	—	2-303-064-001-0	1	2-210-041-112-0	2	—	—	—	—	—	—	2-300-064-001-0	2
130 KKB	—	—	—	2-210-041-112-0	5	2-307-064-001-0	2	2-300-064-001	2	2-300-064-001-0	5	2-214-041-112-0	2	—	—
230 KKB	—	—	—	2-407-620-077-1	3	2-210-041-112-0	9	2-307-064-001-0	4	2-300-064-001-0	4	2-300-064-001-0	5	2-214-041-112-0	29
330 KKB	—	—	—	2-303-051-001-0	1	2-210-036-112-0	2	—	—	—	—	—	—	2-300-062-001-0	2
136 SWCB	—	—	—	2-303-051-001-0	1	2-210-036-112-0	4	—	—	—	—	—	—	2-300-062-001-0	4
236 SWCB	—	—	—	2-303-051-001-0	1	2-210-036-112-0	6	—	—	—	—	—	—	2-300-062-001-0	6
336 SWCB	—	—	—	2-303-075-001-0	1	2-210-046-112-0	2	—	—	—	—	—	—	2-300-075-001-0	2
136H KKB	2-407-660-077-1	2	—	—	—	2-210-046-112-0	5	2-300-075-001-0	2	2-300-075-001-0	2	2-300-075-001-0	5	2-214-073-112-0	2
236H KKB	2-407-660-077-1	3	—	—	—	2-210-046-112-0	9	2-300-075-001-0	4	2-300-075-001-0	4	2-300-075-001-0	5	2-214-073-112-0	2
336H KKB	—	—	—	—	—	—	—	—	—	—	—	—	—	—	—

C

3-Way Roto-Coupling (for water-cooled Clutches)

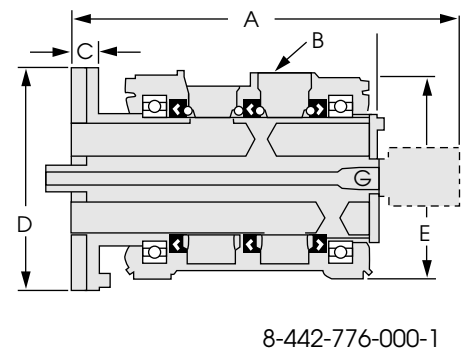
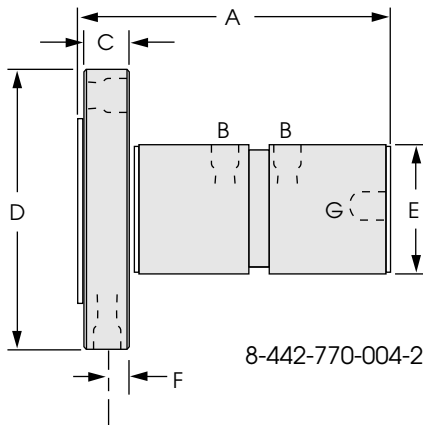
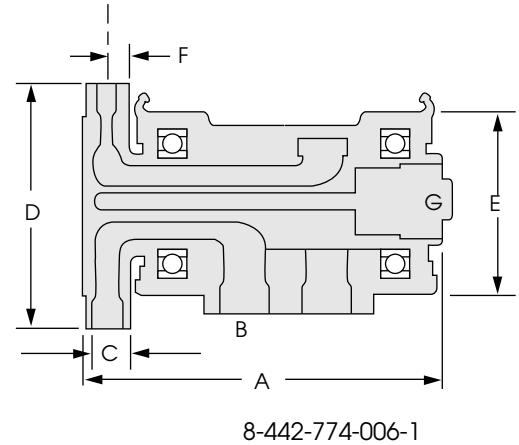
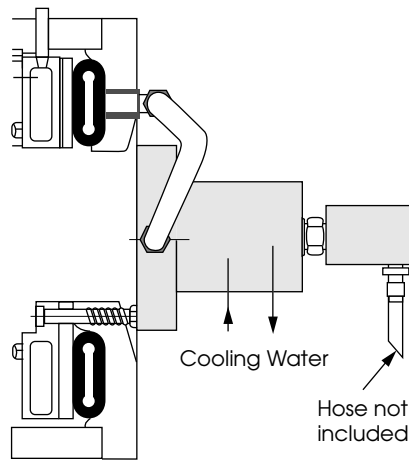

Dimensions

Wichita Part No.	A	B	C	D	E	F	Thread Size	
							G	H
8-442-770-004-2	7-1/4"	3/8"-18 NPT	1"	6-1/2"	3"	1/2"	5/8"-18	—
8-442-774-006-1	11"	1-1/4"-11-1/2 NPT	1-3/8"	7-1/4"	5-3/8"	11/16"	1/4" NPT	—
8-442-776-000-1	18-7/8"	2"-11-1/2 NPT	1-1/4"	10"	9"	—	1"-14	3-3/4"





Roto-couplings

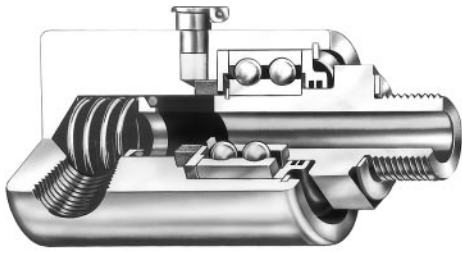

- Long life, low maintenance.
- Felt seal eliminates bearing contamination.
- Fast, easy installation.

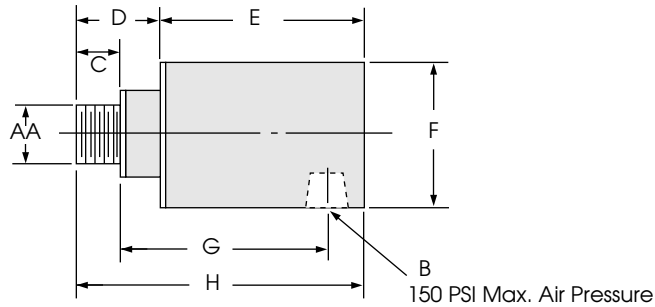

The Wichita Roto-coupling is a device to connect, or couple, a non-rotating air, gas, or fluid line to a rotating shaft.

Wichita Part No.	AA	B	C	D	E	F	G	H	Max. R.P.M.
8-240-701-003-1	5/8-18NF	1/4" NPT	.40	1.046	2.250	1.500	2.13	3.297	3500
8-240-705-001-1	1"-14 NF	1/2" NPT	.75	1.250	3.188	2.500	3.00	4.438	3500
8-240-708-001-1	1"-14 NF	3/4" NPT	.75	1.313	4.688	2.875	3.69	5.440	3500
8-240-710-002-1	1-1/2"-12 NF	1" NPT	1.13	1.937	4.875	3.250	3.44	6.812	2500
8-240-712-001-1	2"-12 NF	1-1/2" NPT	1.13	2.813	5.250	4.250	5.38	8.062	2500
8-240-714-001-3	2" NPT	2" NPT	1.50	3.000	7.062	4.625	7.00	10.062	1000
8-240-716-000-3	2-1/2" NPT	2-1/2" NPT	1.88	3.250	9.375	7.000	7.75	12.625	750

Notes: All measurements are in inches.

Principle of Operation

Closed Cooling System

As shown here in the closed loop system, flexible water lines should be brought into each jacket at the 6 o'clock position. When the Kopper Kool Unit is used as a clutch, air vent tubes must be installed internally at the factory to insure proper filling of the water jackets. The Kopper Kooled Clutches also require 5 PSI back pressure on the outlet side of the triple passage rotocoupling to insure complete evacuation of air from these jackets during rotation.

Referring to the closed loop cooling system, the equipment should be protected with low water pressure and high temperature warning devices. For availability information, contact factory.

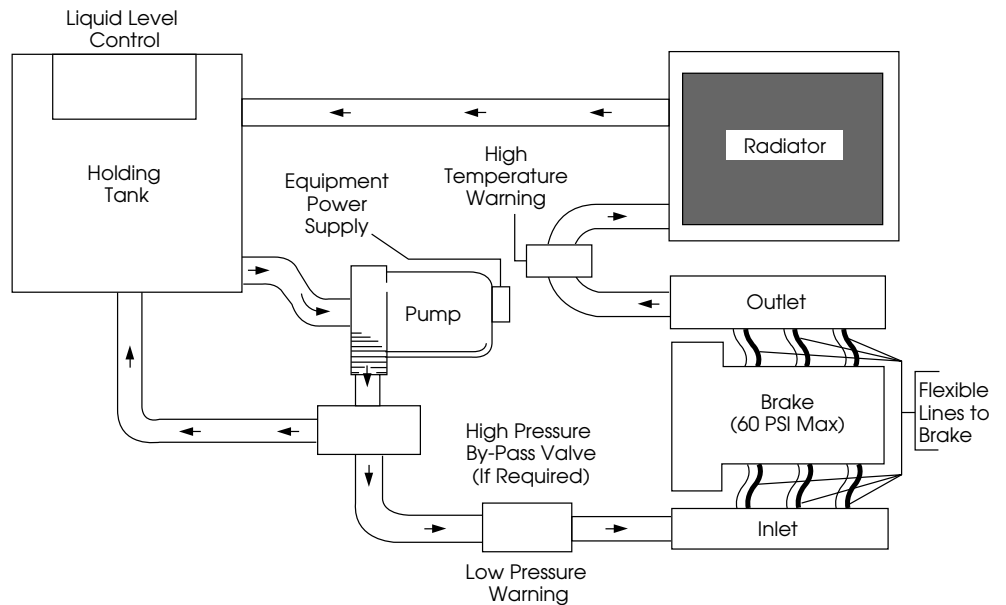

C