

Welcome To

bostongear.com



Enclosed Gear Drives

New!

Open Gearing

BostSpec2



Material Handling

Boston

Gear

Power Transmission Products



MEX (55) 53 63 23 31 MTY (81) 83 54 10 18
QRO (442) 1 95 72 60 ventas@industrialmagza.com

Check us out at www.bostongear.com

Give your business a head start today with instant online access to a vast resource of power transmission product information.

The BostSpec2 eCATALOG lets you start your search for basic types of equipment then move quickly to choices which match your needs for function, torque, horsepower, output RPMs, mounting and other requirements. Select from thousands of models, all detailed with downloadable 2D and 3D CAD drawings, dimensional drawings and PDF pages.



**In a hurry?
BostSpec2 is the quick and easy
way to find the product that's
right for your application**

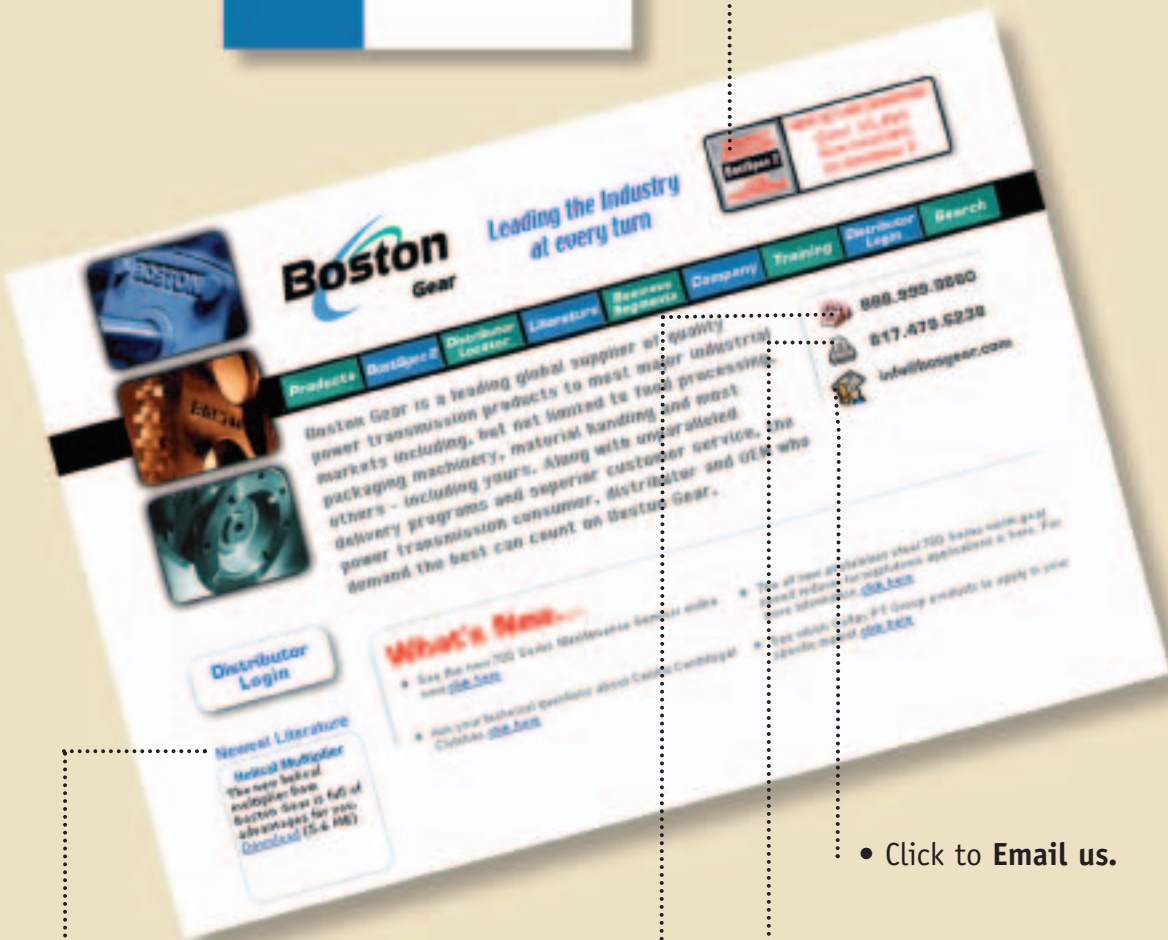

• **Download** the newest literature.

• **Click to Email us.**

• **Fax us.**

• **Call us — Toll Free!**



MEX (55) 53 63 23 31 MTY (81) 83 54 10 18
QRO (442) 1 95 72 60 ventas@industrialmagza.com

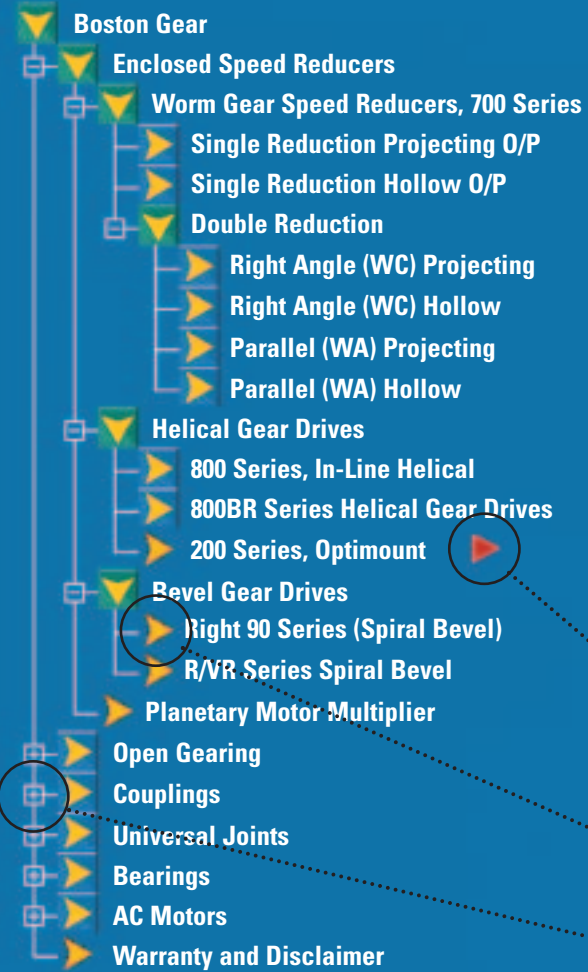

Use BostSpec2, the online product selector, to find the product that will fulfill your power transmission application needs

with just a few clicks...



Easy to use Product Index Navigation

- Click to **advance** to Part Number specific information.
- Click to **view** Product Overview.
- Click to **expand** the Product List.

Search And Find The Product Family That's Right For Your Application



Not sure how to navigate your way through the thousands of available part numbers to download on BostSpec2? Use our new BostSpec2 online tutorial. Listen to the audio while viewing an active desktop go through the motions. You'll see how to register for the eCatalog, how to download a part number, submit an RFQ and select an authorized Boston Gear distributor.



The online tutorial, "How to use BostSpec2", can be accessed by clicking on the BostSpec2 logo or mousing over the "BostSpec2" or "Training" buttons located in the navigation bar on the home page.

Click the yellow "Question Mark" icon on the registration page. Then just watch and learn - it's easy.



Once you've found the right product family, you can quickly access specific product line information such as product features and configurations with just a single click.

Use the Product Selector

2



Part Search

If you know the part number, simply type it in and go directly to the specification page. Use the description box for general words and phrases (gears).

By choosing appropriate product attributes or model numbers, BostSpec2 also lets you select the precise model to meet your specific power transmission requirements.

Refine Your Search Criteria



Ratio

- ✓ 5
- 10
- 15
- 20
- 25
- 30
- 40
- 50

Torque Capacity

- ✓ 99
- 120
- 123
- 128
- 130
- 132
- 202
- 238
- 243
- 258
- 261

Boston Gear Product Tree Part Search RFQ List

700 Series Propelling Output Shaft

Ratio: Torque Cap (L-B):

Motor HW Class: Output RPM @150:

Add to RFQ Cart	View Spec Sheet	Part Number	Ratio	Torque Cap (L-B)	Bore Code	Motor HP (Class)	Fan Cooled Rating?
<input type="button" value="Add"/>	<input type="button" value="Spec"/>	F710-10-B4-G	10	123	B4-40CZ	1/3	NO
<input type="button" value="Add"/>	<input type="button" value="Spec"/>	F710-10-B5-G	10	123	B5-58C	1/3	NO
<input type="button" value="Add"/>	<input type="button" value="Spec"/>	F710-15-B4-G	15	128	B4-40CZ	1/4	NO
<input type="button" value="Add"/>	<input type="button" value="Spec"/>	F710-15-B5-G	15	128	B5-58C	1/4	NO
<input type="button" value="Add"/>	<input type="button" value="Spec"/>	F710-20-B4-G	20	130	B4-40CZ	1/4	NO
<input type="button" value="Add"/>	<input type="button" value="Spec"/>	F710-20-B5-G	20	130	B5-58C	1/4	NO
<input type="button" value="Add"/>	<input type="button" value="Spec"/>	F710-30-B4-G	30	132	B4-40CZ	1/6	NO
<input type="button" value="Add"/>	<input type="button" value="Spec"/>	F710-30-B5-G	30	132	B5-58C	1/6	NO
<input type="button" value="Add"/>	<input type="button" value="Spec"/>	F710-40-B4-G	40	128	B4-40CZ	1/6	NO
<input type="button" value="Add"/>	<input type="button" value="Spec"/>	F710-40-B5-G	40	128	B5-58C	1/6	NO
<input type="button" value="Add"/>	<input type="button" value="Spec"/>	F710-50-B4-G	50	120	B4-40CZ	1/6	NO
<input type="button" value="Add"/>	<input type="button" value="Spec"/>	F710-50-B5-G	50	120	B5-58C	1/6	NO
<input type="button" value="Add"/>	<input type="button" value="Spec"/>	F710-5-B4-G	5	99	B4-40CZ	1/3	NO
<input type="button" value="Add"/>	<input type="button" value="Spec"/>	F710-5-B5-G	5	99	B5-58C	1/2	NO
<input type="button" value="Add"/>	<input type="button" value="Spec"/>	F710-10-B5-G	10	243	B5-58C	3/4	NO
<input type="button" value="Add"/>	<input type="button" value="Spec"/>	F710-15-B5-G	15	261	B5-58C	1/2	NO
<input type="button" value="Add"/>	<input type="button" value="Spec"/>	F710-20-B5-G	20	264	B5-58C	1/3	NO
<input type="button" value="Add"/>	<input type="button" value="Spec"/>	F710-25-B5-G	25	258	B5-58C	1/3	NO

Motor HP

- ✓ 1/6
- 1/4
- 1/3
- 1/2
- 3/4
- 1
- 1-1/2
- 2
- 3

Output RPM

- NO
- ✓ 29.2
- NO
- 35
- NO
- 43.8
- NO
- 58.2
- NO
- 58.3
- NO
- 70
- NO
- 87.5
- NO
- 116.7

View and Download Specifications

Simply click the button to access complete specifications for the model selected. Dimensional drawings, 2D & 3D CAD drawings, PDF pages and printer friendly specs are also downloadable.

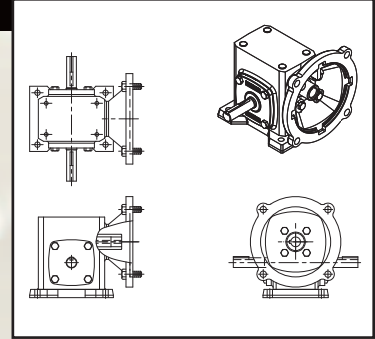
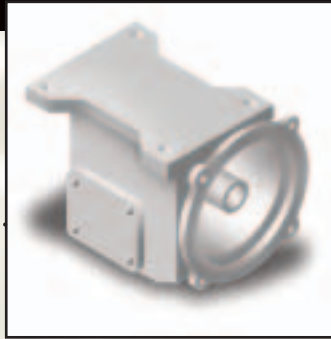

4

Product Family: 700 SERIES
Part Number: E719A&B-D-1

Download Drawing
3D CAD
PDF Link

CAD Drawing Not Available

Specifications:	
Description	177R SR RED. 54 PA170 "A" WOOD BASE, "J" ASSY
Reduction	SINGLE
Output Shaft	PROJECTING O/P
Frame	"A" WOOD BASE
Input Style	ODRLL
Fan Cooled Rating?	NO
Output RPM @1750	1500
Ratio	5
Shaft Assembly Code	J
Tongue Cap (L.R. #)	330
Base Code	B7 - 54TC198C
Motor I/P (Class 9)	2
Change	Yes

5

Submit An RFQ

Just click the **RFQ list** button located at the top of every page to generate an Email-based or faxable Request For Quotation (RFQ) to be sent directly to your choice of authorized distributor.

Request for Quote CART

Part Number	Description	Qty
E719A-D-1	700 Series	1

Request for Quote CART

Request for Quote CART



Drop In and Explore

The Boston Gear web site has been designed to provide a better on-line experience. Easy, intuitive drop-down navigation requires fewer clicks to get to the information you need.

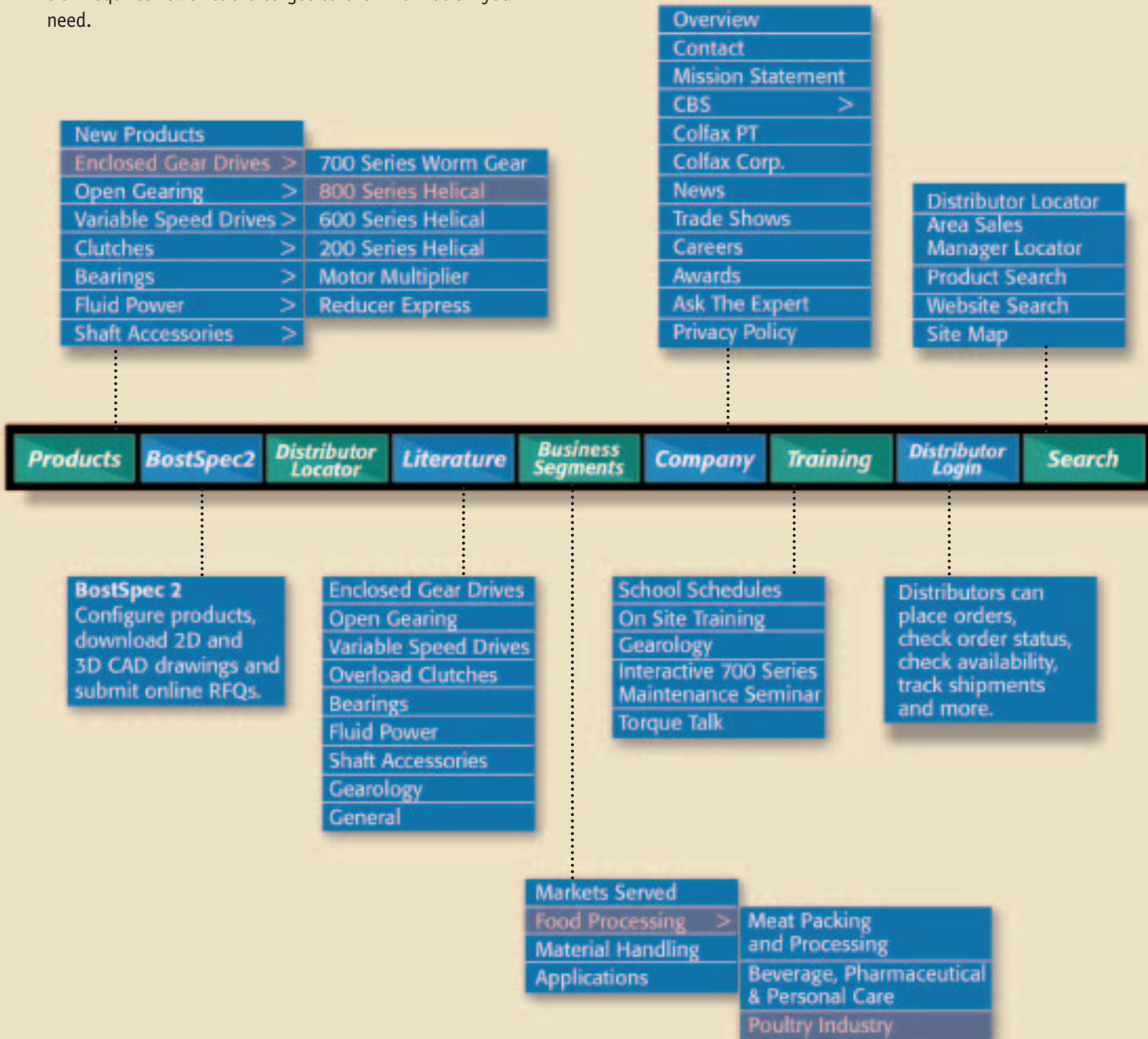

Colfax PT Group

Colfax Power Transmission Group

Quincy, MA 02171
617-328-3300

Warner Electric

Electromagnetic Clutches and Brakes - USA

South Beloit, IL 61080
1-800-389-3771

For Application Assistance:
1-800-825-9050

Electromagnetic Clutches and Brakes - Europe

Allonnes, France
+33 (0)2 43 43 63 63

Precision Electric Coils - USA

Columbia City, IN 46725
260-244-6183

Boston Gear

Enclosed and Open Gearing, Electrical and Mechanical PT Components

Quincy, MA 02171
617-328-3300

For Customer Service:
1-888-999-9860

For Application Assistance:
1-800-816-5608

Formsprag Clutch - Stieber Clutch - USA

Overrunning Clutches and Holdbacks

Warren, MI 48089
586-758-5000

For application assistance:
1-800-825-9050

Stieber Clutch - Formsprag Clutch - Europe

Overrunning Clutches and Holdbacks

Heidelberg, Germany
+49 (0)6221 30 47 0

For Application Assistance:
1-800-816-5608

Marland Clutch

Roller Ramp and Sprag Type Overrunning Clutches and Backstops

Burr Ridge, IL 60527
708-352-3330

Nuttall Gear and Delroyd Worm Gear

Worm Gear and Helical Speed Reducers

Niagara Falls, NY 14302
716-731-5180

Wichita Clutch and Industrial Clutch

Pneumatic and Oil Immersed Clutches and Brakes - USA

Wichita Falls, TX 76302
940-723-3400

Pneumatic Clutches and Brakes - Europe

Bedford, UK
+44 (0)1234 350311

Ameridrives Couplings

Gear Couplings, Mill Spindles, Universal Joints

Erie, PA 16512
814-480-5000

Colfax Power Transmission Group - Asia Pacific

China	852 2615 9313
Taiwan	886 2 2577 8156
Singapore	65 487 4464
Thailand	66 2 322 0481
Australia	612 9894 0133

Food Processing



Variable Speed Drives



14 Hayward Street • Quincy, MA 02171
617-328-3300 • Fax: 617-479-6238
www.bostongear.com



MEX (55) 53 63 23 31 MTY (81) 83 54 10 18
QRO (442) 1 95 72 60 ventas@industrialmagza.com

Printed in USA