

# Single-Phase Adjustable Speed, DC Motor Controllers 1/12 through 3 HP

- 1/12 - 3 HP
- 115 or 230 V, Single Phase
- Tach Feedback
- Reversing Models
- Current Limit
- Compact Size
- Budget Priced
- Flexible — Modifiable with Standard Options
- NEMA 1 or NEMA 12 Enclosed Models
- Open Chassis Models
- Local and Remote Control Models
- UL Listed or UL Recognized



## MODEL TYPES

Series DCX units are offered in enclosed or open chassis configurations in nine (9) standard models in four (4) functional groups as shown in Tables 1 and 2. Chassis units are ideal for the OEM or panel builder who may want to build a custom system by integrating

the controller in an enclosure with special logic or auxiliary control devices. Enclosed units are offered as complete self-contained, functional packages which include power conversion and regulator electronics. AC line protection and integral operator controls.

**TABLE 1: DCX UNENCLOSED CHASSIS UNITS WITHOUT OPERATOR CONTROLS (1)**

HORSEPOWER RANGE (5)		CATALOG NUMBER	ITEM CODE	FUNCTION (3)
115V	230V			
1/12-1/2	—	DCX102C	65984	Run-Stop
1/12-1/2 1/12-1 (2)	1/2-1 1/2-2 (2)	DCX202C	65985	Run-Stop
1/12-1	1/2-3	DCX302C	65986	Run-Stop

- NOTES: (1) DCX Units are furnished with a potentiometer rated 5K ohms, 1/2 watt for separate mounting.  
 (2) Requires either option DCX-RHTSK for 1 HP on 115 VAC and 2 HP on 230 VAC or option DCX-HTSK for 3/4 HP on 115 VAC and 1-1/2 HP on 230 VAC.  
 (3) Armature contactor Run-Stop-DB, and contactor reversing and dynamic braking are provided by Options DCX-DA and DCX-RA.  
 (4) Panel assembly models do not include an enclosure. They are intended for mounting on a door or other panel surface through an aperture cut into the User's NEMA 1 or NEMA 12 enclosure.  
 (5) Units may be easily recalibrated for any standard rating within the range of the product using trim pots.

**TABLE 2: DCXplus ENCLOSED UNITS WITH OPERATOR CONTROLS**

HORSEPOWER RANGE (5)		CATALOG NUMBER	ITEM CODE	TYPE (4)	FUNCTION
115V	230V				
1/12-1/2	1/2-1	DCX202EP	65987	NEMA 1 Panel Assembly	Run-Stop
1/12-1/2	1/2-1	DCX202E	65988	NEMA 1 Enclosed	Run-Stop
1/12-1/2	1/2-1	DCX202EN12	65990	NEMA 12 Enclosed	Run-Stop
1/12-1/2	1/2-1	DCX202ERP	65991	NEMA 1 Panel Assembly	Run-Stop-Reverse
1/12-1/2	1/2-1	DCX202ER	65992	NEMA 1 Enclosed	Run-Stop-Reverse
1/12-1/2	1/2-1	DCX202ERIN12	65995	NEMA 12 Enclosed	Run-Stop-Reverse

## DESIGN FEATURES AND FUNCTIONS

- Enclosed Models** — These units are furnished in a compact, die cast aluminum, nonventilated enclosure. NEMA 1 and NEMA 12 models are offered. See Figure 3 for NEMA 1 and Figure 4 for NEMA 12 model dimensions. The complete control assembly is mounted on the front panel which can be removed from the enclosure by removing screws. The unenclosed panel assembly can be mounted through a cut-out in the user's enclosure, see Figure 5 for cut-out dimensions.
- Chassis Models** — The units are furnished as a very compact open chassis consisting of the regulator/power conversion circuit board mounted to a formed aluminum chassis. Some models may be furnished with a supplemental heatsink (Options DCX-RHTSK & DCX-HTSK) to improve heat dissipation and thereby extend the horsepower range. Chassis units are dimensionally interchangeable with many competitive units. See Figure 1 for dimensions of Models DCX102C and DCX202C. See Figure 2 for dimensions of Model DCX302C.
- Full-Wave Power Conversion** — NEMA Code K converter configuration formed of discrete devices rated 600 PIV. Converter consists of two (2) SCR's, two diodes and a free wheeling diode which provide optimum form factor for best motor performance and long service. Enclosed models use the control enclosure as an integral heatsink with the power control devices electrically isolated from the enclosure.
- Voltage Transient Protection** — Metal oxide suppressor across the AC line minimizes the effect of high voltage spikes from the AC power source.
- Tachometer Feedback** — All standard units except Model DCX102C include tabs to accept a 35, 50 or 100 VDC/1000 RPM feedback signal from a motor mounted DC tachometer generator for improved speed regulation as shown in Table 4 (Unidirectional units only).
- Horsepower Selection** — Easily calibrated by built-in trim pots to suit individual motor horsepower ratings without special instruments, or plug-in shunts.
- Wiring Terminals** — Enclosed models are provided with barrier terminal strips for all external power and signal wires. Chassis models are provided with male tab wiring connectors. A terminal strip is offered as Options DCXBTB-2, DCXBTB-3 or DCX-FBK.
- AC Line Fuse** — Enclosed models include a fuse holder for an AC line fuse mounted on the circuit board. Chassis units do not include a fuse as standard, but a fuse holder may be provided with Options DCXBTB-2, DCXBTB-3 or DCX-FBK.
- Operator Controls** — All enclosed models include integral operator controls consisting of a speed setting potentiometer and an ON-OFF AC line power switch. Switch is maintained in ON and OFF positions. Reversing models additionally include a 3-position FORWARD-STOP-REVERSE maintained switch. Switch includes a no pass through center detent which provides anti-plug protection.  
  
Chassis units are controlled by external, customer furnished switches, pushbuttons, or control logic. Includes an inhibit circuit for automatic operation by switch, relay or PLC.
- Line Voltage Selection** — Line voltage selection is automatic without the use of jumpers or switches.
- Field Supply** — A full-wave, transient protected motor field supply is provided.

## OPERATING CONDITIONS

- Line Voltage Variation** ..... ±10% of rated
- Line Frequency Variation** ..... ±2 Hz
- Ambient Temperature**  
**Open Chassis Models** ..... 0 to 50°C  
 (32°F to 122°F)  
**Enclosed Models** ..... 0 to 40°C  
 (32°F to 104°F)
- Altitude (Standard)** ..... 3300 feet  
 (1000 meters) maximum

## RATINGS

- Service Factor** ..... 1.0
- Duty** ..... Continuous
- Overload Capacity (armature circuit)** ..... 150% for 1 minute
- Operating Voltages** ..... See Table 3
- Run Speed Potentiometer** ..... 5k ohms, 1/2W
- Horsepower Range** ..... See Tables 1 and 2
- Reference Power Supply (1)** ..... 10VDC
- Line Fuse (2)** ..... Provided by others

### NOTES:

- Units are optionally adaptable for use with 4-20 mA, and 0-10 VDC.
- A line fuse holder is provided as standard on DCXplus Models. Fuse clips are optional on all other models.

TABLE 3. OPERATING VOLTAGES

POWER SOURCE (single-phase)	OUTPUT VDC	
	Armature	Field
115V, 50 or 60 Hz	0-90	100
230 V, 50 or 60 Hz	0-180	200

## ADJUSTMENTS

- Current Limit** ..... 0-150% full-load torque (typical)
- Maximum Speed** ..... 60-100% of motor base speed
- Minimum Speed** ..... 0-40% of motor base speed
- IR (load) Compensation** ..... 0-100% of rated load
- Acceleration/Deceleration (1)** ..... 0-100% of rated load

### NOTES:

- DCX102C acceleration/deceleration is 1.0 second fixed rate.

## PERFORMANCE CHARACTERISTICS

- Controlled Speed Range** – Zero to motor base speed. Speed range with respect to the specified regulation is as listed in Table 4. See Catalog for continuous duty application limitations of DC Motors.
- Speed Regulation** – (See Table 4) - Regulation percentages listed are of motor base speed under steady-state conditions. Normal operation will result in performance equal to or better than specified.
- Efficiency (Rated Speed/Rated Load)**  
 (a) Controller SCR regulator ..... 99%  
 (b) Complete drive with motor (typical) ..... 85%

TABLE 4. SPEED REGULATION CHARACTERISTICS

REGULATION METHOD	Load Change 95%	Line Voltage ±10%	Field Heating Cold/Normal	Temperature ±10°C	SPEED RANGE
Standard Voltage Feedback with IR Compensation	2%	±1%	5-12%	±2%	30:1
Optional Speed (Tach) Feedback (1)	1%	±1%	0.2%	±2%	100:1

(1) Unidirectional models only.

## RATINGS AND CHARACTERISTICS

TABLE 5. TYPICAL APPLICATION DATA

			RATINGS									
RATED HORSEPOWER (HP)			1/12	1/6	1/4	1/3	1/2	3/4	1	1-1/2	2	3
RATED KILOWATTS (kW)			0.062	0.124	0.187	0.249	0.373	0.560	0.746	1.129	1.492	2.238
1-PHASE AC INPUT (FULL-LOAD)	Line Amps	115V Unit	2.0	3.9	5.0	6.0	8.7	12.4	15.0	–	–	–
		230V Unit	–	–	–	–	4.8	5.9	8.8	12.6	15.8	24.0
	KVA		.30	.48	.58	.71	1.0	1.4	2.0	3.0	4.0	6.0
DC OUTPUT (FULL-LOAD)	Motor Armature Amps	90V	0.9	2.0	2.8	3.5	5.4	8.1	10.5	–	–	–
		180V	–	–	–	–	2.5	3.8	5.5	8.2	11.6	16.0
	Motor Field Amps	100V	1.0	1.0	1.0	1.0	1.0	1.0	1.0	–	–	–
		200V	–	–	–	–	1.0	1.0	1.0	1.0	1.0	1.0
Full-Load Torque (Lb-ft) with 1750 RPM Base Speed Motors			.25	0.5	0.75	1.0	1.5	2.2	3.0	4.5	6.0	9.0

## DIMENSIONS

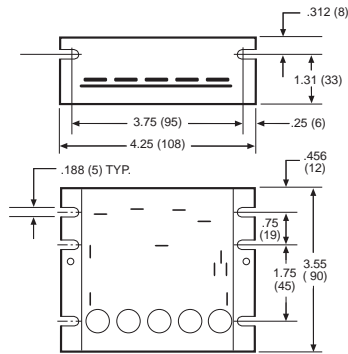

FIGURE 1. DCX102C and DCX202C Dimensions

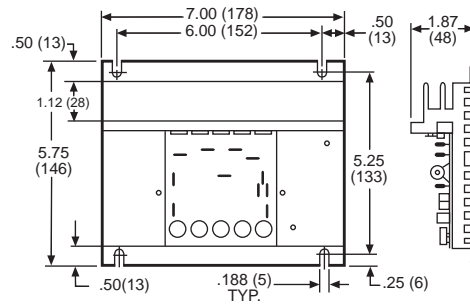

FIGURE 2. DCX302C Dimensions

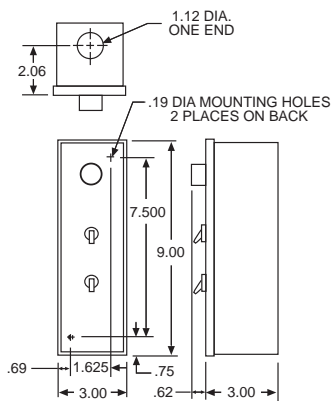

FIGURE 3. DCXplus NEMA 1 Dimensions

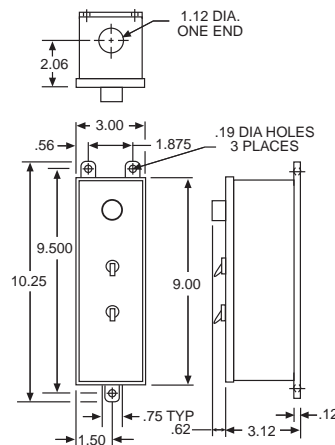

FIGURE 4. DCXplus NEMA 12 Dimensions

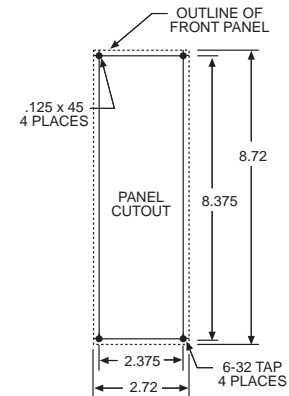
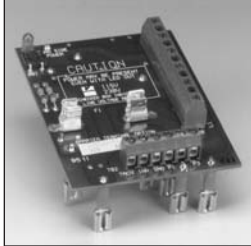
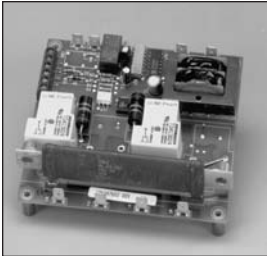
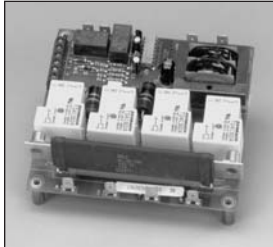
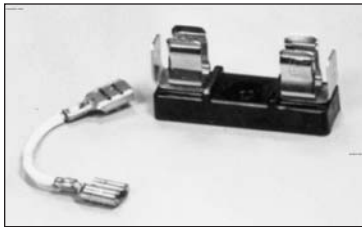

FIGURE 5. DCXplus Panel Mounting Cut-Out Dimensions

## OPTION DESCRIPTIONS

The versatility of DCX Series chassis configuration controllers is further expanded by selecting one or more of the following options:

### OPTIONS

Option Number	Description																																																																						
<b>DCXBTB-2 (68249)</b> <b>DCXBTB-3 (68254)</b>	<p><b>Barrier Terminal Board</b>                      Kit includes screw terminals for all external wiring, one line fuse holder, and an LED power on indicator in an assembly that plugs piggy-back onto chassis model units. <i>(fuse not included).</i></p> <table border="1"> <thead> <tr> <th>OPTION</th> <th>INPUT VOLTAGE</th> <th>HORSEPOWER RATING</th> </tr> </thead> <tbody> <tr> <td>DCXBTB-2</td> <td>115 VAC</td> <td>1</td> </tr> <tr> <td>DCXBTB-3</td> <td>230 VAC</td> <td>3</td> </tr> </tbody> </table> 	OPTION	INPUT VOLTAGE	HORSEPOWER RATING	DCXBTB-2	115 VAC	1	DCXBTB-3	230 VAC	3																																																													
OPTION	INPUT VOLTAGE	HORSEPOWER RATING																																																																					
DCXBTB-2	115 VAC	1																																																																					
DCXBTB-3	230 VAC	3																																																																					
<b>DCX-DA (65996)</b>	<p><b>Contactor, Two-Pole with Dynamic Braking</b>                      The basic DCX Series chassis controller is designed for Run-Stop unidirectional operation without an armature contactor. This option provides a two-pole armature contactor which is necessary whenever the application requires a positive disconnection of the rectified armature power source from the motor on a stop command. Action of the contactor is sequenced with the SCR regulator to ensure that the DC power circuit is “phased-off” before the contactor is opened. This results in “Dry switching” for improved contactor longevity. This option also includes dynamic braking which provides exponential rate braking of the DC motor armature. Included is a DB resistor with an anti-plug circuit to prevent restarting the controller until the braking cycle is complete, thereby preventing a potentially damaging electrical surge and mechanical stress.</p>  <p><b>DYNAMIC BRAKING RESISTOR RATINGS</b></p> <table border="1"> <thead> <tr> <th rowspan="2">COMPONENT</th> <th rowspan="2">UNIT</th> <th colspan="10">RATED HORSEPOWER</th> </tr> <tr> <th>1/12</th> <th>1/6</th> <th>1/4</th> <th>1/3</th> <th>1/2</th> <th>3/4</th> <th>1</th> <th>1-1/2</th> <th>2</th> <th>3</th> </tr> </thead> <tbody> <tr> <td>Braking</td> <td>115V</td> <td>250</td> <td>180</td> <td>129</td> <td>103</td> <td>66</td> <td>44</td> <td>34</td> <td>–</td> <td>–</td> <td>–</td> </tr> <tr> <td>Torque %</td> <td>230V</td> <td>–</td> <td>–</td> <td>–</td> <td>–</td> <td>278</td> <td>190</td> <td>130</td> <td>88</td> <td>62</td> <td>44</td> </tr> <tr> <td>Stops Per</td> <td>115V</td> <td>18</td> <td>15</td> <td>12</td> <td>11</td> <td>8</td> <td>6</td> <td>2</td> <td>–</td> <td>–</td> <td>–</td> </tr> <tr> <td>Minute</td> <td>230V</td> <td>–</td> <td>–</td> <td>–</td> <td>–</td> <td>8</td> <td>6</td> <td>1</td> <td>1</td> <td>1</td> <td>1</td> </tr> </tbody> </table> <p>This option permits motor Start/Stop operation by pushbuttons or external logic in 115 or 230 VAC applications.</p> <p><i>The DB resistor is rated for stopping a typical load, when the external machine inertia does not exceed that of the motor armature, as shown in the table.</i></p>	COMPONENT	UNIT	RATED HORSEPOWER										1/12	1/6	1/4	1/3	1/2	3/4	1	1-1/2	2	3	Braking	115V	250	180	129	103	66	44	34	–	–	–	Torque %	230V	–	–	–	–	278	190	130	88	62	44	Stops Per	115V	18	15	12	11	8	6	2	–	–	–	Minute	230V	–	–	–	–	8	6	1	1	1	1
COMPONENT	UNIT			RATED HORSEPOWER																																																																			
		1/12	1/6	1/4	1/3	1/2	3/4	1	1-1/2	2	3																																																												
Braking	115V	250	180	129	103	66	44	34	–	–	–																																																												
Torque %	230V	–	–	–	–	278	190	130	88	62	44																																																												
Stops Per	115V	18	15	12	11	8	6	2	–	–	–																																																												
Minute	230V	–	–	–	–	8	6	1	1	1	1																																																												
<b>DCX-RA (65998)</b>	<p><b>Reversing, Armature with Dynamic Braking</b>                      This option is the same as DCX-DA except two double pole contactors are provided for reversing the DC motor armature rated 1 HP at 90 VDC armature or 3 HP at 180 VDC maximum. Anti-plug protection is provided to prevent armature reversal until a safe minimum speed is attained. The direction of motor rotation is controlled by external RUN/FORWARD-REVERSE pushbuttons, switches or logic. Braking times are same as DCX-DA above.</p> 																																																																						
<b>DCX-FBK (67114)</b>	<p><b>Fuse Block Kit</b>                      Kit includes a fuse block, lead wire with spade connectors, and mounting screw. This option provides external line fuse protection for DCX Series chassis controllers <i>(fuse not included).</i></p> 																																																																						

## OPTION DESCRIPTIONS (CONTINUED)

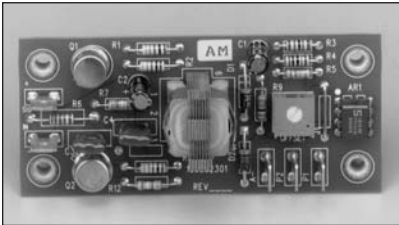
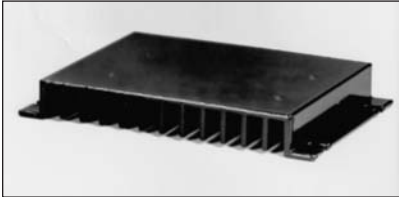
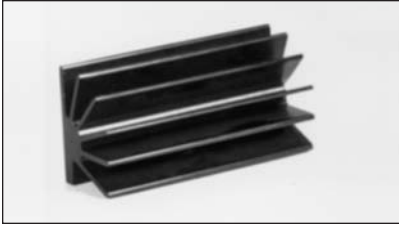
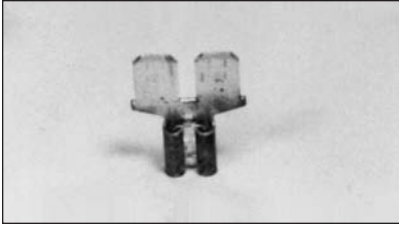
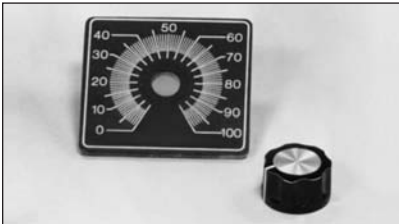
Option Number	Description						
<b>DCX-25A (68342)</b>	<p><b>Follower, External Signal</b>                      This option is intended as a low cost alternative which offers greater accuracy and flexibility. The option is capable of operating from the following isolated or nonisolated signals: 4-20 DC ma, 0-10 VDC. <i>This option includes a scaling potentiometer for offset adjustment.</i></p> <p>Dimensions 1.5" (38) X 3.38" (86) X .75" (19)</p> 						
<b>DCX-HTSK (67106)</b>	<p><b>Heatsink Kit (Flat)</b>                      This option consists of an extruded aluminum heatsink and hardware to mount a Model DCX202C controller. This heatsink is intended for use only with Model DCX202C where its greater heat dissipation permits increasing the units original rated horsepower.</p> <p>Dimensions: 4.44" (113) X 6.75" (171) X .88" (22)</p> <table border="1" data-bbox="334 827 743 924"> <thead> <tr> <th>INPUT VOLTAGE</th> <th>HORSEPOWER RATING</th> </tr> </thead> <tbody> <tr> <td>115 VAC</td> <td>3/4</td> </tr> <tr> <td>230 VAC</td> <td>1-1/2</td> </tr> </tbody> </table> 	INPUT VOLTAGE	HORSEPOWER RATING	115 VAC	3/4	230 VAC	1-1/2
INPUT VOLTAGE	HORSEPOWER RATING						
115 VAC	3/4						
230 VAC	1-1/2						
<b>DCX-RHTSK (67098)</b>	<p><b>Heatsink Kit (Radial)</b>                      This option provides the same function as Option DCX-HTSK except it is a unique space saving radial design and offers a greater horsepower rating.</p> <p>Dimensions: 2" (51) X 1.38" (35) X 4.25" (108)</p> <table border="1" data-bbox="334 1142 743 1239"> <thead> <tr> <th>INPUT VOLTAGE</th> <th>HORSEPOWER RATING</th> </tr> </thead> <tbody> <tr> <td>115 VAC</td> <td>1</td> </tr> <tr> <td>230 VAC</td> <td>2</td> </tr> </tbody> </table> 	INPUT VOLTAGE	HORSEPOWER RATING	115 VAC	1	230 VAC	2
INPUT VOLTAGE	HORSEPOWER RATING						
115 VAC	1						
230 VAC	2						
<b>DCX-DP (67118)</b>	<p><b>Dual Connector Terminal Adapter</b>                      This option provides a two (male) into one (female) push-on terminal to facilitate connection of DCX Series units for tachometer feedback and/or inhibit.</p> 						
<b>DCX-KDP (67109)</b>	<p><b>Knob and Dial Plate Kit</b>                      The option provides a knob and a dial face graduated 0-100% for use with the potentiometer provided with DCX Series units.</p> 						

---

Distributed by



Imo Industries Inc.  
**Boston Gear Division**  
14 Hayward Street  
Quincy, MA 02171  
617-328-3300  
FAX: 617-479-6238

***Your Source for Motion Control Products***



MEX (55) 53 63 23 31 MTY (81) 83 54 10 18  
QRO (442) 1 95 72 60 [ventas@industrialmagza.com](mailto:ventas@industrialmagza.com)

(64102)  
Printed in U.S.A.  
Copyright © Boston Gear, 1995