

# Boston Gear®

## CBF22A and CBF50A

### Clutch/Brake Modules

819-0395

### *Installation and Operation*

Doc. No. 83442

CBF22A  
CBF50A

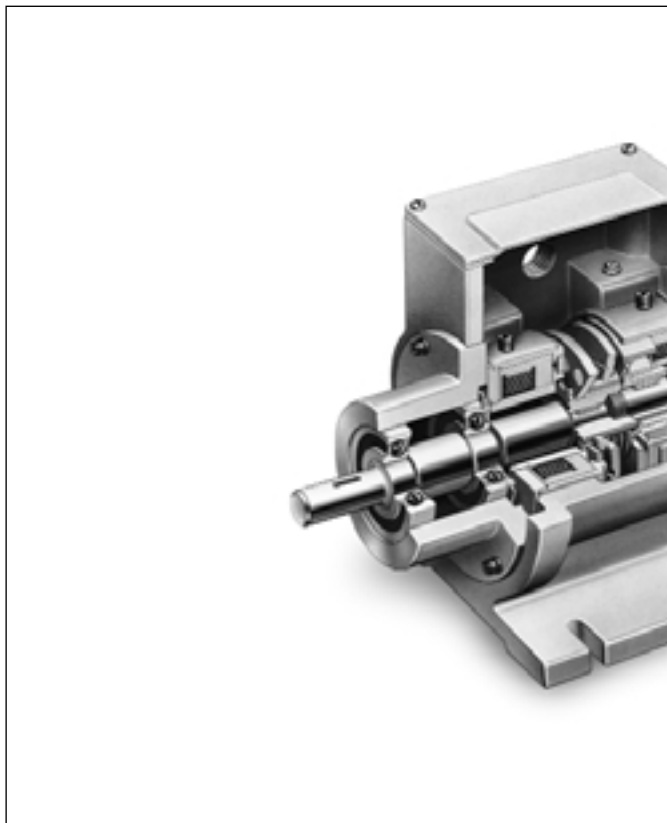

**Boston**  
Gear

[www.bostongear.com](http://www.bostongear.com)

## CONTENTS

Installation Instructions . . . . .	2-4
Burnishing and Maintenance . . . . .	4-5
Dimensions . . . . .	6
Replacement Parts List. . . . .	7-8
Warranty. . . . .	9

Follow the installation instructions in this manual carefully to ensure safe, reliable operation. All stated or implied manufacturer warranties are voided if this product is not installed in accordance with these instructions.

## MODULES

The module is a pre-assembled clutch-brake package complete with input and output shafts. These units are ready to be installed in all standard power transmission systems V-belts and pulleys, chain and sprockets, in-line couplings, timing belt drives, and gear trains.

### A. INSTALLING THE MODULE

1. Provide a mounting surface for the module that is rigid and flat with the following tolerances.

Module Sizes	Mounting Surface to be <u>Flat in One Plane Within:</u>
CBF22A	.004"
CBF50A	.010"

2. Connect the module into the drive system. The input shaft is identified on the unit. **Use care when connecting the modules!** Serious problems will occur if the power input is connected to the output shaft. Dimensions for the input and output shafts are shown on the illustration drawings, beginning on page 6.
3. Make the proper electrical connections between the module and a suitable DC power supply. Terminals are provided on the clutch and brake for this purpose. A wiring diagram showing the proper connections is furnished with each Boston Gear power supply.

## B. REPLACING WORN PARTS

The normal wearing components of the modules are the magnet, two armatures, and rotor. The mating components (magnet and armature or rotor and armature) generally wear at the same rate and should be replaced together.

1. Remove the cover from the module.  
 (Figure 1)

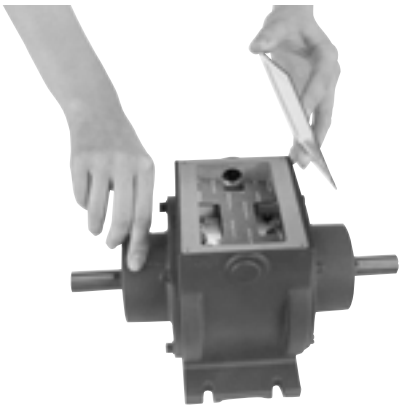

Figure 1

2. Disconnect the wires from the magnet terminals.
3. Remove the capscrews and washers from the output end bell and remove the end bell.  
 (Figure 2)
4. Remove and discard the worn armature(s).



Figure 2

5. Remove the used magnet and discard it.  
 Assemble the new magnet to the end bell.  
 (Figure 3)



Figure 3

6. Assemble a new armature on the armature hub with the segmented side toward the magnet.
7. Assemble the second armature in the opposite direction of the first.  
 (Figure 4)



Figure 4

8. Remove the retainer ring holding the rotor on the output shaft. Then remove the rotor and replace it with a new one. Replace the retainer ring. (Figure 5)

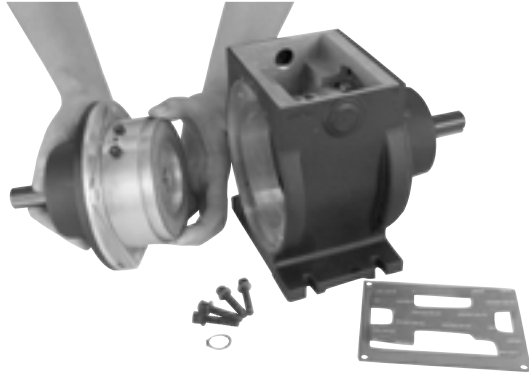

Figure 5

9. Reassemble the end bell in the module. Reassemble the capscrews and washers to the unit.
10. Set the autogaps by pressing each armature into contact with its mating component (either the magnet or rotor) and then releasing it. (Figure 6)

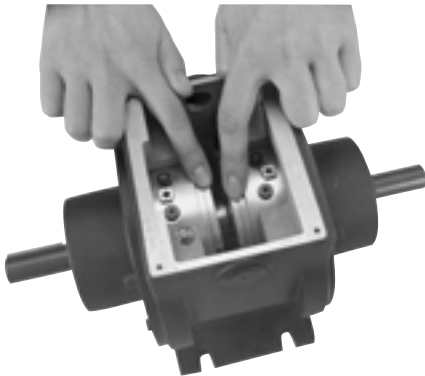

Figure 6

11. Reconnect the electrical wires to the magnet.
12. Reassemble the cover to the module.

## BURNISHING AND MAINTENANCE

### BURNISHING

Intimate metal to metal contact is essential between the armature and the metal rings (poles) of the magnet or rotor. Boston Gear clutches and brakes leave the factory with the friction material slightly undercut to assure good initial contact.

Normally, the desired wearing-in process occurs naturally as the surfaces slip upon engagement. The time for wear-in, which is necessary to obtain the ultimate torque of the unit, will vary depending on speed, load, or cycle duty.

If maximum torque is required immediately after installation, the unit should be burnished by slipping the friction surfaces together at reduced voltage. It is recommended that the burnishings be done right on the application, if at all possible.

Burnishing at high speed will result in a smoother wear-in pattern and reduce the time for burnishing. The voltage should be set at approximately 60% or 80% of the rated value.

The unit should be cycled on and off to allow sufficient time between slip cycles to prevent overheating.

When a Boston Gear brake or clutch is properly assembled and installed, no further servicing, lubrication, or maintenance should be required throughout the life of the module.

### MAINTENANCE

**WEAR PATTERN:** Wear grooves appear on the armature and magnet surfaces. This is a normal wear condition, and does not impair functioning of the unit. Normally, the magnet and armature, as a mating pair, will wear at the same rate. It is the usual recommendation that both components be replaced at the same time.

Remachining the face of a worn armature is not recommended. If a replacement armature is to be

used with a used magnet, it is necessary to remachine the worn magnet face. In refacing a magnet: (1) machine only enough material to clean up the complete face of the magnet; (2) hold the face within .005" of parallel with the mounting plate; and (3) undercut the molded facing material .001" - .003" below the metal poles.

**HEAT:** Excessive heat and high operating temperatures are causes of rapid wear. Units, therefore, should be ventilated as efficiently as possible, especially if the application requires fast, repetitive cycle operation.

**FOREIGN MATERIALS:** If units are used on machinery where fine, abrasive dust, chips or grit are dispelled into the atmosphere, shielding of the brake may be necessary if maximum life is to be obtained.

Where modules are used near gear boxes or transmissions requiring frequent lubrication, means should be provided to protect the friction surfaces from oil and grease to prevent serious loss of torque.

Oil and grease accidentally reaching the friction surfaces may be removed by wiping with a rag dampened with a suitable cleaner. In performing this operation, do not drench the friction material.

If the friction materials have been saturated with oil or grease, no amount of cleaning will be completely effective. Once such a unit has been placed back in service, heat will cause the oil to boil to the surface, resulting in further torque loss.

**TORQUE LOSS:** If a brake or clutch slips or loses torque completely, the initial check should be the input voltage to the magnet as follows:

Connect a DC voltmeter with a range of 0-100 or more directly across the magnet terminals. With the power on and the potentiometer turned up, a normal reading is 90 volts, although 85 to 95 is satisfactory. The reading should drop as the potentiometer control is adjusted counter-clockwise.

The above checks normally are sufficient. Further checks may be necessary, such as voltage, amperage and resistance. Refer to chart on following page for electrical readings on the clutch/brake you are measuring. Observe all safety procedures and test equipment manufacturers operating procedures. The voltage and amperage measurements are made with the power on and the control at full output.

Resistance measurements are made with power off and clutch / brake disconnected from control, measuring only the clutch coil or the brake magnet. Resistance measurements should be +/- 10% of values on chart.

If the above checks indicate that the proper voltage and current is being supplied to the clutch and brake, mechanical parts should be checked to assure that they are in good operating condition and properly installed.

**Electrical Data Coil Ratings**

CBF22A	Clutch	Brake
Voltage - DC	90	90
Resistance @ 20o C - Ohms	1087	1087
Current - Amperes	.083	.083
Watts	7.45	7.45
Coil Build up - milliseconds	154	154
Coil Decay - milliseconds	55	55

CBF50A	Clutch	Brake
Voltage - DC	90	90
Resistance @ 20o C - Ohms	206.1	251.1
Current - Amperes	.440	.360
Watts	39	32
Coil Build up - milliseconds	90	93
Coil Decay - milliseconds	40	30

Build-up time equals current to approximately 90% of steady state value and flux to 90%. Decay time equals current to approximately 10% of steady state value and flux to 10%. Approximately because current leads or lags flux by small amount.

## CBF22A Dimensional Drawing

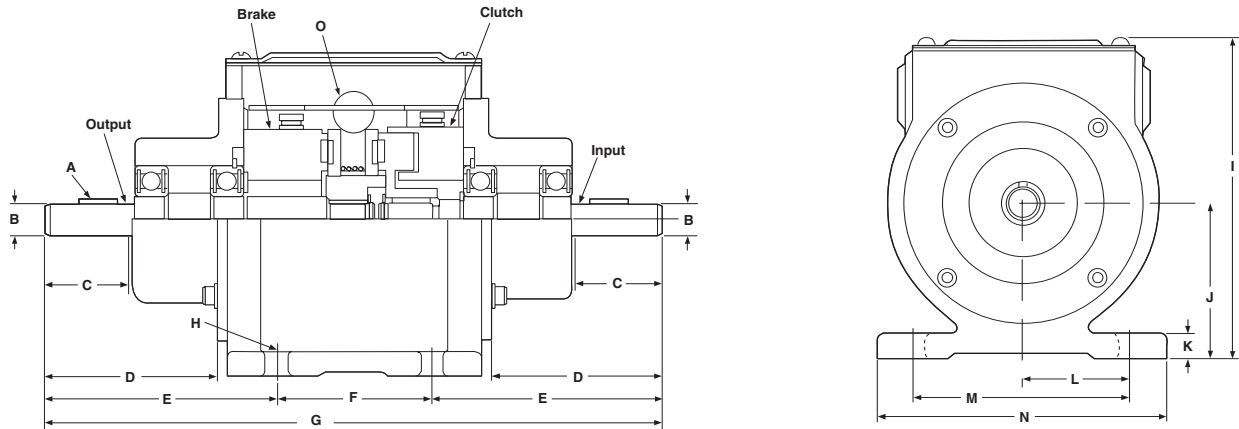

All dimensions are nominal, unless otherwise noted.

A	B	C Min.	D	E	F	G Max.	H
3/16 x 3/16 x 1-1/2 Dia.	<u>.7495</u> .7485	1.875	3.515	4.593	2.500	11.781	.312 Wide (4 slots)
I	J	K	L	M	N	O	
6.937	<u>3.474</u> 3.464	.500	2.578	5.156	6.00	1/2-14 NPT conduit x 2	
Voltage DC	Static Torque	Max. Speed	Total Weight	Inertia-WR <sup>2</sup> (lb-in <sup>2</sup> )			
90	22.5 lb. ft.	4,500 rpm	22 lbs.	Output	Input		
				2.566	2.222		

## CBF50A Dimensional Drawing

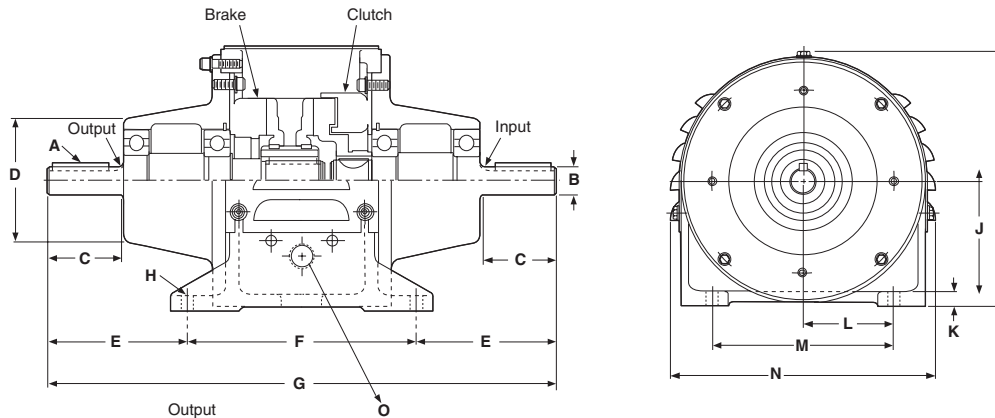

All dimensions are nominal, unless otherwise noted.

A	B	C Min.	D	E	F	G Max.	H
3/16 x 3/16 x 1-3/4 Dia.	<u>.8750</u> .8745	2.218	3.796	4.234	7.000	15.515	.406 (4 holes)
I	J	K	L	M	N	O	
8.218	<u>4.004</u> 3.992	.500	2.937	5.875	8.734	1/2-14 NPT conduit x 2	
Voltage DC	Static Torque (lb-ft)	Max. Speed	Total Weight	Inertia WR <sup>2</sup> (lb-ft <sup>2</sup> )			
90	Clutch 50 Brake 40	4,000 rpm	56 lbs.			.039 .063	

**CBF22A**

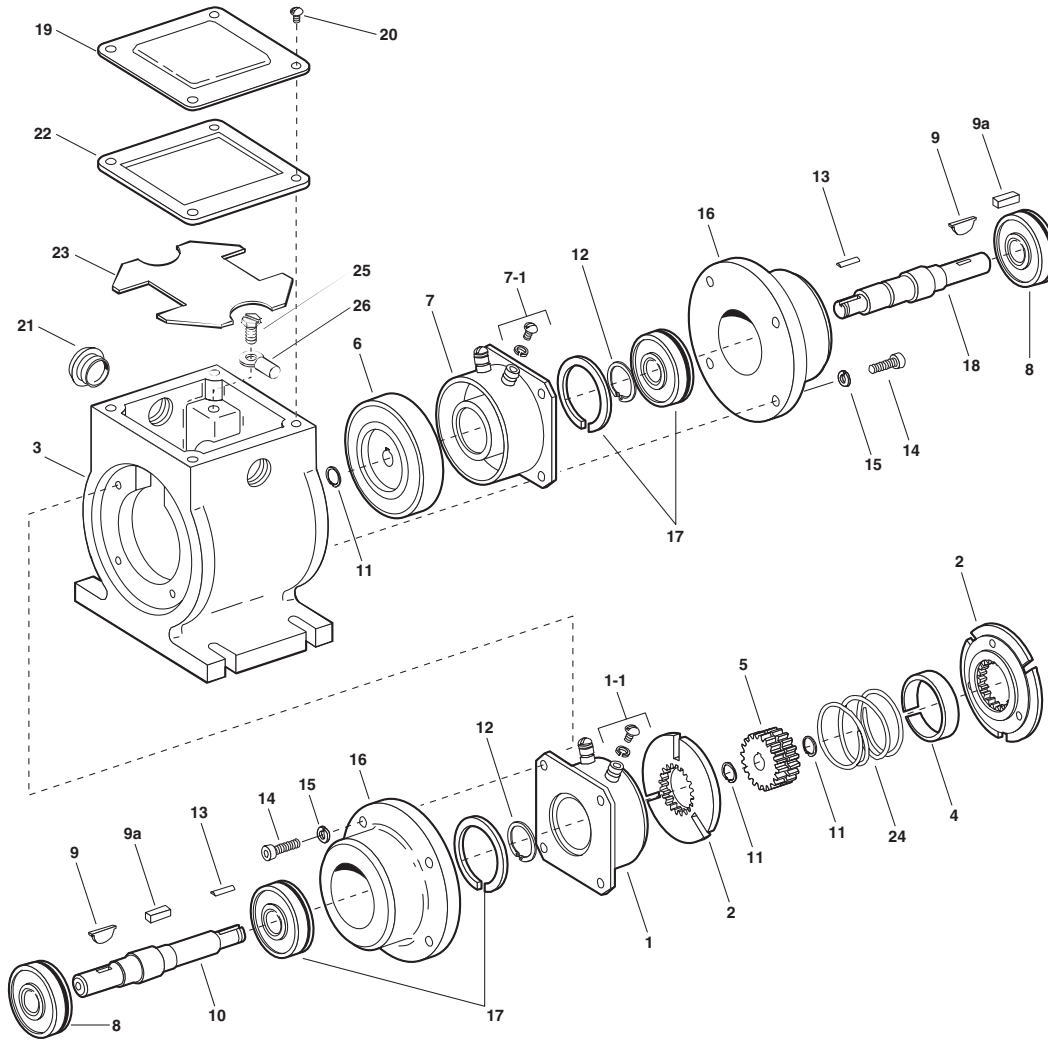

**Component Parts**

Item	Description	Part No.	Qty..
1	Magnet Assembly	5115-631-004	1
1-1	Terminal Accessory	5103-101-002	1
2	Armature Assembly with Autogap	5131-111-001	2
3	Housing	535-0083	1
5	Splined Armature Hub	540-2034	1
6	Rotor Assembly	5104-751-034	1
7	Field Assembly	5104-451-034	1
7-1	Terminal Accessory	5103-101-002	1
8	Ball Bearing	166-0116	2
9	Key	590-0016	2
10	Shaft, Brake	798-0131	1
11	Retainer Ring	748-0348	2
12	Retainer Ring	748-0022	2
13	Key	590-0087	2

Item	Description	Part No.	Qty.
14	Capscrew	797-1220	8
15	Lockwasher	950-0355	8
16	Bearing Housing	535-0084	2
17	Ball Bearing, with Retainer	166-0115	2
18	Shaft, Clutch	798-0132	1
19	Cover Plate	686-1019	1
20	Screw	797-0015	4
21	Dust Plug	680-0037	2
22	Gasket	495-0005	1
23	Insulator	572-0574	1
25	Ground Screw	797-1245	1
26	Terminal	900-0016	1

These units meet the standards of UL508 and are listed under guide card #NMTR, file #59164. These units are CSA certified under file #LR11543.

**HOW TO ORDER:** Order by catalog number of the module and indicate the part number you require.  
 Example: Part 166-0116 Ball Bearing for CBF22A.

## CBF50A

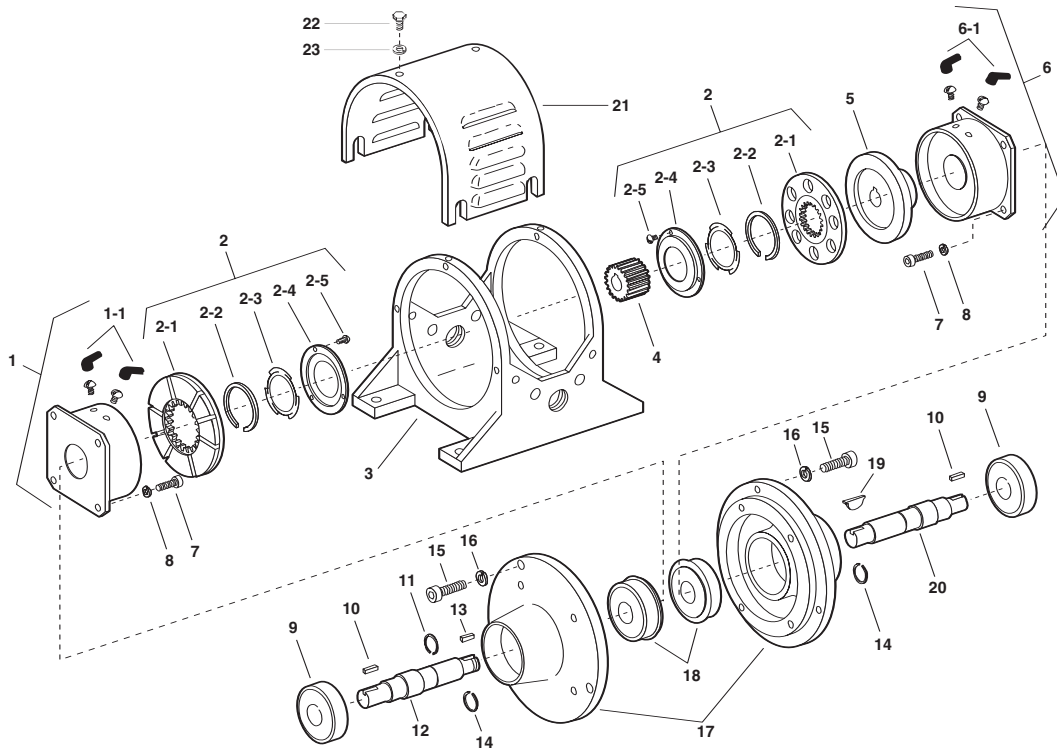

### Component Parts

Item	Description	Part No.	Qty.	Item	Description	Part No.	Qty.
1	Magnet Assembly	5300-631-011	1	9	Ball Bearing	166-0125	2
1-1	Terminal Accessory	5311-101-001	1	10	Key	590-0020	2
2	Armature Assembly	5230-111-002	2	11	Retainer Ring	748-0361	1
2-1	Armature	5230-111-001	2	12	Shaft, Brake	798-0022	1
2-2	Retainer Ring	748-0355	2	13	Key	590-0022	1
2-3	Spring	808-0412	2	14	Retainer Ring	748-0335	2
2-4	Retainer Plate	748-0364	2	15	Capscrew	797-0418	8
2-5	Screw	797-1430	12	16	Lockwasher	950-0107	8
3	Mounting Frame	174-0028	1	17	Endbell Housing	535-0010	2
4	Splined Hub	540-2035	1	18	Ball Bearing	166-0127	2
5	Rotor	5230-751-001	1	19	Key	590-0021	1
6	Field	5230-451-002	1	20	Shaft, Clutch	798-0023	1
6-1	Terminal Accessory	5311-101-001	1	21	Cover Drip Proof	287-0068	1
7	Capscrew	797-0416	8	22	Capscrew	797-1288	6
8	Lockwasher	950-0107	8	23	Lockwasher	950-0102	6
				*NS	Clamp Wire Speed Nut	263-0016	2
				*NS	Wire Assembly (Red)	5232-954-003	2
				*NS	Wire Assembly (Black)	5232-954-004	2
				*NS	Screws	797-1007	2
				*NS	Not Shown		

These units meet the standards of UL508 and are listed under guide card #NMTR, file #59164. These units are CSA certified under file #LR11543.

HOW TO ORDER: Order by catalog number and indicate the part number you require for the module.

## Warranty

Boston Gear warrants that products manufactured or sold by it shall be free from defects in material and workmanship. Any products which shall within two (2) years of delivery, be proved to the Company's satisfaction to have been defective at the time of delivery in these respects will be replaced or repaired by the Company at its option. Freight is the responsibility of the customer. The Company's liability under this limited warranty is limited to such replacement or repair and it shall not be held liable in any form of action for direct or consequential damages to property or person. The foregoing limited warranty is expressly made in lieu of all other warranties whatsoever, express, implied and statutory and including without limitation the implied warranties of merchantability and fitness.

No employee, agent, distributor, or other person is authorized to give additional warranties on behalf of Boston Gear, nor to assume for Boston Gear any other liability in connection with any of its products, except an officer of Boston Gear by a signed writing.



**Boston Gear, Inc.**  
14 Hayward Street • Quincy, MA 02171  
617-328-3300 • Fax: 617-479-6238  
[www.bostongear.com](http://www.bostongear.com)