

## Double C-Face Brakes

### DESCRIPTION

This brake is direct acting, electro-magnetically released and spring set. It uses rotating and stationary disc contact to supply positive braking action. It retains quick release and setting capabilities at all times.

Simplicity of design has reduced maintenance to an absolute minimum. As with any electro-mechanical equipment, however, periodic inspection and adjustment will assure optimum performance. As the friction discs wear, the magnet gap will increase. The magnet gap should be checked periodically and adjusted when necessary.



### INSTALLATION AND MAINTENANCE MANUAL

#### Important

Read this bulletin carefully before installing or operating this brake. Failure to comply with these instructions cancels all warranties since the safety of the unit may be endangered by improper installation or operating procedures.

**WARNING: Do not install or use these brakes in an explosive atmosphere.**

### Dimensions Figure 1.

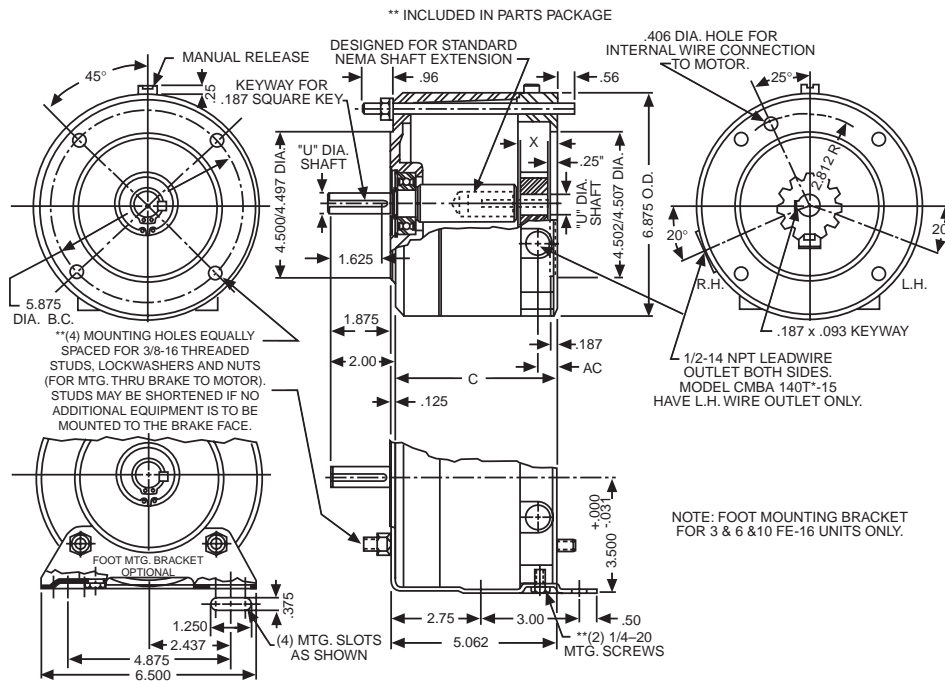

Catalog Number	Number of Rotating Discs	Torque Lb. Ft.	**Thermal Capacity HPS/MIN.	Inertia of Rotating Parts Lb. FT <sup>2</sup>	Dimensions				
					C	AC	U	1-Pc. Shaft X	2-Pc. Shaft X
CMBA56*-3	1	3	6	.006	4.937	.585	5/8	—	.88
CMBA56*-6	2	6	6	.010	4.937	.585	5/8	—	.88
CMBA56*-10	2	10	6	.010	4.937	.585	5/8	.81	—
CMBA140T*-6	2	6	6	.010	4.937	.585	7/8	—	.88
CMBA140T*-10	2	10	6	.010	4.937	.585	7/8	.81	—
CMBA140T*-15	3	15	6	.014	5.312	.873	7/8	1.19	—

\*\*Thermal capacity (HPS/MIN.) was determined under the following test conditions: a) Room temperature 72°F. b) Stopping time of one second or less. c) Brake mounted in a horizontal position. d) Equal on and off times. e) 1800 RPM. f) Coil energized with 110% of rated voltage. \* = voltage symbol.

MEX (55) 53 63 23 31  
 QRO (442) 1 95 72 60  
 MTY (81) 83 54 10 18  
 ventas@industrialmagza.com  
**MAGZA**  
 INDUSTRIAL  
 DIST. AUTORIZADO

# CMB SERIES



## DOUBLE C-FACE BRAKES

### WARNING:

Brake performance and features must be carefully matched to the requirements of the application.

Consideration must be given to torque requirements, especially where an overhauling condition exists, as well as thermal capacity, ambient temperature, atmospheric explosion hazards, type of enclosure and any other unusual conditions.

Improper selection and installation of a brake and/or lack of maintenance may cause brake failure which could result in damage to property and/or injury to personnel.

If injury to personnel could be caused by brake failure, additional means must be provided to insure safety of personnel.

### UNPACKING

When unpacking the brake, inspect it carefully for damage that may have occurred during transit.

### GENERAL SAFETY INFORMATION

**NOTE:** These brakes are not intended for accurate positioning applications. They are designed for applications that require rapid stopping and holding power, such as on conveyors, door openers, etc.

1. For applications with high inertia-type loads or rapid cycling, the thermal capacity of the brake must be considered.
2. Observe all local electrical and safety codes, as well as the National Electrical Code (NEC) and the Occupational Safety and Health Act (OSHA).
3. Brake motors and brake gearmotors must be securely and adequately grounded. This can be accomplished by wiring with a grounded metal-clad raceway system, by using a separate ground wire connected to the bare metal of the motor frame, or other suitable means. Refer to NEC Article 250 (Grounding) for additional information. All wiring should be done by a qualified electrician.
4. Always disconnect power before working on or near a brake motor, a brake gearmotor, or its connected load. If the power disconnect point is out of sight, lock it in the open position and tag it to prevent unexpected application of power.
5. When working on the brake, be sure the load is completely removed, secured or blocked to prevent injury or property damage.
6. Provide guarding for all moving parts.
7. Be careful when touching the exterior of an operating motor, gearmotor or brake. It may be hot enough to cause injury or to be painful. This condition is normal for modern motors, which operate at higher temperatures when running at rated load and voltage.
8. Protect all electrical lead wires and power cables against contact with sharp objects or moving parts.
9. Do not kink electrical lead wires and power cables, and never allow them to touch oil, grease, hot surfaces, or chemicals.

### INSTALLATION

**Caution:** To preserve pre-alignment of rotating discs for ease of installation, do not operate manual release or energize brake coil before installation.

**Note:** The brakes are designed for horizontal mounting. Modification is required for vertical mounting. Brakes suitable

for vertical mounting will have a suffix letter "U" (vertical up) or "D" (vertical down) in the catalog number.

Numbers in parentheses refer to parts illustrated in Figures 3 and 5.

### PLACING BRAKE ON MOTOR C FACE

#### For Models With One-Piece Shaft Designs:

1. Place 3/16" square key furnished into motor keyway. Key must extend to, and be flush with, end of motor shaft.
2. Place brake assembly onto the motor shaft, aligning the brake shaft keyway with key in the motor shaft. If the key wants to ride up at the end of the motor shaft keyway, push the key into the brake shaft with a screwdriver.

Do not use excessive force to seat the brake against the motor. If excessive force is required, the key may have to be filed.

Brake bracket (1) must be flush with the motor mounting face and adapter housing (7) must seat against the bracket (1).

Note: Arrow head on adapter housing should be in line with manual release knob (15); see Figure 5. The release should be located at the top.

3. Screw in four 3/8-16 threaded rods (28) or (32) through housing (7) and bracket (1) into motor C face (approx. 9/16" engagement or 9 turns).
4. If additional equipment is to be used, such as a gear reducer, install a key into the brake shaft extension. Slide equipment onto threaded rods, aligning key in the brake shaft with keyway in the equipment. Fasten with lockwashers (29) and nuts (30).
5. If no additional equipment is used, fasten brake assembly with items (29) and (30). The threaded rods may be cut off to suit the application.

#### For Models With Two-Piece Shaft Design:

1. Mount hub (22) over key on motor shaft 1/4" from the motor mounting face as shown in Fig. 1. Part number on hub to face away from motor. Use 3/16" square key furnished. Key must extend to, and be flush with, end of motor shaft. Tighten both setscrews in hub with 8 to 10 lbs. ft. torque.
2. Remove adapter housing (7). You may have to remove wrap cover (9) and tap lightly with a soft mallet in the openings in the side of the adapter housing. Place the brake assembly onto the motor C face, engaging hub splines into brake disc splines.

The release should be located at the top.

3. Screw in four 3/8-16 threaded rods (28) through bracket (1) into motor C face (approx. 9/16" engagement or 9 turns). Bring coil lead wires out of conduit hole before installing the adapter housing. Align adapter housing (7) with four threaded rods. NOTE: Arrow head on adapter housing should be in line with manual release knob (15); see Figure 5.

Slide adapter housing onto threaded rods, turning output shaft (8) so that the keyway in the brake shaft lines up with the key in the motor shaft. Make sure adapter housing seats against the bracket (1).

Tap adapter housing in place lightly. If excessive force is required, the key may have to be filed.

4. If additional equipment is to be used, such as a gear reducer, install a key into the brake shaft extension.

Slide equipment onto threaded rods, aligning key in the brake shaft with keyway in the additional equipment.

Fasten with lockwashers (29) and nuts (30).

- If no additional equipment is used, fasten adapter housing (7) with items (29) and (30). The threaded rods may be cut off to suit the application.

## CONNECTION OF COIL LEADS

After securing the brake to the motor, connect coil leads for proper voltage per wiring diagram (Figure 2 shows dual voltage coil). Incorrect connection can result in brake failure.

**Caution: The voltage supplied to the coil must match the voltage that the coils are connected for, or the coils will burn out.**

### Single voltage coil:

Connect brake coil leads to any two line leads (single or three phase) of same voltage and frequency as brake.

### Dual voltage coil:

Connect leads 2 and 4 to any two motor line leads (single or three phase) of same voltage as brake. Connect leads 1 and 3 as shown for voltage desired. Brake must be energized with motor.

## OPERATION

These brakes are spring set devices with an electrical (magnet) release. They contain a rotating friction disc which is driven by a hub mounted on the motor shaft. When energized, the magnet compresses the torque springs, removing the force pressing the stationary disc and friction disc together. This permits free rotation of the shaft.

**WARNING: Observe proper safety precautions in applications where a brake failure would allow the load to move in such a manner as to injure personnel. KEEP PERSONNEL AWAY FROM LOAD AREAS.**

If brake torque rating is higher than motor full-load torque rating, use brake rating rather than motor rating when selecting other drive components.

Take the following precautions when operating the brake:

- Do not operate the brake at higher than nominal static torque capacity.
- For applications with high inertia-type loads or rapid cycling, the thermal capacity of the brake must be considered.
- High start-stop rates may damage motor. Consult motor manufacturer if high cycling rates are expected.
- Be sure power supply conforms to electrical rating of brake.

## MANUAL RELEASE

The brake is equipped with a manual release. Turn the release knob (15) clockwise to stop position to release the brake. The brake will remain released until the release knob is turned counterclockwise (approx. 65°) or until the brake coil is energized, automatically resetting the brake.

## MAINTENANCE

**Caution: Before attempting to service or remove any components, make certain that the power is disconnected and that the load is completely removed, secured or blocked to prevent injury or property damage.**

## WIRING DIAGRAMS

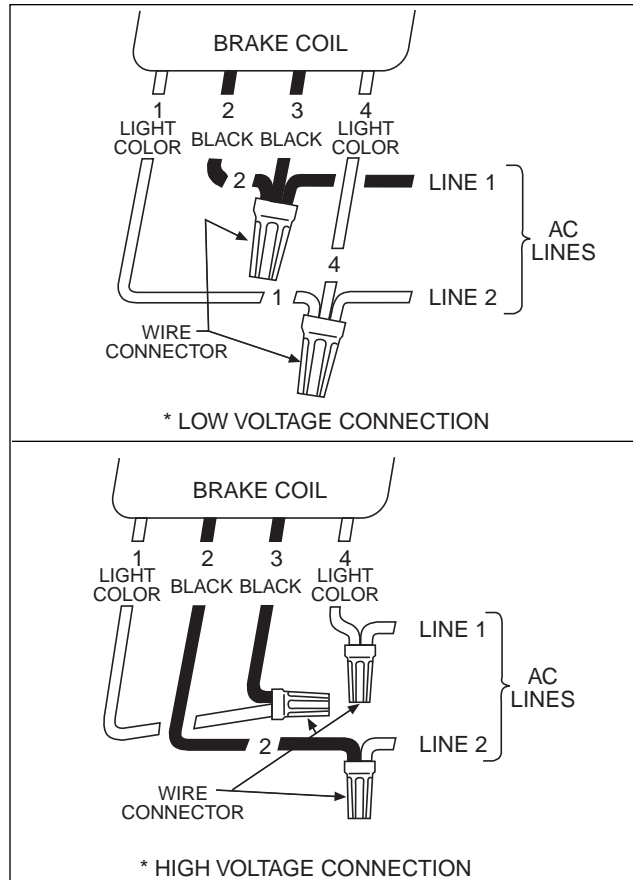

Figure 2.

## WEAR ADJUSTMENT

**Caution: Load to be removed or blocked. Brake may be inoperative during this procedure.**

Before air gap "A" reaches .100", adjustment is required. Any delay in adjusting the magnet air gap will result in eventual loss of torque.

Refer to Figure 3

- To adjust, remove cover (9) to expose adjusting screws (25M) and magnet air gap "A."
- Measure air gap "A" using 3/8" to 1/2" wide feeler gauge as shown in Figure 3.
- Turn two square head setscrews (25M) until air gap "A" measures:
  - .045/.050 for 1 disc model
  - .050/.055 for 2 disc models
  - .060/.065 for 3 disc models

Air gap should be the same on both sides.

## PIVOT STUD ADJUSTMENT

**Caution: Load to be removed or blocked. Brake will be inoperative during this procedure.**

Refer to Figures 3 and 5.

This adjustment is made at the factory and may be required when replacing the magnet assembly (25A) or the armature (25J).

MEX (55) 53 63 23 31  
 QRO (442) 1 95 72 60  
 ventas@industrialmagza.com

MTY (81) 83 54 10 18  
 MEX (55) 53 63 23 31  
 QRO (442) 1 95 72 60  
 DIST. AUTORIZADO



# CMB SERIES

## DOUBLE C-FACE BRAKES

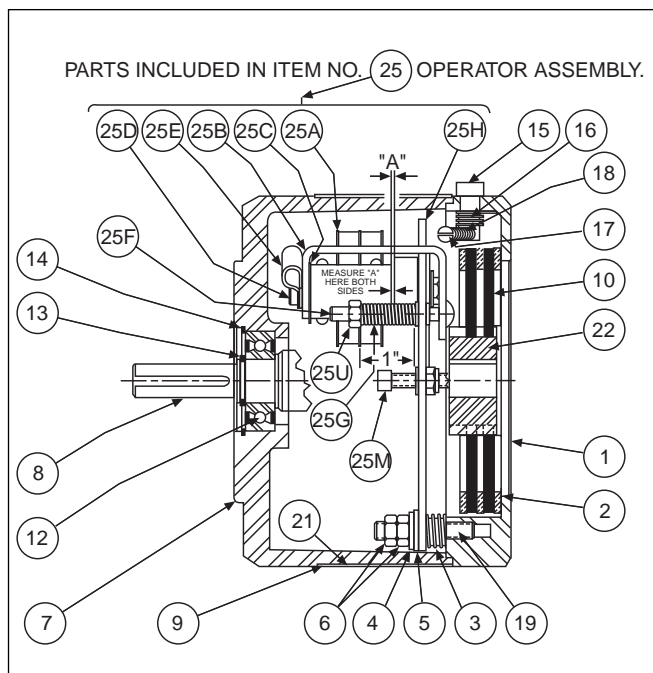

Figure 3.

The purpose is to regulate the height of the armature plate (25I) so that when the magnet (25A) is energized, the armature (25J) is parallel with it. This is required so that the magnet will be quiet.

**Note:** Adapter housing (7) must be removed to make this adjustment.

1. To adjust: Hold the nut (6) which is adjacent to washer (4) and loosen the other nut (6) and remove it from the stud.
2. Energize the magnet and turn remaining nut (6) counterclockwise slowly until the magnet becomes noisy. Turn magnet on and off several times until you find the position where the magnet first becomes quiet.

At this point turn nut (6) 1/3 turn (two flats) in a clockwise position. Hold nut in this position and turn magnet on and off to make sure the magnet does not become noisy.

3. Holding this nut in place, screw on other nut and tighten it against the nut you are holding. Tighten firmly.
4. Operate the manual release. If the release does not operate properly, see "Manual Release Adjustment" on page 4.

### MANUAL RELEASE ADJUSTMENT

**Caution: Load to be removed or blocked. Brake will be inoperative during this procedure.**

Refer to Figures 3 and 5.

The manual release (15) may require adjustment after replacing the operator assembly (25), magnet (25A), or armature (25J). It also may be required if adjustments are made on the pivot stud nuts (6).

The release is working properly if:

- a) you turn release knob (15) clockwise to stop and the brake is released.
- b) the release knob returns to its normal position automatically when power is applied to the magnet.

**Note:** Adapter housing (7) must be removed to make this adjustment.

1. To adjust: Set air gap "A" as described under "Wear Adjustment" on page 3.
2. If the brake does not release, turn adjusting screw (17) counterclockwise 1/4 turn and try again.
3. If the release knob (15) does not return to its normal position automatically, turn screw (17) clockwise 1/4 turn and try again.

**Note:** You may have to repeat Steps 2 or 3 to get the release to operate properly.

It is important that the release knob returns to its normal position automatically when power is applied to the magnet.

### TORQUE ADJUSTMENT

**Caution: Load to be removed or blocked. Brake may be inoperative during this procedure.**

The magnetic disc brake is factory set for rated static torque. The brake can be adjusted to reduce torque which increases stopping time. Do not attempt to adjust brake for higher torque, as this will cause premature coil burnout.

Refer to Figure 3.

1. To adjust, remove cover (9) to expose torque locknuts (25U), which are above torque springs (25G).
2. To increase stopping time and reduce torque, turn two locknuts (25U) counterclockwise, increasing spring length. Each full turn reduces torque 7% to 10% depending upon the model.

### FRICITION DISC REPLACEMENT

**Note: If the brake is suitable for vertical mounting observe the order and location of the disc spacing springs when disassembling the friction disks. Make sure that the disc spacing springs and friction disks in the same order when reassembled.**

**Caution: Load to be removed or blocked. Brake will be inoperative during this procedure.**

When total wear on a rotating friction disc (10) reaches 1/16", replace disc.

Refer to Figures 3 and 5.

#### Removing operator assembly

1. Disconnect power.
2. Remove any equipment mounted on the brake C face, such as a gear reducer, by removing nuts (30) and lockwashers (29). If no equipment is mounted on brake C face, remove nuts (30) and lockwashers (29).
3. Remove entire brake from motor C face. Remove retaining ring (13) or (37) from brake shaft (8/8A). Press shaft (8/8A) out of ball bearing (12) or (35) in adapter housing (7). A wheel puller using openings on side of adapter housing (7) may be used.
4. Remove operator assembly (25) by removing screws (11) and pivot stud (19). Item 19 has a hex socket in end of stud for removal.

**Note:** Do not loosen nuts (6) on pivot stud (19), or "Pivot Stud Adjustment" on page 3 to quiet the magnet will have to be made again.

MTY (81) 83 54 10 18  
ventas@industrialmagza.com

MEX (55) 53 63 23 31  
QRO (442) 1 95 72 60



### Replacing the friction disc

- Remove worn rotating discs (10) and stationary discs (2). Lay bracket (1) on a flat surface. Place a 5/16" thick spacer (1"x1" or 2"x2") on flat surface in the center of the brake. Place shaft (8A) in center of bracket with splined end down. Replace worn discs in the same order. Install stabilizer clip (23), if furnished, on rotating discs prior to installing.

### Re-assembly of operator assembly (25)

- Turn two screws (25M) counterclockwise five turns. Place operator assembly onto brake bracket (1) and install two screws (11). Replace compression spring (3), bushing (5), washer (6), and pivot stud (19) which has the two nuts (6) in place. Tighten firmly.
- Readjust magnet air gap "A" as described under "Wear Adjustment" on page 3.
- Check manual release operation before completing installation. Adjust per "Manual Release Adjustment" on page 4 if required.

### Completing installation

- Place adapter housing (7) over shaft (8A). Press bearing in adapter housing onto shaft by applying pressure to the inner race of the bearing only.

**Note:** The 5/16" thick spacer as described in Step 5 must still be in place. Replace retaining ring (13) or (37). Remove four threaded rods (28) from the motor and complete assembly as described under "Installation" (for models with one-piece shaft design).

### MAGNET ASSEMBLY REPLACEMENT

**Caution:** Load to be removed or blocked. Brake will be inoperative during this procedure.

Refer to Figures 3 and 5.

- Disconnect power supply.
- Remove adapter assembly as described under "Friction Disc Replacement" on page 4.
- Remove two capscrews (25D), wire clamps (25E), magnet assembly (25A) and shock mount (25C).
- Replace shock mount and magnet, feeding coil wires through hold in back of bracket (25B) as shown in Figure 4. Tighten mounting screws with 55 to 60 lb. in. torque.
- Set air gap "A" as described under "Wear Adjustment" on page 3.
- Energize coil. Magnet should be quiet; if not, refer to "Pivot Stud Adjustment" on page 3.
- Check manual release. If it does not operate properly, adjust as outlined under "Manual Release Adjustment" on page 4.
- Reassemble as described under "Friction Disc Replacement" and "Installation" on page 4.

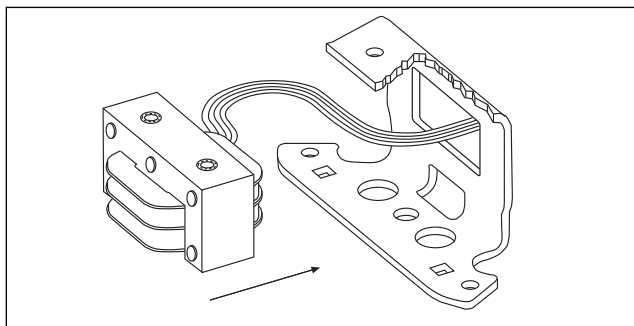

Figure 4.

### TROUBLESHOOTING CHART

Symptom	Possible Cause	Corrective Action
Brake does not release	<ol style="list-style-type: none"> <li>Broken or damaged parts</li> <li>Wrong voltage</li> <li>Burned out coil</li> <li>Incorrect wiring connections or broken wires</li> </ol>	<ol style="list-style-type: none"> <li>Replace</li> <li>Check for correct voltage. Voltage must correspond to that listed on brake nameplate. If the voltage is more than 10% below the nameplate voltage, the magnet may not pull in.</li> <li>Replace magnet assembly (25A).</li> <li>Find the connection or wiring fault. Correct or repair as required.</li> </ol>
Brake does not stop properly	<ol style="list-style-type: none"> <li>Broken or damaged parts</li> <li>Worn friction disc</li> <li>Hub positioned incorrectly (models with two-piece shaft and hub only)</li> <li>Brake is manually released</li> </ol>	<ol style="list-style-type: none"> <li>Replace</li> <li>Replace disc if worn to 1/16" thickness. If disc replacement is not required, adjust air gap. (Refer to "Wear Adjustment" section.)</li> <li>Relocate hub (22) and key (33), if required. (Refer to "Installation" section.)</li> <li>Determine if manual release is in normal position.</li> </ol>
Brake chatters or hums	<ol style="list-style-type: none"> <li>Dirty magnet faces</li> <li>Magnet faces are not parallel in closed position</li> <li>Loose or broken shading coil</li> <li>Wrong voltage supply</li> </ol>	<ol style="list-style-type: none"> <li>To remove dirt, insert a clean sheet of paper between faces and energize brake. Move paper around between faces to dislodge dirt, then remove paper.</li> <li>See "Pivot Stud Adjustment" section.</li> <li>Replace magnet assembly (25A)</li> <li>Check for low voltage</li> </ol>
Manual release does not work	<ol style="list-style-type: none"> <li>Broken or damaged parts</li> <li>Improper setting</li> </ol>	<ol style="list-style-type: none"> <li>Replace</li> <li>See "Manual Release Adjustment" section.</li> </ol>

# CMB SERIES

## DOUBLE C-FACE BRAKES

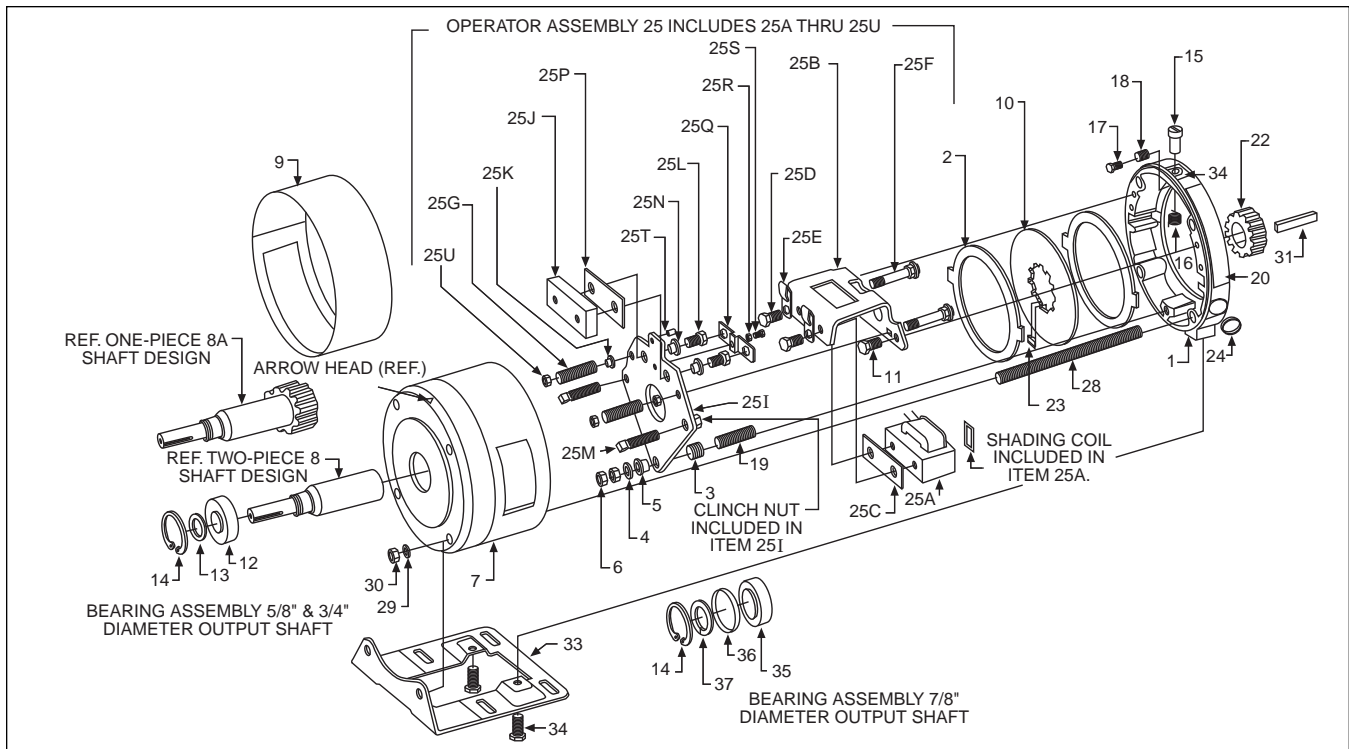

Figure 5.

### REPLACEMENT PARTS LIST

Item No.	Description	Part Number	Qty.	Item No.	Description	Part Number	Qty.
1	Bracket 1 & 2 disc	L060252002	1	25G	Torque spring (silver) 3 & 6 lb. ft. Torque spring (bronze) 10 & 15 lb.	G060792-001	2
2	Stationary disc	67562	*				2
3	Compression spring	G060821-001	1	25H	Armature plate assembly: Includes "I" through "T" (not shown as an assembly)	H060541-**	1
4	Plain brass washer	W004003-024	1	25I	Armature plate	H060545-003	1
5	Nylon bushing	G060820-001	1	25J	Armature lamination assembly	G060788-001	1
6	Hex nut 5/16-18 thread	W003002-002E	2	25K	Nyliner bushing	W013005-001	2
7	Adapter housing	L060251-001	1	25L	Hex. Hd. capscrew 1/4-20x5/8 Lg.	W001007-002E	2
8	Two piece shaft	**	1	25M	Wear adjustment screw sq. hd. 1/4-20x1-1/2" Lg.	W002003-001	2
8A	One piece shaft hub	**	1	25N	Armature spacer	G060798-002	2
9	Wrap-around cover	K060462-001	1	25P	Armature shock mount	G060808-003	1
10	Splined rotating friction disc	67563	*	25Q	Locking plate	G060812-001	1
11	Hex. Hd. capscrew 1/4-20 x 1/2 Lg.	W001008-001E	2	25R	Split spring lockwasher #8	W004006-003	1
12	Double seal ball bearing, 5/8 output shaft	W009001-001	1	25S	Soc. Hd. capscrew #8-32x1/4" Lg.	W001013-201	1
13	Truarc retaining ring, 5/8 output shaft	W006007-001	1	25T	Roll pin 5/32" dia. x3/8" Lg.	W005003-098	1
14	Truarc retaining ring, all models	W006002-001	1	25U	Locknut 1/4-20	W003013-001	2
15	Release knob	G060785-001	1	26	Hardware bag includes 28 through 31	H060237-082	1
16	Release return spring	G060797-001	1	28	Mounting stud, 3/8-16x6-7/16 Lg.	W012001-001	4
17	Release adjustment screw	W001002-056C	1	29	3/8 split spring lockwasher	W004006-008	4
18	Release adjustment lock spring	G060795-001	1	30	Hex nut 3/8-16	W003002-003	4
19	Pivot stud	W002005-303A	1	31	Key 3/16 sq. x 1-13/16 Lg.	W007001-017	1
20	Nameplate	K060474-001	1	32	Key attaching label (not shown)	G060648-001	1
22	Splined Hub for use with Item 8	**	1	33	Foot mtg. bracket	67561	1
23	Stabilizer clip, rotating friction disc	H060466-001	*	34	Hex. Hd. Capscrew 1/4-20x1/2 Lg.	W001008-001E	2
24	Wire outlet cap plug	W008003-001	1	35	Double seal ball bearing, 7/8 output shaft	W009001-009	1
25	Operator assembly: includes "A" through "U" (not shown as an assembly)	K060463-**	1	36	Bearing spacer	G060531-001	1
25A	Magnet assembly	**	1	37	Truarc retaining ring, 7/8 output shaft	W006007-002	1
25B	Magnet mounting bracket	H060544-001	1				
25C	Magnet shock mount	G060813-001	1				
25D	Hex. Hd. capscrew 1/4-20x5/8 Lg. Grade 5	W001007-002E	2				
25E	Cable clamp	W021003-001	2				
25F	Carriage bolts 1/4-20	G060803-001	2				

\*The models with 3 Lb. Ft. Torque have (1) rotating disc, (2) stationary discs and (1) stabilizer clip. The models with 6 Lb. Ft. Torque have (2) rotating discs, 3 stationary discs and (2) stabilizer clips.

\*\*Part number is determined by one or more of the following: model number, voltage, motor shaft diameter and keyway size.