

Boston Gear[®]

Ratiotrol[®]

DC Motor Speed Control

Installation and Operation

Doc. No. 60007

*DCX plus™ Series II
Enclosed Models 1/12 - 1 HP*



Table of Contents

Section I	General Information	
	Description	3
	Ratings	3
	Operating Conditions	3
	Performance Characteristics	3
	Safety Warnings	3-4
Section II	Installation	
	Mounting	4
	Reversing	4
	DCX Plus Connections	5
	Wiring Instructions	4
	Initial Start Up	5
	Tachometer Feedback	5
Section III	Calibration Procedure	
	Safety Precautions	6
	Procedure	6-7
Section IV	Dimensions	7

LIMITED WARRANTY

The Company warrants that products manufactured or sold by it shall be free from defects in material and workmanship. Any products which shall within two (2) years of delivery, be proved to the Company's satisfaction to have been defective at the time of delivery in these respects will be replaced or repaired by the Company at its option. Freight is the responsibility of the customer. The Company's liable in any form or action for direct or consequential damages to property or person. THE FOREGOING WARRANTY IS EXPRESSLY MADE IN LIEU OF ALL OTHER WARRANTIES WHATSOEVER, EXPRESS IMPLIED AND STATUTORY AND INCLUDING WITHOUT LIMITATION THE IMPLIED WARRANTIES OF MERCHANTABILITY AND FITNESS.

No employee, agent, distributor, or other person is authorized to give additional warranties on behalf of Boston Gear, nor to assume for Boston Gear any other liability in connection with any of its products, except an officer of Boston Gear by a signed writing.

Please read and follow installation instructions carefully before operating the unit.

Section I

General Information

Description

Ratiotrol DCX controllers statically convert single-phase AC line power to regulated DC for adjustable speed armature control of shunt-wound and permanent-magnet DC motors.

Ratings

1. Service Factor1.0
2. DutyContinuous
3. EnvironmentIndustrial
4. Overload Capacity150% for 1 minute

Operating Conditions

1. Line Voltage115/230 VAC ± 10%
2. Line Frequency50/60 Hz ± 2 Hz
3. Ambient Temperature
.....0°C to 40°C (32°F to 104°F)
4. Altitude3300 feet
.....(1000 meters) maximum
5. Relative Humidity95% noncondensing
.....maximum
6. DC Tachometer Voltage35, 50 or 100
.....VDC/1000 RPM*
*(Modifiable for 7 VDC/1000 RPM)

Enclosure

The DCX plus controllers are available in three mounting configurations NEMA 1, NEMA 12 and panel front. The enclosure forms an integral heat sink with the power control devices electrically isolated from the enclosure. Complete controller is attached to the front cover, which can be removed from the enclosure by removing four screws. The panel front mounting can be installed in your present control panel.

Performance Characteristics

1. Controlled Speed Range 0 to motor base speed

2. Speed Regulation Regulation percentages shown in Table 2 are of motor base speed under steady-state conditions
3. Efficiency (at maximum speed)
 - a. Controller 99%
 - b. Controller with motor 85%

Adjustments

1. Accel/Decel0.8 -10 seconds
2. Maximum Speed (% of full speed)60 -100%
3. Current Limit (% full load torque)0 -150%
4. Minimum Speed (% of full speed)0 -40%
5. IR Compensation (% of rated load)0 -100%

Regulation Method	Variable				
	Load Change 95%	Line Voltage +/- 10%	Field Heating Cold/Normal	Temp. +/- 10%	Speed Range
Standard Voltage Feedback with IR Compensation	2%	+/- 1%	5-12%	+/- 2%	30:1
Tach Feedback (Uni-directional models only)	+/-1%	0.2%	+/- 2%	100:1	

TABLE 2 — Speed Regulation Characteristics

Safety Warnings

- Controller is not isolated from earth ground. Thus the printed circuit board and its components are at AC line potential and could cause serious injury.
- Follow all local electrical and safety codes, as well as National Electrical Code (NEC) and when applicable, the Occupational Safety and Health Act (OSHA). This

TABLE 1 - RATINGS

Rated HP	Full Load Torque LB. IN.	AC Input, Single Phase, 50/60 Hz (Full Load)			DC Output (Full Load)			
		Line Amps		KVA	Motor Arm. Amps		Motor Field Amps	
		DCX Plus			90 VDC	180 VDC	100 VDC	200 VDC
		115 VAC	230 VAC					
1/12	3	2.0		0.30	0.9		1.0	
1/6	6	3.9		0.48	2.0		1.0	
1/4	9	5.0		0.58	2.8		1.0	
1/3	12	6.0		0.71	3.5		1.0	
1/2	18	8.7	4.8	1.0	5.4	2.7	1.0	1.0
3/4	27		5.9	1.4		3.8	1.0	1.0
1	36		8.8	2.0		5.5	1.0	1.0

device should be installed, adapted and serviced by qualified electrical maintenance personnel familiar with the construction and operation of the equipment and the hazards involved.

- Motor and Controller must be securely and adequately grounded.
- Always disconnect power source before working on or near controller and motor or their lead wires.
- Make sure the power source conforms to the requirement of your equipment.
- Do not operate controller near high capacitive discharge electrical equipment (i.e. electrical welders).
- When cleaning electrical or electronic equipment, always use an approved cleaning agent such as dry cleaning solvent.
- Do not operate controller in an explosive atmosphere.
- Use insulated tools (non-metallic) when making running adjustments. Be careful not to touch any components except the adjusting trim pots.
- SCR CONTROLLERS ARE NOT FAIL SAFE. IF AN SCR SHORTS, CONTROL BOARD FAILS OR GROUND FAULT OCCURS, MOTOR MAY RUN AT FULL SPEED.

SECTION II INSTALLATION INSTRUCTIONS

Mounting:

Do not locate DCX plus Series Controller where moisture, oil solvents or dust can affect controller operation or damage its components. Never mount the controller immediately beside or above heat-generating equipment, or directly below water or steam pipes. See page 15 for mounting dimensions.

CAUTION: DO NOT MOUNT CONTROLLER WHERE AMBIENT TEMPERATURE IS OUTSIDE THE RANGE OF 0° C (32° F) TO +40° C (104° F)

Select enclosure rating, NEMA 1 or NEMA 12, to conform with ambient conditions.

Shock and excessive vibration are detrimental to controller performance and life. Vibration can cause general deterioration of connections and component damage. Therefore, shock mount the controller if it is subjected to excessive vibration.

Reversing

Reversing models are supplied with a forward/stop/reverse switch in addition to the standard on/off switch. This switch provides a hesitation in the stop mode. **THE MOTOR MUST COME TO A COMPLETE STOP PRIOR TO CHANGING ROTATION.**

Wiring Instructions

Refer to the data label on the controller to be sure the input voltage and frequency to the controller comply with its rating. Follow all local electrical and safety codes, as well as National Electrical Code (NEC) and when applicable, the Occupational Safety and Health Act (OSHA). This device should be installed, adapted and serviced by qualified electrical maintenance personnel familiar with the construction and operation of the equipment and the hazards involved.

1. Place the controller on a feeder line separate from that supplying large inductive loads.
2. If the input power to the controller comes directly from a transformer, always switch power on and off to the controller from the transformer secondary. Turning power on and off in the transformer primary can cause controller damage.
3. Never use power factor correction capacitors on the input line to the controller. These capacitors can cause controller damage.
4. The wire size of the AC input power and motor wiring can be determined from Table 1.
5. All external wiring for low voltage signal sources, such as potentiometers, tachometer generators and transducers should be run in separate conduit from all other wiring. Use twisted cable. Maintain the separation of power and signal wires by 2" and cross these wires only at 90° angles. Minimum required wire size is 18 gauge, but check with your local electrical and safety codes, as well as National Electric Code (NEC).
6. The front panel on the controller can mount to the box housing with two screws to allow easy access for wiring and adjustments.
7. Figure 1 Page 7 shows the connections for AC input power and the DC motor leads to the controller.
8. A grounding wire with a quick connector attached is provided with the controller. If the connector is not to be used, remove the connector and strip the wire as required.
9. Refer to page 10 for tachometer feedback instructions.
10. To protect the controller, an AC line fuse, Bussmann KTK 10 or Gould ATM 10 has been installed in the fuse holder provided on the printed circuit board inside the controller. When using 115 VAC, the "HOT line" should connect to the "L1" (TB1) Terminal and the neutral line should connect to the "L2" (TB1) Terminal.
11. Separate motor overload protection must be provided by the user.
12. Motor Speed Potentiometer can be removed from the cover and be remotely mounted.
13. Make sure the controller and motor housings are securely and adequately grounded.

DCX plus Connection Drawing

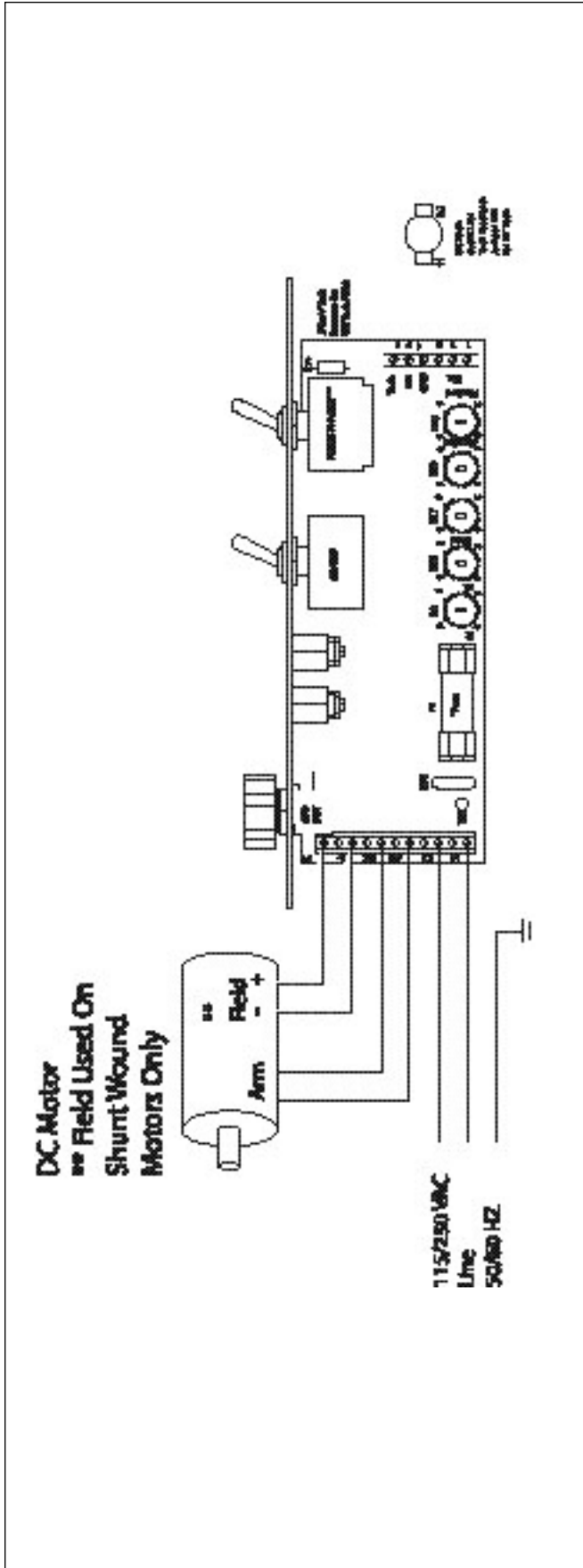

Initial Startup

1. Make sure AC power is off.
2. Wire the motor and controller per Figure 1. Be sure connections are tight.
3. Adjust the controller calibration trim potentiometers per Table #3. Location of trim potentiometers are shown in Figure 1 Page 7. Use the nearest horsepower rating and proper line voltage as a guide to setting the trim potentiometers.
4. Set the controller's run speed potentiometer full counterclockwise.
5. Apply AC line power to the controller and with load on the motor, initiate run mode. Next, turn the run speed potentiometer clock-wise while observing the motor rotation. If motor rotates in the wrong direction, remove AC power to the controller. Then reverse the DC motor armature connections to the controller.
6. Apply AC line power to the controller and initiate the run mode. Check for satisfactory operation through-out the full speed range.
7. If acceleration is either too fast or too slow, or if the motor is surging in speed, shows instability or has excessive speed, go to the controller trim potentiometer calibration procedure on page 12. The potentiometer adjustments shown in Table #3 were established on Boston Gear permanent magnet motors, other motors may require a slightly different setting for the IR comp potentiometer.

Tachometer Feedback

(for uni-directional models only)

DCX plus controllers are supplied with a tachometer feedback circuit, for use with a 35, 50 or 100 VDC/1000 RPM signal. If a signal of 7 VDC/1000 RPM is to be used modify control per instructions below. Refer to Figure 1 on Page 7.

1. Remove W2 jumper on the printed circuit board.
2. Connect the negative tach signal lead to the "Com" (TB2-4) terminal and connect the positive tach signal lead to the "Tach" (TB2-6) terminal. Use twisted cable. Maintain the separation of power and signal wires by 2 inches and cross these wires only at 90° angles.
3. Turn maximum speed (MAX SPD) potentiometer on controller full counterclockwise. Apply AC power and initiate run mode. Turn the run speed potentiometer full clockwise, then turn the maximum speed (MAX SPD) trim potentiometer clockwise until you reach the motors base speed.

When using a 7 VDC/1000 RPM tach generator: Resistor R14 on the printer circuit board must be either jumpered or shorted.

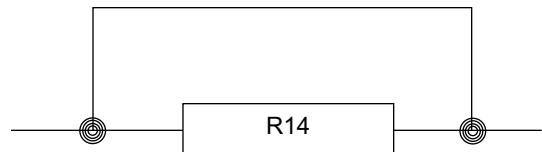

Figure 2

**TABLE 3—
 CONTROLLER ADJUSTMENT CHART**

MAX SPEED	ACCEL DECEL	IR COMP	CURRENT LIMIT	MIN SPEED	LINE VOLTAGE	H.P.
					115	1/12
					115	1/6
					115	1/4
					115	1/3
					115	1/2
					230	1/2
					230	3/4
					230	1

(Suggested initial start-up settings)

All of the potentiometer trim POTS, when turned full counter clockwise, should have the arrow on the white plastic guide (which sits on top of the POT) should be pointing to the zero mark on the board. If this is not the case, remove the plastic guide and repeat it with the arrow pointing to zero.

**SECTION III
 Calibration Procedure**

Safety Precautions

This device should be installed, adapted and serviced by qualified electrical maintenance personnel familiar with the construction and operation of the equipment and the hazards involved.

WARNING: CONTROLLER IS NOT ISOLATED FROM EARTH GROUND. THUS THE PRINTED CIRCUIT BOARD AND ITS COMPONENTS ARE AT A POTENTIAL OF 115 OR 230 VAC ABOVE GROUND AND COULD CAUSE SERIOUS INJURY. PLEASE RE-READ SAFETY WARNINGS ON PAGE 5.

CAUTION: USE A NON-METALLIC SCREWDRIVER WHEN ADJUSTING THE CONTROLLER TRIM POTENTIOMETERS TO AVOID THE METAL SCREWDRIVER BLADE MAKING CONTACT WITH LIVE CIRCUITRY AND CAUSING SERIOUS INJURY.

CAUTION: DO NOT TEST OR CHECK CIRCUIT CONTINUITY BY SHORTING TERMINALS. THIS COULD CAUSE DISASTROUS FAILURE AND VOID WARRANTY.

Equipment

The following equipment is required to calibrate DCX plus Controller.

- AMMETER: 0-10 AMPS D.C.
- TACHOMETER: To measure RPM.

Procedure

Connect motor and AC line power per wiring instructions on Page 9:

1. Remove AC line power from the controller
2. Set run speed potentiometer full counterclockwise
3. Set maximum speed (MAX SPD) trim potentiometer full counterclockwise
4. Set minimum speed (MIN SPD) trim potentiometer full counterclockwise
5. Set IR comp (IR) trim potentiometer full counterclockwise
6. Set current limit (CL) trim potentiometer full clockwise
7. Connect DC ammeter (0-10 amps) in series with an armature lead on the motor (see Figure 3)

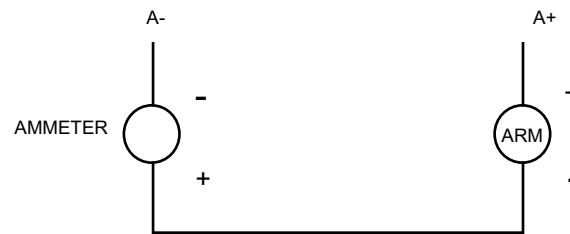

Figure 3

8. Accel/Decel – Set A/D (ACCEL) trim potentiometer on DCX plus controller for the desired time. This potentiometer allows adjustable linear acceleration and deceleration with one potentiometer. The potentiometer can be adjusted from .8 to 10 seconds. See Figure 4.

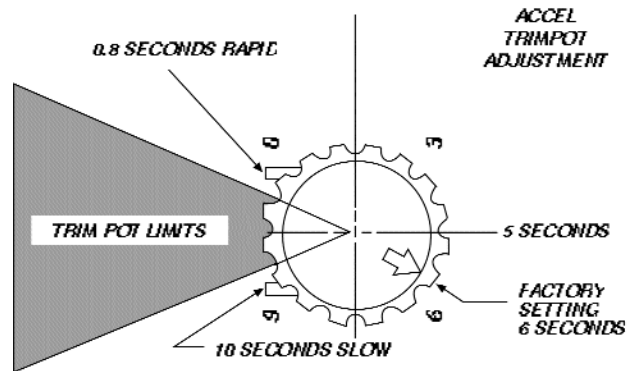

Figure 4

9. Remove the load from the motor. Apply AC line power to the controller and initiate the run mode.
10. Set run speed potentiometer full clockwise. Adjust maximum speed (MAX SPD) trim potentiometer until the tachometer reads motor nameplate speed.
11. Set run speed potentiometer full counterclockwise. Adjust minimum speed (MIN SPD) trim potentiometer clockwise until motor begins to rotate, then slowly adjust it counterclockwise until the motor stops.
12. Repeat steps 10 and 11 until both maximum and

minimum speeds are at their desired level.

13. IR compensation (load regulation) – Adjust run speed potentiometer so that the motor is running at 1000 RPM. Apply full load to the motor and adjust IR Comp (IR) trim potentiometer clockwise until the motor returns to 1000 RPM. If motor speed becomes unstable, turn IR Comp (IR) trim potentiometer counterclockwise until the instability goes away. The maximum speed (MAX SPD) trim potentiometer may now have to be readjusted (See Step 10).
14. Current Limit – Set run speed potentiometer full clockwise. Set current limit (CL) trim potentiometer full counterclockwise and the motor should stall. Remove power from control. Lock the motor shaft. Reapply power and adjust the current limit (CL) trim potentiometer clockwise until the armature current is 150% of the motor nameplate current.
15. Set run speed potentiometer full counterclockwise. Initiate a stop mode and then remove AC line power.
16. Unlock the motor shaft. The calibration is now complete.

Dimensions

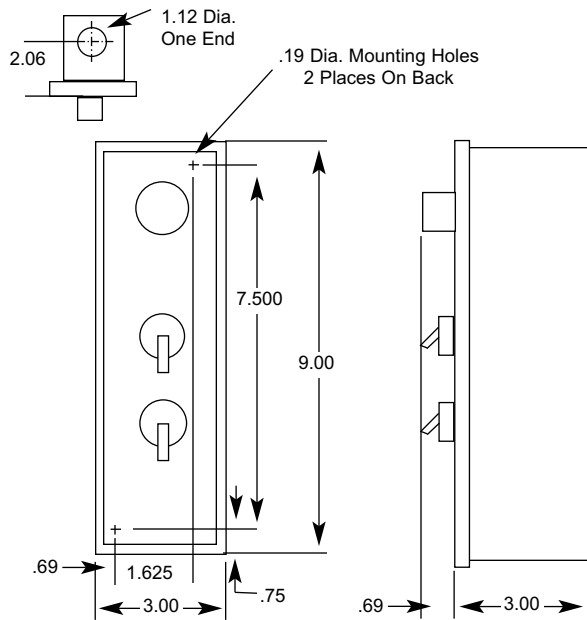

DCX202E and DCX202ER Dimensions
Figure 5

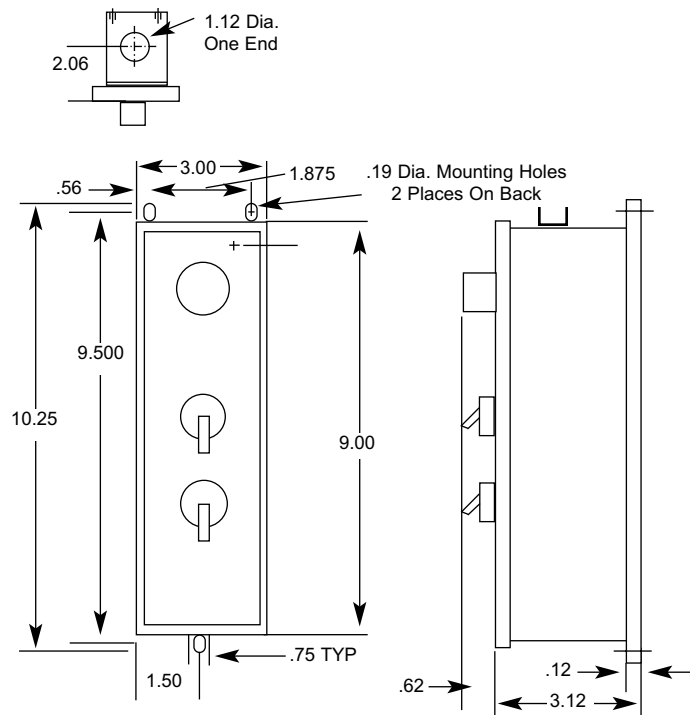

DCX202EN12 and DCX202ERN12 Dimensions
Figure 6

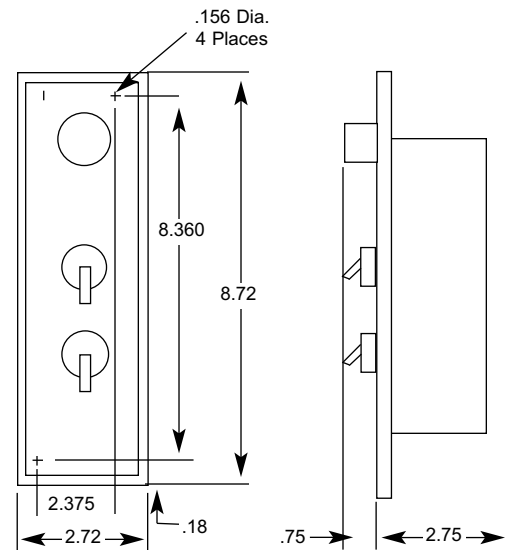

DCX202EP and DCX202ERP Dimensions
Figure 7

Panel Front Cutout

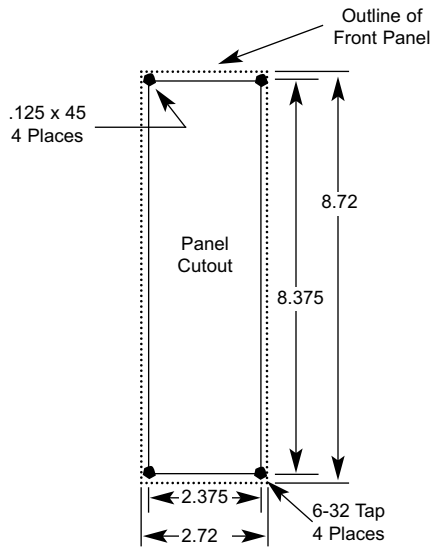

DCX202EP and DCX202ERP Panel Cutout Dimensions
Figure 8



Boston Gear
14 Hayward Street
Quincy, MA 02171
tel 617 328 3300
fax 617 479 6238
www.bostongear.com