



502-AC-SM-001-02

INSTALLATION AND SERVICE MANUAL

FOR

SERVO DRIVEN

UniMount GEARBOX

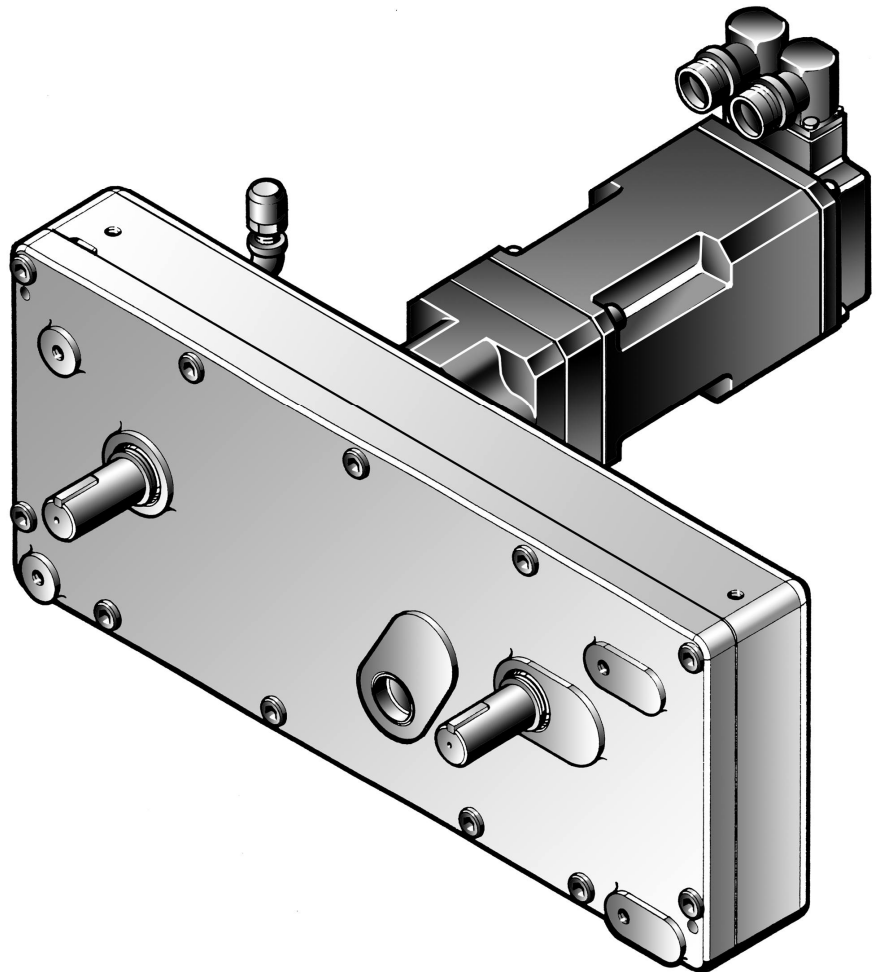

FORCE CONTROL INDUSTRIES, INC.

WARNING - Read this manual before any installation, maintenance or operation.

MANUFACTURERS OF MECHANICAL AND ELECTRICAL POWER TRANSMISSION EQUIPMENT



INDUSTRIAL MAGZA®
DIST. AUTORIZADO

MEX (55) 53 63 23 31
QRO (442) 1 95 72 60

MTY (81) 83 54 10 18
ventas@industrialmagza.com

Limited Warranty

Force Control Industries, Inc. ("Force Control") warrants its products to be free from defects in material and workmanship under normal and proper use for a period of one year from the date of shipment. Any products purchased from Force Control that upon inspection at Force Control's factory prove to be defective as a result of normal use during the one year period will be repaired or replaced (at Force Controls' option) without any charge for parts or labor. This limited warranty shall be void in regard to (1) any product or part thereof which has been altered or repaired by a buyer without Force Control's previous written consent or (2) any product or part thereof that has been subjected to unusual electrical, physical or mechanical stress, or upon which the original identification marks have been removed or altered. Transportation charges for shipping any product or part thereof that the buyer claims is covered by this limited warranty shall be paid by the buyer. If Force Control determines that any product or part thereof should be repaired or replaced under the terms of this limited warranty it will pay for shipping the repaired or replaced product or part thereof back to the buyer. EXCEPT FOR THE EXPRESS WARRANTY SET OUT ABOVE, FORCE CONTROL DOES NOT GRANT ANY WARRANTIES EITHER EXPRESSED OR IMPLIED, INCLUDING IMPLIED WARRANTIES OF MERCHANTABILITY OR FITNESS FOR USE. The warranty obligation set forth above is in lieu of all obligations or liabilities of Force Control for any damages. Force Control specifically shall not be liable for any costs incurred by the buyer in disconnecting or re-installing any product or part thereof repaired or replace under the limited warranty set out above. FORCE CONTROL EXPRESSLY EXCLUDES ALL LIABILITY FOR ANY INDIRECT OR CONSEQUENTIAL DAMAGES THE BUYER MAY SUSTAIN IN CONNECTION WITH THE DELIVERY, USE, OR PERFORMANCE OF FORCE CONTROL PRODUCTS. Under no circumstances shall any liability for which Force Control is held responsible exceed the selling price to the buyer of the Force Control products that are proven to be defective. This limited warranty may be modified only in writing signed by a duly authorized officer of the company. This limited warranty applies exclusively to Force Control products; warranties for motors and gear reducers and other component parts may be provided by their respective manufactures. Any legal action for breach of any Force Control warranty must be commenced within one year of the date on which the breach is or should have been discovered.

A Return Goods Authorization (RGA) number must be obtained from the factory and clearly marked on the outside of the package before any equipment will be accepted for warranty work. Force Control will pay the shipping costs of returning the owner parts that are covered by warranty.

Force Control believes that the information in this document is accurate. The document has been carefully reviewed for technical accuracy. In the event that technical or typographical errors exist, Force Control reserves the right to make changes to subsequent editions of this document without prior notice to holders of this edition. The reader should consult Force Control if errors are suspected. In no event shall Force Control be liable for any damages arising out of or related to this document or the information contained in it.





TABLE OF CONTENTS

Section 1 - INTRODUCTION

1-1 General Description1

Section 2 - SPECIFICATIONS

2-1 Dimensions2
2-2 Lubrication2

Section 3 - INSTALLATION

3-1 Retro-Fit Installation3
 A. Installing the *UniMount* Gearbox.....3
 B. Installing The Starwheel4

Section 4 - REPAIR AND REPLACEMENT

4-1 Removing *UniMount* Gearbox5
4-2 *UniMount* Gearbox Disassembly5
 A. Removing Oil Seals (#26)5
 B. Removing Bearings (#28)5
 C. Removing Drive Gear (#20)6
 D. Removing Proximity Switch (#49)6
4-3 *UniMount* Gearbox Reassembly6
 A. Planetary Gearhead and Drive Gear6
 B. Installing Bearings (#28)6
 C. Installing Oil Seals (#26)6
 D. Installing Proximity Switch (#49)6
 E. Final Reassembly7
4-4 Reinstalling *UniMount* Gearbox Back Into Auto Catcher Frame7
4-5 Replacing Starwheels8
 A. Removing Starwheels8
 B. Installing A New Starwheel8

Section 5 - REPAIR PARTS

5-1 General Information8
5-2 Servo Motors8
5-3 Factory Rebuild Service8
5-4 Ordering Replacement Parts8
5-5 Name Plate and Model Number9

Parts List - Servo Driven *UniMount* Gearbox - Figure 5.110
Figure 5.1 - Servo Driven *UniMount* Gearbox11

ServoFit Precision Planetary Gearhead Installation Instructions.....12

Section 1 - INTRODUCTION

1-1 GENERAL DESCRIPTION

The Force Control *PosiDrive* Servo Driven *UniMount* Gearbox Drive Package is used to index the Starwheels of a roofing shingle catcher and/or stacker. The *PosiDrive* Servo Motor, initiated by a signal from the PLC and Servo Control, will index the Starwheels 90° quickly and accurately.

The Servo Driven *UniMount* Gearbox Drive Package contains:

1. *PosiDrive* Servo Motor.
2. Planetary Gearhead.
3. *UniMount* Gearbox.
4. (2) Starwheel Couplings.
5. Complete documentation for Installation, Operation Maintenance and Repair.

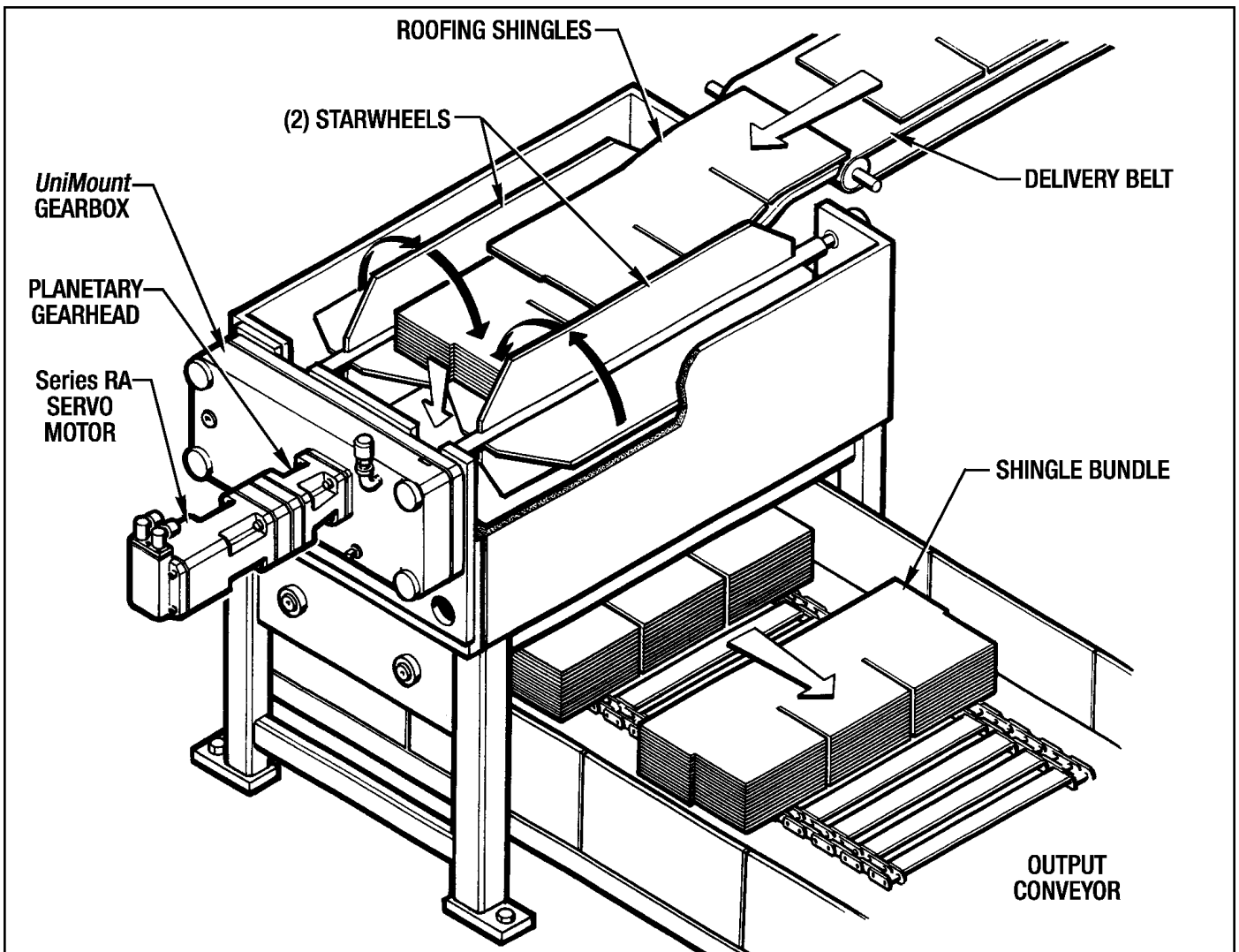

Figure 1.1 - Typical Application (Stacking Roofing Shingles)

Section 2 - SPECIFICATIONS

2-1 DIMENSIONS

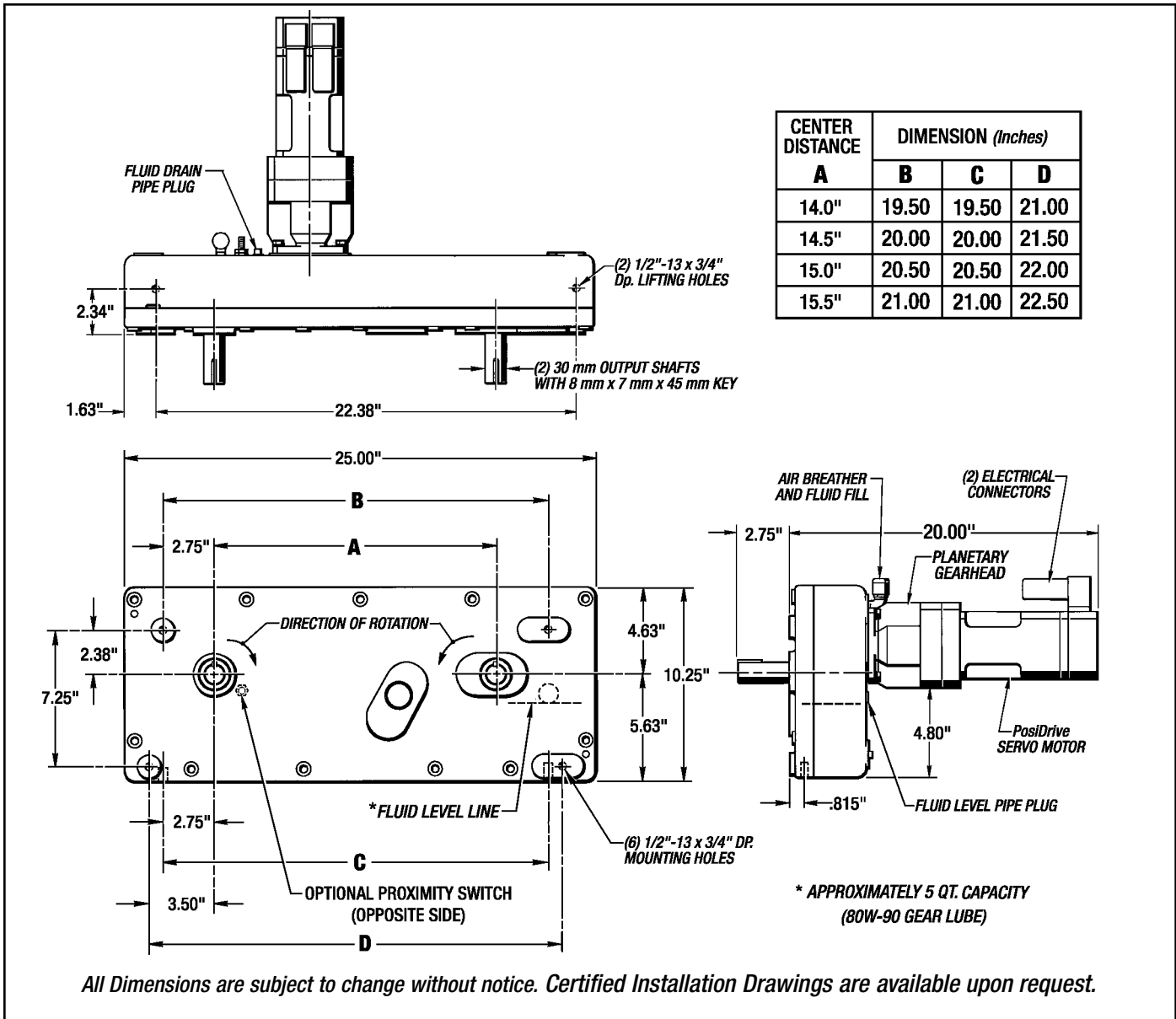

Figure 2.1 - UniMount Gearbox and Servo Motor Dimensions

2-2 LUBRICATION

Type of Fluid.....80W-90 Gear Lube

Quantity of Fluid..... Approx. 5 Quarts

A. Maintenance & Lubrication

1. **UniMount Gearbox** - The Gear Lube does not require any changing. Periodically check the fluid level and add if necessary.
2. **Planetary Gearhead** - No maintenance required, this is a sealed unit.
3. **PosiDrive Servo Motor** - No maintenance required.

Section 3 - INSTALLATION

3-1 RETROFIT INSTALLATION

A. Installing the UniMount Gearbox

1. Remove the old Gearboxes and the Posidyne Clutch/Brake Unit. The Drive Motor and other pneumatic equipment can be removed, but it is not necessary.
2. Also the lifting lug on the old Mounting Plate will have to be cut off and ground smooth so there will not be any interference in mounting the new Servo Driven UniMount Gearbox. (See the top half of Figure 3.1)

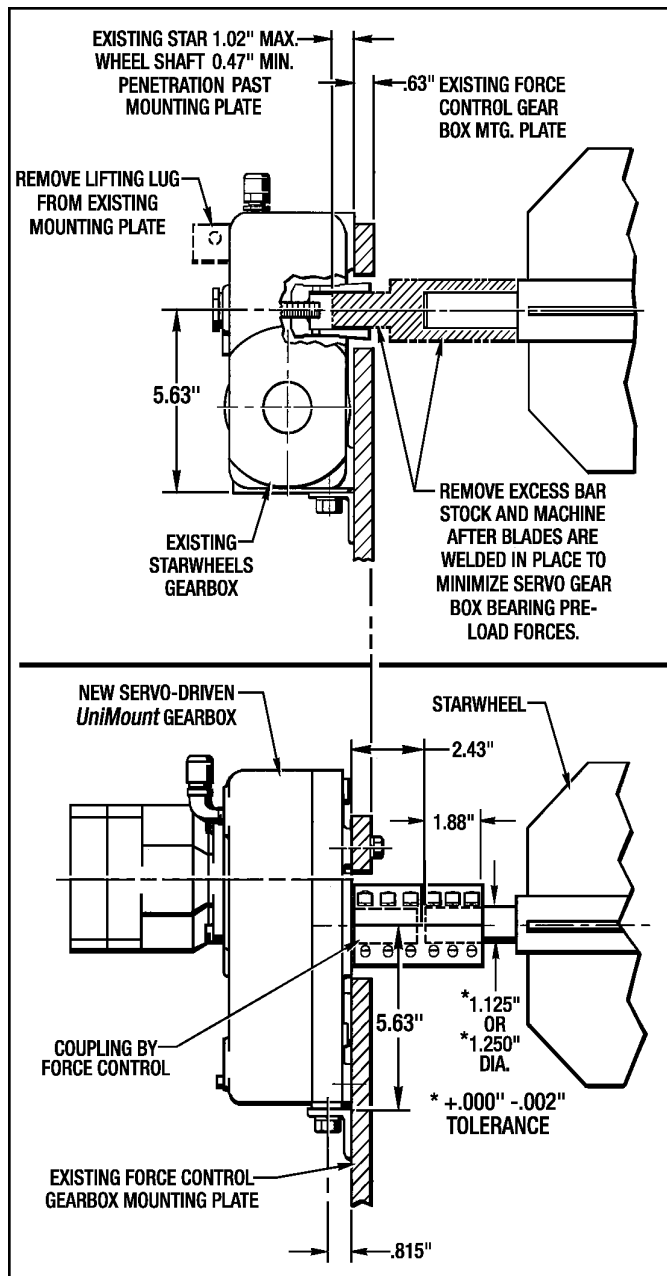

Figure 3.1 - Retrofit Installation for UniMount Gearbox

3. Remove excess bar stock from the Starwheel Shaft as shown in Figure 3.1.

IMPORTANT - Remove this excess bar stock and do any machining on the Starwheel Shafts after the blades are welded in place. This is Very Important to minimize any Gearbox Bearing Pre-load Forces.

4. Check the Fluid Level in the Gearbox and add if necessary.
5. Remove the red plastic plug from the Elbow (#37) and install the Air Breather (#38).
6. Bolt the new UniMount Gearbox to the Auto Catcher frame or mounting plate with (4) 1/2"-13 Hex Hd. Bolts and (4) 1/2" Lockwashers as shown in Figure 3.3.
7. Install the Starwheel Couplings (The bottom half and the L. H. Top Segment.) onto the Gearbox Output Shafts (#1) so the Couplings are approx. 1/16" from the Gearbox face as shown in Figure 3.2. Torque the (6) Screws to **27 Lb. Ft. (38 Nm)** in an even manner and in the pattern shown in Figure 3.2. Use **Blue Loctite #242**. Make sure the L.H. Gap and the R. H. Gap between the top segment and the bottom segment is the same on both sides as shown in Figure 3.2.

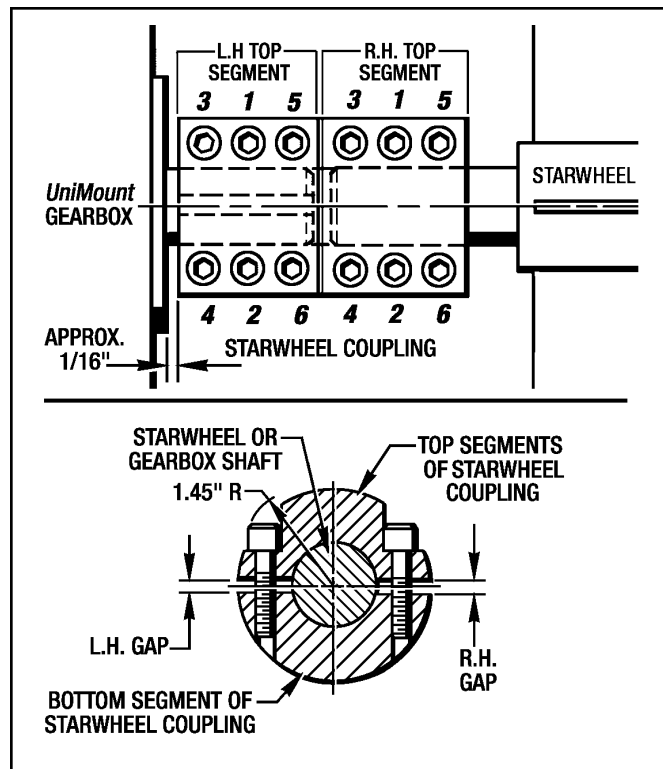

Figure 3.2 - Installing Drive Coupling

IMPORTANT - Make sure that you take out any end play in the gearbox before installing couplings.

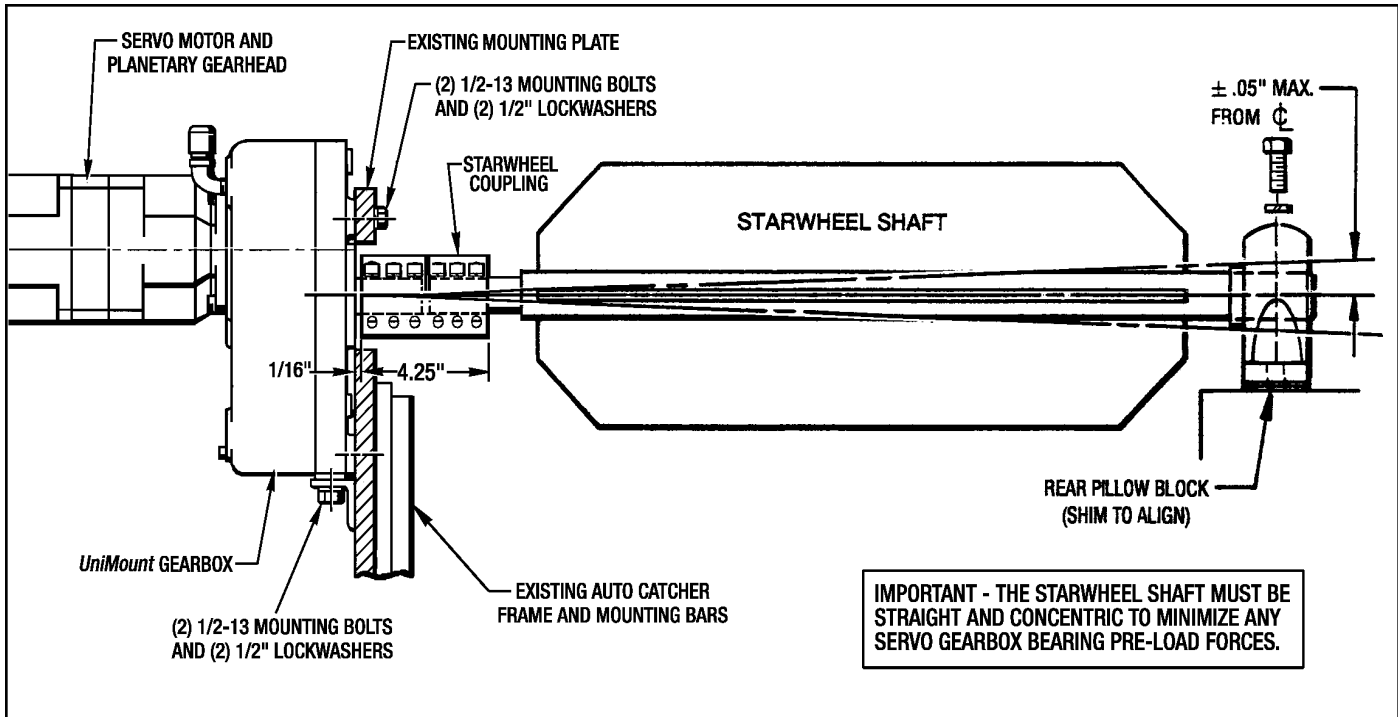

Figure 3.3 - Starwheel Shaft Alignment

B. Installing The Starwheel

1. Install the Rear Pillow Block Bearing on the new Starwheel shaft, but **do not lock it yet**.
2. Place the Starwheel shaft back into the Auto Catcher frame. **Do not bolt or lock the Rear Bearing yet.**

IMPORTANT - One very important consideration when installing the other Starwheel Shaft is that the blades have to be aligned with each other.

3. Attach the R.H. Top Segment of the Starwheel Coupling with the (6) Screws and Lockwashers. Use **Blue Loctite #242** on the screws. **Torque to 27 Lb. Ft. (38 Nm)** in an even manner and pattern shown in *Figure 3.2*. Again, make sure the L.H. Gap and the R. H. Gap between the top segment and the bottom segment is the same on both sides as shown in *Figure 3.2*.

NOTE - Always start with the (2) center screws and work outwards.

4. Rotate the Starwheel Coupling and Starwheel by hand. Check for bearing movement at the end of the shaft. Keep the shaft deflection less than .050" whenever possible for maximum bearing life in the *UniMount* Gearbox. (See *Figure 3.3* above.)
5. Attach the Rear Pillow Block Bearing to the Auto Catcher frame. Shim the Rear Pillow Block Bearing to support the Starwheel shaft to prevent damage to the Gearbox Bearings.
6. Lock the shaft to the Rear Bearings with the Shaft Cam Lock.
7. Turn on the electrical power and resume operation.

Section 4 - REPAIR AND REPLACEMENT

WARNING - Before attempting any repairs to the **UniMount Gear Box**, turn-off and lock-out all electrical power to the servo motor to avoid any possibility of personal injury.

Refer to **Section 5, Figure 5.1 - Servo UniMount Gearbox Assembly** for a visual reference to all parts described in this Repair Section.

4-1 REMOVING UniMount GEARBOX

1. Remove the Drain Plug (#36) from the Main Housing (#5) and drain all the fluid from the Gearbox. Save or discard as condition warrants.
2. Disconnect the electrical cables from the Servo Motor and the Proximity Switch.
3. Remove the plastic plug in the access hole in the Planetary Gearhead (#18) motor mounting flange. Rotate the Starwheels until the **Clamping Screw** in the Clamping Ring is aligned with the access hole in the side of the motor mounting flange. (See Figure 4.1).

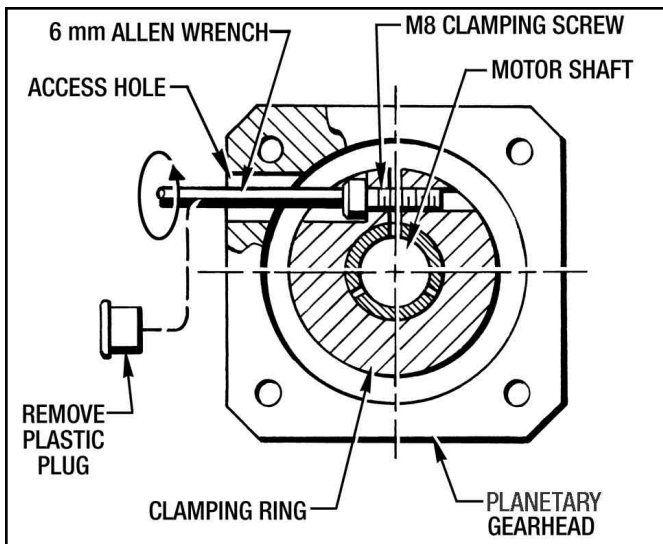

Figure 4.1 - Removing Servo Motor

4. Loosen the Clamping Screw with a 6 mm x 75 mm Lg. Allen Wrench.
5. Take out the (4) Screws (#44) and (4) Lockwashers (#45) and remove the Servo Motor from the Planetary Gearhead (#18).
6. Remove the (12) Screws from the both top halves of the Starwheel Couplings on the Gearbox Side and remove them. (See Figure 4.2)
7. Remove the (4) 1/2-13 Mounting Screws and Lockwashers that attaches the Gearbox to the Auto Catcher Mounting Plate or Frame. (See Figure 4.2)

Pull the Gearbox away from the Auto Catcher and set it on an appropriate work bench.

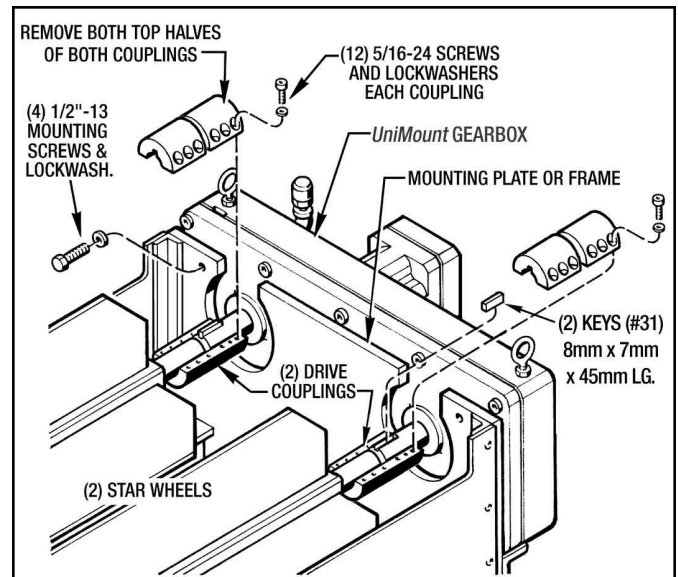

Figure 4.2 - Removing Gearbox From Auto Catcher

4-2 UniMount GEARBOX DISASSEMBLY

IMPORTANT - Only disassemble the Gearbox to the extent necessary to replace any damaged or worn parts.

1. Remove the (2) Keys (#31) from both Output Shafts (#1) and place some electrical tape over the keyways. Then apply a little white grease to the exposed Output Shaft (#1).
2. Remove the (11) Screws (#33) and (11) Lockwashers (#34). Carefully take the Output Housing (#3) and Gasket (#6) off the Main Housing (#5). Discard the Gasket (#6).

CAUTION - Be very careful not to damage the Oil Seal (#26) lip when lifting the Output Housing off the Main Housing.

A. Removing Oil Seals (#26)

1. Press the Oil Seals (#26) out of the Output Housing (#3) with an Arbor Press if they are damaged and have to be replaced.

B. Removing Bearings (#28)

1. If any of the (6) Bearings (#28) have to be replaced, they will have to be removed with a Bearing Puller as shown in Figure 4.3.

NOTE - The Idler Shaft (#2) is not shown but the removal process is the same.

2. Check all (4) Spur Gears (#19), (#20) and (#21) for any excessive wear or damage.

It is not recommended that you attempt to remove any of the Spur Gears from either the (2) Output Shafts (#1) or the Idler Shaft (#2). They can only be purchased and replaced as a sub-assembly.

3. Remove the Retaining Rings (#41) if they are not damaged. They are not furnished with the shaft and gear sub-assemblies and can be re-used.

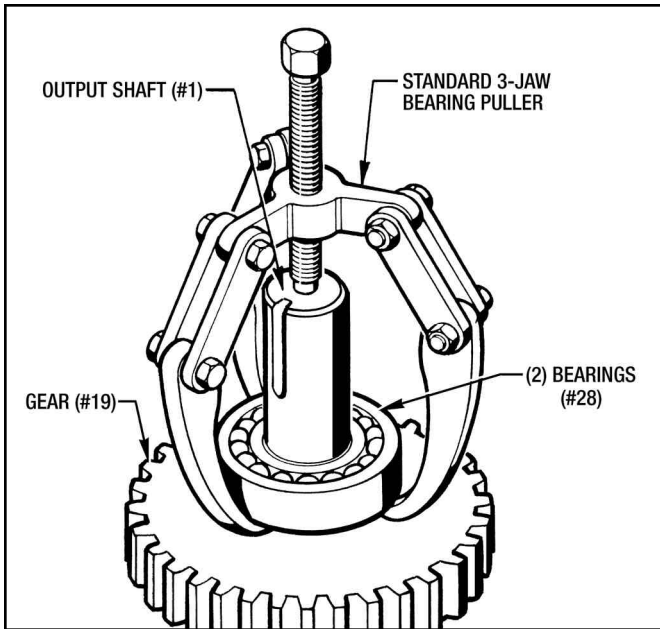

Figure 4.3 - Removing Bearings (#28)

C. Removing Drive Gear (#20)

If the Drive Gear (#20) has to be removed from the Planetary Gearhead (#18), use the following procedure as shown in Figure 4.4.

1. Remove the (4) Screws (#42) and (4) Lockwashers (#43).
2. Press the Planetary Gearhead (#18) out of the Drive Gear (#20) with an arbor press as shown in Figure 4.4

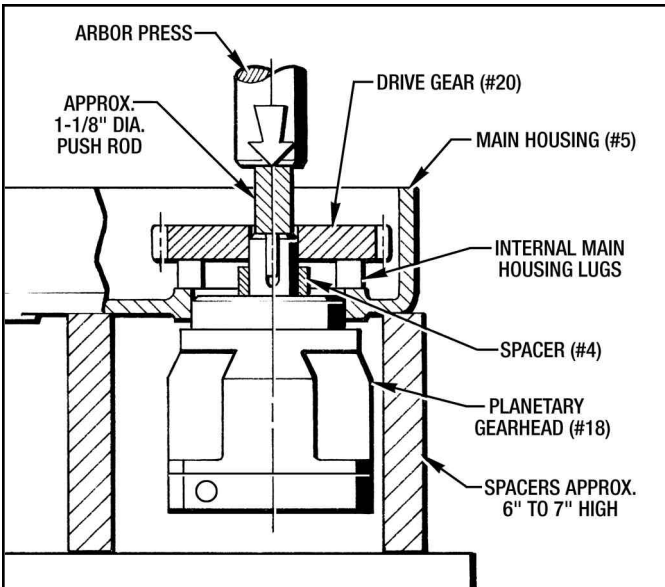

Figure 4.4 - Removing Drive Gear (#20)

3. Take the Spacer (#4) off the Planetary Gearhead (#18) shaft.

D. Removing Proximity Switch (#49)

1. Loosen the (2) Locknuts and unscrew the Proximity Switch (#49) from the Main Housing (#5).
2. Remove and discard the Seal Washer (#51).

4-3 UniMount GEARBOX REASSEMBLY

Make sure that all mounting surfaces of shafts, gears, bearings and housings are thoroughly cleaned before any reassembly is started.

A. Planetary Gearhead and Drive Gear

1. Attach the Planetary Gearhead (#18) to the Main Housing (#5) with (4) Screws (#42) and (4) Lockwashers (#43). **Torque to 22 Lb. Ft. (30Nm).**
2. Set the Main Housing (#5) with the inside facing up. Be sure to support the housing with adequate spacers so that it is level and stable.
3. Place the Spacer (#4) on to the Planetary Gearhead (#18) Shaft.
4. Heat the Drive Gear (#20) to approx. 290° F and install it on the input shaft. The Gear should rest on the Spacer (#4).

CAUTION - Be sure to wear adequate protective gloves when handling heated parts. Do not overheat.

B. Installing Bearings (#28)

This procedure is the same for the (2) Output Shafts (#1) and the Idler Shaft (#2).

1. Install the (2) Retaining Rings on the shaft if they were previously removed.
2. Heat the Bearing to approx. 250° F.

CAUTION - Be sure to wear adequate protective gloves when handling heated parts. Do not overheat.

3. Clean with **Primer T**. Apply **Green Loctite #680** to the mating surface on the shaft.
4. Drop the Bearing (#28) on to the shaft until it rests against the Retaining Ring (#41).
5. Clean off any excess Loctite.
6. Turn the shaft over and install the other Bearing (#28) with the same procedure.

C. Installing Oil Seals (#26)

1. Make sure that both oil seal bores are thoroughly cleaned.
2. Apply **Permatex #3 Sealant** to the oil seal bores. **Be very careful not to get any sealant on the oil seal lips.**
3. Install the (2) Oil seals (#26) into the Output Housing (#3) with an arbor press.

D. Installing Proximity Switch (#49)

(See Figure 4.5)

1. Align the Hex Hd. Screw (#47) installed in the Driven Gear (#52) with the proximity switch hole.
2. Place a new Seal Washer (#51) on the Proximity Switch (#49).
3. Thread the Proximity Switch (#49) all the way in until it contacts the head of the Screw (#47), then unscrew the Proximity Switch (#49) back out (2) complete revolutions.
4. Tighten down the (2) Locknuts on the Proximity Switch (#49) to lock it in position.

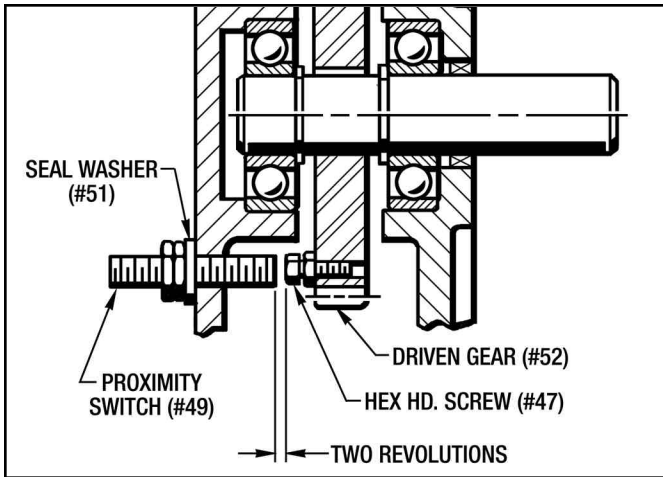

Figure 4.5 - Installing Proximity Switch (#49)

E. Final Reassembly

1. Place the (2) Output Shaft Sub-Assemblies and the Idler Shaft Sub-Assembly into their respective bearing bore.

IMPORTANT - Make sure that all the gears are aligned and mesh properly with each other.

2. Place a new Gasket (#6) in position on the Main Housing (#5). Use the (2) Pins (#35) for proper positioning.
3. Apply a little white grease to both Oil Seal (#26) sealing lips. Place a piece of electrical tape over both keyways and then apply a little white grease over the tape and both Output Shafts (#1).
4. Carefully lower the Output Housing (#3) down over the (2) Output Shafts (#1) and into position on the Gasket (#6).

CAUTION - Be very careful not to damage the Oil Seal Lips.

5. Attach the Output Housing (#3) with (11) Screws (#33) and (11) Lockwashers (#34). **Torque to 60 Lb. Ft. (81 Nm).**
6. Install the Drain Plug (#36) into the back of the Main housing (#5).
7. Remove the Fluid Level Pipe Plug (#39) and the Breather (#38) and fill the Gearbox with fresh 80W-90 Gear Lube until it starts to run out the Fluid Level Pipe Plug (#39) hole.
8. Re-install the Fluid Level Pipe Plug (#39) and the Breather (#38).
9. De-grease and install the (2) 8mm x 7mm x 45mm Lg. Keys (#31) into the Output Shafts (#1).

4-4 RE-INSTALLING UniMount GEARBOX INTO THE AUTO CATCHER FRAME

1. De-grease both Starwheel Shafts and the bore of the Drive Coupling.
2. Place the Gearbox back into position on the Auto Catcher Frame or Mounting Plate. Attach the Gearbox with (4) 1/2"-13 Mounting Screws and Lockwashers. **Torque to 60 Lb. Ft. (81Nm).**
3. Coat the Output Shaft, Coupling I.D., Coupling Screws and the tapped holes with **Blue Loctite #242**. This will act as a rust inhibitor. **Do not use "Never Seize" on the coupling.**

4. Re-attach both Drive Couplings that was removed with the (24) 5/16"-24 x 1-3/8" Lg. Cap Screws and Lockwashers. The Starwheel Couplings should be approx. 1/16" from the Gearbox face as shown in Figure 4.6.

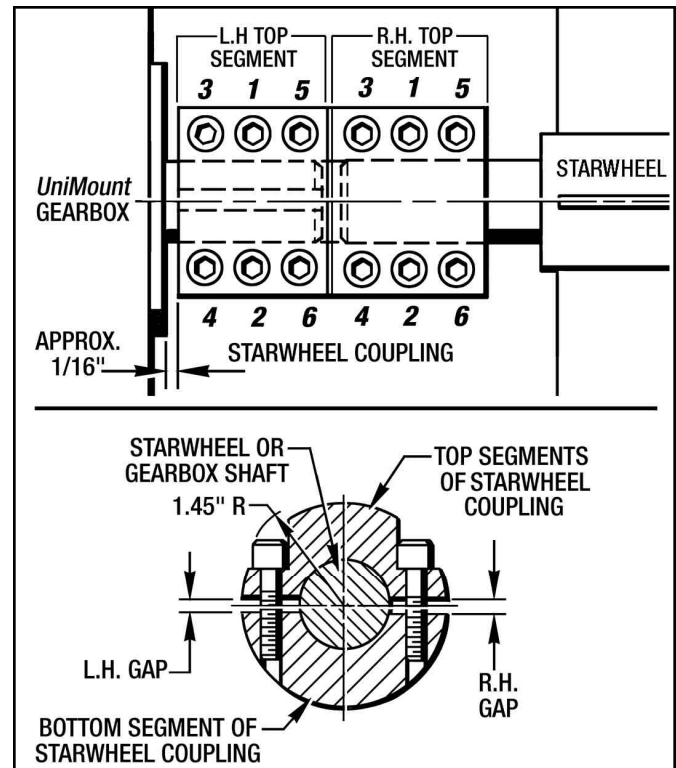

Figure 4.6 - Torque Pattern for Drive Coupling Screws

IMPORTANT - Align Starwheels with each other before tightening screws.

Make sure that you take out any end play before installing couplings.

5. Torque in an even manner and pattern as shown in Figure 4.6. **Torque to 27 Lb. Ft. (38 Nm).** Make sure the L.H. Gap and the R. H. Gap between the top segment and the bottom segment is the same on both sides as shown in Figure 4.6.

NOTE - When the Starwheel Coupling Screws are torqued properly, it takes **250 Lb. Ft.** of torque to slip the Starwheels in the coupling.

6. Mount the Servo Motor to the Planetary Gear Reducer as per **ServoFit Planetary Gearhead Installation Sheet** located in back of this manual.
7. Make sure the servo motor output shaft is properly degreased.
8. Attach the Servo Motor with the (4) Screws (#44) and (4) Lockwashers (#45). **Torque to 22 Lb. Ft. (30 Nm).**
9. Attach the electrical cables to the Servo Motor and turn the power back on.
10. Cycle the Servo Motor several times to make sure that everything is properly aligned and installed.

4-5 REPLACING STARWHEELS

WARNING - Turn-Off and Lock-Out all electrical power to the Servo Motor.

A. Removing Starwheels

The following procedure is only given for the replacement of one (1) Star Wheel. The procedure is exactly the same for the other one.

1. Remove the top half segment of the Starwheel Coupling on the Starwheel side.
2. Remove the mounting screws for the Rear Pillow Block.
3. Lift the whole Starwheel shaft out of the Auto Catcher frame and place it on a suitable workbench.
4. Loosen the Shaft Cam Lock and remove the Pillow Block Bearing from the Starwheel shaft.

B. Installing A New Starwheel

1. Install the Rear Pillow Block Bearing on the new Starwheel shaft, but **do not lock it yet**.
2. Replace the Starwheel back into the Auto Catcher frame. **Do not bolt or lock the Rear Bearing yet.**
3. Coat the Coupling I.D., Coupling Screws and the tapped holes with **Blue Loctite #242**. This will act as a rust inhibitor. **Do not use "Never Seize" on the coupling.**

4. Attach the top segment of the Starwheel Coupling with the (6) Screws and Lockwashers. **Torque to 27 Lb. Ft. (38 Nm)** in an even manner and pattern shown in *Figure 4.5*. Make sure the L.H. Gap and the R. H. Gap between the top segment and the bottom segment is the same on both sides as shown in *Figure 4.5*.

NOTE - Always start with the (2) center screws and work outwards.

5. Rotate the Starwheel Coupling and Starwheel by hand. Check for bearing movement at the end of the shaft. **Keep the shaft and bearing deflection less than .05" whenever possible for maximum gearbox bearing life.**(See *Figure 3.3*.)
6. Attach the Rear Pillow Block Bearing to the Auto Catcher frame. Shim the Rear Pillow Block Bearing to support the Starwheel shaft to prevent damage to the Gearbox Bearings.
7. Lock the shaft to the Rear Bearings with the Shaft Cam Lock.
8. Install the other Starwheel Shaft with the exact same procedure.

IMPORTANT - One very important consideration when installing the other Starwheel Shaft is that the blades have to be aligned in exactly the same position as the first one

9. Turn on the electrical power and resume operation.

Section 5 - REPAIR PARTS

5-1 GENERAL INFORMATION

This section illustrates, lists and describes all parts for **PosiDrive UniMount Gearbox**. Parts are identified on the exploded views with Part Reference Numbers. These Numbers correspond to the Part Reference Number given in the Parts Lists. The Part Name and Quantity Used is also given in the Parts List. This Part Reference Number, Part Name and Quantity should be used when ordering Replacement Parts.

5-2 SERVO MOTORS

The Servo Motors used with these *UniMount* Gearboxes can only be repaired or furnished by Force Control Industries, Inc.

5-3 FACTORY REBUILD SERVICE

Reconditioning Service is offered by Force Control Industries, Inc. at the factory. A complete factory rebuild will be 50% the cost of a new unit if the housings are reusable. If Housings need to be replaced, there will be an additional cost.

Contact Force Control Industries, Inc. for authorization and shipping instruction before returning a drive unit for this service. Force Control cannot be responsible for units returned to the factory without prior notice and authorization.

Care must be given to the packing of returned drives. Always protect mounting feet by attaching to a skid. Shipment-damaged drives always delays repairs. It is usually impossible to recover damage costs from the carrier. When possible, describe the problem experienced on your shipping papers.

Return to: **Force Control Industries, Inc.**
3660 Dixie Highway
Fairfield, Ohio 45014
Phone: (513) 868-0900
Fax: (513) 868-2105
E-Mail: info@forcecontrol.com
Web: www.forcecontrol.com

5-4 ORDERING REPLACEMENT PARTS

When ordering replacement parts, please specify all of the following information:

1. Gearbox Model Number (On the Name Plate.)
2. Gearbox Serial Number (On the Name Plate.)
3. Part Reference Number (From the parts list or exploded view drawing.)
4. Part Name (From the parts list.)
5. Quantity (From the parts list.)
6. Complete Shipping Information.

Failure to include information for items 1 through 6 will only delay your parts order. Unless another method is specified for item 6, parts weighing less than 150 Lbs. will be shipped United Parcel Service. Parts weighing more than 150 Lbs. will be shipped Motor Freight. Air freight and other transportation services are available but only if specified on your order.

5-5 NAME PLATE & MODEL NUMBERS

Force Control Industries, Inc.
 Fairfield, Ohio
 For Service/Parts Call
 513-868-0900



Model No.

Serial No.

PosiDrive UniMount Gearbox Model Number

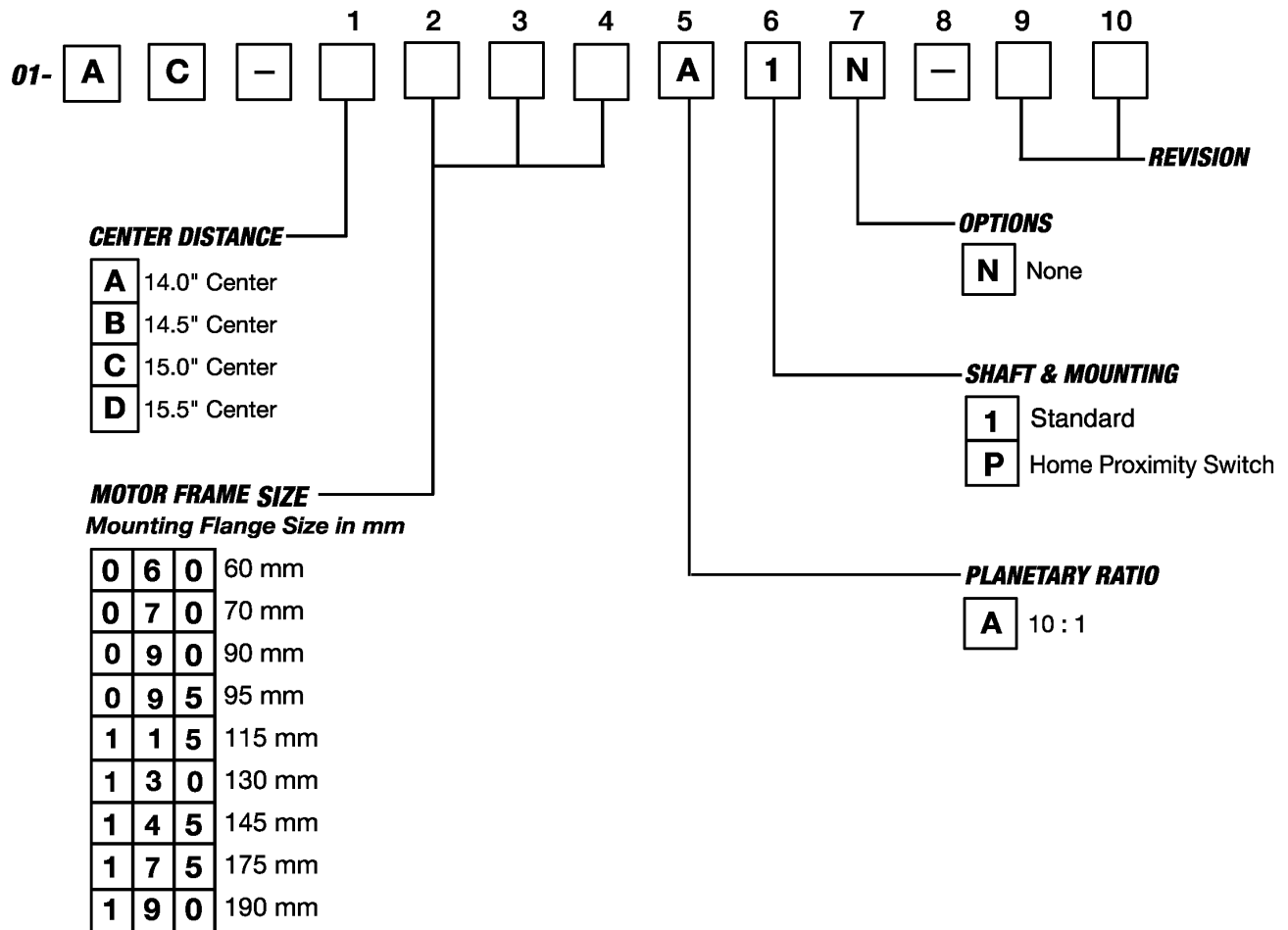

Parts List

SERVO DRIVEN *UniMount* GEARBOX

REF. No.	PART NAME	QTY.	REF. No.	PART NAME	QTY.
*1	Output Shaft, 30 mm Dia.....	2	*32	Key, 8 mm x 7 mm x 20 mm Lg..	2
*2	Idler Shaft, 30 mm Dia.....	1	33	Soc. Hd. Cap Screw, 1/2"-13 x 1-1/2" Lg.	11
3	Output Housing		34	Lock Washer, 1/2" Hi-Collar.....	11
	14" Center Distance	1	35	Dowel Pin, 3/8" Dia. x 1-1/4" Lg.	2
	14.5" Center Distance	1	36	Magnetic Pipe Plug, Sq. Hd.-1/4" NPT.....	1
	15" Center Distance	1	37	90° Street Elbow, 1/4" NPT	1
	15.5" Center Distance	1	38	Breather	1
4	Spacer Ring	1	39	Pipe Plug, 3/4" NPT	1
5	Main Housing		41	Retaining Ring	6
	14" Center Distance	1	42	Soc. Hd. Cap Screw, M8-1.25 x ? Lg.....	4
	14.5" Center Distance	1	43	M8 Ribbed Lock Washer	4
	15" Center Distance	1	44	Soc. Hd. Cap Screw, M8-1.25 x ? Lg.....	4
	15.5" Center Distance	1	45	M8 Ribbed Lock Washer	4
6	Main Gasket	1	*47	Hex Hd. Screw, 1/4"-20 x 3/4" Lg.	1
18	Planetary Gear Reducer	1	48	Closure Cap (<i>Without Proximity Switch</i>).....	1
*19	Driven Gear, 30 mm Dia. Bore	2	*49	Proximity Switch	1
20	Drive Gear, 32 mm Dia. Bore	1	50	Cable Set, 2 Meters lg.....	1
*21	Idler Gear, 30 mm Dia. Bore	1	*51	Seal Washer, M12	1
26	Oil Seal	2	*52	Driven Gear, 30 mm Bore (<i>With Pickup Bolt</i>)..	1
28	Ball Bearing	6	*53	Hex Nut, 1/4-20	1
31	Key, 8 mm x 7 mm x 45 mm Lg..	2			

***NOTES:**

1. The Driven Gear (#19), Output Shaft (#1) and the Key (#32) can only be ordered as a factory assembled sub-assembly. Use Part No. **02-60-902-00** to order this Sub-Assembly

2. The Driven Gear (#52), Output Shaft (#1), Key (#32), Hex Hd. Screw (#47) and Hex Nut (#53) can only be ordered as a factory assembled sub-assembly. Use Part No. **02-60-904-00** to order this Sub-Assembly.

3. The Idler Gear (#21) and the Idler Shaft (#2) can only be ordered as a factory assembled sub-assembly. Use Part No. **02-60-903-00** to order this Sub-Assembly.

4. When ordering a Proximity Switch (#49), also order a Seal Washer (#51).

5. Use the following **Part Numbers** to order a Starwheel Coupling:

30 mm to 1-1/8" Dia Shafts.....#103-60-010

30 mm to 1-1/4" Dia Shafts.....#103-60-011

SERVO DRIVEN *UniMount* GEARBOX

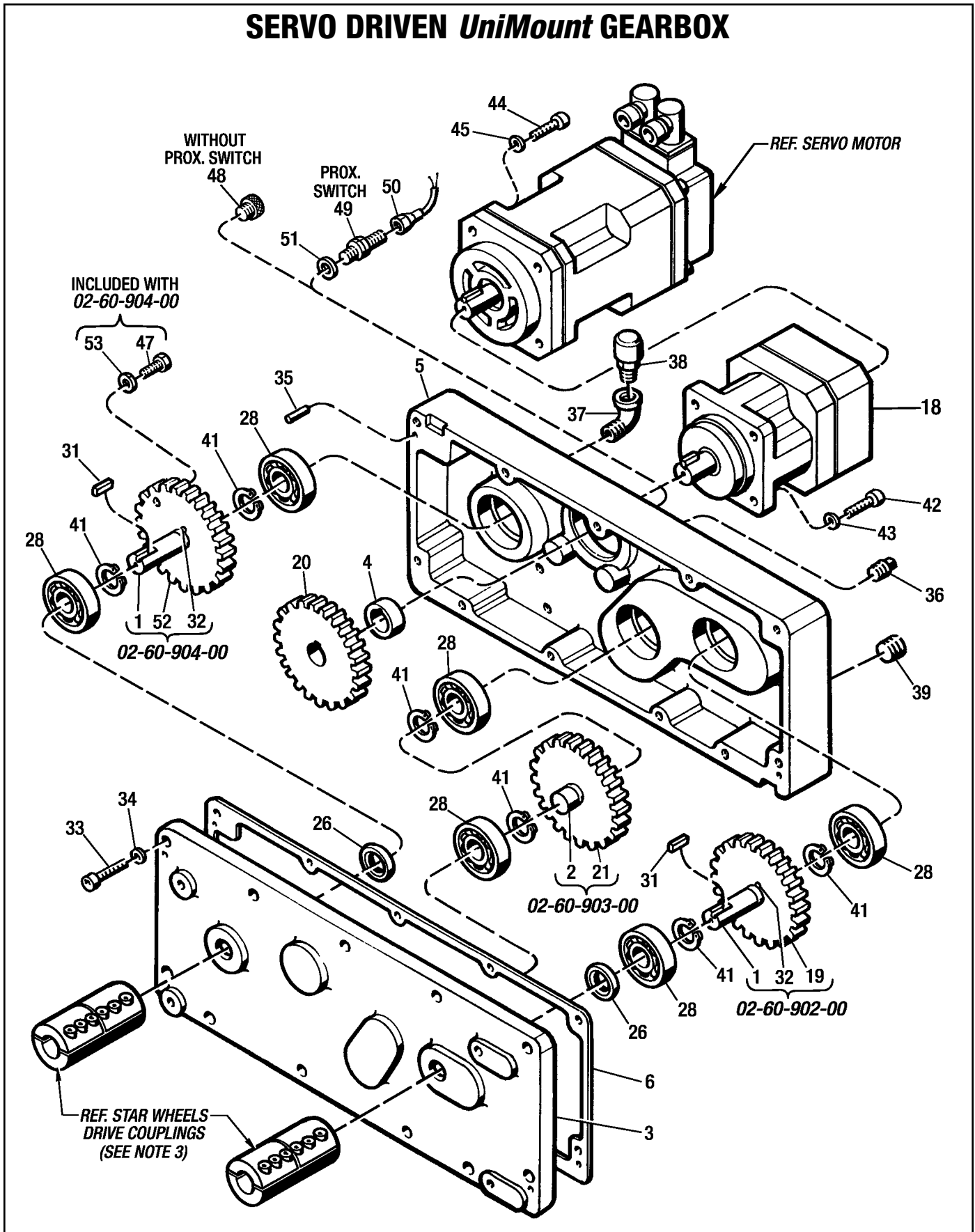
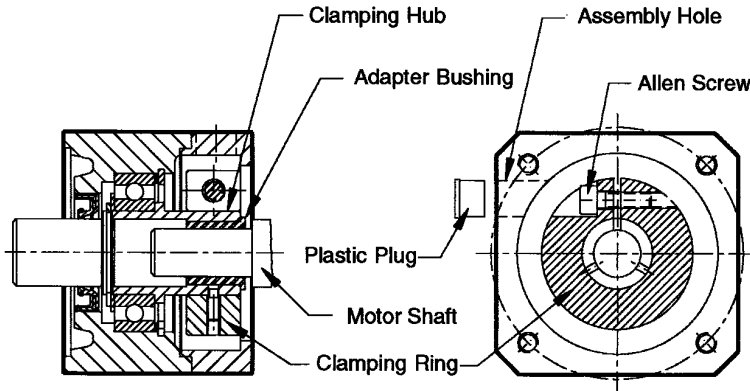

Figure 5.1 - Servo Driven UniMount Gearbox



ServoFit Precision Planetary Gearhead Installation Instructions



General Information

Servo motors are mounted to ServoFit™ Precision Planetary Gearheads by using a TriAdapt™ motor adapter. This patented adapter requires no key but uses a triple split collet to clamp the shaft. A split bushing is included when the motor shaft is smaller than the input bore in the gearhead.

Tolerances for the motor must be ISO j6 on the pilot diameter and ISO k6 on the motor shaft. The motor does not require a key but shaft runout, pilot concentricity and perpendicularity are important.

Assembly of Gearhead

Important: Clean the motor shaft with degreaser to remove any film of oil or grease.

- Carefully remove the plastic plug from the assembly hole in the motor plate.
- Visually align the assembly hole in the motor plate with the Allen screw in the clamping ring by turning the gearhead output shaft.
- If an adapter bushing is needed, degrease the bushing inside and outside.
Align the slot in the adapter bushing with the slot in the clamping hub. Slide the bushing into the input bore until the collar of the bushing touches the shaft end.

- Place the gearhead (with the bushing installed where necessary) onto the motor shaft. (Align the slot in the clamping hub with the keyway in the motor shaft, where necessary.) Support the gearhead while sliding it onto the motor shaft.

IT IS VERY IMPORTANT THAT THE GEARHEAD IS NOT FORCED ONTO THE SHAFT.

- With the motor flange tight against the gearhead motor plate, tighten the Allen screw in the clamping ring slightly to concentrically adjust the gearhead input bore to the motor shaft.
- Bolt the motor flange to the gearhead motor plate using the recommended bolt length as specified. Tighten the motor bolts to the recommended tightening torque shown in Table No. 1.
- If possible, let the motor turn several revolutions to seat the TriAdapt™ clamping ring on the motor shaft.

- Tighten the Allen screw to the recommended tightening torque shown in Table No. 1.
- Insert the plastic plug into the assembly hole.

Table No. 1 Capscrew Tightening Torque and Wrench Length

Capscrew Size	Reach Length*	Tightening Torque		Allen Wrench	
		Nm.	in. lbs.	Size	Length
M5	10 mm	5.9	52	4	40 mm
M6	12 mm	10	88	5	50 mm
M8	16 mm	25	221	6	75 mm
M10	20 mm	40	354	8	90 mm
M12	24 mm	60	531	10	120 mm
M16	32 mm	150	1327	—	—

* The reach length shown above for each capscrew size is the recommended length of bolt thread engagement into a stock motor plate. The length of the motor bolt should be the sum of the motor flange thickness and the capscrew thread reach length.

The wrench length is the minimum length needed to engage the Allen screw in the clamping ring. See illustration.

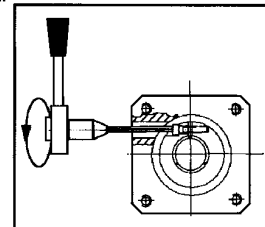

Table No. 2 Tolerances for Motors

k6 - Pilot Diameter	Metric (µm)	Imperial (ins.)
over 30 - 50	+18 / +2	+0.0007 / +0.0008
over 50 - 80	+21 / +2	+0.0008 / +0.0008
over 80 - 120	+25 / +3	+0.0010 / +0.0012
over 120 - 180	+28 / +3	+0.0011 / +0.0012
over 180 - 250	+33 / +4	+0.0013 / +0.0016
j6 - Shaft Diameter	Metric (µm)	Imperial (ins.)
over 10 - 18	+8 / -3	+0.0003 / -0.00012
over 18 - 30	+9 / -4	+0.00035 / -0.00016
over 30 - 50	+11 / -5	+0.0004 / -0.0002

June 9, 2000

Printed in U.S.A.

Form No. 2008

Stober Drives Inc. • 1781 Downing Drive • Maysville, KY 41056 • Phone: 606 759-5090 • FAX: 606 759-5045 • www.stober.com • E-mail: sales@stober.com

FORCE CONTROL INDUSTRIES, INC.

Worldwide Leader in Oil Shear Technology.

*Providing Today's Industries With:
Oil Shear Clutch/Brake Drives
and Electronic Servo Drives
That Delivers:
Flexibility • Efficiency
Endurance • Performance
Dependability*

“Built to Last - Guaranteed to Perform”



FORCE CONTROL INDUSTRIES, INC.

MAIN OFFICE

P.O. Box 18366
Fairfield, Ohio 45018

3660 Dixie Highway
Fairfield, Ohio 45014

Tel: (513) 868-0900
Fax: (513) 868-2105

E-Mail: info@forcecontrol.com
Web Site: www.forcecontrol.com