

APC-2006

All Products Catalog

Section 14
Application
Engineering Services



Force Control Industries, Inc.

Main Office and Manufacturing Plant

3660 Dixie Highway
Fairfield, Ohio 45014

Telephone: (513) 868-0900

Fax: (513) 868-2105

E-Mail: info@forcecontrol.com

Web: www.forcecontrol.com



MEX (55) 53 63 23 31 MTY (81) 83 54 10 18
QRO (442) 1 95 72 60 ventas@industrialmagza.com

Worldwide Leader In
Oil Shear Technology

Section 14 Application Engineering Services

Force Control Industries, Inc., over the past 45 years has developed an expertise in solving tough industrial drive applications. For this reason many customers have expressed a desire to have **Force Control** design and build the complete package that solves their unique and often complex drive problems. These applications range from high cycle precise positioning drives to dynamometers that can absorb 20,000 Lb. Ft. of torque.

Force Control Industries, Inc. will modify a standard product to accommodate metric or odd shaft sizes. **Force Control** can build a clutch/brake with an integral gear box or design and fabricate a mounting base for easy retrofit. Whatever it takes to solve those tough applications. Some of these special applications are shown below and on the next page.

Solving those tough drive applications has led **Force Control** to add a Controls Department that includes software development as well as design and assembly of the control. This led to the development of a standard line of

controls. As customer needs arose even the standard controls have been modified to handle the tough applications.

Force Control even has service technicians that will go into the field and collect the required data it takes to design and build the drive. This can include taking strip chart recordings to determine cycle times, torque and horsepower requirements, as well as product flow rates. They will take measurements so a mounting base can be fabricated for an easy retrofit. They are even available to help with the start-up of the new drive.

Force Control Industries, Inc. will continue through the next century to develop new products, expand the drive fabrication, add special modifications to standard drives and grow in the electronics and control area to benefit our customers.

If you think it can't be done - Ask Force Control Industries, Inc.

Auto Catcher Servo Drive Assembly

Tandem Shingle Auto Catchers using two Uni-Mount Gearboxes and two PosiDrive Servo Motors installed in a Roofing Shingle Manufacturing Plant.



Fiberglass Retrofit Cut-Off Drive

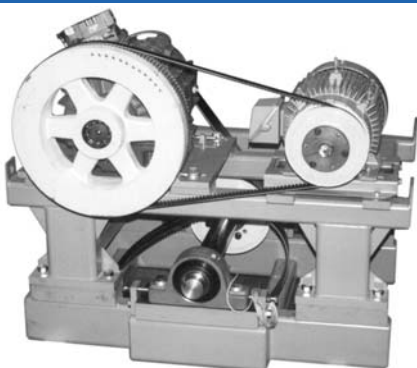

Specifically designed ultra quick Posidyne Clutch/Brake with flywheel and welded tubular base completely assembled.

Palletizer

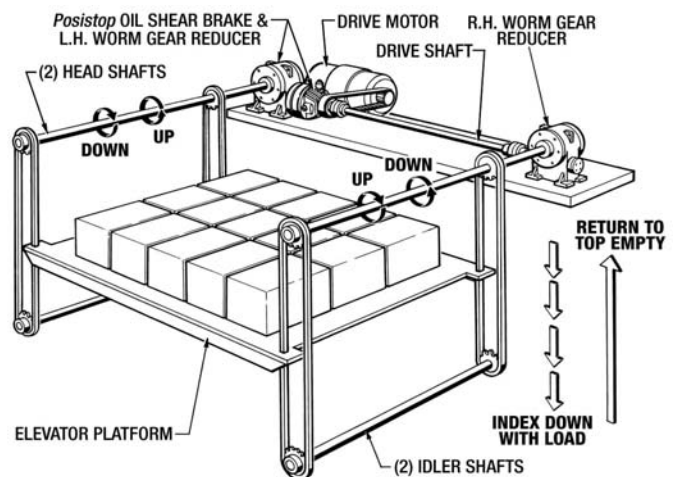

A Complete Drive Package

A common drive package consisting of a Multi Speed Drive Type II (MSDr), primary and secondary drive motors with a 90° gear reducer all mounted on a common machined base.

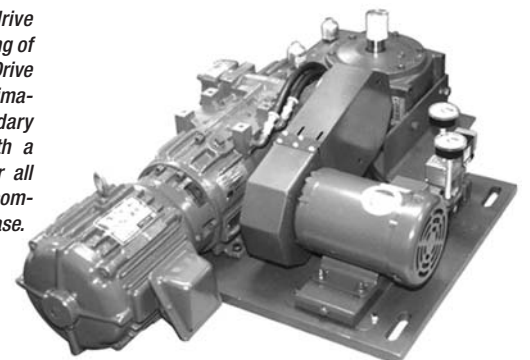

Shingle Blender Drive

Modified 2.5 Posidyne Clutch/Brakes for high cycle quick response with special self cleaning gears. The complete package is mounted on a welded and ground base for perfect alignment.

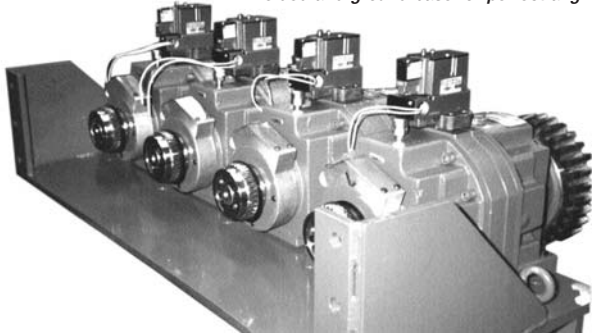

Blender Drive Control

A primary Control for the blend drops providing consistency over variable speed ranges.



Dynamometer Brake with Frame

Positorq Absorber Brake with torque arm and load cell mounted on a welded steel base.

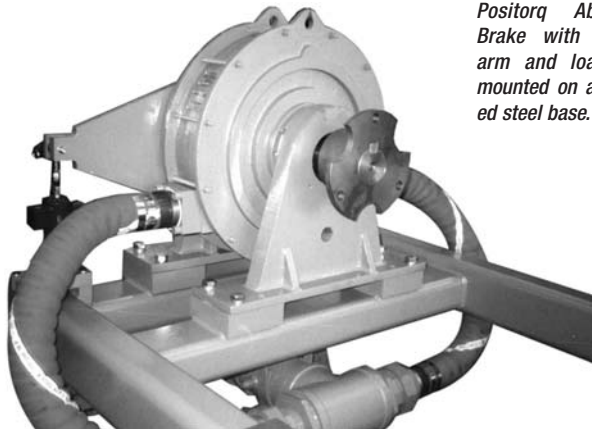

Forced Lube Accumulator Cooling Unit

Special one-shot high volume forced lube system for high thermal short duration loads.

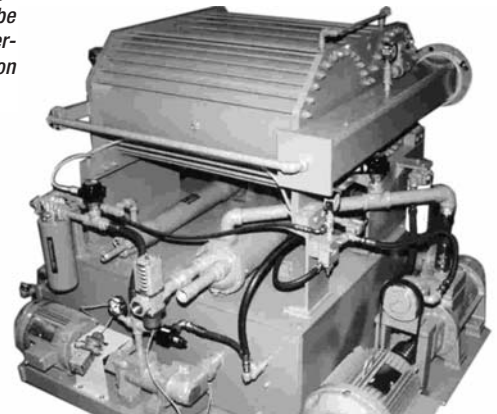

Greenlee Retrofit Ball Screw Drive

Special retrofit drive packages to fit existing applications which includes the clutch/brake, drive motor and mounting adapter for easy assembly.

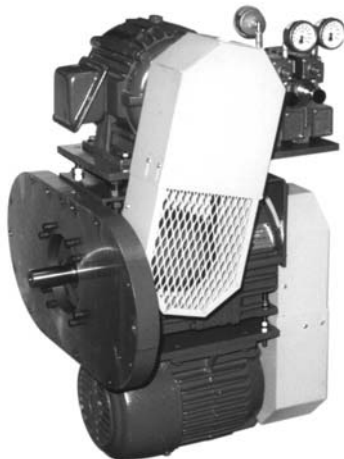

Ferris Wheel Drive Package

Multi-speed Drive and Gear Reducer integrally mounted on a fabricated machined base for a complete drive package used by the automotive industry in an engine block washing line.

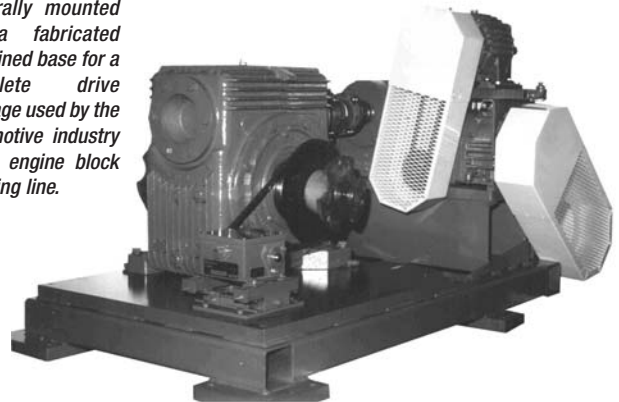

If you think it can't be done - Ask Force Control Industries, Inc.

14