



502-AC-002-03



AUTO CATCHER

WITH

CLPC™ CONTROL Series II
(With Zero Power RAM)

OPERATION AND SERVICE MANUAL

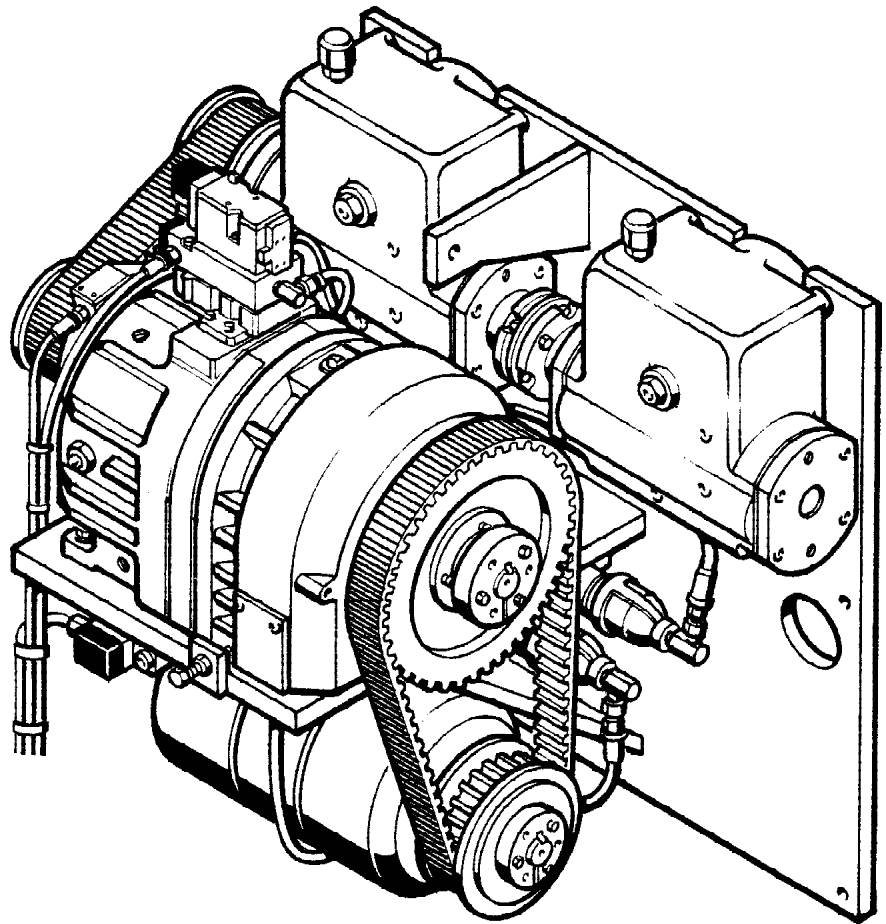

WARNING - Read this manual before any installation, maintenance and operation.

**MANUFACTURERS OF MECHANICAL AND
FORCE CONTROL INDUSTRIES, INC. ELECTRICAL POWER TRANSMISSION EQUIPMENT**



MEX (55) 53 63 23 31 MTY (81) 83 54 10 18
QRO (442) 1 95 72 60 ventas@industrialmagza.com

Limited Warranty

Force Control Industries, Inc. ("Force Control") warrants its products to be free from defects in material and workmanship under normal and proper use for a period of one year from the date of shipment. Any products purchased from Force Control that upon inspection at Force Control's factory prove to be defective as a result of normal use during the one year period will be repaired or replaced (at Force Controls' option) without any charge for parts or labor. This limited warranty shall be void in regard to (1) any product or part thereof which has been altered or repaired by a buyer without Force Control's previous written consent or (2) any product or part thereof that has been subjected to unusual electrical, physical or mechanical stress, or upon which the original identification marks have been removed or altered. Transportation charges for shipping any product or part thereof that the buyer claims is covered by this limited warranty shall be paid by the buyer. If Force Control determines that any product or part thereof should be repaired or replaced under the terms of this limited warranty it will pay for shipping the repaired or replaced product or part thereof back to the buyer. EXCEPT FOR THE EXPRESS WARRANTY SET OUT ABOVE, FORCE CONTROL DOES NOT GRANT ANY WARRANTIES EITHER EXPRESSED OR IMPLIED, INCLUDING IMPLIED WARRANTIES OF MERCHANTABILITY OR FITNESS FOR USE. The warranty obligation set forth above is in lieu of all obligations or liabilities of Force Control for any damages. Force Control specifically shall not be liable for any costs incurred by the buyer in disconnecting or re-installing any product or part thereof repaired or replace under the limited warranty set out above. FORCE CONTROL EXPRESSLY EXCLUDES ALL LIABILITY FOR ANY INDIRECT OR CONSEQUENTIAL DAMAGES THE BUYER MAY SUSTAIN IN CONNECTION WITH THE DELIVERY, USE, OR PERFORMACE OF FORCE CONTROL PRODUCTS. Under no circumstances shall any liability for which Force Control is held responsible exceed the selling price to the buyer of the Force Control products that are proven to be defective. This limited warranty may be modified only in writing signed by a duly authorized officer of the company. This limited warranty applies exclusively to Force Control products; warranties for motors and gear reducers and other component parts may be provided by their respective manufactures. Any legal action for breach of any Force Control warranty must be commenced within one year of the date on which the breach is or should have been discovered.

A Return Goods Authorization (RGA) number must be obtained from the factory and clearly marked on the outside of the package before any equipment will be accepted for warranty work. Force Control will pay the shipping costs of returning the owner parts that are covered by warranty.

Force Control believes that the information in this document is accurate. The document has been carefully reviewed for technical accuracy. In the event that technical or typographical errors exist, Force Control reserves the right to make changes to subsequent editions of this document without prior notice to holders of this edition. The reader should consult Force Control if errors are suspected. In no event shall Force Control be liable for any damages arising out of or related to this document or the information contained in it.

TABLE OF CONTENTS

Section 1 SYSTEM DESCRIPTION

1-1 GENERAL DESCRIPTION	2
1-2 <i>Posidyne</i> CLUTCH/BRAKE UNIT	3
1-3 POSITIONING ENCODER ASSEMBLY	3
1-4 CLPC CONTROL Series II	3
1-5 RIGHT ANGLE GEAR BOXES	4
1-6 PNEUMATICS	4

Section 2 INSTALLATION

2-1 DRIVE UNIT INSTALLATION	5
2-2 INSTALLATION OF STARWHEEL SHAFT INTO THE GEARBOX COLLET	6
2-3 REMOVAL OF STARWHEEL SHAFT FROM THE GEARBOX COLLET	6
2-4 JUNCTION BOX MOUNTING	6
2-5 CLPC Series II CONTROL BOX MOUNTING	7
2-6 PNEUMATICS INSTALLATION	7
2-7 ELECTRICAL CONNECTIONS	8
2-8 MAIN POWER TO CLPC CONTROL Series II	8
2-9 TERMINAL BLOCK J1	8
2-10 TERMINAL BLOCK J2	9
2-11 TERMINAL BLOCK J3	10
2-12 TERMINAL BLOCK J4	10
2-13 TERMINAL BLOCK J5	11
2-14 ENCODER AND SENSOR WIRE COLORS	12
2-15 JUNCTION BOX TO CLPC CONTROL (Open Collector Quadrature Encoder)	12
2-16 JUNCTION BOX TO VALVES AND ENCODER (Open Collector Quadrature Encoder)	13
2-17 JUNCTION BOX TO CLPC CONTROL (Differential Line Driver Encoder)	14
2-18 JUNCTION BOX TO VALVES AND ENCODER (Differential Line Driver Encoder)	15

Section 3 START-UP and OPERATION

3-1 DESCRIPTION OF FRONT PANEL	16
3-2 INITIAL SET-UP PROCEDURE	16
A. Setting Max. Count	16
Step #1 (Set the Resolution or Ratio)	17
Step #2 (Set the Max Count)	17
B. Set Watch Dog Timer	18
C. Setting Control Mode (Dip Switch #S5)	18
D. Setting Misc. Functions (Dip Switch #S2)	18
E. Setting Misc. Functions (Dip Switch #S3)	19
F. Resetting the CLPC Series II Control	19
3-3 DESCRIPTION OF CALIBRATION METHODS	19
3-4 CALIBRATION PROCEDURE	19
3-5 SET MANUAL ADJUST	20
3-6 AUTOMATIC OPERATION	20
3-7 CLEARING A JAM	20

Section 4 TROUBLE SHOOTING

4-1 DESCRIPTION OF FRONT CONTROL PANEL	21
4-2 ERROR CODES	22
4-3 TROUBLE SHOOTING AREAS	23

Section 5 GENERAL MAINTENANCE

5-1 VISUAL CHECKS	25
5-2 ACCUMULATOR TANKS	25
5-3 GEARBOXES	25
5-4 COLLET BOLTS AND COUPLINGS	25
5-5 BELTS AND PULLEYS	25
5-6 LUBRICATION	25

Section 6 REPAIR AND REPLACEMENT

6-1 REMOVAL OF DRIVE BELTS AND SHEAVES	26
6-2 INSTALLING DRIVE BELTS AND SHEAVES	26
6-3 REMOVING <i>Posidyne</i> CLUTCH and BRAKE	27
6-4 INSTALLING <i>Posidyne</i> CLUTCH and BRAKE	27
6-5 REMOVAL OF OPEN COLLECTOR QUADRATURE ENCODER	27
6-6 REMOVAL OF QUADRATURE SENSOR AND MAGNETIC PICK-UP	27
6-7 INSTALLING OPEN COLLECTOR QUADRATURE ENCODER	28
6-8 INSTALLING QUADRATURE ENCODER AND MAGNETIC PICK-UP	28
6-9 REMOVAL AND DISASSEMBLY OF DIFFERENTIAL LINE DRIVER ENCODER	29
6-10 REASSEMBLY AND INSTALLATION OF DIFFERENTIAL LINE DRIVER ENCODER	29
6-11 REMOVAL AND INSTALLATION OF MANIFOLD MOUNTED CONTROL VALVE	30
6-12 REMOVAL AND INSTALLATION OF BRAKE RELEASE VALVE	30
6-13 REMOVAL OF STARWHEEL GEARBOXES	30
6-14 INSTALLING STARWHEEL GEARBOXES	31
6-15 STARWHEEL GEARBOX DISASSEMBLY	32
6-16 CLEANING AND INSPECTION	34
6-17 STARWHEEL GEARBOX REASSEMBLY	34
6-18 OPERATIONAL CHECKS	36
6-19 FINAL REASSEMBLY	36
6-20 REPLACING CIRCUIT BOARDS	36

Section 7 ORDERING REPAIR PARTS

7-1 GENERAL INFORMATION	37
7-2 FACTORY RE-BUILD SERVICE	37
7-3 DRIVE MOTORS	37
7-4 ORDERING REPAIR PARTS	37

Exploded View Drawings

AUTO-CATCHER ASSEMBLY (Figure 7.1)	39
PNEUMATIC ACCUMULATOR TANK ASS'Y. (Figure 7.2)	41
OPEN COLLECTOR QUADRATURE ENCODER (Figure 7.3)	43
DIFFERENTIAL LINE DRIVER ENCODER (Figure 7.4)	43
STARWHEEL GEARBOX ASSEMBLY (Figure 7.5)	45
2.5 <i>Posidyne</i> CLUTCH and BRAKE	
FAN COOLING (Figure 7.6)	46
2.5 <i>Posidyne</i> CLUTCH and BRAKE UNIT (Figure 7.7)	47
JUNCTION BOX (Figure 7.8)	48
CLPC Series II CONTROL (Figure 7.9)	49
CPU BOARD LAYOUT	50
POWER SUPPLY BOARD LAYOUT	51
CLPC II REVISION HISTORY	52

Section 1

SYSTEM DESCRIPTION

IMPORTANT:
THIS MANUAL ONLY APPLIES TO AUTO CATCHER DRIVE ASSEMBLIES WITH CLPC Series II CONTROL SYSTEMS WITH SOFTWARE VERSION OF 2.0.1 OR HIGHER.

1-1 GENERAL DESCRIPTION

The Force Control Autocatcher Drive Assembly is used to index the Starwheels of a mechanical shingle catcher and /or stacker. On 4-bladed starwheels the drive, initiated by a signal from the PLC, will index the starwheels 90° quickly and accurately. Other degrees of rotation are possible through internal adjustments.

The drive package is self contained which includes:

1. Drive Motor with Slide Adjust Base.
2. Input Belt Drive
3. *Posidyne* Clutch/Brake Unit with manifold mounted control valve.
4. Positioning Encoder Assembly mounted on the *Posidyne* Clutch and Brake Unit.
5. Output Belt Drive.
6. Starwheel Gearboxes with a ratio of 4:1 with a Zero Backlash Coupling.
7. Pneumatic Accumulator Sub-Assembly.
8. Brake Release Valve.
9. CLPC™ Series II Electronic Closed Loop Positioning Control and Junction Box.

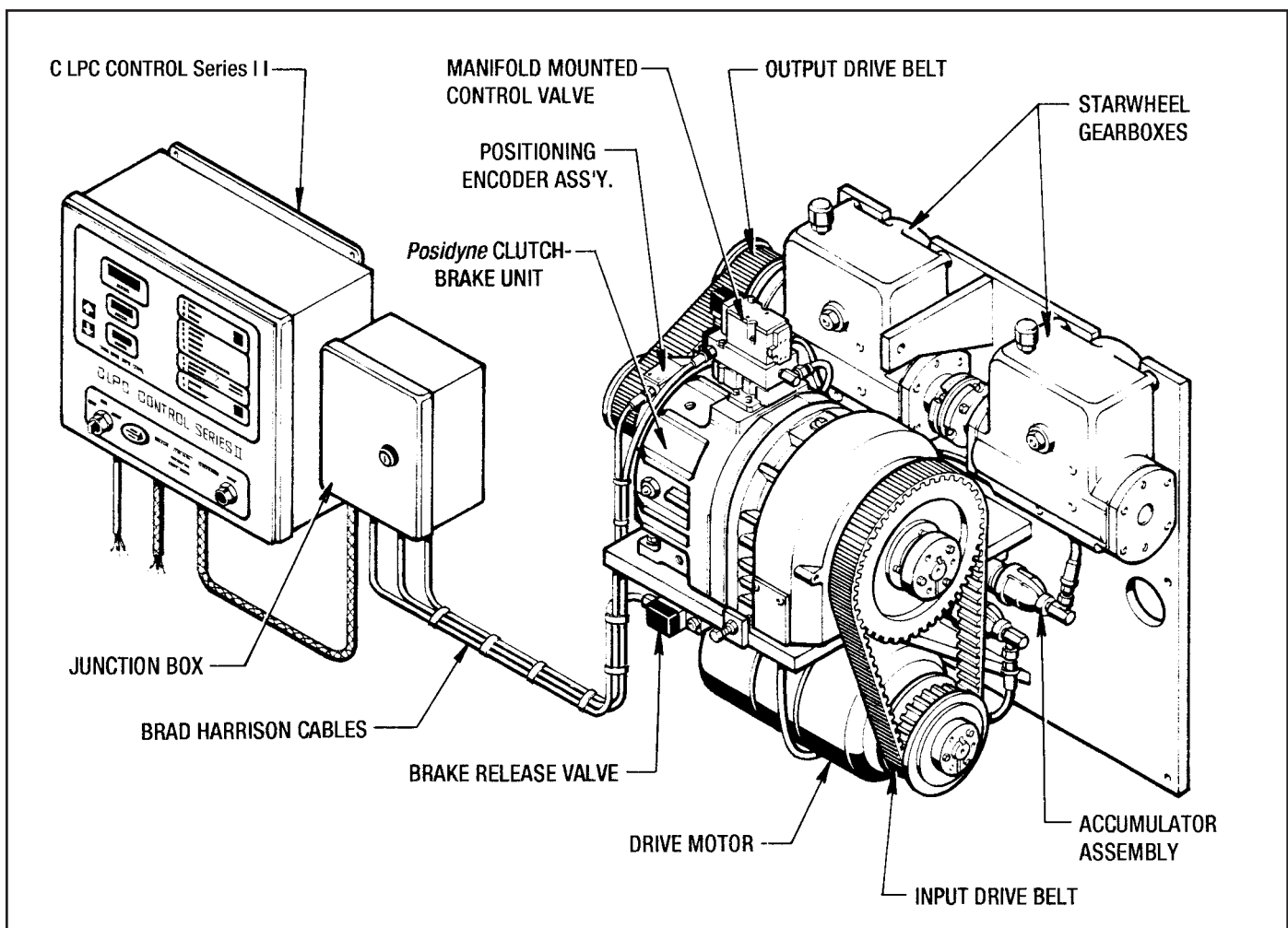

Figure 1.1 - Auto Catcher Assembly

1-2 Posidyne CLUTCH / BRAKE UNIT

The heart of the drive is the 2.5 *Posidyne* Clutch/Brake. The *Posidyne* Clutch/Brake is a multiple disc, Oil Shear clutch/brake which uses automatic transmission fluid to provide both cooling and lubrication of the friction surfaces. A patented fluid circulation system is used to maintain this fluid film on the friction surfaces at all times. (See Figure 1.2) By lubricating and cooling the friction surfaces, service life is substantially increased and accuracy improved. The totally enclosed housing also reduces problems associated with dust, dirt and moisture.

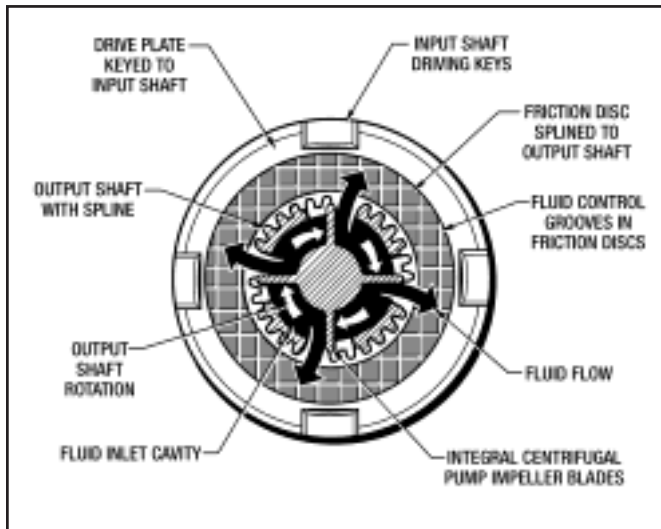

Figure 1.2 - The Oil Shear System

The *Posidyne* Clutch/Brake has a centrally located air actuated piston which will engage either the clutch or brake depending on valve position. Air pressure determines the torque that is transmitted through the stack. Air is routed to the clutch or brake through a valve assembly, manifold mounted on the top of the *Posidyne* Clutch/Brake. (See Section 1 in the *Posidyne* manual for cross section of the drive).

NOTE:

For easy removal, the manifold mounted valve, brake release valve and the Positioning Encoders are wired to a small junction box using Brad Harrison quick disconnect cables. Each connector uses a different number of pins so that they cannot be installed in the wrong location.

When at rest the *Posidyne* Clutch/Brake will have the brake applied. In order to move the starwheels by hand to clear a jam the brake must be released. This is done through the Brake Release Valve mounted on the *Posidyne* base. It is normally connected through the control so that it exhausts the brake when the "HOA" switch is turned to "OFF".

Torque required to turn the star wheel blades by hand may be further reduced by manually shifting the main control

valve on top of the *Posidyne*. This must only be done when the motor is turned Off, locked out and not rotating.

1-3 POSITIONING ENCODER ASSEMBLY

There are two types of Positioning Encoders available and they are both mounted to the *Posidyne* output shaft.

The first type is an Open Collector Quadrature Encoder which contains a dual (60 tooth/single tooth) pulse gear, quadrature sensor for the A and B channel and a magnetic pick-up for the (Home) Z channel.

The second type is a Differential Line Driver Encoder which uses a (120 pulse/single pulse) optical disc and (3) photo sensors that generates a 120 pulse quadrature pulse train (A and B channels) and one Home pulse (Z channel). A complimentary pulse for each channel is sent to the CLPC Control which reduces the possibility of "Noise" being received and in-turn allows for longer wire runs between the Encoder and the CLPC Control.

Each revolution of the *Posidyne* output shaft is one cycle or 120 pulses. The CLPC™ Control Series II uses this count to index the *Posidyne* Clutch/ Brake exactly one revolution. Through the 4:1 Starwheel Gearboxes this relates to 90° rotation of the Starwheels. The Quadrature Encoder will count pulses in either direction. This means as long as the control is powered up it will not lose position even while manually turning the Starwheels to clear a jam.

On original start-up the control will have to be calibrated to relocate the Home position. This process takes two (2) indexes of the drive. The control will index one (1) time to determine where the Home position is located and how many pulses are required to stop the drive. The next index will set a trigger point to actuate the control valve so that the drive will stop in position.

1-4 CLPC™ CLOSED LOOP POSITIONING CONTROL Series II

The CLPC™ Series II is an electronic, error correcting, closed loop positioning control used to operate the *Posidyne* Clutch/Brake in a positioning application. It is designed as a stand alone interface control between the main PLC, or other machine control and the *Posidyne* Clutch/Brake. Upon a signal from the machine control center it will start the drive (engage the clutch), index and stop at a precise, pre-determined position, unaffected by air pressure, speed and load change, PLC scan time or any changes in the dynamics of the machine. Major changes may require several indexes before a total correction is made.

The CLPC™ Control Series II processes a signal from the PLC to index. During the Calibration Cycle the control determines where the trigger point for the brake was to occur in order to stop in home position. When it sees the

trigger point count from the encoder it engages the brake to stop in position. The actual count vs. the required stop position is processed and if necessary the trigger point is adjusted to correct this position. In this way the control is continually correcting any error in position.

The stop position of the starwheel can be manually adjusted using the CLPC™ Control Series II. The manual adjust increment and decrement button will move the trigger point to adjust the stopping position up to plus or minus 1/3 of the index. This can be used to adjust for different products or installation position of the starwheels. Once set the manual adjust offset is stored in an EEPROM and will be maintained even if the power is turned off to the control. It is used when the unit is re-calibrated.

Start Cycle (PLC Interface)

The start cycle signal required by the **CLPC Series II Control** is a short pulse of 100 milliseconds in duration which can be furnished from a PLC output or other source. DC is recommended for the most consistent operation. The required signal can be AC or DC and must be:

1. 90 to 140 VAC (typ. 115 VAC), cold contact, with 6 to 10 milliamps input current and 2.5 milliamps drop out current.
2. 10 to 30 VDC (**Recommended**).

1-5 RIGHT ANGLE GEAR BOXES

Two (2) Right Angle, 4:1 Gear Boxes are used to drive the Starwheels. A 1:1 Poly Chain Belt drives the input gearbox which is coupled to the other gearbox. A collet arrangement is used to connect the gearboxes to the starwheel shafts. (See Figure 1.3) The collet is a tapered shell bored

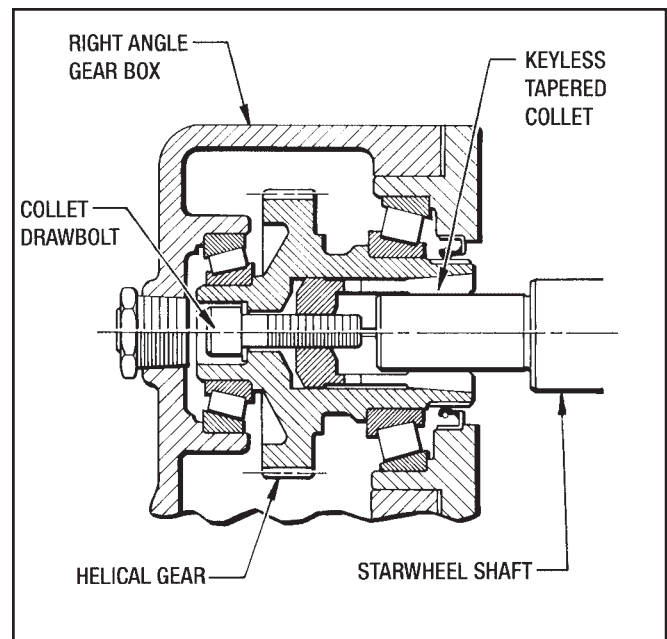

Figure 1.3 - Collet Arrangement

to a standard shaft diameter and fits in the tapered bore of the helical gear. When drawn tight into the gear, using the drawbolt, it clamps onto the shaft creating a solid connection without a key. The Starwheel can be rotated in any position. The collet connection to the gearbox eliminates the need for a pillow block bearing or coupling to connect to the Starwheel.

1-6 PNEUMATICS

The air supply system consists of (2) accumulator tanks furnished with separate regulators and water drains, a manifold mounted valve and brake release valve. The incoming air supply should be maintained at a minimum of 80 PSIG of clean dry air. With this application the, *Posidyne* Clutch/Brake operates best at a pressure of 35 PSIG for both the Clutch and Brake. One accumulator is for the clutch, the other for the brake. From the accumulator the clutch air is connected directly to the manifold mounted valve. From the accumulator, the brake air is connected to a normally closed brake release valve. When the brake release valve is de-energized, the brake air pressure is exhausted to allow the Starwheels to be rotated manually. (See Figure 1.4)

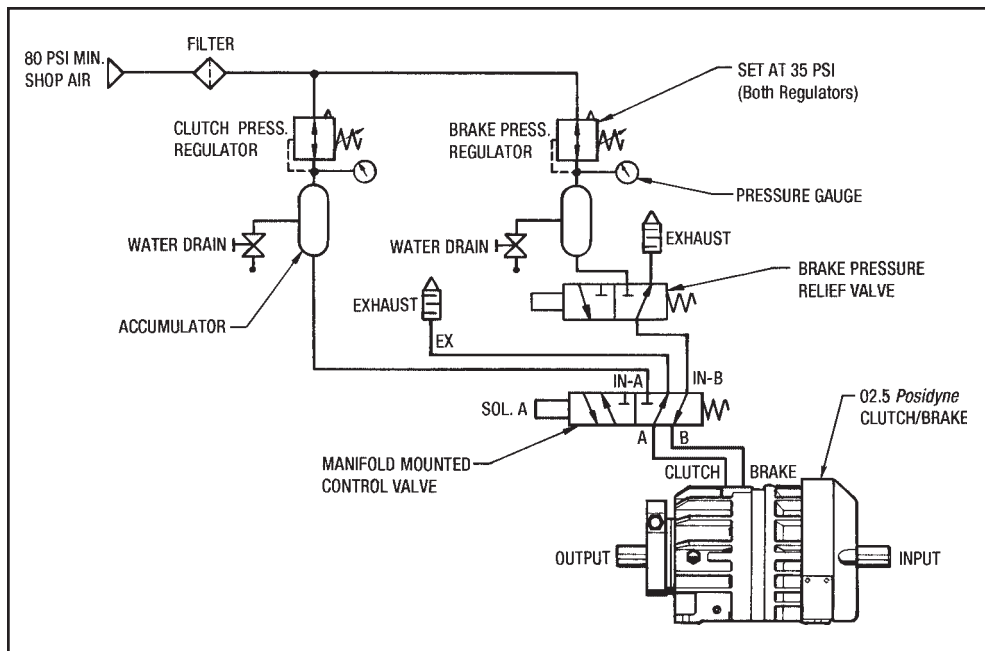

Figure 1.4 - Pneumatic Diagram

Section 2 INSTALLATION

The Force Control Autocatcher Drive Assembly comes complete on a base plate leaving only the Junction Box and the CLPC Control Box to install separately.

2-1 DRIVE UNIT INSTALLATION

(See Figure 2.1)

1. Verify that the starwheel shaft is the required length to extend into the collet 1.00" to 1.25".
2. Check to see if there is enough room at the other end of the catcher to slide the starwheel shaft completely out of the collet.
3. Establish the position of the starwheels before removing any existing drive components. The center distance between starwheels is fixed on the Force Control Drive Assembly. Check this center distance before installation.

IMPORTANT

It is critical to determine the height and angle (if not horizontal) of the existing starwheels.

4. Remove the old equipment to be replaced and clean the frame for mounting of the Force Control base. Remember that the pillow block normally used on the drive end will be removed. The shaft is supported in the collet of the gearbox.
5. Position the drive assembly in line with the starwheel shafts. The bearing at the other end of the starwheel should be floated in to align with the gearbox. (See Figure 2.1 below)

IMPORTANT

The alignment of the starwheel shaft with the collet is critical. Alignment must be in both planes as there is a rigid connection between the starwheel shaft and the gearbox.

6. With the complete assembly in place, weld the mounting bars to the existing catcher frame. The complete drive unit base can now be removed by unbolting it from the mounting bars.

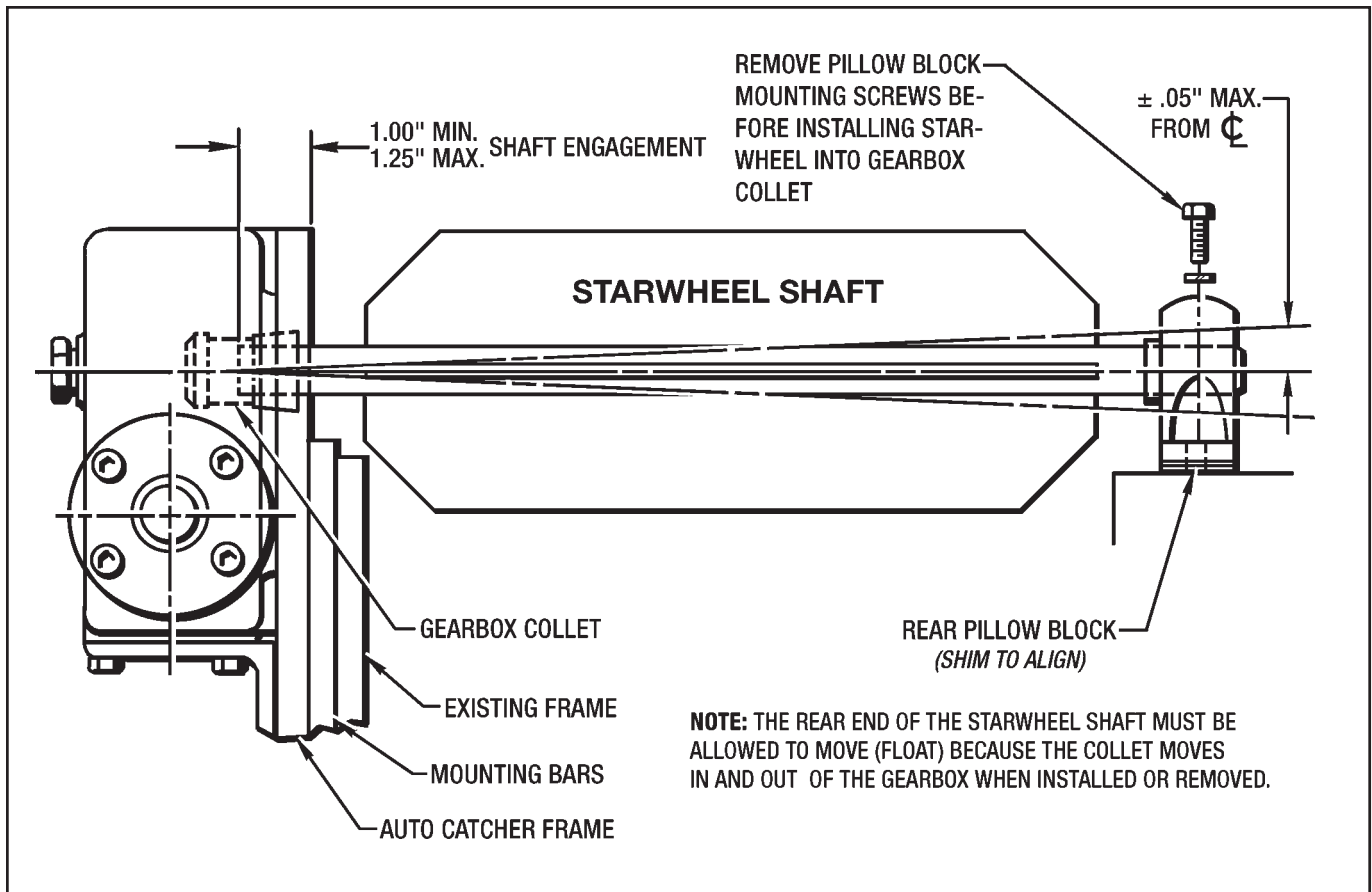

Figure 2.1 - Drive Unit Installation

2-2 INSTALLATION OF THE STARWHEEL SHAFT INTO THE GEARBOX COLLET

(See Figures 2.2 and 7.4)

1. Remove the 1/4" Pipe Plug (#830) in the back of the Gearbox (#800) opposite the starwheel location.
IMPORTANT: Do not remove the Reducer Bushing (#836).
2. Remove Rear Pillow Block Mounting Screws.
3. Loosen the Collet Bolt (#843) using a modified 3/8" allen wrench as shown in Figure 2.2. Loosen enough so that the collet extends beyond the bearing retainer when pushing on the collet bolt.
4. Mark the starwheel shaft in two locations. 1" and 1-1/4" from the end of the starwheel shaft.
5. Install the starwheel shaft into the Collet (#823). The end of the Collet should be between the two marks on the shaft end. Push in on the collet bolt to keep the collet loose. **IMPORTANT: Be careful not to install the starwheel shaft in too far because the collet will not tighten properly.**
6. Position the starwheel blades properly and tighten the Collet Bolt (#843) to **85 Ft. Lbs.** with a Torque Wrench. **IMPORTANT: This is critical to avoid the Starwheel from slipping in the collet. Do not overtighten.**

7. Replace the Pipe Plug (#830) back into the gearbox housing.
8. Reposition and align the Rear Pillow Block as shown in Figures 2.1 and 2.2.

2-3 REMOVAL OF THE STARWHEEL SHAFT FROM THE GEARBOX COLLET

(See Figure 2.2)

1. Remove the Pipe Plug (#830) opposite the starwheel location. **IMPORTANT: Do not remove the Reducer Bushing (#836).**
2. Remove the Rear Pillow Block Mounting Screws as shown in Figure 2.2.
3. Using a modified 3/8" Allen Wrench, loosen the Collet Bolt (#843). Continue to turn the Collet Bolt until resistance is felt. Two more turns should loosen the collet and allow removal of the starwheel shaft.

2-4 JUNCTION BOX MOUNTING

The Junction Box needs to be mounted within reach of the three Brad Harrison cables from the Drive Assembly. It can be mounted on the drive base or other frame work using the (4) mounting holes in the rear of the box. (See Figure 2.3 for mounting hole dimensions.)

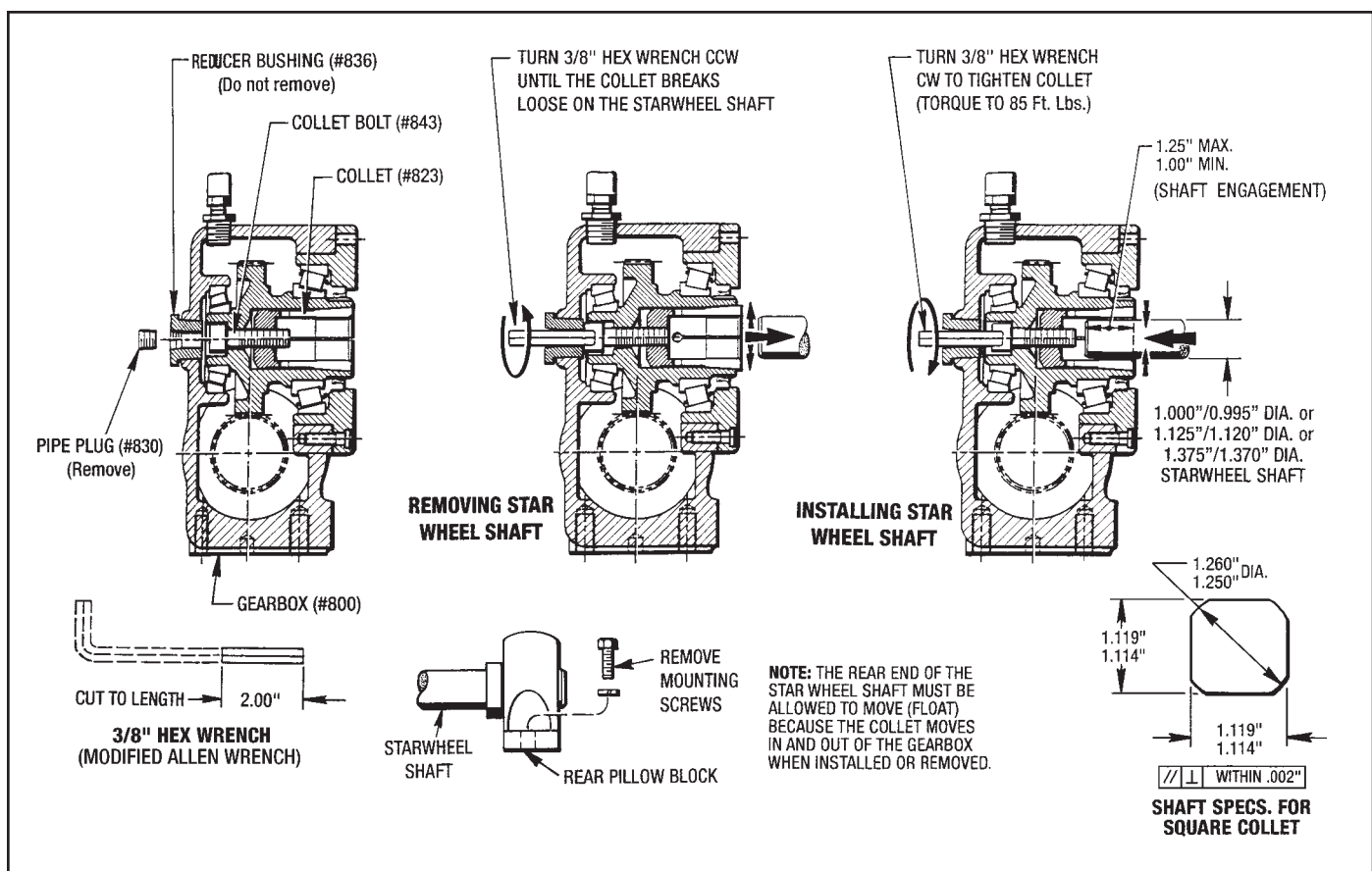

Figure 2.2 - Installing Starwheel into the Gearbox Collet

2-5 CLPC Series II CONTROL BOX MOUNTING

The CLPC Series II Control should be mounted within 50 ft. of the drive, convenient to the operator as a Remote Operator's Station. There are no additional controls to be mounted on the main electrical panel. Mounting should be on a solid structure away from heat and vibration using the mounting holes provided as shown in *Figure 2.3*. (See **Section 2.7 Electrical Connections** for additional wiring information.)

2-6 PNEUMATICS INSTALLATION

(See *Figures 1.4 and 7.2*)

Clean, dry, compressed air is required to operate the Clutch/Brake Unit. It should be a minimum of 80 PSIG supplied to both Regulators. 3/4" O.D. pipe or 1/2" I.D. tubing is recommended. Lubricated air is not required for the *Posidyne* Clutch/Brake, however other equipment may require lubrication. All other piping and valves are factory installed on the drive. Set both the Clutch and Brake Regulators on the Accumulators to 35 PSIG (Factory setting) on initial setup.

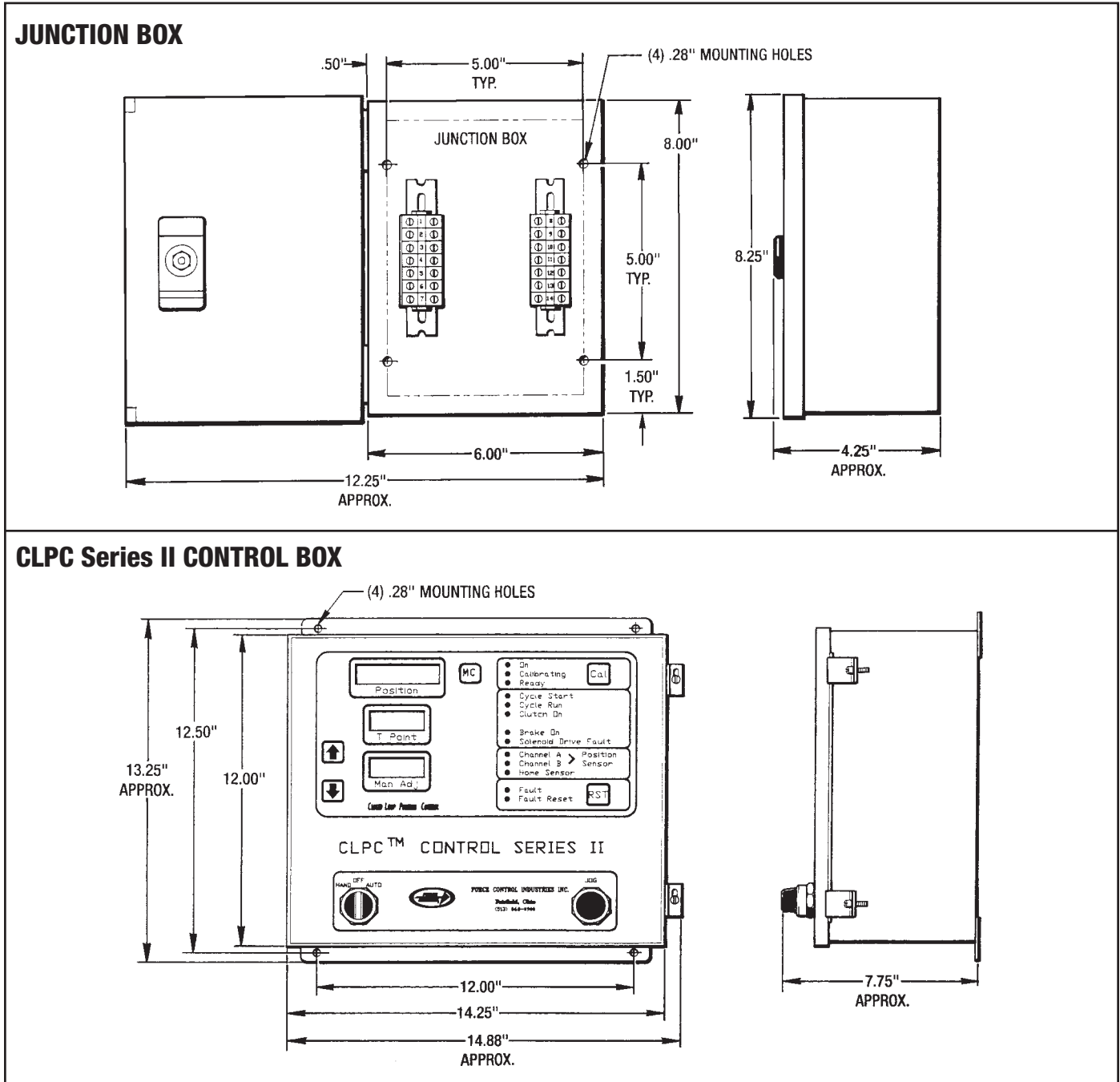

Figure 2.3 - CLPC Control and Junction Box Dimensions

2-7 ELECTRICAL CONNECTIONS

There are numerous wiring connections to be made, some of which will be completed when the system is received and others that will need to be completed in the field. Also note that there may be optional items which will not be used in all applications.

IMPORTANT: It is critical that the correct wiring type and wiring paths be followed for maximum performance and minimum of electrical noise interruptions.

Electrical noise is any electrical disturbance which can cause erroneous operation of the control. It is often caused by transients generated by load switching where line to ground spikes are generated. Starting of motors, actuating solenoids and certain types of motors such as regenerative and synchronous motors can all cause transients.

The **CLPC Series II Control** has a high degree of noise immunity built in, however noise can cause false firing of low voltage encoders. Therefore it is important to follow the following recommended wiring procedures on the next page.

A. Type of Wiring for Encoder Connections

The wire for the encoders should be individually shielded, twisted pair tray cable with minimum 22 AWG copper stranded conductors. Pairs which can be routed together are shown on the wiring diagrams. The wire should be as short as possible. **Excess wire should be cut off, not coiled up. The cable shields should be grounded only at the DC negative.** (See wiring diagram for proper terminals on the CLPC Series II Control.)

B. Wire Paths and Max. Wire Lengths

CAUTION: Avoid running high voltage and low voltage lines together.

All high speed, low voltage input cables from encoders, home switch, etc. must be routed away from high voltage cables, AC power lines or other wiring carrying rapid switching transients. If a long run is necessary the encoder wiring should be run in a dedicated conduit for that purpose only.

With an Open Collector Encoder the max. length is 250 Ft.

With a Differential Line Driver Encoder the max. wire length is 1000 Ft., also the Pneumatic Control Valve can be a max. of 1000 Ft. away from the control.

2-8 MAIN POWER TO CLPC Series II CONTROL

(See Figure 2.4)

The main power supply to the CLPC Series II Control should be 115 VAC or 230 VAC, 150 Watts. The Input Power Selector must be set to match the input voltage (Default setting is 115 VAC). The selector switch is located in the upper left hand corner of the internal power supply board.

The power should be clean and of good quality similar to that used for other electronic devices. Should the line power be "dirty" with high voltage spikes and transients a dedicated isolation transformer should be used.

2-9 TERMINAL BLOCK J1 (Main Power Supply to CLPC Series II Control)

(See Figures 2.4 and 2.5)

115 VAC to Terminal Block J1 Terminal #1
 Neutral to Terminal Block J1 Terminal #2
 Earth Ground to Terminal Block J1 Terminal #3

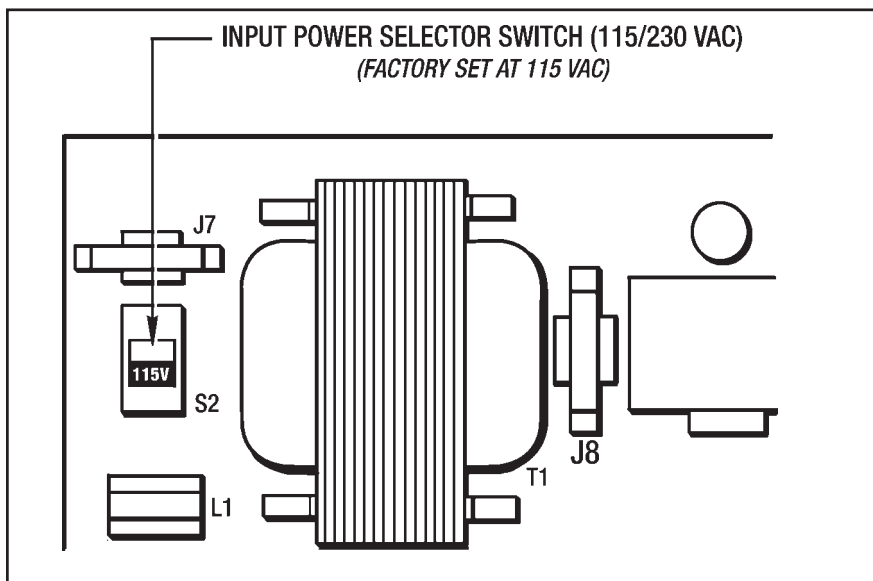

Figure 2.4 - Input Power Selector Switch

2-11 TERMINAL BLOCK J3 (CLPC Control to Actuation Valve)

(See Figure 2.7 and Wiring Diagrams on Pages 11, 14, 36 & 37)

TERMINAL BLOCK J3

(DC Power, DC Ground and DC Outputs)

Terminal #1	Misc. power +8 Volts DC unregulated
Terminal #2	Misc. power +8 Volts DC unregulated
Terminal #3	Misc. DC Ground
Terminal #4	Misc. DC Ground
Terminal #5	Misc. Pwr. +24 VDC, unregulated, 1 Amp max.
Terminal #6	Clutch/Brake coil over ride
Terminal #7	Not Used
Terminal #8	Not Used
Terminal #9	Clutch #1 actuation valve, switched
Terminal #10	Clutch #1 actuation valve, +24 Volts DC
Terminal #11	Not Used
Terminal #12	Not Used

NOTES:

1. Terminals #1 and #2 together must not exceed 1 Amp.
2. Terminals #8, #10 and #12 together must not exceed 3 Amps.
3. 24 VDC power is supplied to coils at all times. Ground leg is switched by CLPC.

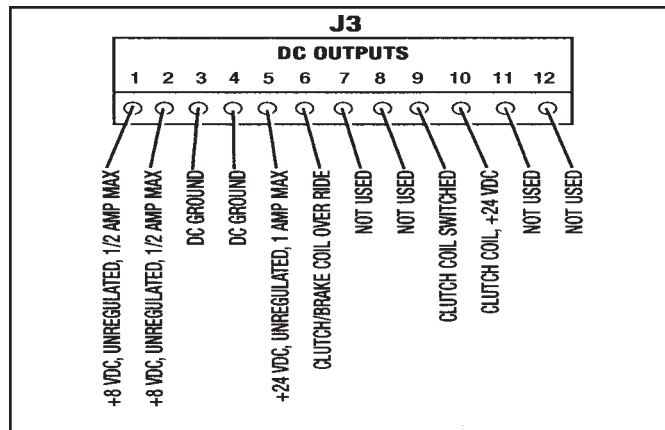

Figure 2.7 - Junction Block J3

2-12 TERMINAL BLOCK J4 (Inputs from external source to CLPC Series II Control)

(See Figure 2.8)

Inputs - Solid state relays are used 115 VAC or 7 to 60 VDC relays are available, cold contacts, 10 mA max. input current, 2.5 mA drop out current, 3.0 mA allowable for no output. **DC Start Cycle Input Signal is recommended for the most consistent operation.**

NOTE: For AC inputs that are driven by a device that has leakage current (PLC) a resistor must be used across the terminals to bleed off current to avoid false triggering. The

resistor size is dependent upon the leakage current of the PLC output. If the leakage current is no more than 50 mA use a 2500 ohm, 10 watt resistor. If less than 12 mA use a 10,000 ohm, 2 watt resistor. (See Figure 2.8)

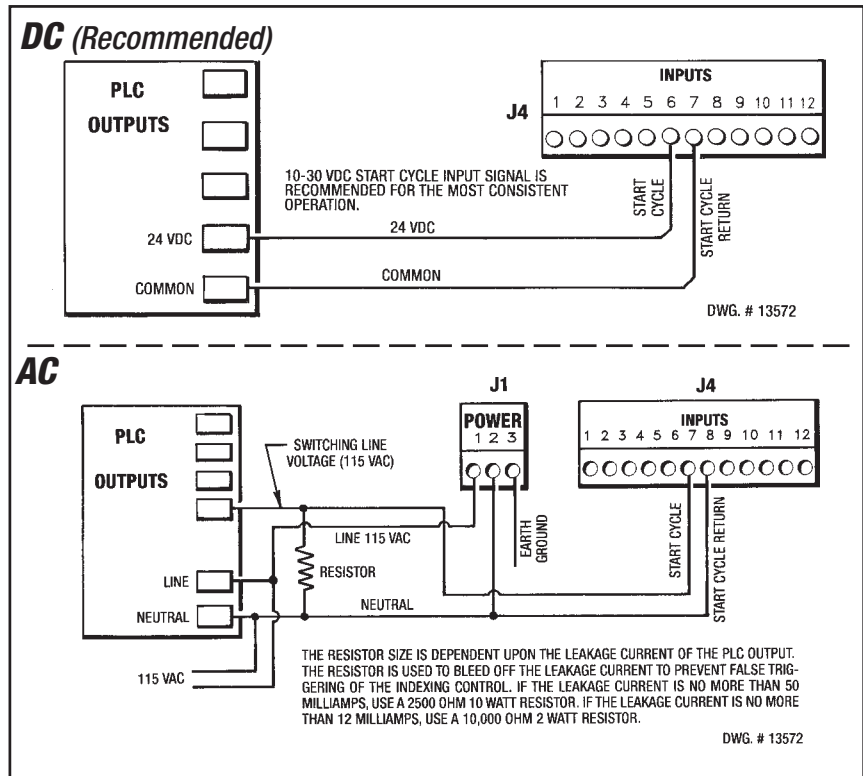

Figure 2.8 - Terminal Block J4 and PLC to CLPC Schematic

TERMINAL BLOCK J4

Terminal #1	Misc. Fault Input #1. Sensor can be N.O. or N.C. Use Jumper on Switch #JP12 to set. (See Note 1) It can be used as Over Temperature Sensor. (Thermal cut-out switch must be installed in Posidyne Clutch/Brake.)
Terminal #2	Misc. Fault Input #1 Return.
Terminal #3	Misc. Fault Input #2. Sensor can be N.O. or N.C. Use Jumper on Switch #JP13 to set. (See Note 1). It can be used as a low pressure sensor. (Pressure Transducer must be installed in the air line upstream from air valve.)
Terminal #4	Misc. Fault Input #2 Return.
Terminal #5	Interlock, Clutch/Brake +24 VDC
Terminal #6	Interlock Return
Terminal #7	Start Cycle - Initiates an index (+ when using DC)
Terminal #8	Start Cycle Return. (- when using DC)
Terminal #9	Calibrate Request. (Initiates Calibration remotely)
Terminal #10	Calibrate Request Return
Terminal #11	Fault Reset - Resets Faults remotely. Resets all faults except solenoid fault.
Terminal #12	Fault Reset Return

- NOTES:**
1. On Jumper JP12 & JP13 the middle and right pins are for N.O., the middle and left pins are for N.C.
 2. Terminals 1 thru 6 and 9 thru 12 are optional and not required for the control to operate properly.

2-14 ENCODER AND SENSOR WIRE COLORS

WIRE	OPEN COLLECTOR ENCODER			DIFFERENTIAL LINE DRIVER ENCODER INCREMENTAL ENCODER AND HOME SENSOR
	QUAD. SENSOR		HOME SENSOR	
	(Old)	(New)	Internal	
Power	Red	Red	Red	Red #1
Ground	Black	Black	Black	Black #1
A	White & Orange	White & Green	---	Black #4
A'	---	---	---	Red #4
B	White & Purple	White & Yellow	---	Black #3
B'	---	---	---	Red #3
Z	---	---	White	Black #2
Z'	---	---	---	Red #2

2-15 OPTIONAL JUNCTION BOX TO CLPC CONTROL (With Open Collector Quadrature Encoder)

JUNCTION BOX TERMINAL	FUNCTION	CONNECT TO:	JUNCTION BOX TERMINAL	FUNCTION	CONNECT TO:
1	Clutch Coil, +24 VDC	J3, #10	8	Encoder Channel Z (Home)	J5, #2
2	Clutch Coil, Switched	J3, #9	9	Encoder Power	J5, #8
3	E Ground	---	10	Encoder DC Ground	J5, #7
4	Not Used	---	11	Encoder Channel A or B	*J5, #4 or #6
5	Brake Pr. Relief Valve	J2, #2	12	Encoder Channel A or B	*J5, #4 or #6
6	Brake Pr. Relief Valve	J1, #2	13	Not Used	---
7	E Ground	---	14	Not Used	---

* See Note Below

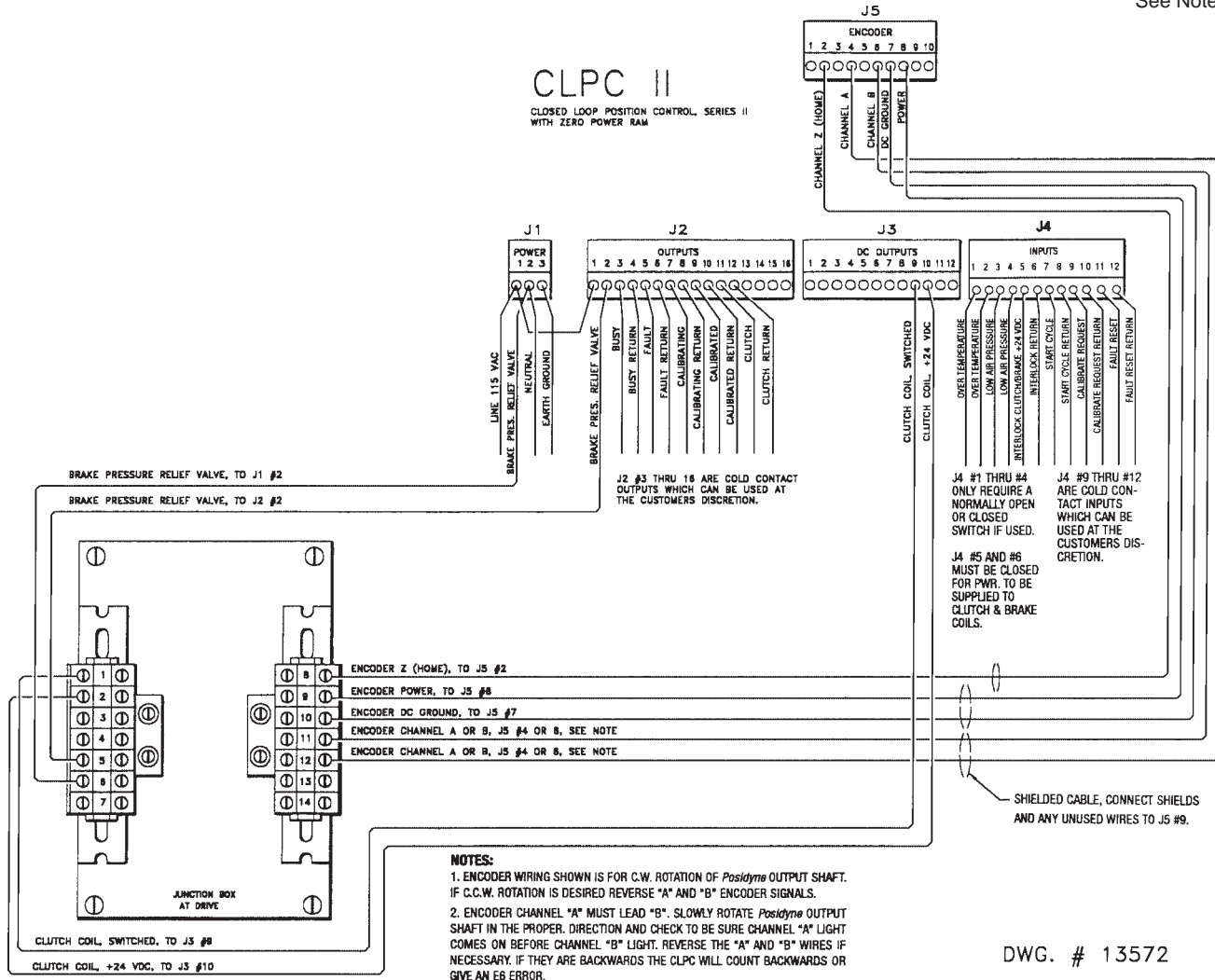

DWG. # 13572

Figure 2.11 - Wiring Diagram - Junction Box to CLPC Control

2-16 JUNCTION BOX TO ACTUATION VALVES AND POSITION ENCODER (Open Collector Quadrature Encoder)

JUNCTION BOX TERMINAL	FUNCTION	WIRE COLOR	CONNECTOR PIN NUMBER
1	Clutch Coil, +24 VDC	White	2
2	Clutch Coil, Switched	Black	1
3	E Ground	Green	4
4	Not Used	---	---
5	Brake Pressure Relief Valve (L2)	White	3
6	Brake Pressure Relief Valve (L1)	Black	2
7	E Ground	Green	1
8	Encoder Channel Z (Home) Sensor	White	1
9	Encoder Power	Red	2
10	Encoder DC Ground	Black	5
11	Encoder Channel A or B	Green	3
12	Encoder Channel A or B	Orange	4
13	Not Used	---	---
14	Not Used	---	---

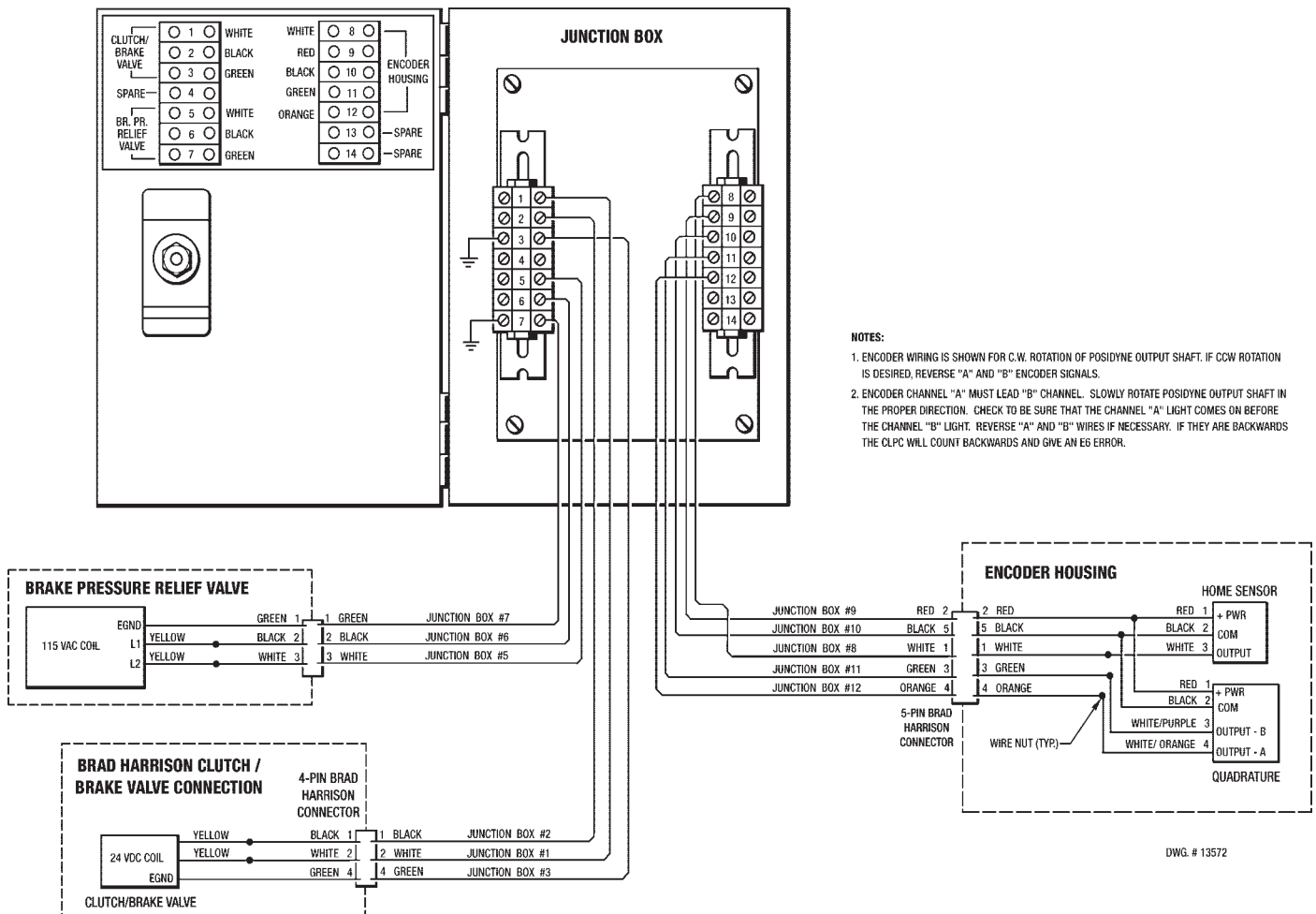

Figure 2.12 - Wiring Diagram - Junction Box to Actuation Valves and Position Encoder (Open Collector Quadrature Encoder)

2-17 JUNCTION BOX TO CLPC CONTROL (With Differential Line Driver Encoder)

JUNCTION BOX TERMINAL	FUNCTION	CONNECT TO CLPC TERMINAL	JUNCTION BOX TERMINAL	FUNCTION	CONNECT TO CLPC TERMINAL
1	Clutch Coil, +24 VDC	J3, #10	9	Encoder Channel Z	J5, #2
2	Clutch Coil, Switched	J3, #9	*10	Encoder Channel A' or B' (Compliment)	J5, #3 or #5
3	E Ground	---	*11	Encoder Channel A or B	J5, #4 or #6
4	Not Used	---	*12	Encoder Channel A' or B' (Compliment)	J5, #3 or #5
5	Brake Pr. Relief Valve	J2, #2	*13	Encoder Channel A or B	J5, #4 or #6
6	Brake Pr. Relief Valve	J1, #2	14	Encoder & Home Sensor DC Grd.	J5, #7
7	E Ground	---	15	Encoder & Home Sensor Power	J5, #8
8	Encoder Channel Z' (Home, Compliment)	J5, #1	---	Encoder Cable Shields	J5, #9

* See Note Below

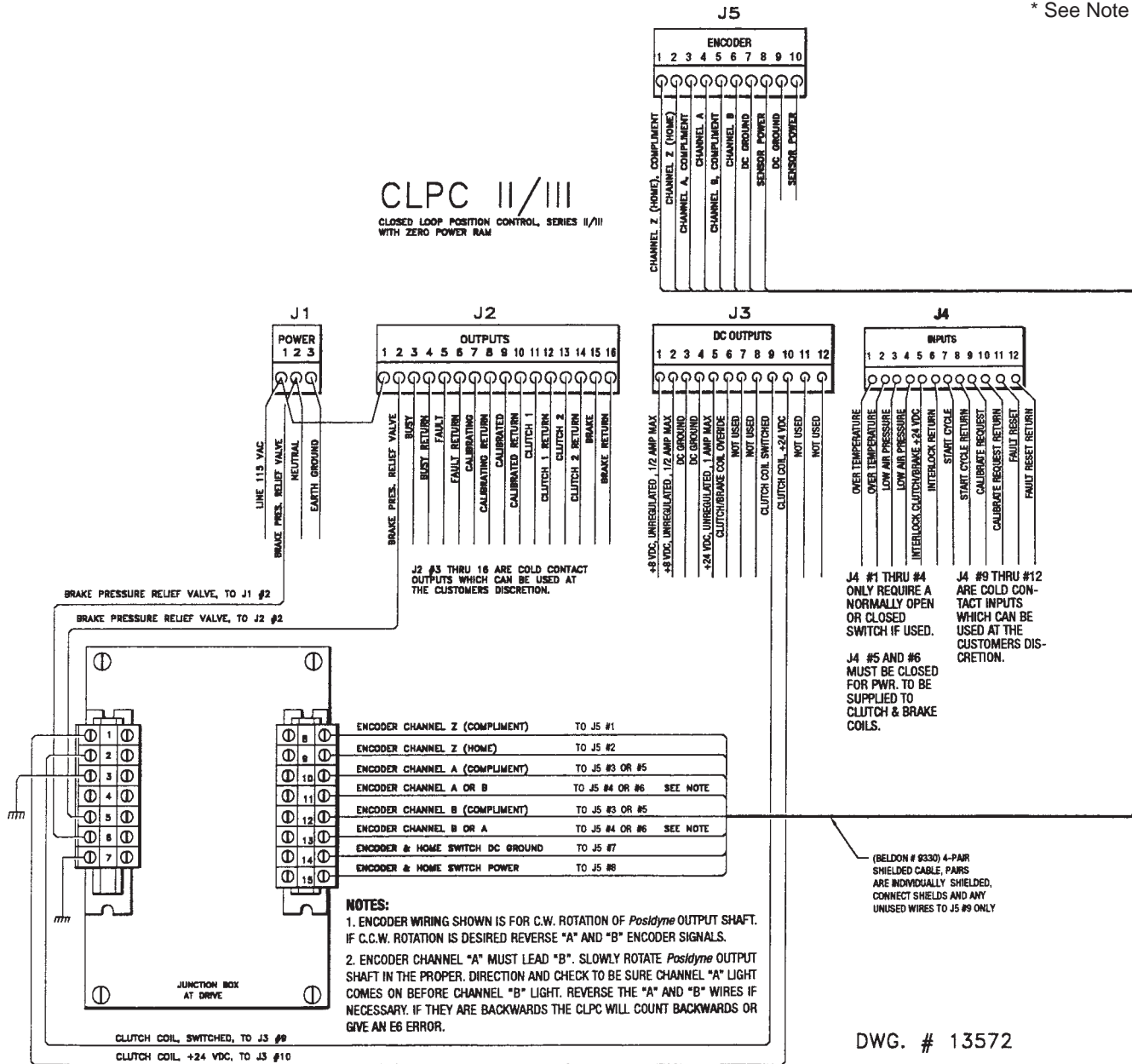

Figure 2.13 - Wiring Diagram - Junction Box to CLPC Control (With Differential Line Driver Encoder)

2-18 JUNCTION BOX TO ACTUATION VALVES AND OPTICAL ENCODER (Differential Line Driver Encoder)

JUNCTION BOX TERMINAL	FUNCTION	WIRE COLOR	CONNECT TO TERMINAL
1	Clutch Coil, +24 VDC	White	2
2	Clutch Coil, Switched	Black	1
3	E Ground	Green	4
4	Not Used	---	---
5	Brake Pr. Relief Valve (L2)	White	3
6	Brake Pr. Relief Valve (L1)	Black	2
7	E Ground	Green	4
8	Encoder Channel Z'	Red 2	Z'
9	Encoder Channel Z (Home) Sensor	Black 2	Z
10	Encoder Channel A'	Red 4	A'
11	Encoder Channel A	Black 4	A
12	Encoder Channel B'	Red 3	B'
13	Encoder Channel B	Black 3	B
14	DC Ground	Red 1	Ret
15	Encoder Power	Black 1	Pwr

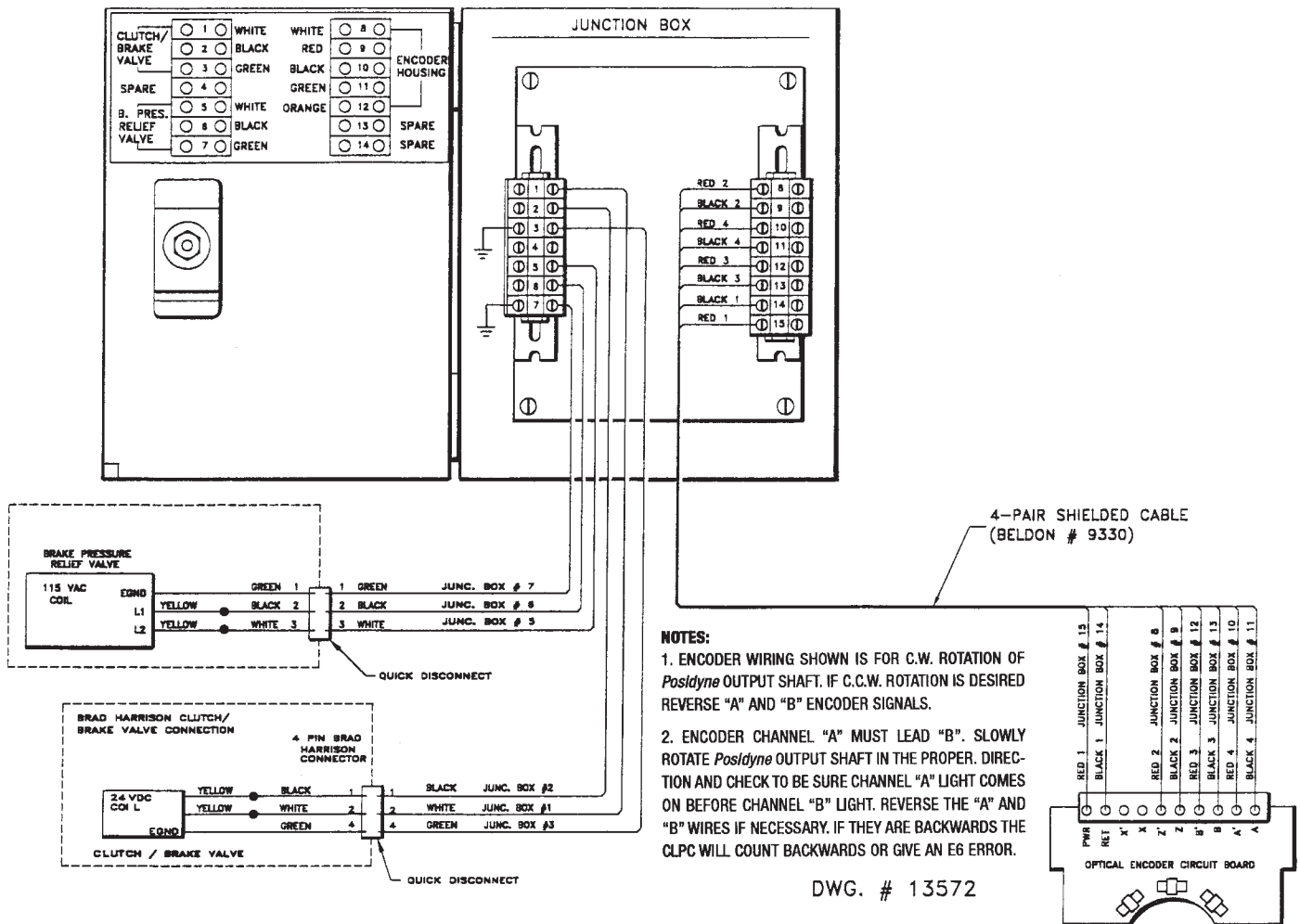

Figure 2.14 - Wiring Diagram - Junction Box to Actuation Valves and Differential Line Driver Encoder

Section 3

START-UP and OPERATION

3-1 DESCRIPTION OF FRONT CONTROL PANEL

(See Figure 3.1)

A. Displays

1. **Position** - Shows relative position of the **Encoder Counter**. It should theoretically stop at 0. Due to slight variations in stopping position and depending on resolution, it may read 1 or 2 if over and 119 or 118 if under if the Max Count is set to 120.
2. **Trigger Point** - This is the count at which the brake is engaged before the desired stopping point. It is continually adjusted by the Automatic Closed Loop Control. When the Fault light is on an Error Code is indicated in the Trigger Point Display. The installed Software Version will momentarily be displayed when the control is first turned on.
3. **Manual Adjust** - Displays the manual adjustment to the Stopping Point. This adjustment is the number of pulses from the Home (Z Channel) marker.

B. Indicator Lights

1. **On** - Indicates that **Power is ON** and the Selector Switch is in **Hand** or **Auto**.
2. **Calibrate** - Indicates the Control is in the **Calibrating Mode**.
3. **Ready** - Indicates the Control is **Calibrated and Ready for Operation**.
4. **Cycle Start** - Lights when the control gets a Signal to **Start the Cycle**, either from the Jog Switch or Cycle Start Input Relay.
5. **Cycle Run** - Lights when a **Cycle** is in operation.
6. **Clutch On** - Indicates when the **Clutch Solenoid** is energized.
7. **Brake On** - Indicates when the Clutch Solenoid is de-energized and the **Brake is On**.
8. **Solenoid Driver Fault** - Indicates that there is a Short or Overload in the Valve Solenoid or Wiring.
9. **Channel A** - Indicates a pulse from "A" Channel of the Quadrature Encoder.
10. **Channel B** - Indicates a pulse from "B" Channel of the Quadrature Encoder.
11. **Home Sensor** - Indicates a pulse from the **Home Sensor** (Z Channel).
12. **Fault** - Indicates a Control Fault. (An Error Code will be displayed in the Trigger Point Display.)
13. **Fault Reset** - Lights when the control sets a Fault Reset signal, either from the RST Button or fault reset input relay.

C. Switches

1. **HAND/OFF/AUTO** - Switch used to select "Hand", "Off" or "Auto" Mode.
2. **JOG** - Used to manually index the control when the selector is in "Hand" Mode.

D. Buttons

1. **CAL** - Used to initiate the **Calibrate Cycle**.
2. **RST** - **Resets the Control** after a Control Fault.
3. **Manual Adjust "UP"** - Adjusts the **Trigger Point** in a Positive Direction.
4. **Manual Adjust "DOWN"** - Adjusts the **Trigger Point** in a Negative Direction
5. **MC-(Max Count)** - Used to set the Total Number of Pulses to complete a Single Index or Cycle.

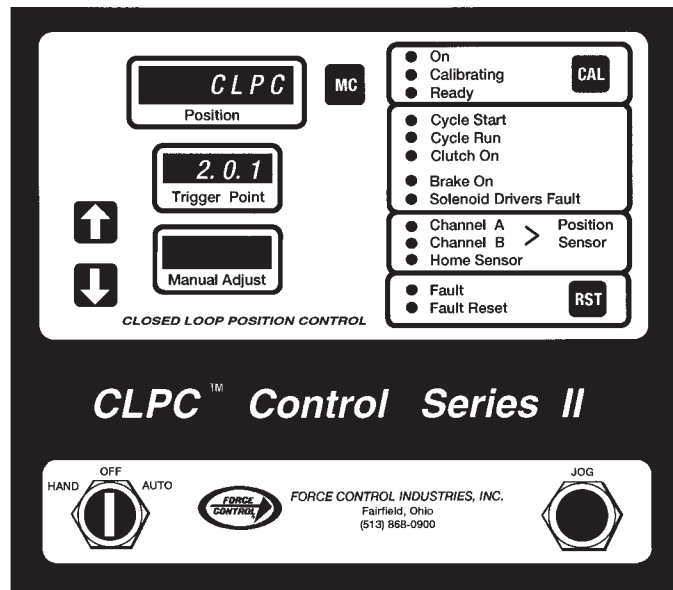

Figure 3.1 - Front Control Panel

3-2 INITIAL SET-UP PROCEDURE

The **CLPC Series II Control** operates by counting pulses from an incremental encoder and when a preset number of pulses (**Max Count +/- Manual Adjust - Trigger Point**) is reached the brake is engaged to stop the drive in position.

A. Setting Max Count

The **Max Count** can only be set or changed by the **UP** and **DOWN** Buttons plus the **MC** Button on the front control panel as described in **STEP #2**.

The **Max Count** is the total number of pulses to complete a single index or cycle.

The **Max Count** can only be set or changed by the **UP** and **DOWN** Buttons plus the **MC** Button on the front panel.

The Max Count is the total number of pulses to complete a single index or cycle.

Step #1 (Set the Resolution or Ratio)

(See Figure 3.2)

The Resolution or Ratio is set with Dip Switch S1 located in the lower left corner of the CPU Board.

With a Differential Line Driver (Optical) Encoder and the Open Collector Quadrature Encoder the setting is "X2".

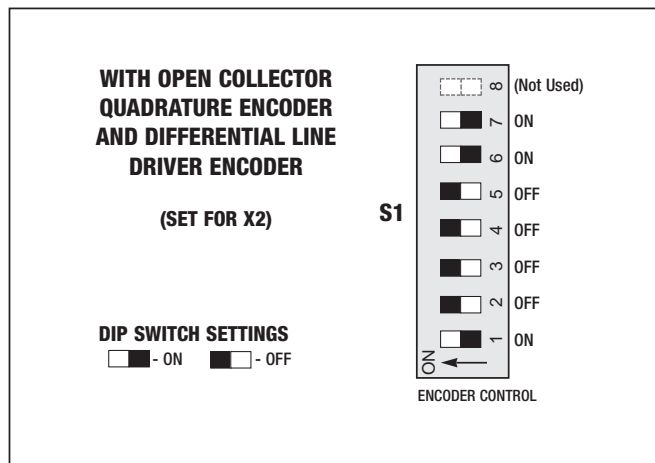

Figure 3.2 - Dip Switch S1 Setting

Step #2 (Set the Max Count)

The Max Count Setting for the Auto Catcher is 120.

1. Set the Max Count on the front of the control panel using the **UP** and **DOWN** Buttons plus the **MC** Button. Push and hold the **MC** Button down while pushing the **UP** or **DOWN** Button to set the **Max Count to 120** which will be shown in the **Position Indicator**. (See Figure 3.3)

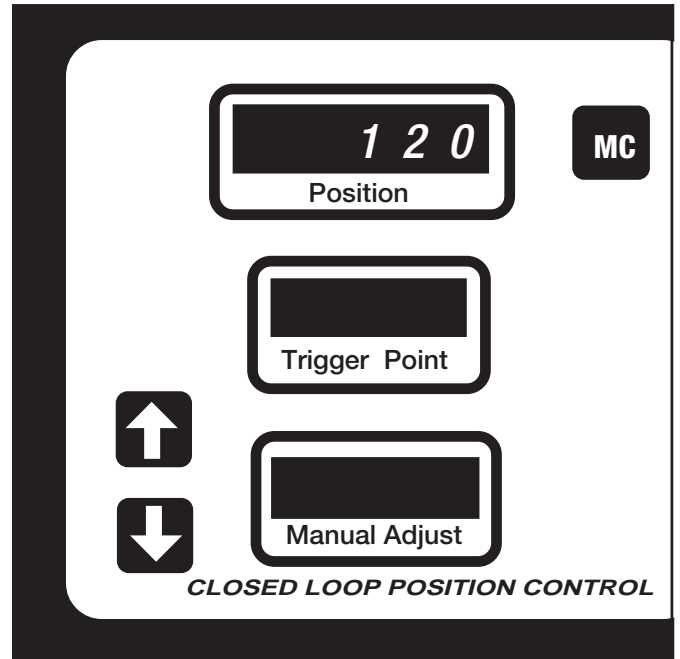

Figure 3.3 - Setting the Max Count

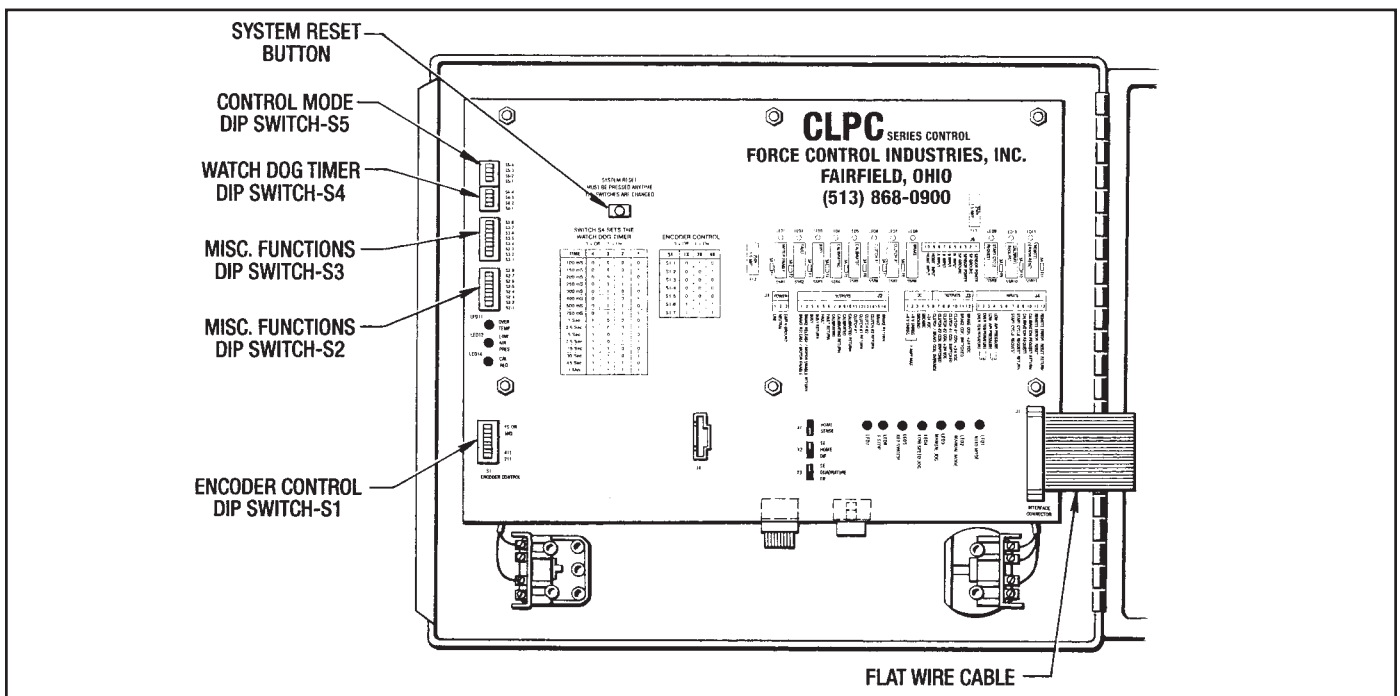

Figure 3.4 - CPU Board Component Location

B. Set Watch Dog Timer (Dip Switch #S4)

The Watch Dog Timer is an internal device which will stop the drive if the cycle is not completed within a set amount of time. This feature is used to protect the clutch and other downstream equipment. When the **Set Time** is exceeded, the control will end the cycle, which will release the clutch, engage the brake and if the motor interlock system is used, turn off the motor. This timer should be set at a time slightly greater than the longest cycle required.

The Watch dog Timer is set with dip switches on S4. The control is factory set for 300 mS. (Only Sw. #3 is turned on.) This time can be adjusted from 100 mS to 1 Minute. (See *Watch Dog Timer Chart and Figure 3.5*)

1. Determine the time required to complete an index.
2. Set the dip switches on S4 to a time slightly greater than one complete index.

WATCH DOG TIMER CHART

(0 = OFF 1 = ON)

TIME	1	2	3	4
100 mS	0	0	0	0
150 mS	1	0	0	0
200 mS	0	1	0	0
250 mS	1	1	0	0
300 mS	0	0	1	0
400 mS	1	0	1	0
500 mS	0	1	1	0
750 mS	1	1	1	0
1 Sec.	0	0	0	1
2.5 Sec.	1	0	0	1
5 Sec.	0	1	0	1
7.5 Sec.	1	1	0	1
15 Sec.	0	0	1	1
30 Sec.	1	0	1	1
45 Sec.	0	1	1	1
1 Min.	1	1	1	1

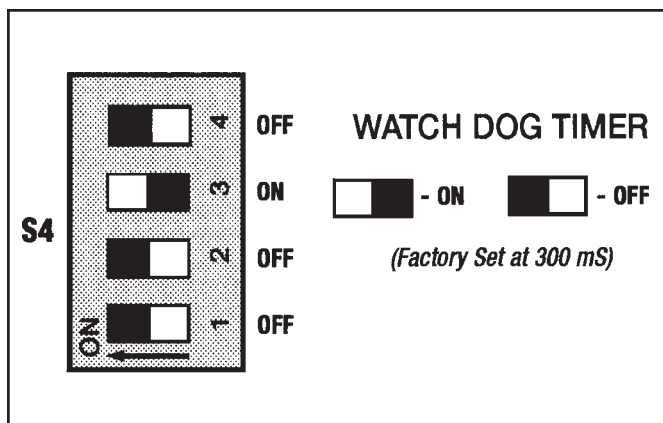

Figure 3.5 - Watch Dog Timer Dip Switch S4

C. Setting Control Mode (Dip Switch #S5)

- **Standard CLPC Mode, One index per cycle input.**
Set all Dip Switches to **OFF**

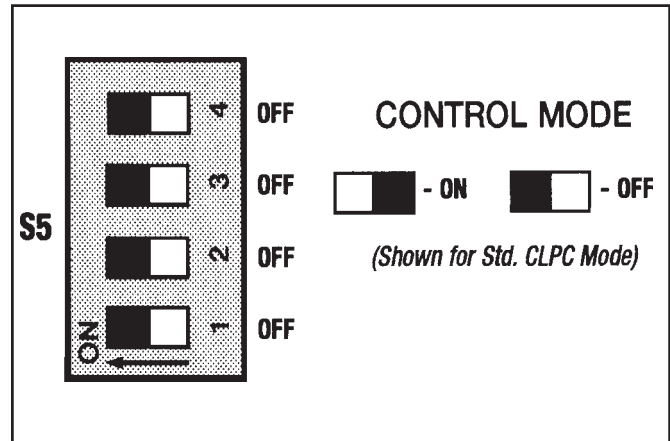

Figure 3.6 - Setting Dip Switch S5 (Control Mode)

D. Setting Misc. Functions (Dip Switch #S2)

- 1 = OFF** - Search for home for initial calibration.
- 2 = OFF** - CLPC
- 3 = OFF** - Emergency/Fault Stop in position.
- 4 = OFF** - Must calibrate before ready when powered up.
ON - Force ready when powered up.
- 5 = OFF** - Zero position when powered up.
ON - Use last known position when powered up.
- 6 = OFF** - Trigger Point calculation only includes pulses while stopping.
- 7 = OFF** - Use 5 index count averaging for trigger point.
- 8 = OFF** - Calibrate in low speed only. (CLPC III)

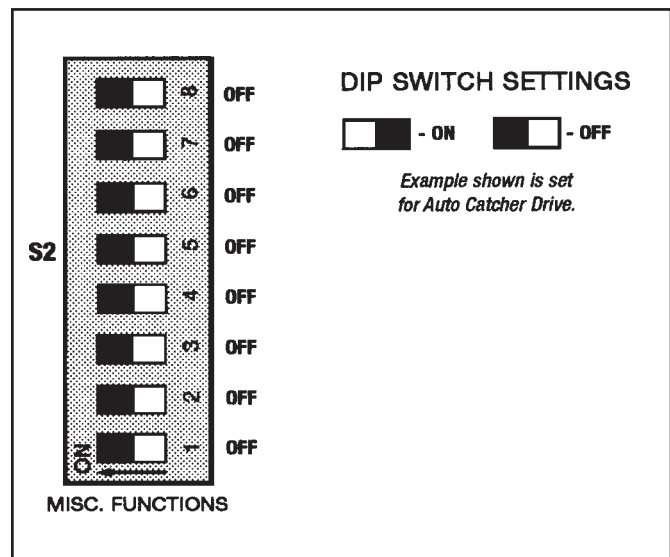

Figure 3.7 - Setting Misc. Functions (Dip Switch #S2)

E. Setting Misc. Functions (Dip Switch #S3)

- 1 = OFF - PLS is locked to home position.
- 2 = OFF - PLS is active in Auto mode only
- 3 = OFF - Stall Detection disabled.
- 4 = Stall Detection Enable Delay at start of cycle.
 OFF - 100 ms (Should work for most applications.)
- 5 = OFF - Not defined.
- 6 = OFF - Not defined.
- 7 = OFF - Not defined.
- 8 = OFF - Not defined.

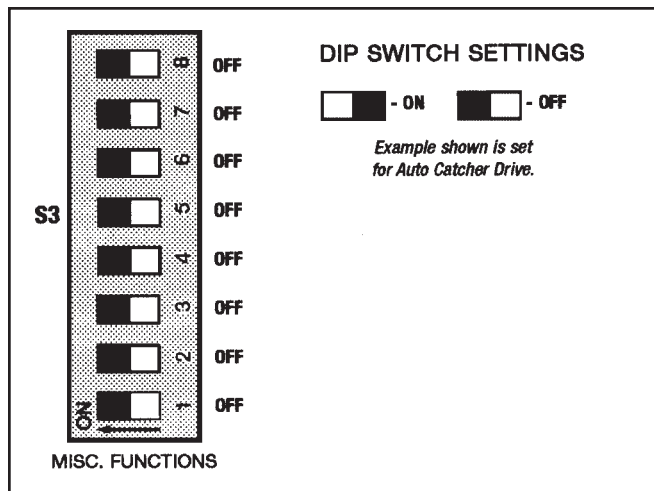

Figure 3.8 - Setting Misc. Functions (Dip Switch #S3)

F. Resetting the CLPC Series II Control

(See Figure 3.4)

Whenever any changes are made to the Dip Switch Settings the control will need to be **Reset**. Press the **Reset Button on the CPU Board** to reset the control.

G. Setting the Jumpers

1. **X1 (On CPU Board)**
This Jumper controls whether the "Home" LED on the front panel is normally ON or OFF. (See Page 50)
2. **X2 and X3 (On CPU Board)**
These Jumpers select whether the Encoder Channels are Single Ended or Differential Line Driver Inputs. (See Page 50)
3. **JP1 to JP11 (On Power Supply Board)**
These Jumpers are for the (11) possible Solid State Relays. They are for N.C. or N.O. operation of the relays. (See Page 51)
4. **JP12 and JP13 (On Power Supply Board)**
These determine a N.C. or N.O. operation of the High Temperature Switch and Low Air Pressure Switch. (See Page 51)

5. JP14 (On Power Supply Board)

This Jumper sets the Encoder Power. Use 5VDC for an Optical Differential Line Driver Encoder and 12VDC for an Open Collector Quadrature Encoder. (See Page 51)

3-3 DESCRIPTION OF CALIBRATION METHOD

As with any Positioning Control the system initially needs to be calibrated to relate the electronic system with the mechanical system. This is done by establishing a **Trigger Point**, which is the number of pulses at which the brake is energized to stop the drive at the required position.

A Home Sensor is used to indicate to the control where the Home Position is located. In operation the Home Sensor Pulse (Z Channel) re-zeros the position. In other words the control begins counting from the Home Sensor Pulse (Z Channel) on each index. This eliminates the possibility of accumulated error. The **Manual Adjust** is used to move the actual stop position the required number of pulses from the home position, either positive or negative. Therefore with a positive 10 pulses in the manual adjust the drive should stop at 10. If a home sensor pulse (Z Channel) is not seen, the control will re-zero when max count is reached.

Position Error is detected by comparing the required stop position against the actual stop position. The required stop is Max Count plus or minus Manual Adjust.

Example: With Manual Adjust set at 0 the required stop is at 0. With Manual Adjust set at +10 the drive should stop at 10. If the actual stop is 11 an error of +1 pulse is fed into the correction system.

The Calibration Method used for the Auto Catcher application is **Absolute Positioning**.

A. Absolute Positioning

An **Absolute Position Application** is where the drive makes a complete cycle stopping at a fixed position in relation to the Home Sensor. The Max Count and Home Sensor Pulse are related to revolution position of the shaft.

In order for the control to find the Home Position it must be Calibrated. The Calibration Procedure runs the drive until a signal is received from the home sensor. (If no signal is received the drive will run continuously until the watch dog timer times out.) At this point the CLPC will perform one complete index. The control determines how many pulses were required for the drive to stop and adjusts the Stop Signal Position "Trigger Point" to cause the drive to stop at the Home Position. The second index will run to the Trigger Point, at which point the brake will engage stopping the drive in position. This position will be related to the Home Position by the number of pulses set in the Manual Adjust.

For Absolute Positioning where the drive needs to find and relate to a Home Position before operating, set Dip Switch #S2-1 to **OFF**.

3-4 CALIBRATION PROCEDURE

(See Figure 4.1 for Front Control Panel)

A. Absolute Positioning

1. Set Dip Switch #S2-1 to **OFF** for Absolute Positioning. Press the internal Reset Button.
2. Adjust the air pressure to the Clutch and Brake . (See Clutch/Brake Manual for proper pressure settings.)
3. Check to see if all personnel are free and clear of the operating equipment. Unlock and turn the power **ON** to the drive motor and control. The Software Version installed in your system will temporarily show in the Trigger Point Display.
4. Set the **Manual Adjust to 0** using the **UP** and **DOWN** Buttons.
5. Turn the **HOA** Switch to **HAND** position. If you are using the Motor Interlock System the drive motor or motors should come on. The green **ON** light should come on.
6. Push the **CAL** Button . The clutch engages and will run until it receives a Home Pulse (Z Channel) that will re-zero the control position and will perform one full index from that point.
7. Push the **CAL** Button a second time. The Drive will index and should stop in position. The green **READY** Light should come on and the **POSITION** Display should show "0". **NOTE:** Zero will not be displayed if the Manual Adjust is not set to "0".
8. Jog the machine several times with the **JOG** Button.

3-5 SET MANUAL ADJUST

(See Figure 4.1 for Front Control Panel)

The Manual Adjust allows the operator to adjust the Stop Position to some position before or after the Home Sensor Position. It is set in pulses of the encoder and can be positive or negative. A negative setting stops the drive before the Home Sensor Position and a positive setting stops the drive after the Home Sensor Position. **NOTE:** A setting in the **Manual Adjust** increases or decreases the number in the **Trigger Point Display** by the same amount. Also the number in the **Position Display** will be adjusted by the same amount on the next stop.

The Manual Adjust can be changed without stopping the drive, however the changes will not be accepted while the control is busy.

1. Push the **UP** Button to enter a positive number and the **DOWN** Button to enter a negative number.

The adjustment range is plus or minus 1/4 of Max Count, or plus or minus 1999 which ever is less.

3-6 AUTOMATIC OPERATION

(See Figure 4.1 for Front Control Panel)

The CLPC Series II Control is now ready for Automatic Operation.

1. Turn the **HOA** Switch to **AUTO**. The motors should be running and the brake on.
2. When a Start Signal is received the drive will index to position, stop and wait for the next Start Signal.
3. Adjust the time delay in the PLC program between the time you see the shingle and the time the drive indexes so the drive indexes just as the shingle is completely in the starwheel. **NOTE:** This adjustment is not in the CLPC Series II Control.

3-7 CLEARING A JAM

If a jam occurs:

1. Turn the "**HOA**" Switch to **OFF**. This will stop the motor and exhaust the Brake Release Valve. If the Watchdog Timer timed out, the drive motor should already be stopped.

WARNING

Before attempting to clear a jam in the starwheels, the power to the drive motor circuit should be disconnected and locked out. Also make sure the starwheels has completely stopped rotating.

Power to the CLPC Control should be maintained but not to the main drive motor.

2. Clear the Jam. The starwheels can be moved by hand to clear a jam without losing position. (The control power must remain on.)

CAUTION

Before restoring power to the main motor be sure all personnel are clear of the drive and starwheels. Unlock and start the main drive motor.

3. After the jam is cleared, check for a "**FAULT**" light and a Fault **E-4** indicated in the **Trigger Point Display**. If on, push "**RESET**". This should clear the Fault.
4. Turn the "**HOA**" Switch to "**HAND**". The main motor should start.
5. Jog the starwheels until they are in position. (Usually 1 or 2 times is sufficient.)
6. Turn the "**HOA**" Switch to "**AUTO**" and resume production.

Section 4

TROUBLE SHOOTING

Trouble shooting the CLPC Control Series II is greatly simplified due to Indicator Lights and Error Codes built into the Front Control Panel. (See Figure 4.1) Section 4-1 describes the Front Control Panel and Section 4-2 describes the “Error Codes” shown in the “Trigger Point” Display. Corrective measures are also given to correct the “Fault” for each “Error Code”.

4-1 DESCRIPTION OF FRONT CONTROL PANEL

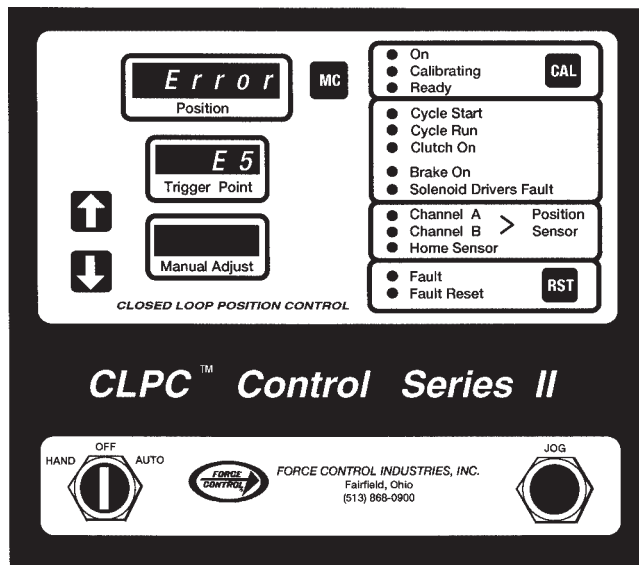

Figure 4.1 - Front Control Panel

A. DISPLAYS

- 1. Position** - Shows relative position of the Encoder Counter. It should theoretically stop at 0. Due to slight variations in stopping position and depending on resolution, it may read 1 or 2 if over, and 119 or 118 if under. (Only if Max Count is set to 120.)
- 2. Trigger Point** - This is the count at which the brake is engaged before the desired stopping point. It is continually adjusted by the Automatic Closed Loop Control. When the Fault light is on an Error Code is indicated in the Trigger Point Display. The installed Software Version will momentarily be displayed when the control is first turned on.
- 3. Manual Adjust** - Displays the manual adjustment to the Stopping Point. This adjustment is the number of pulses from the Home (Z Channel) marker.

B. INDICATOR LIGHTS

- 1. On** - Indicates power is on to the CLPC Series II Control and the **H-O-A** Switch is in **Hand** or **Auto**.
- 2. Calibrating** - Indicates the control is in the Calibrating Mode.
- 3. Ready** - Indicates that the control is calibrated and ready for operation.
- 4. Cycle Start** - Lights when the control gets a signal to start the cycle either from the “JOG” switch or PLC input.
- 5. Cycle Run** - Lights while the cycle is in operation.
- 6. Clutch On** - Indicates that the Clutch Solenoid is energized.
- 7. Brake On** - Indicates that the Clutch Solenoid is de-energized.
- 8. Solenoid Driver Fault** - Indicates that there is a short or overload in the valve solenoid or wiring.
- 9. Channel “A”** - Indicates a pulse from “A” channel of the Quadrature Encoder.
- 10. Channel “B”** - Indicates a pulse from “B” channel of the Quadrature Encoder.
- 11. Home Sensor** - Indicates a pulse from the Home Sensor (Z Channel).
- 12. Fault** - Indicates a Control Fault.
- 13. Fault Reset** - Indicates that the Fault Reset Button is pushed.

C. SWITCHES

- 1. HAND/OFF/AUTO** - Switch used to select “Hand”, “Off” or “Auto” mode.
- 2. JOG** - Used to manually index the control when selector is in “Hand” mode.

D. BUTTONS

- 1. CAL** - Used to initiate the Calibration Cycle.
- 2. RST** - Resets error after Control Fault.
- 3. Manual Adjust “UP”** - Adjusts Stopping Position in a positive direction.
- 4. Manual Adjust “DOWN”** - Adjusts Stopping Position in a negative direction.
- 5. MC (Max Count)** - Used to set the total number of pulses to complete a single index or cycle.

4-2 ERROR CODES

1. **Error Code "E-1"** - Solenoid driver overload. Usually caused by a short in the valve solenoid or wiring.

Correction:

- (a) Check and/or replace wiring.
(b) Check and /or replace valve or solenoid.

2. **Error Code "E-2"** - Indicates an over temperature condition in the *Posidyne* Clutch/Brake Unit.

Correction:

- (a) Check for overheating in the *Posidyne* and correct problem. (See *Posidyne* Service Manual)

3. **Error Code "E-3"** - Low air pressure.

Correction:

- (a) Check the air pressure with the optional Low Pressure Switch or Pressure Gauges on the Accumulator and correct any problems. (See *Posidyne* Service Manual)

4. **Error Code "E-4"** - Watchdog Timer expired.

Correction:

- (a) Push "RST" Reset on front control panel.
(b) If tripping continues, check #S4 Dip Switch settings.

5. **Error Code "E-5"** - Count set to equal 1 or 0. (Count cannot equal 1 or 0)

Correction:

- (a) Reset Max Count to a value greater than 1.

6. **Error Code "E-6"** - The counts required to stop is greater than the total cycle counts.

Correction:

- (a) Increase the total cycle time or shorten the stopping time to be less than the total cycle.
(b) Channel A and B of encoder may be backwards. Swap A and B channel wires if necessary.

7. **Error Code "E-7"** - High Speed Interrupt (Pulses per Second too high). Maximum allowable counts per second of Pulse Counter is 7200 counts per second.

Correction:

- (a) Set ratio or change Encoder to reduce maximum counts per second to be less than 7200.

8. **Error Code "E-8"** - Calibration data invalid.

Correction:

- (a) Control needs to be Re-Calibrated
(See Section 3-3).

9. **Error Code "E-9"** - Mode changed to **OFF** while in motion or calibrating.

Correction:

- (a) Turn **HOA** Switch to **Hand** or **Auto** Position.

10. **Error Code "E-10"** - Twists per Picket = 0
(*PosiWeave* Only)

11. **Error Code "E-11"** - Emergency Stop.

Correction:

- (a) Reset **Emergency Stop** button. (CLPC III only.)

12. **Error Code "E-12"** - Undefined Model selected by Dip Switch.

Correction:

- (a) Correct dip switch settings.

13. **Error Code "E-43"** - Stall Detection - Failure to start.

Correction.

- (a) Check to be sure machine is not jammed.
(b) Check to be sure motor is running and Posidyne input rotating.
(c) Check air supply to control valve.

14. **Error Code "E-44"** - Stall Detection - Stall occurred while clutch was engaged.

Correction.

- (a) Check to be sure machine is not jammed.
(b) Check to be sure motor is running and Posidyne input rotating.
(c) Check air supply to control valve.

15. **Error Code "E-50"** - Stack Overflow

Correction:

- (a) Replace CPU board.

16. **Error Code "E-51"** - Stack Under flow

Correction:

- (a) Replace CPU board.

17. **Error Code "E-52"** - Software Timer 0 Interrupt Request missing.

Correction:

- (a) Replace CPU board.

18. **Error Code "E-53"** - Software Timer 1 Interrupt Request missing.

Correction:

- (a) Replace CPU board.

19. **Error Code "E-54"** - Software Timer 2 Interrupt Request missing.

Correction:

- (a) Replace CPU board.

20. **Error Code "E-55"** - Software Timer 3 Interrupt Request missing.

Correction:

- (a) Replace CPU board.

21. Error Code "E-56" - Power Unsafe, or Manual Reset, or Watch Dog Timer timed out.

Correction:

- (a) Reset error.
- (b) Replace CPU board if problem persists.

22. Error Code "E-80" - Software changed, proceed at your own risk. (*E-Prom software was changed from one version to another.*)

Correction:

- (a) Push **Reset** button on CPU board.
- (b) Re-calibrate.
- (c) Replace CPU board if calibration does not fix problem.

23. Error Code "E-81" - Configuration trashed, default loaded.

Correction:

- (a) Push **Reset** button on CPU board.
- (b) Re-calibrate.
- (c) Replace CPU board if calibration does not fix problem.

24. Error Code "E-82" - Counters trashed, set to zero.

Correction:

- (a) Push **Reset** button on CPU board.
- (b) Re-calibrate.
- (c) Replace CPU board if calibration does not fix problem.

25. Error Code "E-83" - Saved position invalid, set to zero.

Correction:

- (a) Push **Reset** button on CPU board.
- (b) Re-calibrate.
- (c) Replace CPU board if calibration does not fix problem.

26. Error Code "E-84" - DIP Switch settings changed.

Correction:

- (a) Push **Reset** button on CPU board.
- (b) Re-calibrate.
- (c) Replace CPU board if calibration does not fix problem.

4-3 TROUBLE SHOOTING AREAS

Trouble shooting the CLPC Control Series II is divided into (5) five areas based on the symptoms. The basic areas are:

A. DRIVE WILL NOT INDEX

- B. DRIVE STOPS OUT OF POSITION (Same position each time.)
- C. DRIVE STOPS OUT OF POSITION (Different position each time.)
- D. DRIVE DOES NOT STOP

A. DRIVE WILL NOT INDEX

1. CLPC Control Series II "ON" Light not on.

- (a) Turn H-O-A switch to "HAND" or "AUTO"
- (b) Check main power to control.
- (c) Check the AC Fuse and the DC Fuse and replace if necessary.

2. "Ready" Light not on.

- (a) Unit not calibrated. Run calibration cycle
- (b) If control will not calibrate, continue check list.

3. "Fault" light on and "Error Code" in TRIGGER POINT Display.

- (a) Push "RST" button on front control panel. If this does not correct the problem, push the "Fault Reset" button inside front cover. Then push the "RST" button on front control panel again
- (b) If this does not clear the Fault, check the Error Codes in Section 4-2.

4. "Solenoid Driver Fault" light on. (Usually caused by a short in the wiring or a valve solenoid failure.)

- (a) Repair or replace solenoid valve or wiring.

5. "Cycle Start" light does not come on when signal is initiated. This indicates that the Control is not receiving a signal from the PLC.

- (a) Check the PLC output and wiring.
- (b) Check Fuse #F9.
- (c) Be sure correct input relay is installed.
- (d) Check to be sure that voltage is being applied to relay.

6. "Cycle Run" light stays on continuously. Drive skips an index in high cycle applications. Indicates a new start signal was received before the drive completed the previous cycle. The control can not receive a new start signal until the previous cycle is complete. The "Cycle Run" light should turn off after each cycle. To correct this problem:

- (a) Reduce the Cycle Rate of the machine.
- (b) Speed up the drive to reduce Cycle Time.
- (c) Increase air pressure to reduce Cycle Time.
- (d) Decrease PLC Scan Time.

7. Motor not running.

(a) Check the drive motor, relay, fuses, motor starter and interlock. Correct any problem and re-start.

8. Clutch does not engage.

(a) Check air pressure. (See All Products Catalog for Torque vs. Pressure Information.)

(b) Check the Solenoid Valve for proper operation and replace if necessary.

(c) Check the air lines for any leaks. Repair leaks or fittings.

(d) Check and drain the water out of the Accumulators.

9. Watchdog Timer times out and shuts off control.

(a) Push "RST" Reset on front panel. If tripping continues check Dip Switch setting.

B. DRIVE STOPS OUT OF POSITION (Same position each time.)

1. Caused by machine not aligned with the Home Position.

(a) Realign with the Home Position.

2. Caused by a setting in the Manual Adjust.

(a) Set Manual Adjust back to zero. **NOTE:** Manual Adjust will remain in the system even if the control is off, and is used when re-calibrated.

C. DRIVE STOPS OUT OF POSITION (Different position each time.)

1. Count or rotation does not equal the correct amount of rotation of the driven machine.

(a) Check count and ratio to assure that the number of revolutions at the Encoder equals the desired degree of rotation of the driven machine.

2. Quadrature Encoder counting error.

(a) Check wiring for shorts, breaks, etc.

(b) Encoder wires not properly shielded or not isolated from high voltage wires. (See Section 2-6, 2-7 and 2-8 for proper installation.)

(c) Encoder direction not correct. Check sequence of channel A and B lights. (See Section 3, START-UP)

D. DRIVE DOES NOT STOP

1. Brake does not engage.

(a) Check air pressure. (See All Products Catalog for Torque vs. Pressure Information.)

(b) Check Solenoid Valve for proper operation and replace if necessary.

(c) Check Brake Release Valve for proper operation and replace if necessary.

(d) Check air lines for leaks. Repair leaks or tighten fittings.

(e) Check and drain water out of the accumulators.

2. Brake on - light does not come on.

(a) Call factory.

Section 5

GENERAL MAINTENANCE

5-1 VISUAL CHECKS

1. Check for wear and abrasion on all wire cables, hoses and drive belts.
2. On all drive belts, check for dirt build-up, loose belts and belt wear.
3. Check to see if the muffler on the air valves are plugged. Replace or clean with a suitable solvent as needed.

5-2 ACCUMULATOR TANKS

1. Drain water from the accumulator tanks daily, or as needed, to keep water out of the system. (See Figure 7.2 for location of the drain cocks.) An automatic drain system can be installed if water is a serious problem. Contact the factory for further information.

5-3 GEARBOXES

To achieve maximum gear life, the Gearbox Input Shaft should be manually rotated 90°, in respect to the "Home Position", once a year.

1. Loosen the Drive Belt (#742) and manually rotate the Gearbox Input Shaft 90°. Retighten the Drive Belt. (See Section 6-1 and 6-2 for procedure.)
2. Loosen and rotate starwheels 22-1/2° to correct position. (See Sections 2-2 and 2-3 for procedure.)

5-4 COLLET BOLTS AND COUPLINGS

Check the torque on the collet bolts and coupling locking elements after the first hour of operation. Then check weekly and finally, annually or as needed thereafter.

5-5 BELTS AND PULLEYS

Inspect the belts and pulleys weekly for proper tension and wear. Adjust tension if necessary. Check for any build-up of foreign material in the pulley teeth. **Any foreign material in the teeth will cause position problems and belt breakage.**

5-6 LUBRICATION

(See Figure 5.1 Below)

A. Posidyne CLUTCH/BRAKE LUBRICATION

1. Check the fluid level in the *Posidyne* daily. The oil level should be at the mid point of the sight gauge and look clean and red in color.
2. After 2 months of operation drain and refill the unit with new oil. **Mobil ATF 210 (Type F)** is recommended but **Mobil Multi-Purpose ATF** is acceptable. Change the oil every 6 months thereafter. Visually check the Sight Gauge and remove and clean if needed.

CAUTION

Open the disconnects to the Drive Motor before attempting to change the oil.

Do not overfill the Drive Unit. Excess oil will cause the unit to overheat.

B. GEARBOX LUBRICATION

1. Check and refill the oil to the proper level in the Gearboxes every 6 months, or as needed. Use **Mobil HD-80W90 Gear Oil**.

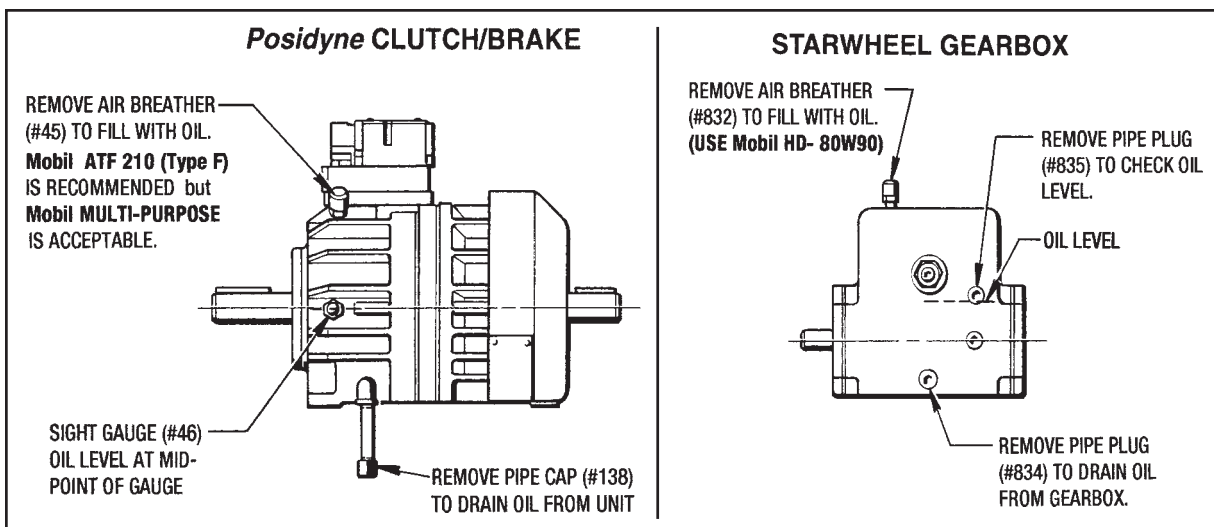

Figure 5.1 - Lubrication

Section 6

REPAIR AND REPLACEMENT

WARNING

Before attempting any repairs to the Auto Catcher Assembly, shut off all electrical power, turn off the air supply and lock them out to avoid any possibility of personal injury.

6-1 REMOVAL OF DRIVE BELTS AND SHEAVES

(See Figure 7.1)

A. INPUT SHEAVES AND DRIVE BELT

1. Loosen (4) Hex Nuts (#716) which holds the Drive Motor to the Adjustable Motor Base (#701). **Do not remove these Nuts**
2. Turn the Adjusting Screw on the Motor Base (#701) until the Drive Motor slides up enough to remove the Drive Belt (#714) from the Sheaves (#710) and (#711).
3. Remove Drive Sheaves (#710) and (#711). The Sheaves have a Taper Lock Bushing in them. (See Figure 6.1 for Removal Procedure.)

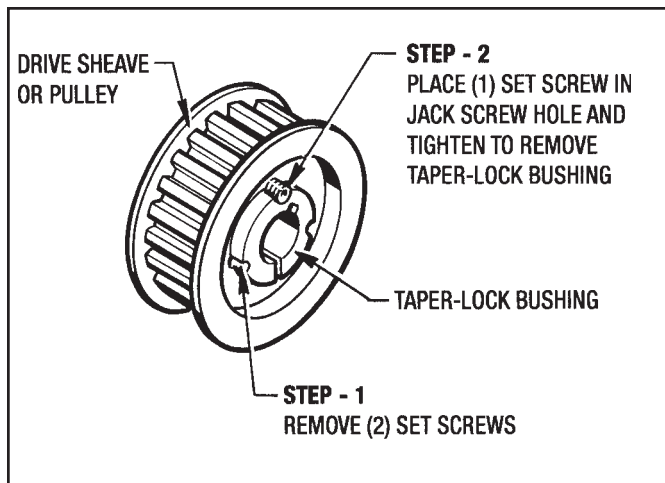

Figure 6.1 - Removal of Drive Sheaves

B. OUTPUT SHEAVES AND DRIVE BELT

1. Loosen the *Posidyne* Mounting Bolts (#705). **Do not remove these bolts.**
2. Back out the (2) Jack Screws (#781) at the rear of the *Posidyne* and advance the front Jack Screw (#781) to slide the *Posidyne* back until the Drive Belt (#742) can be removed from the (2) Sheaves (#738).
3. Remove the (2) Sheaves (#738). These Sheaves also have a Taper Lock Bushing in them. (See Figure 6.1 for Removal Procedure.)

6-2 INSTALLING DRIVE BELTS AND SHEAVES

(See Figure 7.1)

A. OUTPUT SHEAVES AND DRIVE BELT

1. Install the (2) Sheaves (#738) and Bushings (#740) and (#741) back on their respective shaft. (See Figure 6.2 for Installation Procedure.)

Be sure that the Sheaves are properly aligned with each other. (See Figure 6.3 for Alignment Procedure.)

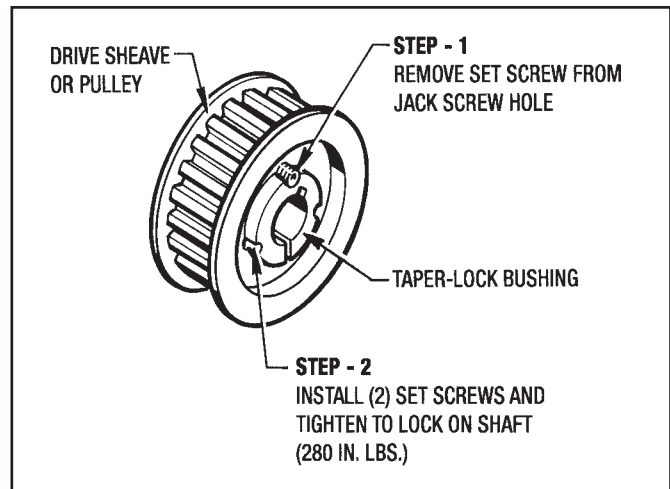

Figure 6.2 - Installation of Drive Sheaves

2. Place the Drive Belt (#742) onto the Sheaves (#738).
3. Tighten the belt by sliding the *Posidyne*, using the Jack Screws (#781).

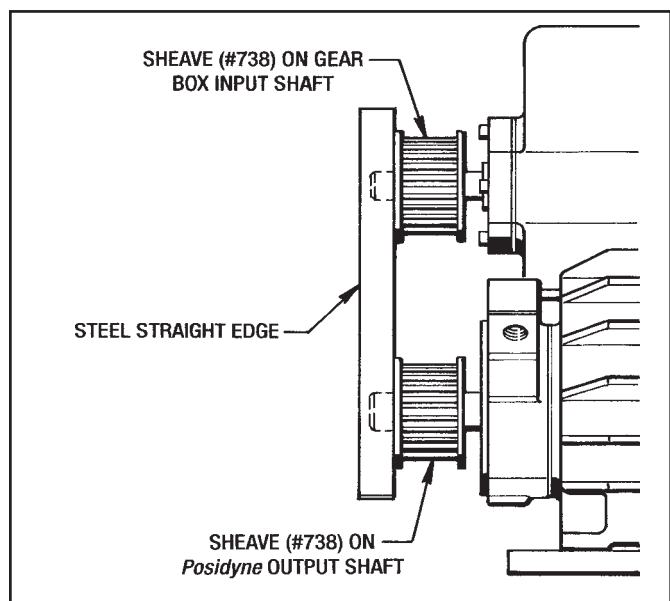

Figure 6.3 - Sheave Alignment

IMPORTANT
Make sure the Drive Belt is properly tensioned.
(See Figure 6.4 for Tensioning Procedure.)

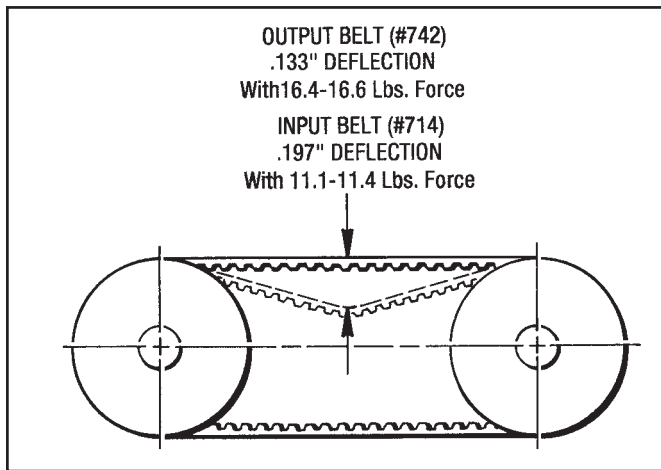

Figure 6.4 - Drive Belt Tensioning

4. After the Drive Belt has been properly tensioned, lock-down the Jack Screws (#781) with Hex Nuts (#733).
5. Retighten the *Posidyne* Hold-Down Bolts (#705).

B. INPUT SHEAVES AND DRIVE BELT

1. Using the same procedure as described for the Output Sheaves and Drive Belt, install Sheave (#710) on the *Posidyne* Input Shaft and Sheave (#711) on the Drive Motor Shaft. *(See Figure 6.2 and 6.3 for Installation and Alignment Procedure.)*

2. Place the Drive Belt (#714) back on the Sheaves and tighten the Belt Tension with the Adjusting Screw in the Motor Mount (#701).

Check and adjust the Belt Tension as described in *Figure 6.4*.

3. Lock-down the Drive Motor with Hex Nuts (#716).

6-3 REMOVING *Posidyne* CLUTCH and BRAKE

(See Figures 7.1, 7.2, 7.3 and 7.6)

1. Remove the Drive Belts as described in 6-1.
2. Disconnect the Brad Harrison Cables from the Manifold Mounted Valve and the Positioning Pick-Up Assembly.
3. Disconnect the (2) air hoses from the Manifold Mounted Valve as shown in *Figure 7.2*.
4. Remove the (4) Mounting Bolts (#705), (4) Nuts (#703) and (4) each Washers (#707 and #749).
5. Using an overhead hoist and sling, lift the *Posidyne* off of the base plate.

For complete Disassembly Instructions on the *Posidyne* Clutch and Brake Unit see included Manual #502-01-010

6-4 INSTALLING *Posidyne* CLUTCH and BRAKE

(See Figures 7.1, 7.2, 7.3 and 7.6)

Make sure that the mounting surface of the base plate is clean and free of any dirt and foreign material.

1. With a sling and overhead hoist, set the *Posidyne* in position on the base plate.
2. Attach the *Posidyne* with (4) Mounting Bolts (#705), (4) Hex Nuts (#703) and (4) each Washers (#707 and #749). **Do not tighten these bolts at this time.**
3. Install the Encoder Assembly onto the *Posidyne* Output Shaft as described in 6-7 and 6-10.
4. Install the Input and Output Drive Belt and Sheaves as described in 6-2.

IMPORTANT

Make sure the Sheaves are properly aligned as shown in *Figure 6.3* and the Belts are tightened to the proper tension as indicated in *Figure 6.4*.

5. Tighten down the *Posidyne* Hold-Down Bolts (#705) and the Drive Motor Hold-Down Nuts (#716)
6. Hook up the air lines to the Manifold Mounted Control Valve.
7. Attach the electrical cable to the Encoder Assembly and the electrical cable to the Manifold Mounted Control Valve.

6-5 REMOVAL OF OPEN COLLECTOR QUADRATURE ENCODER

(See Figure 7.3)

The Output Drive Belt (#742) and Drive Sheave (#738) must first be removed from the *Posidyne* Output Shaft. Refer to **Section 6-1-B. REMOVING OUTPUT SHEAVES AND DRIVE BELT.**

1. Remove the 5-Pin Brad Harrison Cable (#259) from the Encoder Assembly.
2. Remove the Housing Cover (#253) by taking out the (4) Screws (#268).
3. Take the (2) Attaching Screws (#76) and (2) Washers (#257) out of the Pick-Up Housing (#17) and pull the housing off of the *Posidyne* output shaft and the pilot flange.
4. Take the Key (#181) out of the output shaft. Loosen the Set Screw (#154) and slide the Pulse Gear (#186) off the output shaft.

6-6 REMOVAL OF QUADRATURE SENSOR (#355) AND MAGNETIC PICK-UP (#22)

(See Figure 7.3)

NOTE: The Encoder Assembly does not have to be removed to replace the Sensors. Only the Drive Sheave (#738) and the Drive Belt (#742) has to be taken off.

1. Remove the (4) Screws (#225) and take the Top Cover (#372) off the Pick-Up Housing (#17).
2. Disconnect the wires from the Brad Harrison connectors to both sensors.
3. Loosen the Set Screw (#241) and pull the Magnetic Pick-Up (#22) out of the housing. **Do not remove this screw.**
4. Remove the (2) Screws (#226) and lift the Quadrature Sensor (#355) out of the housing.
5. If any Shims (#214) are under the Sensor, remove them and save for Reassembly.

6-7 INSTALLING OPEN COLLECTOR QUADRATURE ENCODER

(See Figure 7.3)

1. Replace Key (#234) into the *Posidyne* output shaft if it was removed.
2. Attach the Encoder Housing (#17) to the output housing with (4) Screws (#76) and (4) Washers (#257).
3. Slide the Pulse Gear (#186) on to the output shaft, aligning the groove in the pulse gear with the alignment face of the encoder housing, as shown in View B-B in Figure 6.6. Tighten Set Screw (#154).

Jump ahead to Section 6-8 and install the Quadrature Encoder (#355) and the Magnetic Pick-Up (#22).

4. Attach the Top Cover (#372) with (4) Screws (#225) and the Front Cover (#253) with (4) Screws (#268).

6-8 INSTALLING QUADRATURE ENCODER (#355) AND MAGNETIC PICK-UP (#22)

(See Figure 7.3)

Before installing the Quadrature Encoder and Magnetic Pick-Up a Special .015" Shim must be made to set the Gap between them and the Pulse Gear. (See Figure 6.5)

A. QUADRATURE ENCODER (#355)

1. Looking through the hole where the Encoder is to be placed, check to see that the Pulse Gear (#186) is in position so the teeth will be aligned with the Encoder.
2. Position the Encoder so the (2) mounting holes are lined up with the holes in the housing. Insert the Sensor into the slot and attach with (2) Screws (#226).

NOTES:

1. The holes are offset to one side so the Encoder can only be installed one way.

2. Do not install any Shims (#214) at this time. **The Gap must be checked first.**

3. Check the Gap between the Pulse Gear and the Encoder with the Special .015" Shim that you made. If necessary, remove the Encoder and place Shims (#214) under the Encoder. (Usually .015" is sufficient.) Re-attach the Encoder and re-check the Gap. (See Figure 6.6)
4. Connect the sensor wires to the Brad Harrison connector wires. (See Figure 2.5 for Wiring Diagram)

B. MAGNETIC PICK-UP SENSOR (#22)

(See Figure 6.6)

1. Visually check through the hole to see if the single tooth in the Pulse Gear (#186) is aligned with the Sensor and that the teeth for the Quadrature Encoder will not be visible to the Magnetic Pick-Up Sensor.

The Magnetic Pick-Up Sensor has a **Scribed Line** down one side of it. To facilitate installation, highlight this **Scribed Line** with a felt tip pen.

2. Insert the Magnetic Pick-Up Sensor (#22) into the hole with the **Scribed Line** in position as shown in Figure 6.6, View A-A.
3. Insert the Special .015" Shim in between the Pulse Gear and the Sensor. Tighten the Set Screw (#241).
4. Connect the sensor wires to the Brad Harrison connector wires. (See Figure 2.5 for Wiring Diagram.)

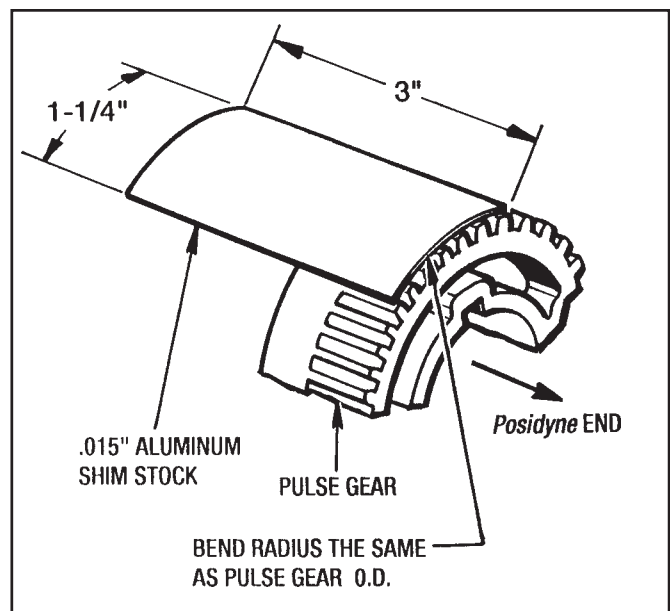

Figure 6.5 - Sensor Gap Shim

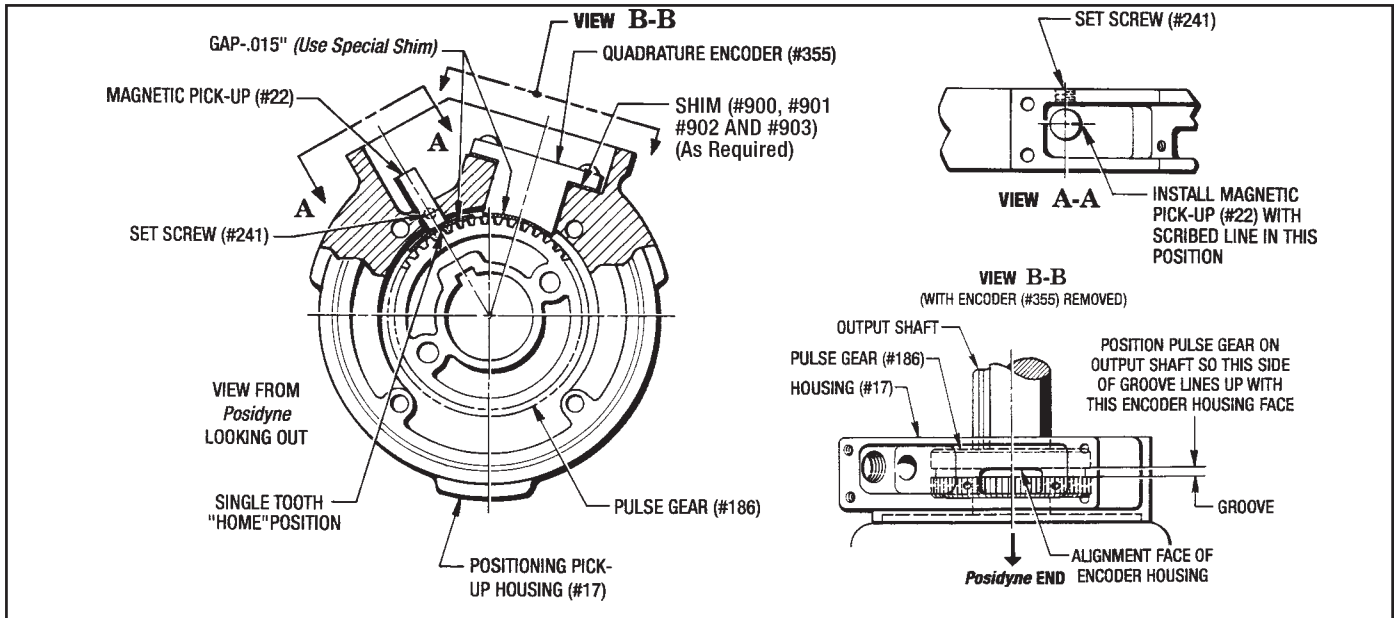

Figure 6.6 - Position Sensors Installation

6-9 REMOVAL and DISASSEMBLY of DIFFERENTIAL LINE DRIVER ENCODER ASSEMBLY (Optical Encoder)

(See Figure 7.4)

Any Drive Sheaves, Pulleys or Couplings must first be removed from the output shaft.

1. Take out the (4) Screws (#225) and remove the Top Cover (#372) and the upper Gasket (#19) from the Upper Enclosure (#18). This gasket is reusable.
2. Pull the Insulator (#373) up and out of the Upper Enclosure (#18).
3. Loosen the (2) captive screws in the Cable Connector (#368) and unplug it from the Circuit Board (#355). (See Figure 6.7)

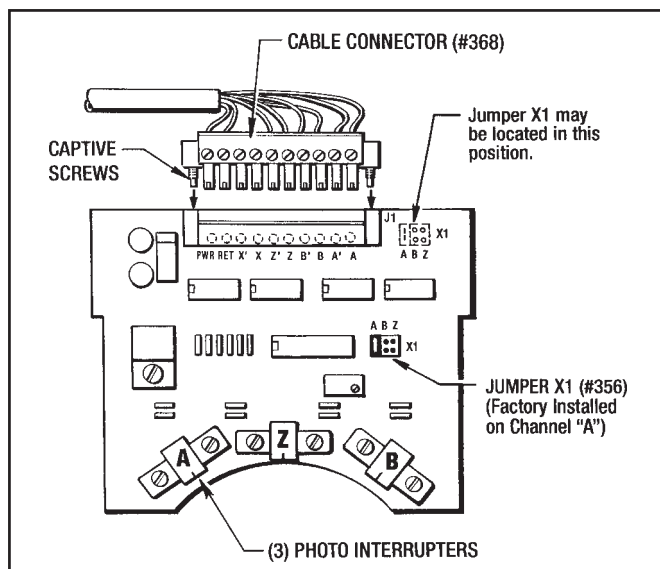

Figure 6.7 - Circuit Board Connector

4. Pull the Cable Grommet (#260), Cable (#259) and Cable Connector (#368) out of the Top Enclosure slot.
5. Remove the (2) Cap Screws (#77) and take the Upper Enclosure (#18) and lower Gasket (#19) off of the Disc Housing (#17). This gasket is also reusable.
6. Pull the Circuit Board (#355) straight up and out of the Disc Housing (#17).
7. Remove the (4) Screws (#76) and pull the Disc Housing off of the *Posidyne* mounting face.

CAUTION

Be very careful not to bump or bend the Optical Disc (#186) which is still attached to the output shaft or damage the Dirt Seal (#269) located in the Disc Housing (#17).

8. If the *Posidyne* still has the main driving key in the output shaft, remove it at this time.
9. Loosen the Set Screw (#154) and pull the Optical Disc Assembly (#186) off of the output shaft.
10. Remove the Key (#234) then the Spacer (#270) from the output shaft.
11. Check the Dirt Seal (#269) in the Disc Housing (#17) and remove it if necessary.

6-10 REASSEMBLY and INSTALLATION of DIFFERENTIAL LINE DRIVER ENCODER (Optical Encoder)

(See Figure 7.4)

1. First slide the Spacer (#270) onto the output shaft as far as it will go. Install Key (#234), then slide the Optical Disc Assembly onto the output shaft, butting it up against the Spacer. (See Figure 6.8)

2. Tighten Set Screw (#154) and recheck the Hub position on the output shaft.
3. Apply a light coat of grease to the area on the Hub where the Dirt Seal (#269) rides.
4. If the Dirt Seal (#269) was removed then install it onto the Disc Housing (#17).
5. Attach the Disc Housing (#17) to the output end of the *Posidyne* with the (4) Screws (#76).
6. Place the Gasket (#19) on top of the Disc Housing.
7. Carefully insert the Circuit Board (#355) into the top of the Disc Housing making sure the (3) Photo Interrupters straddle the Optical Disc. (See Figure 6.8)

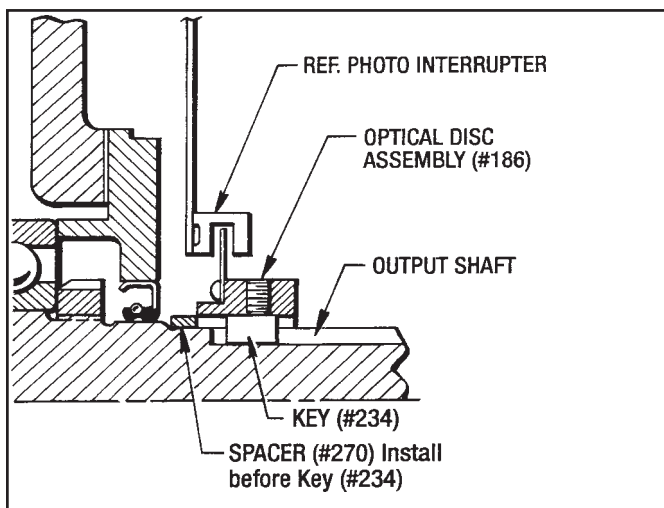

Figure 6.8 - Optical Disc and Hub Positioning

8. While holding the Circuit Board upright slide the Upper Enclosure (#18) down over the Circuit Board onto the Disc Housing. Make sure the edges of the Circuit Board are in the (2) side retaining slots located in the Upper Enclosure. (See Figure 6.9)

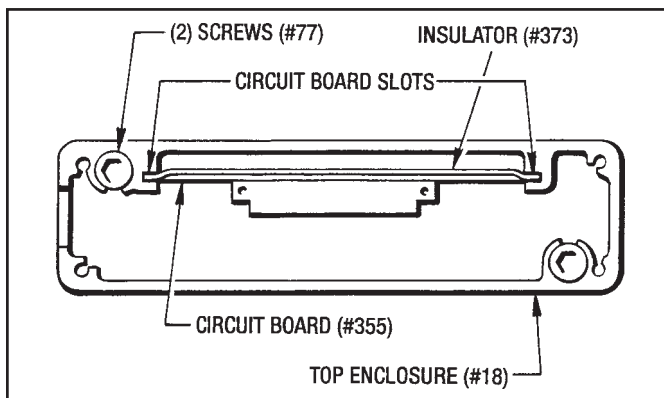

Figure 6.9 - Circuit Board Slots

9. Check the Gasket (#19) to see if it is still in place. Insert the (2) Screws (#77) and tighten down.
10. Slide the Insulator (#373) down and into the Upper Enclosure (#18) behind the Circuit Board (#355) placing the upper tabs into the circuit board slots.

11. Place the Cable Grommet (#260) and Cable (#259) into the upper slot and plug in the Cable Connector (#368) to the Circuit Board Connector.
12. Place the top Gasket (#19) on the Upper Enclosure and attach the Top Cover (#372) with (4) Screws (#225).

6-11 REMOVAL AND INSTALLATION OF MANIFOLD MOUNTED CONTROL VALVE

(See Figures 7.2 and 7.7)

A. VALVE REMOVAL

1. Disconnect the air hoses and the 4-Pin Brad Harrison Cable.
2. Unscrew (2) Screws (#305) and lift the Control Valve (#900) off of the Manifold (#298).
3. Check the O-Rings (#104) and replace if necessary.
4. Remove the Manifold (#298) by taking out (4) Screws (#370) and (4) Washers (#151).
5. Remove and discard Gasket (#54).

B. VALVE INSTALLATION

1. Install Gasket (#54) on the Output Housing.
2. Attach Manifold (#298) with the (4) Screws (#370) and (4) Washers (#151).
3. Place the O-Ring (#104) into the valve bottom ports.
4. Attach Valve (#900) to the Manifold (#298) with (2) Screws (#305).
5. Connect the 4-Pin Brad Harrison Cable and both air hoses .

6-12 REMOVAL AND INSTALLATION OF BRAKE RELEASE VALVE (#400)

(See Figure 7.2)

A. VALVE REMOVAL

1. Disconnect the 3-Pin Brad Harrison cable and both air lines.
2. Remove the (2) Screws (#466) and remove the Valve (#400) from the base frame.

B. VALVE INSTALLATION

1. Attach the Valve (#400) to the bottom of the base frame.
2. Connect the 3-Pin Brad Harrison cable and the (2) air lines.

6-13 REMOVAL OF STARWHEEL GEARBOXES

(See Figures 7.1 and 7.5)

1. Loosen the Collet Bolt (#843) to release the Collet (#823) from the Starwheel Shaft. Refer back to **Section 2-3 REMOVAL OF THE STARWHEEL SHAFT**

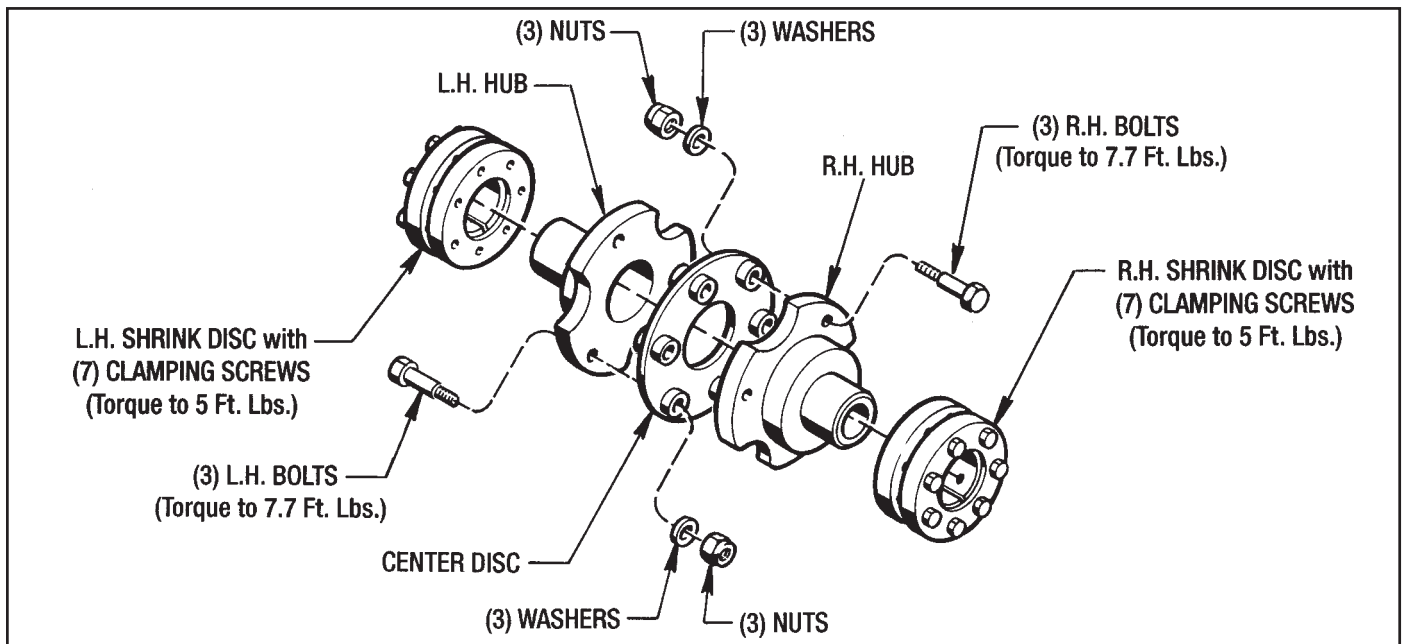

Figure 6.10 - Drive Coupling Elements

FROM THE GEARBOX COLLET and Figure 2-2 for this procedure.

2. Separate the Coupling (#747) (See Figure 6-10). **Only the (3) L.H. Bolts need to be removed to separate the Coupling Elements.**
3. Loosen the Drive Motor Mounting Nuts (#716) and release the tension on the Input Drive Belt (#714).
4. Loosen the Posidyne Hold down Bolts (#705) and with the Jackscrews (#781) release the tension on the Output Drive Belt (#742). Remove this Drive Belt (#742).
5. Remove the Gearbox Mounting Bolts (#704 and #780).
6. Lift the Gearbox off the base frame with an overhead hoist and sling.
7. The separated coupling elements can now be removed from each shaft by loosening the (7) Clamping Screws in each of the Shrink Discs. (See Figure 6.10)

If further Disassembly of either Gearbox is required go to **Section 6-15 STARWHEEL GEARBOX DISASSEMBLY.**

6-14 INSTALLING STARWHEEL GEARBOXES

(See Figures 7.1 and 7.4)

1. Place the L.H. Coupling Elements (L.H. Shrink Disc and the L.H. Hub) as far back as possible onto the keyless end of the Input Shaft (#11) in the L.H. Gearbox. Just hand tighten the (7) Clamping Screws in the Shrink Disc so it won't fall off the shaft. **Do not torque these screws yet.** (See Figure 6.10)
2. Place the R.H. Coupling Elements (Disc, R.H. Hub and

R.H. Shrink Disc) as far as possible onto the Input Shaft (#821) in the R.H. Gearbox. Again, only hand tighten the (7) Clamping Screws in the Shrink Disc. (See Figure 6.10).

3. Clean the mounting base surface where the Gearboxes are to be mounted.
4. Set the Gearboxes in position and install Mounting Bolts (#704) and Washers (#706). Only hand tighten these bolts at this time.

Install the bottom Mounting Bolts (#780) and Washers (#706). Tighten these bolts, being careful to keep the Gearbox snug against the back plate of the mounting base. Complete the tightening of Bolts (#704).

The Coupling Elements have to be aligned with each other and the Coupling has to be centered between the two Gearboxes. (See Figures 6.9 and 6.10)

THE ALIGNMENT PROCEDURE IS AS FOLLOWS:

- a. Loosen the (7) Clamping Screws in each of the Shrink Discs and slide the Coupling Elements together.
- b. Install the (3) L.H. Bolts, Washers and Nuts into the L.H. Hub and Disc. Carefully tighten all (6) Bolts alternately in a clockwise direction until all Screws are **torqued to 7.7 Lb. Ft.**
- c. Position the Coupling so that Dimension "A" is the same as Dimension "B". Use a straight metal scale to determine this. (See Figure 6.11)
- d. After the Coupling is centered, carefully **torque the Clamping Screws to 5 Lb. Ft.** in a circular pattern. Tighten slowly, going around at least 5 times.

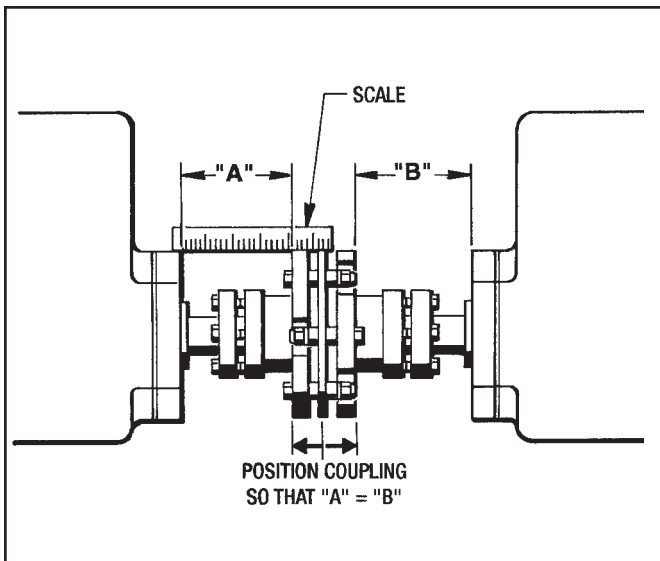

Figure 6.11 - Coupling Alignment

6-15 STARWHEEL GEARBOX DISASSEMBLY

(See Figure 7.5)

The Starwheel Gearbox Assembly consists of (2) Gearboxes. A L.H. Gearbox with a Dual Input Shaft and a R.H. Gearbox with a Single Input Shaft. The following procedure covers both Gearboxes.

Reference Numbers are assigned to each part in the Exploded View Drawings in Section 7. These Reference Numbers correspond to the Parts List for each Explode.

In most cases, unless the Drive is to be completely overhauled, should only be disassembled to the extent necessary to gain access to the worn or damaged parts. For Disassembly and Reassembly, follow the sequence of operation given in this section. **Note the specific points given in the instructions.**

Before Disassembly make a sketch of the Gearboxes showing the relationship of the Gear Shafts to the Gear Hub/Collet Assembly.

Remove the Drain Plug (#834) and drain the oil into an appropriate pan. After the oil is drained out, place the unit on a flat surface with the Collet facing down.

A. DUAL SHAFT GEARBOX

1. Remove the (4) Screws (#894) from the Bearing Retainer (#803) on the R.H. side of the Gearbox.
2. Use (2) of the screws as jackscrews to back the Bearing Retainer (#803) out of the Housing (#800).

NOTE:

The Bearing Cup of Bearing (#809) will remain in the Bearing Retainer (#803).

3. Remove and inspect O-Ring (#872) and Shim (#861) and place in a clean and dry location.

4. Remove the Key (#833) from the Dual Input Shaft (#820).
5. Pull the Dual Input Shaft (#820) out of the R.H. side of the gearbox housing.

NOTE:

The (2) Bearing Cones of Bearings (#808) and (#809) and the (2) Wear Sleeves (#875) will remain on the shaft.

6. Remove the (4) Screws (#894) from the Bearing Retainer (#803) on the other end of the Gearbox Housing.
7. As before, use (2) of the Screws (#894) as jackscrews to back the Bearing Retainer (#803) out of the Housing (#800).

NOTE:

The Bearing Cup of Bearing (#808) will remain in the Bearing Retainer (#803).

8. Remove and inspect the O-Ring (#872) and the Shim (#861) from the Bearing Retainer. Store in a clean and dry place.
9. Turn the Gearbox over and remove the (6) Screws (#892) from the Bearing Retainer (#804).
10. Use (2) of these screws as jackscrews to back this Bearing Retainer (#804) out of the housing.

NOTE:

The Bearing Cup of Bearing (#811) will remain in the Bearing Retainer (#804).

11. Remove and inspect Shim (#860) from the Bearing Retainer (#804) and keep in a clean dry location.
12. Remove the Gear Hub (#819) from the Gearbox Housing (#800).

NOTE:

The Bearing Cones of both Bearings (#810) and (#811) will stay on the Gear Hub (#819) and the Bearing Cup of Bearing (#810) will stay in the Housing.

B. SINGLE SHAFT GEARBOX

1. Remove the (4) Screws (#894) from the Bearing Retainer (#803) on the L.H. side of the Gearbox.
2. Use (2) of the screws as jackscrews to back the Bearing Retainer (#803) out of the Housing (#800).

NOTE:

The Bearing Cup of Bearing (#808) will remain in the Bearing Retainer (#803).

3. Remove and inspect O-Ring (#872) and Shim (#861) and place in a clean and dry location.
4. Pull the Single Input Shaft (#821) out of the L.H. side of the gearbox housing.

NOTE:

The (2) Bearing Cones of Bearings (#808) and (#809) and the (2) Wear Sleeves (#875) will remain on the shaft.

5. Remove the (4) Screws (#894) from the Bearing Retainer (#803) on the other end of the Gearbox Housing.
6. As before, use (2) of the Screws (#894) as jackscrews to back the Bearing Retainer (#803) out of the Housing (#800).

NOTE:

The Bearing Cup of Bearing (#809) will remain in the Bearing Retainer (#803).

7. Remove and inspect the O-Ring (#872) and the Shim (#861) from the Bearing Retainer. Store in a clean and dry place.
8. Turn the Gearbox over and remove the (6) Screws (#892) from the Bearing Retainer (#804).
9. Use (2) of these screws as jackscrews to back this Bearing Retainer (#804) out of the housing.

NOTE:

The Bearing Cup of Bearing (#811) will remain in the Bearing Retainer (#804).

10. Remove and inspect Shim (#860) from the Bearing Retainer (#804) and store in a clean dry location.
11. Remove the Gear Hub (#819) from the Gearbox Housing (#800).

NOTE:

The Bearing Cones of both Bearings (#810) and (#811) will stay on the Gear Hub (#819) and the Bearing Cup of Bearing (#810) will stay in the Housing.

C. REMOVAL OF BEARINGS

IMPORTANT

Bearings should only be replaced after close inspection for damage and wear in both the Cone and the Cup. Do not remove them if replacement is not necessary.

1. Using a bearing puller, remove the (2) Bearing Cones of Bearings (#808) and (#809) from Shafts (#820) and (#821).

NOTE:

The (2) Wear Sleeves (#875) will also be pressed off the shafts when the Bearing Cones are pressed off.

2. Use an inside bearing puller with a slide hammer to remove the Bearing Cup of Bearing (#808) from the Bearing Retainer (#803). Repeat this operation for the other Bearing Cup (#809).

3. With a bearing puller, remove the (2) Bearing Cones (#810) and (#811) from the Gear Hubs (#818) and (#819)
4. Use an inside bearing puller with a slide hammer to remove the Bearing Cup of Bearing (#811) from the Bearing Retainer (#804). Repeat this operation for the other Bearing Cup (#810) located in the Housing.

D. OIL SEAL REMOVAL

IMPORTANT

Only remove the Oil Seals (#824) and (#825) if they are damaged and have to be replaced.

1. With an Arbor Press remove Oil Seal (#824) from the Bearing Retainer (#803).
Repeat the same operation for Oil Seal (#825) in the Bearing Retainer (#804).

E. WEAR SLEEVE REMOVAL

1. Removal of the (2) Wear Sleeves (#875) from both Input Shafts (#820) and (#821) is accomplished by pulling the Bearing Cones (#808) and (#809) off with a bearing puller.
2. Use the following procedure to remove the Wear Sleeve (#874) from the Gear Hub (#818) or (#819).
(See Figure 6.12)

With a chisel the same width as the Wear Sleeve make about 5 or 6 notches in the Wear Sleeve. The Wear Sleeve (#874) can now be removed by hand.

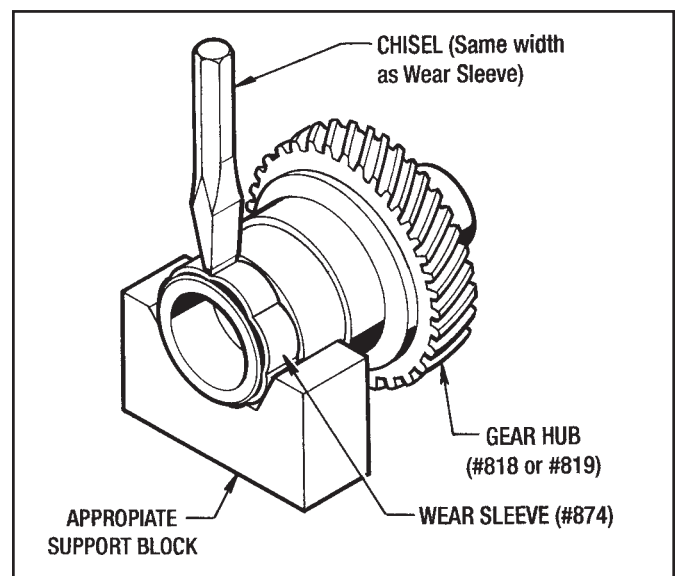

Figure 6.12 - Removing Wear Sleeve (#874)

6-16 CLEANING AND INSPECTION

WARNING

Petroleum based cleaning solvents are flammable, and open flames or smoking by any personnel in the vicinity of these solvents is extremely dangerous and must not be permitted.

A. CLEANING AND INSPECTION

Clean metal parts in a suitable solvent and dry with a stream of low pressure compressed air. After cleaning, inspect parts for cracks, distortion, scoring, nicks, burrs or any other damage that would affect serviceability. Pay particular attention to the following:

1. Inspect closely the Wear Sleeves (#874) and (#875) and shafts in the area of the Oil Seals (#824) and (#825). Check for nicks, scratches or any other damage that could cause leakage. Replace any damaged parts.
2. It is not necessary to remove the Roller Bearings to check their operation. Slowly rotate the Cup or Cone by hand, checking to see if it rotates freely without rough or flat spots.

B. REPAIR AND REPLACEMENT

A fine stone or crocus cloth should be used to remove minor surface defects from parts so long as the operating or sealing action of the part is not affected. The use of coarser abrasives or other machining methods should not be used. Otherwise, all damaged parts must be replaced. Replacement is recommended for all O-Rings, Liners, Oil Seals and Bearings during the course of Disassembly.

6-17 STARWHEEL GEARBOX REASSEMBLY

(See Figure 7.4)

A. GENERAL REASSEMBLY INSTRUCTIONS

1. Lubricate O-Rings and the lips of Oil Seals with a white grease before reassembly and installation of mating parts.
2. The installation of press-fitted parts are eased by heating the outside parts in an oven. Heat Bearings to 250° maximum.

B. GEAR HUB ASSEMBLY

1. Place a light coat of Gasket Sealant (Permatex #30) in the seal bore of the Bearing Retainer (#804), immediately before pressing the Oil Seal (#825) into the Bearing Retainer.
2. Place a light coating of Loctite (Green #680) on the outside diameter of the Bearing Cup (#811) and press into the Bearing Retainer (#804).

3. Place a light coating of Loctite (Green #680) on the outside diameter of the Bearing Cup (#810) and press into the Gearbox Housing (#800).
4. Press Bearing Cone (#810) onto the Gear Hub (#818) and (#819).
5. Press Bearing Cone (#811) onto the Gear Hub (#818) and (#819).
6. Apply a light coating of Loctite (Red #271) on the inside diameter of the Wear Sleeve (#874) and press onto the Gear Hub (#818) and (#819). Use an Arbor Press and appropriate support tooling.
7. Lay the Gearbox Housing (#800) on a flat surface with the opening for the Gear Hub face up. Place the Gear Hub Assembly into the Housing until the Bearing Cup and Cone (#810) seat properly.
8. Place the Bearing Retainer (#804) onto the Gear Hub Assembly and tighten down with (6) Screws (#892).
9. Using a Feeler Gauge determine the thickness of Shims (#860) by taking the measured thickness and adding 0.007" thickness in shims. (See Figure 6.10).
10. Remove the Screws (#892) and Bearing Retainer (#804) from the Housing.
11. Spray Shims with Copper Coat (K&W Products Inc. Stock #612).
12. Place the Shims (#860) onto the Bearing Retainer (#804) and place the whole assembly onto the Gear Hub and tighten down with (6) Screws (#892). Use Loctite (Blue #242) on the screws.

C. INPUT GEAR SHAFT ASSEMBLY (Single and Dual Input Shaft)

1. Place a light coat of Gasket Sealant (Permatex #30) in the seal bore of the (3) Bearing Retainers (#803) and press the Oil Seal (#824) into them.
2. Place a light coat of Loctite (Red #271) on the outside diameter of the Freeze Plug (#828) and press it into the remaining Bearing Retainer (#803).
3. Place a light coating of Loctite (Green #680) on the outside diameter of the (2) Bearing Cups (#808) and press them into (2) of the Bearing Retainers (#803).
4. Place a light coating of Loctite (Green #680) on the outside diameter of the (2) Bearing Cups (#809) and press, them into the other (2) Bearing Retainers (#803).
5. Lubricate the (4) O-Rings (#872) and install them on all (4) Bearing Retainers (#803).
6. Install 0.015" (2-Piece) Shims (#861) on all (4) of the Bearing Retainers (#803).

NOTE:

The Bearing (#809) is the larger of the (2) Tapered Roller Bearing Assemblies

7. Press the Bearing Cone (#809) onto the cut-off end of the Gear Shaft (#821).
8. Press the Bearing Cone (#808) onto the extended end of the Gear Shaft (#821).
9. Press Bearing Cone (#809) onto the non key way end of Shaft (#820).
10. Press Bearing Cone (#808) onto the key way end of Shaft (#820).
11. Apply a light coat of Loctite (Red #271) on the inside diameter of the Wear Sleeves (#875) and press them onto both Input Gear Shafts (#820) and (#821). Use an arbor press with appropriate support tooling.

D. SINGLE INPUT GEAR SHAFT INSTALLATION

1. Bolt down Bearing Retainers (#803) that has an Oil Seal (#824) and .015" Shims (#861) installed into the Housing (#800) with Screws (#894). Use Loctite (Blue #242) on these Screws.

CAUTION

Check the shaft orientation versus the sketch made of the Gear Boxes before Disassembly.

2. Wrap electrical tape around the leading edge of the Wear Sleeve (#875).
3. Lubricate the Oil Seal Lip (#824) with white grease. Slide the Gear Shaft Assembly into the Housing past the Gear Hub and into the Oil Seal until the Bearing Cup and Cone (#808) seat properly. Be careful not to damage the Oil Seal (#824) on the Wear Sleeve.
4. Install the Bearing Retainer (#803) that has the Freeze Plug (#828) in it, but without Shims (#861) onto the Housing (#800) with (4) Screws (#894).

5. Using a feeler gauge, determine the thickness of shims needed. Then add .003" to .005" additional shims for appropriate bearing end play. (See Figure 6.13).

Remove the Bearing Retainer (#803) and install the required Shims (#861).

Re-attach the Bearing Retainer with the Shims installed on it with the (4) Screws (#894). Use Loctite (Blue #271) on the Screws.

6. Remove the electrical tape from the Wear Sleeves.

E. DUAL INPUT GEAR SHAFT INSTALLATION

1. Bolt down Bearing Retainers (#803) that has an Oil Seal (#824) and .015" Shims (#861) installed into the Housing (#800) with Screws (#894). Use Loctite (Blue #242) on these Screws.
2. Wrap electrical tape around the leading edge of both Wear Sleeves (#875).
3. Cover the keyway of the Gear Shaft (#820) with electrical tape.

CAUTION

Check the shaft orientation versus the sketch made of the Gear Boxes before Disassembly.

4. Lubricate the Oil Seal Lip (#824) with white grease. Slide the Gear Shaft Assembly into the Housing past the Gear Hub and into the Oil Seal until the Bearing Cup and Cone (#808) seat properly. Be careful not to damage the Oil Seal (#824) on the Wear Sleeve lip.
5. Install the remaining Bearing Retainer (#803), but without Shims (#861) over the gear shaft extension onto the Housing (#800) with (4) Screws (#894). Do not damage the Oil Seal with the wear sleeve lip

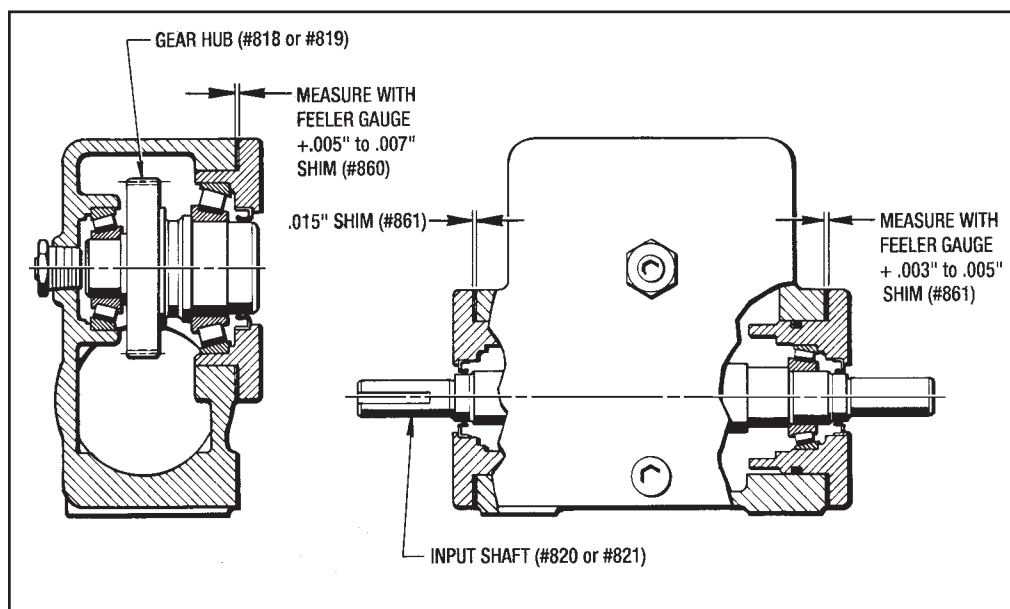

Figure 6.13 - Determining Shim Thickness of Bearing Retainers

6. Using a feeler gauge, determine the thickness of shims needed then add .003" to .005" additional shims for appropriate bearing end play. (See Figure 6.10).

Remove the Bearing Retainer (#803) and install the required Shims (#861).

Re-attach the Bearing Retainer with the Shims installed on it with the (4) Screws (#894). Use Loctite (Blue #271) on the screws.

6. Remove the electrical tape from the Wear Sleeves and the Keyway.

6-18 OPERATIONAL CHECKS

Turn the Gear Shafts by hand and watch the rotation of the Gear Hub.

6-19 FINAL REASSEMBLY

1. Slide the Collet (#823) into the Gear Hub. Insert the Screw (#843) and Seal Washer (#826) through the housing and into the Collet. (**Torque to 85 Ft. Lbs.**)
2. Replace all pipe plugs and fittings removed during inspection and disassembly.
3. Fill the Gearbox with Mobilube HD-80W90, or equivalent, until the oil starts to come out the pipe tap where the Pipe Plug (#835) was installed. Replace Pipe Plug (#835).

6-20 REPLACING CIRCUIT BOARDS

(See Figure 6.14)

A. Power Supply Board

1. Disconnect the Terminal Strip Connectors #J1, #J2, #J3, #J4, #J5 and the Flat Wire Connector.

NOTES:

1. Pull down to unplug #J1 to #J4. and pull up to unplug #J5.

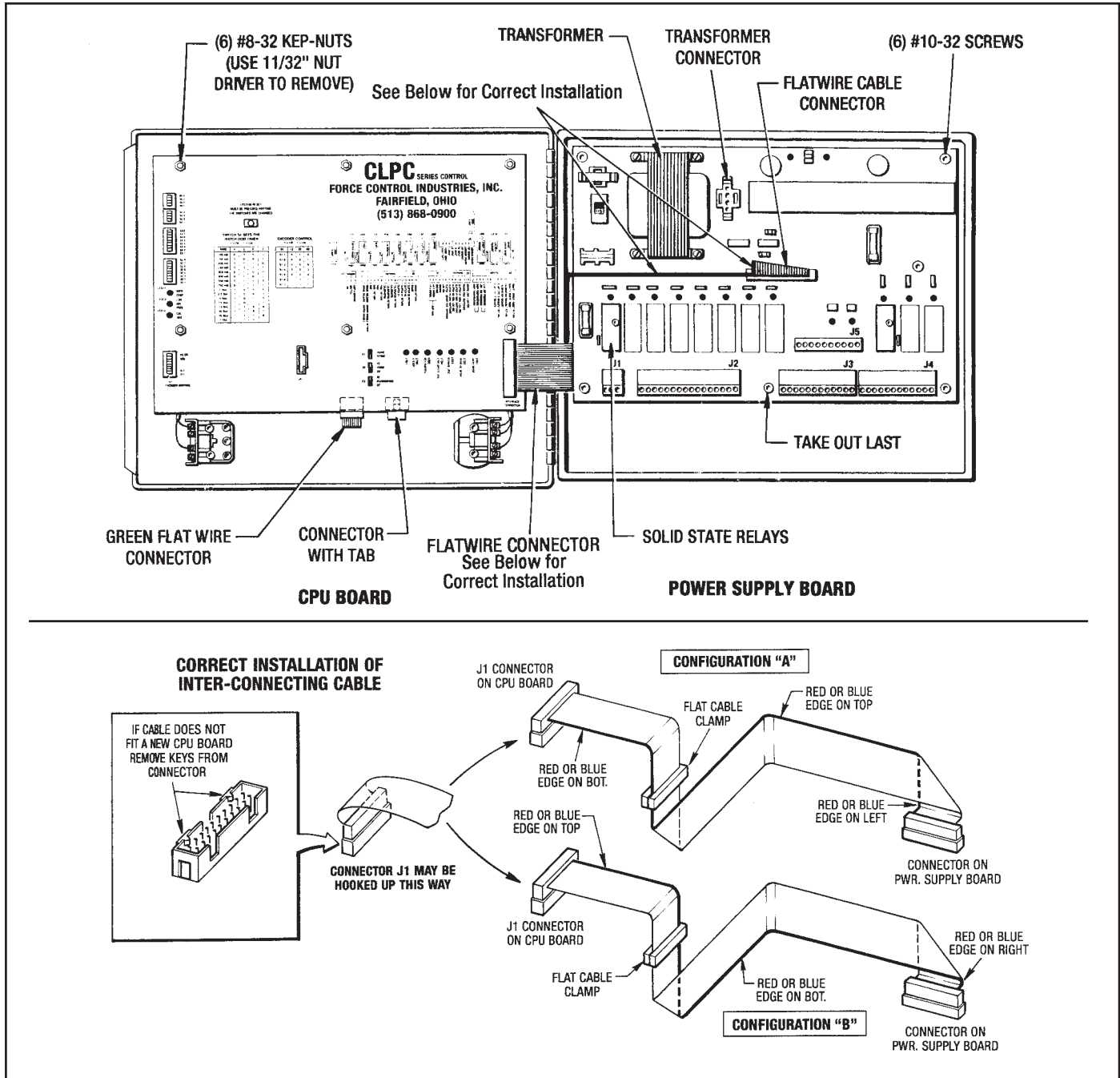

Figure 6.14 - Replacing Circuit Boards

2. There are release tabs on the ends of the Flat Wire Connector. Pull the tabs out and pull up on the connector to unplug it.
2. Disconnect the Transformer Connector by squeezing the end tabs and pulling it up.
3. Remove the (4) #10-32 Phillips Head Screws from the Transformer and pull it off the board.
4. Take the (6) #10-32 Phillips Head Screws out of the Power Supply Board, leaving the bottom middle screw until last. Remove the Power Supply Board from the control box.

To Reinstall a new Power Supply Board just reverse these steps. Put the bottom middle screw in first and proceed.

B. CPU Board

1. Unplug the Flat Wire Connector from the bottom right hand corner of the CPU Board.
2. Remove the (6) #8-32 Kep-Nuts with a 11/32" Nut Driver.
3. Unplug the two remaining Connectors at the bottom of the CPU Board.

NOTES:

1. The connector on the right hand side has a release tab. Push the tab to unplug the connector.
2. The connector on the left is a pull-off type and has no release tabs. **Be very careful not to crimp or bend the flat wire cable when unplugging this connector.**
5. The CPU Board can now be removed from the control box.

To reinstall a new CPU Board, just reverse the removal procedure.

WARNING

Please pay close attention to the instructions and diagrams shown in Figure 6.14 on how to install the Inter-Connecting Flat Wire Cable correctly. If the Cable Connector for the CPU Board is not plugged in properly, the CPU Board will be damaged when power is restored.

Section 7 ORDERING REPAIR PARTS

7-1 GENERAL INFORMATION

This section illustrates, lists and describes all available Repair Parts for the Force Control Auto Catcher Drive. Exploded views with numbers are used to identify the various parts in the Drive Unit. These numbers are listed in the parts list along with the part name and quantity used.

7-2 FACTORY RE-BUILD SERVICE

Re-conditioning service is offered by Force Control Industries at the factory. Before returning a unit for this service, be sure to first contact the Force Control Industries Service Sales Dept. for authorization and shipping instructions. Force Control Industries cannot be responsible for units returned to the factory without prior notice or authorization.

Care must be given to the packaging of returned drives. Always protect mounting feet by attaching to a skid. Shipment-damaged drives always delay repairs. When possible, describe the problem experienced on your shipping papers.

SHIPPING ADDRESS: Force Control Industries, Inc.
3660 Dixie Highway
Fairfield, Ohio 45014
Telephone: (513) 868-0900
Fax: (513) 868-2105

7-3 DRIVE MOTORS

The motors used with these Drive Units are standard and may be repaired or replaced by any qualified motor rebuild facility or supplier.

7-4 ORDERING REPAIR PARTS

When ordering replacement parts, please specify all of the following information:

1. Drive Model Number (on the nameplate).
2. Drive Serial Number (on the nameplate).
3. Part Reference Number.
4. Part Name.
5. Quantity.
6. Complete shipping Information.

Failure to include information for items 1 through 6 will only delay your parts order. Unless another method is specified for item 6, parts less than 70 pounds will be shipped United Parcel Service, parts over 70 pounds will be shipped motor freight. Air freight and other transportation services are available, but only if specified on your order.

AUTO-CATCHER ASSEMBLY
(Figure 7.1)

REF No.	PART NAME	QTY.	REF.. No.	PART NAME	QTY.
700	Mounting Base	1	716	Hex Nut, 5/8"-18	4
701	Adjustable Motor Base	1	728	Lockwasher, 5/16"	8
703	Hex Nut, 3/8"-16	4	731	Hex Hd. Cap Screw	4
704	Hex Hd. Cap Screw	4	733	Hex Nut, 5/16"-18	3
705	Hex Hd. Cap Screw	4	738	Gates Poly Chain Pulley	2
706	Lockwasher, 1/2"	8	740	Bushing, Woods, 1-3/8" Bore	1
707	Lockwasher, 3/8"	4	741	Bushing, Woods, 7/8" Bore	1
710	Gates Poly Chain Pulley	1	*742	Gates Belt	1
711	Gates Poly Chain Pulley	1	747	Flexible Coupling	1
712	Bushing, Woods, 1-3/8" Bore	1	749	Flat Washer, 3/8"	4
713	Bushing, Woods, Type SDS 7/8" Bore	1	780	Hex Hd. Cap Screw	4
*714	Gates Poly Chain Belt	1	781	Hex Hd. Cap Screw	3

* - Indicates parts in Minor Overhaul Kit

AUTO-CATCHER ASSEMBLY

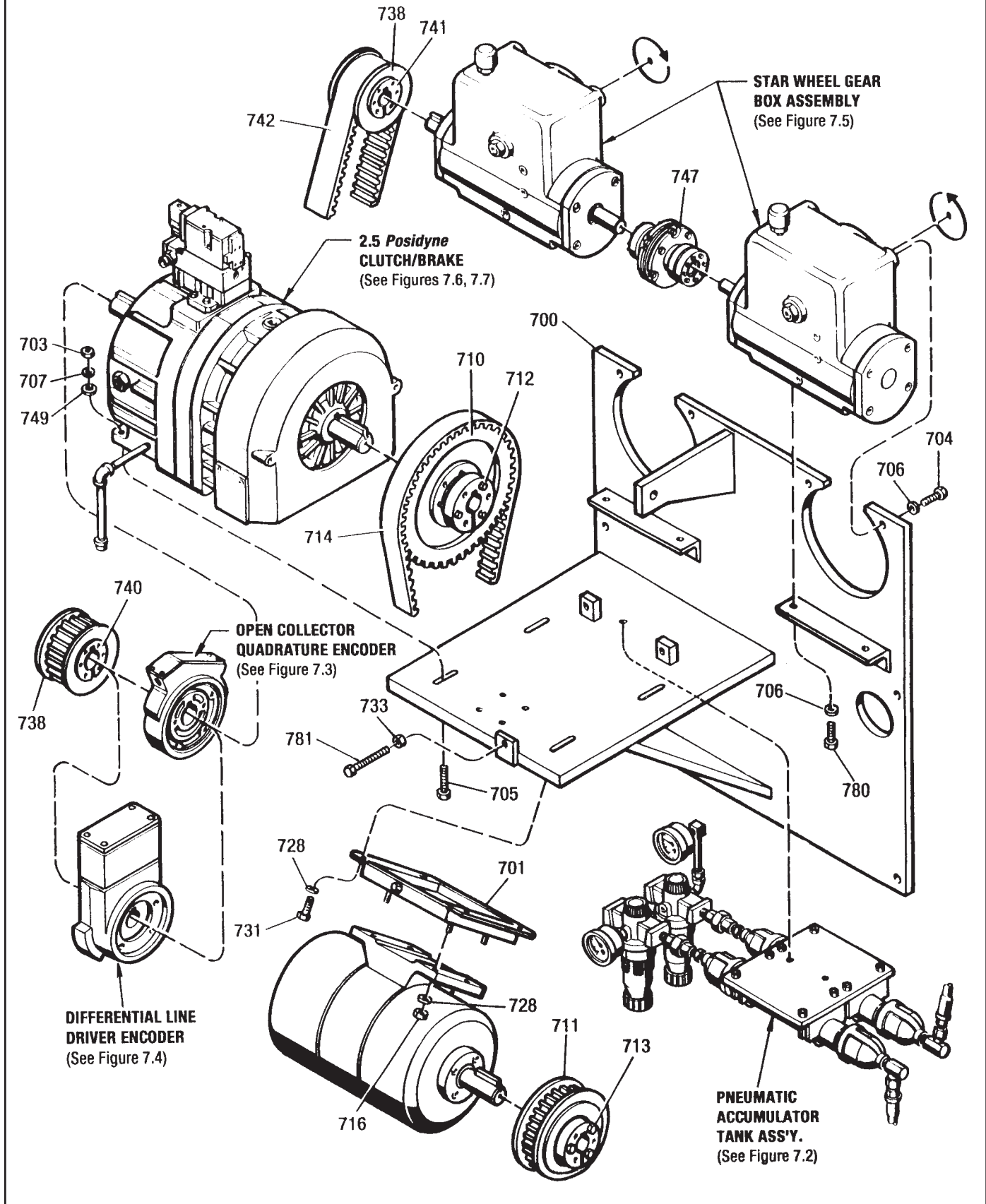

Figure 7.1 - Auto Catcher Assembly

FORCE CONTROL INDUSTRIES, INC.



MEX (55) 53 63 23 31 MTY (81) 83 54 10 18
 QRO (442) 1 95 72 60 ventas@industrialmagza.com

PNEUMATIC ACCUMULATOR TANK ASSEMBLY
(Figure 7.2)

REF No.	PART NAME	QTY.	REF No.	PART NAME	QTY.
400	Mac Valve	1	436	Pipe Nipple, 1-1/2" NPT x 10" lg.	2
401	Drain Cock	2	437	Bell Reducer, 1-1/2" x 1/2"	4
405	Watts Air Regulator	2	438	Reducer Bushing, 1/2" x 3/8"	2
406	Bronze Muffler	1	439	Pipe Nipple, 3/8" NPT Close	4
407	Pressure Gauge	2	440	90° Street Elbow, 3/8" NPT	1
410	Hose	2	441	90° Straight Elbow, 1/8" NPT	1
411	Hose	1	442	Pipe Union, 3/8" NPT	2
412	Plastic Tubing	2	443	90° Street Elbow, 1/4" NPT	1
421	Swivel Adapter	2	444	Reducer Bushing, 1/4" x 1/8"	2
422	Swivel Adapter	1	461	Base Plate	1
423	Hose Fitting	4	465	Hex Hd. Cap Screw	2
424	Push Connector, Straight Male	2	466	Soc. Hd. Cap Screw	2
425	Push Connector, 90° Male	2	481	Lockwasher, 3/8"	2
426	Hose Fitting	2	496	U-Bolt Clamp	4
427	90° Adapter	1			

PNEUMATIC ACCUMULATOR TANK ASSEMBLY

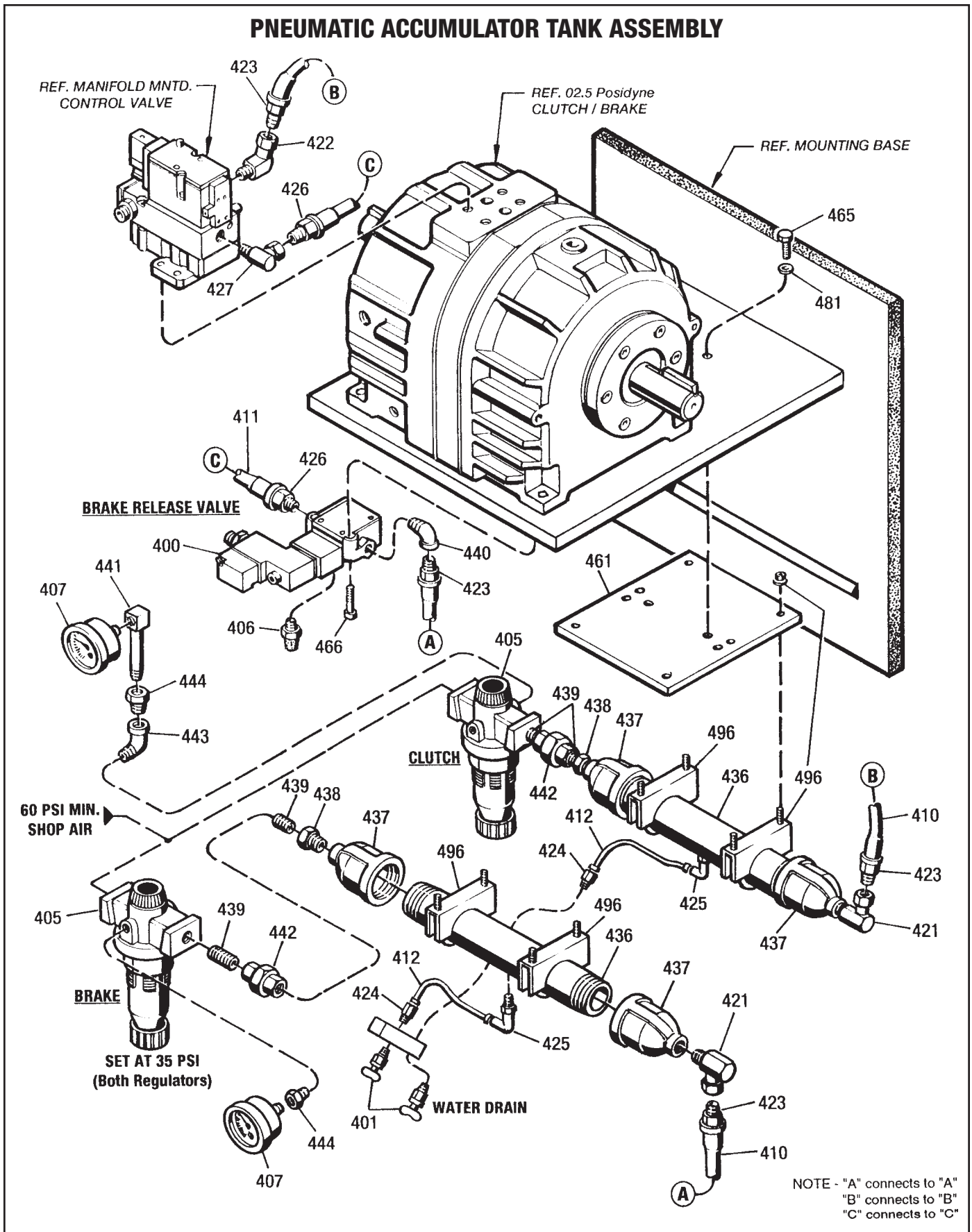

Figure 7.2 - Pneumatic Accumulator Tank Assembly

FORCE CONTROL INDUSTRIES, INC.



MEX (55) 53 63 23 31 MTY (81) 83 54 10 18
 QRO (442) 1 95 72 60 ventas@industrialmagza.com

OPEN COLLECTOR QUADRATURE ENCODER

(Figure 7.3)

REF No.	PART NAME	QTY.	REF No.	PART NAME	QTY.
17	Magnetic Pickup Housing	1	241	Soc. Set Screw	1
22	Magnetic Pickup	1	253	Magnetic Pickup Housing Cover	1
76	Soc. Hd. Cap Screw	4	257	Lockwasher	4
154	Set Screw	1	259	Cable, 5 Pin Straight, 5' Lg.	1
186	Pulse Gear	1	268	Button Hd. Cap Screw	4
*214	Shim	AR	355	Quadrature Pickup	1
225	Button Hd. Cap Screw	4	368	Receptacle, 5 Pin	1
226	Rd. Hd. Machine Screw	2	372	Top Cover	1
234	Key	1			

* - Indicates parts in Minor Overhaul Kit

AR - As Required

DIFFERENTIAL LINE DRIVER ENCODER

(Figure 7.4)

REF No.	PART NAME	QTY.	REF No.	PART NAME	QTY.
17	Disc Housing	1	259	Cable	1
18	Upper Enclosure	1	260	Cable Grommet	1
19	Gasket	2	269	Dirt Seal	1
76	Screw	4	270	Spacer (2.5 Posidyne Only)	1
77	Screw	2	355	Circuit Board	1
154	Set Screw	1	356	Jumper	1
186	Optical Disc Assembly	1	368	Cable Connector	1
225	Screw	4	372	Top Cover	1
234	Key	1	373	Insulator	1

OPEN COLLECTOR QUADRATURE (MAGNETIC) ENCODER

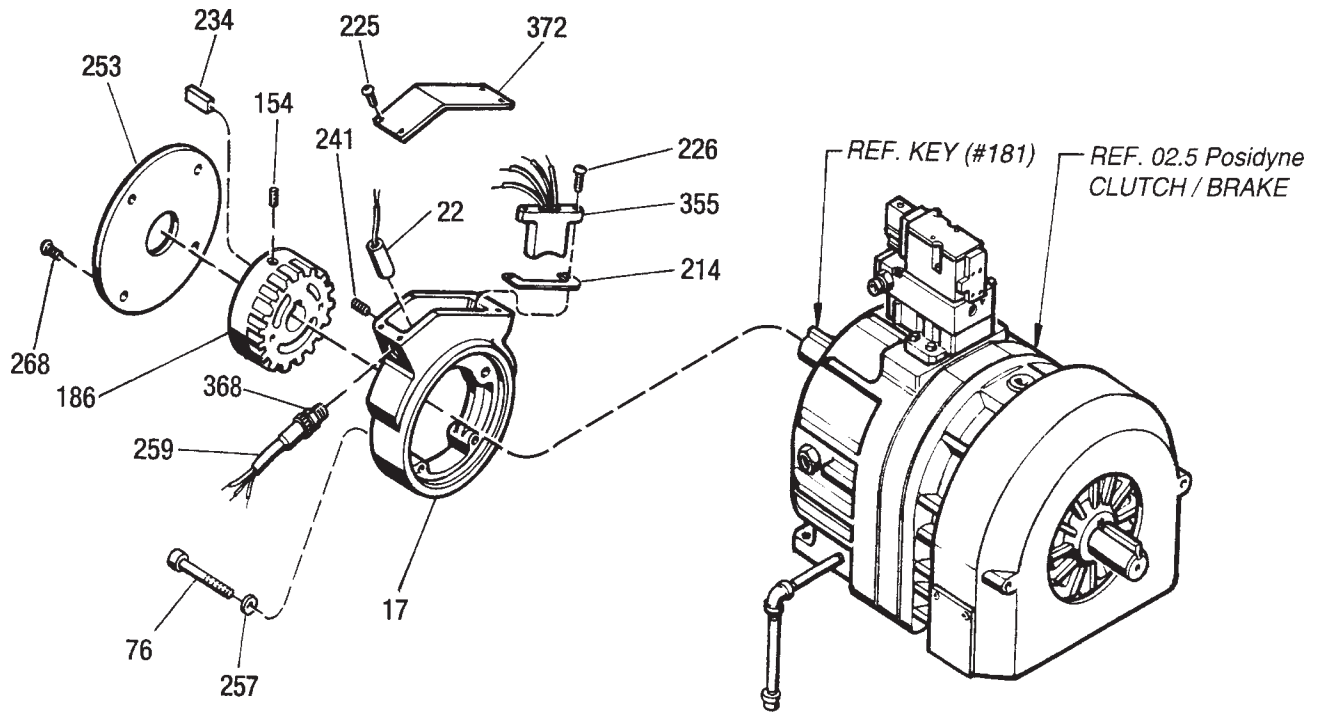

Figure 7.3 - Open Collector Quadrature (Magnetic) Encoder

DIFFERENTIAL LINE DRIVER (OPTICAL) ENCODER

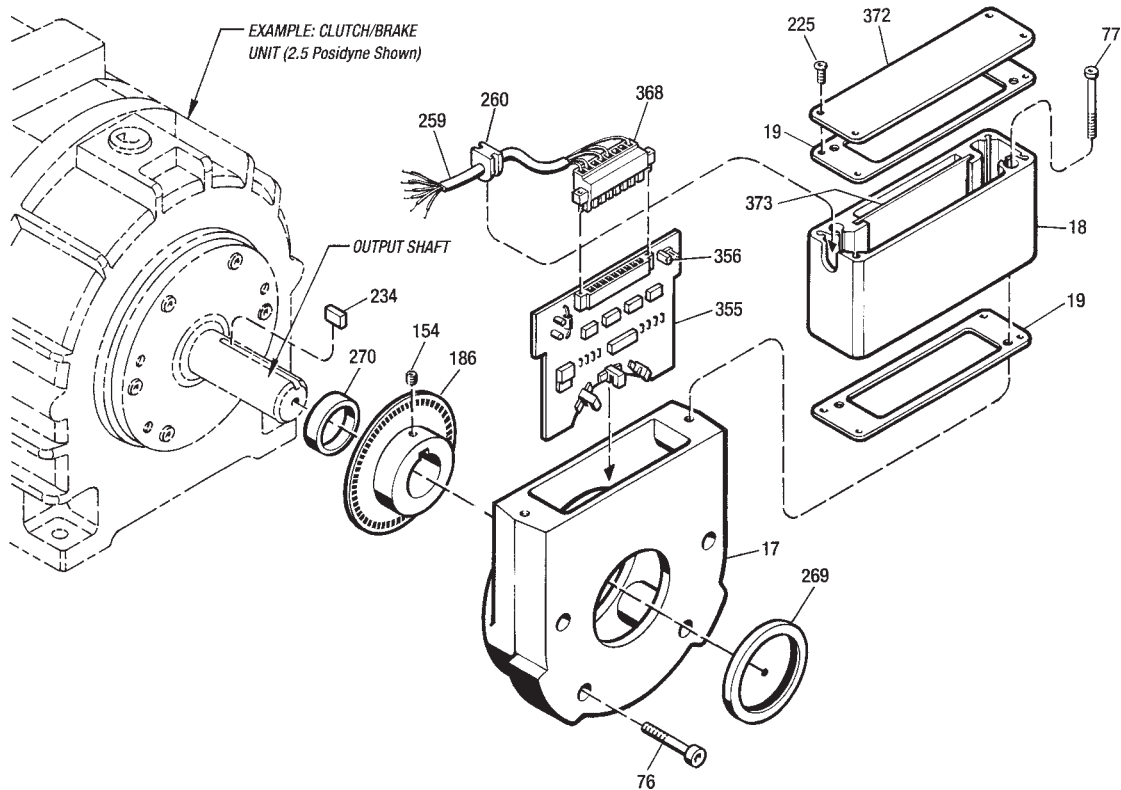

Figure 7.4 - Differential Line Driver (Optical) Encoder

STARWHEEL GEARBOX ASSEMBLY

(Figure 7.5)

REF No.	PART NAME	QTY.	REF No.	PART NAME	QTY.
800	Main Housing	2	828	Freeze Plug	1
803	Bearing Retainer	4	830	Pipe Plug	2
804	Bearing Retainer	2	**832	Oil Breather	2
*808	Timkin Bearing Assembly	2	833	Key	1
*809	Timkin Bearing Assembly	2	834	Pipe Plug, 1/2" NPT	2
810	Roller Bearing Assembly	2	835	Pipe Plug, 3/8" NPT	4
811	Roller Bearing Assembly	2	836	Reducer Bushing	2
818	Output Shaft, RH Helical	1	843	Soc. Hd. Cap Screw	2
819	Output Shaft, LH Helical	1	*860	Shim	2
820	Dual Input Gear Shaft	1	*861	Shim	4
821	Single Input Gear Shaft	1	*872	O-Ring	4
823	Collet, 1" Dia. Shaft	2	*874	Wear Sleeve	2
*824	Oil Seal	3	*875	Wear Sleeve	3
*825	Oil Seal	2	892	Low Hd. Cap Screw	12
*826	Dyna-Seal	2	894	Low Hd. Cap Screw	16

* - Indicates parts in Minor Overhaul Kit

** - Indicates parts in Major Overhaul Kit. (Plus all parts in Minor Overhaul Kit)

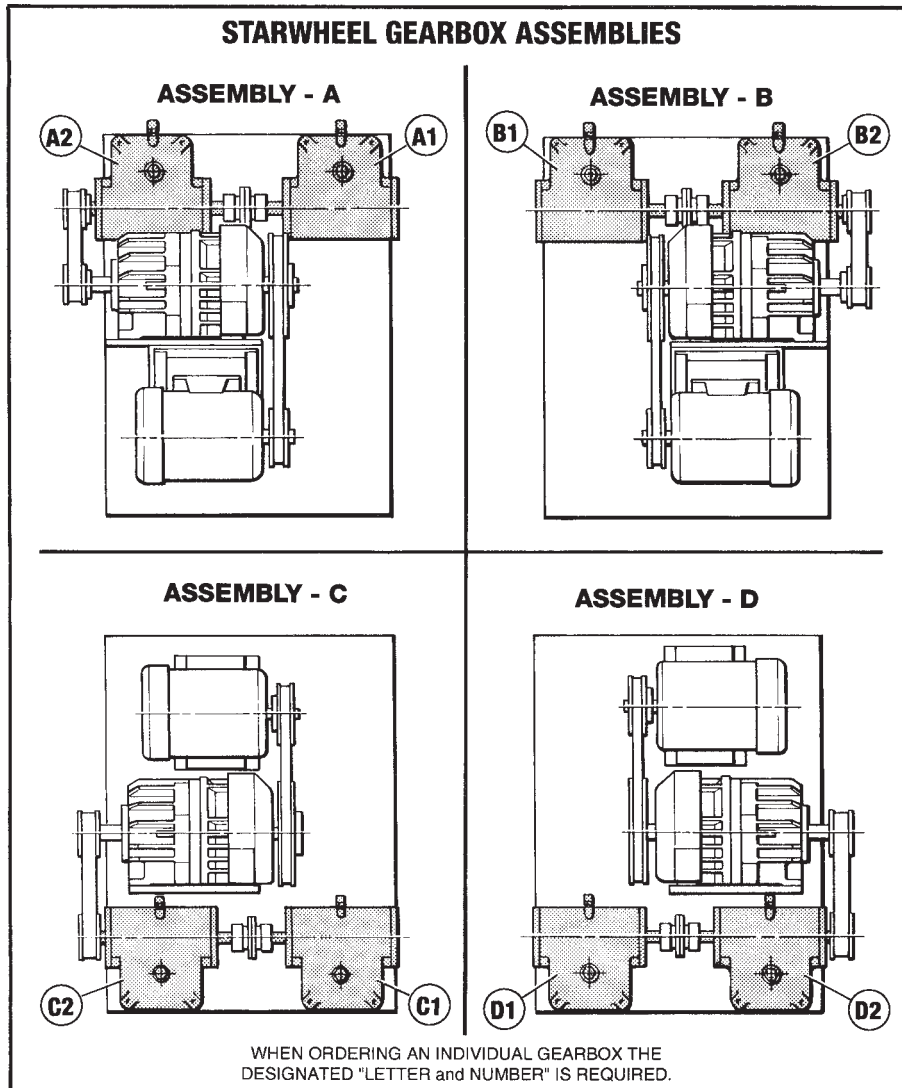

STARWHEEL GEARBOX ASSEMBLY

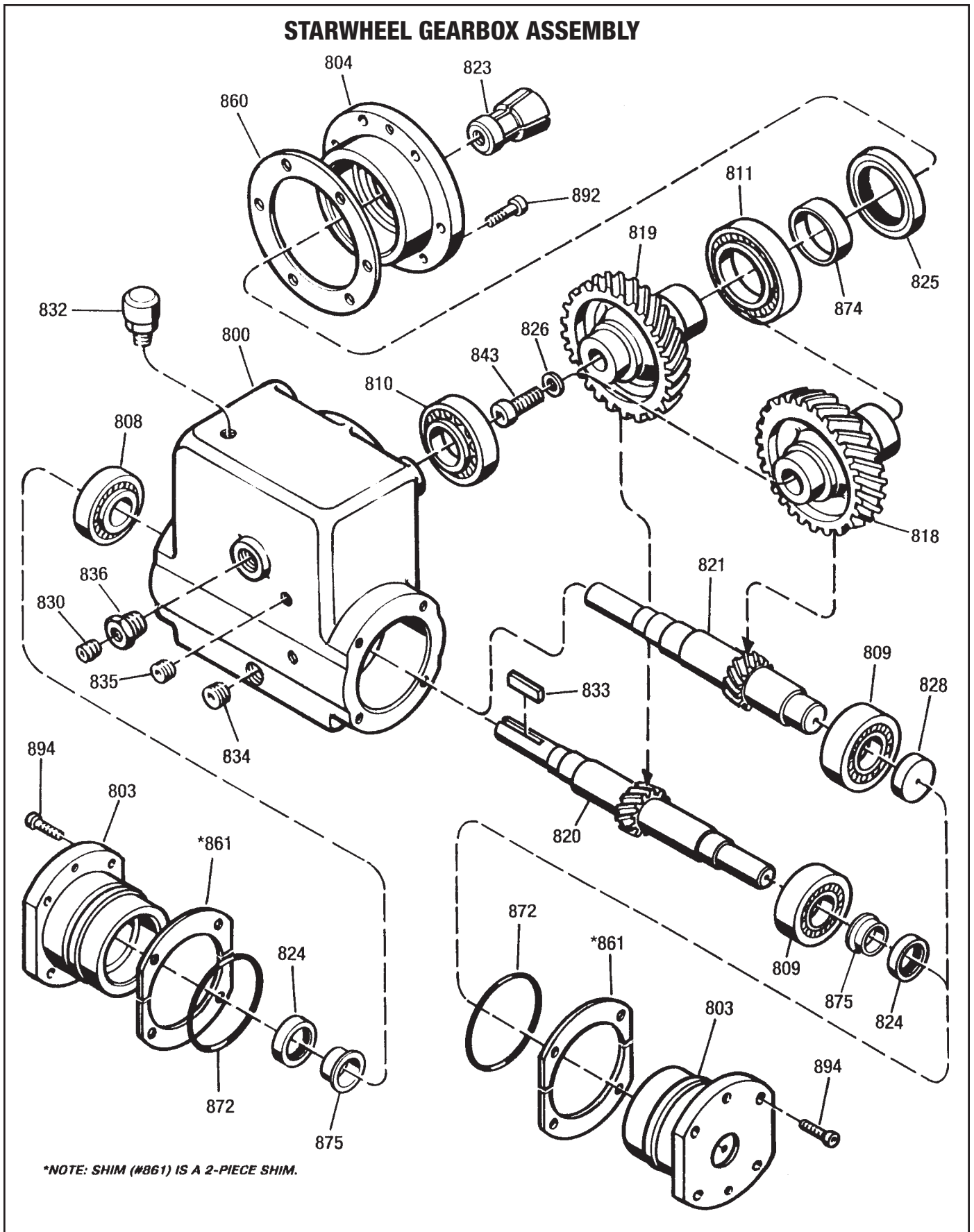

Figure 7.5 - Starwheel Gearbox Assembly

FORCE CONTROL INDUSTRIES, INC.



MEX (55) 53 63 23 31 MTY (81) 83 54 10 18
 QRO (442) 1 95 72 60 ventas@industrialmagza.com

2.5 Posidyne® CLUTCH and BRAKE UNIT (Figures 7.6 and 7.7)

REF No.	PART NAME	QTY.	REF No.	PART NAME	QTY.
1	Output Shaft	1	*55	Gasket, Bearing Retainer	2
2	Input Shaft	1	62	Soc. Hd. Cap Screw	4
3	Piston	1	63	Soc. Hd. Cap Screw	12
**5	Thrust Plate, Clutch	1	64	Soc. Hd. Cap Screw	4
7	Bearing Retainer	1	66	Soc. Hd. Cap Screw	2
8	Input Housing	1	68	Dowel Pin	2
9	Output Housing	1	69	Soc. Hd. Cap Screw	10
11	Piston Retainer	1	70	Set Screw	2
*12	Friction Disc	7	72	Pipe Plug, 1/2" NPT	1
*13	Drive Plate	8	73	Pipe Plug, 1/4" NPT	2
14	Pipe Plug, 1" NPT	2	74	Pipe Plug, 1/4" NPT	1
16	Bearing Retainer	1	90	Reducer Bushing	1
24	Fan Shroud	1	**97	Brake Pressure Plate	1
25	Fan	1	*104	O-Ring	2
*26	Bearing	1	122	Dowel Pin	2
*27	Bearing	1	127	Lockwasher	10
*28	Bearing	1	128	Lockwasher	4
*31	Oil Seal	2	136	Pipe Nipple	2
**34	Locknut	2	137	Pipe Elbow	1
*35	Bearing	1	138	Pipe Cap	1
37	Key	1	151	Lockwasher	2
*38	Bearing	1	152	Self Tapping Screw	4
*39	O-Ring	2	180	Key, Input Shaft	1
*40	O-Ring	2	181	Key, Output Shaft	1
*42	Liner, I.D. Sealing	2	185	Bolt Access Cover	2
*43	Liner, O.D. Sealing	1	298	Spacer Manifold	1
**45	Breather	1	305	Soc. Hd. Cap Screw	2
**46	Sight Gauge	1	370	Soc. Hd. Cap Screw	4
*51	Gasket, Piston Housing	1	810	Locating Tube	1
*53	Gasket, Input Housing	1	900	Control Valve Assembly	1
*54	Gasket, Manifold	1	901	Receptacle, 4 Pin	1

* - Indicates parts in Minor Overhaul Kit

** - Indicates parts in Major Overhaul Kit. (Plus all parts in Minor Overhaul Kit)

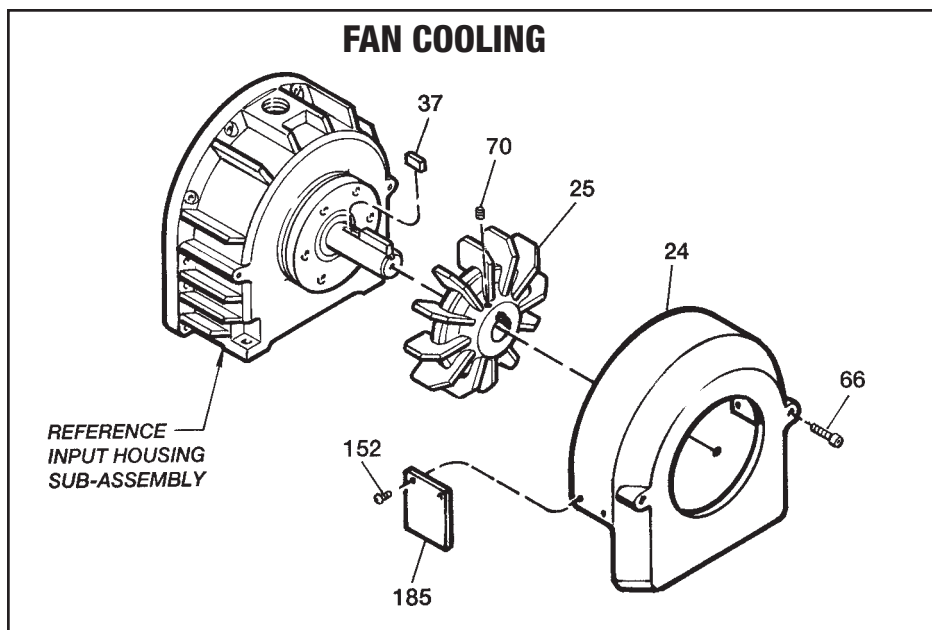
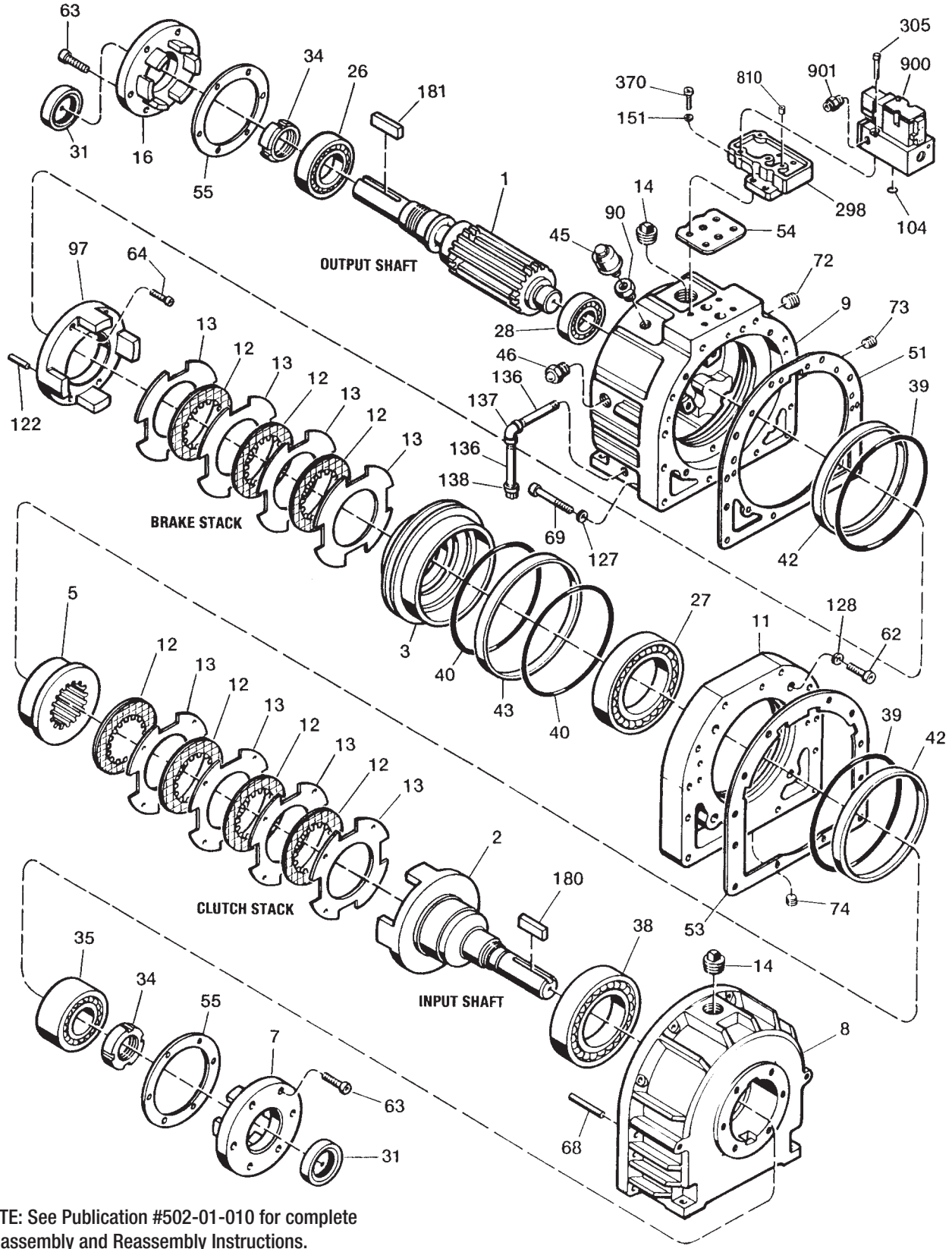

Figure 7.6 - Fan Cooling

2.5 Posidyne® CLUTCH and BRAKE UNIT



NOTE: See Publication #502-01-010 for complete Disassembly and Reassembly Instructions.

Figure 7.7 - 2.5 Posidyne Clutch/Brake Unit

CLPC Series II Control and Optional Junction Box (Figures 7.8 and 7.9)

REF No.	PART NAME	QTY.	REF No.	PART NAME	QTY.
*1	CPU Circuit Board, Zero Power RAM	1	29	Terminal Strip, 16 Circuit	1
3	Power Supply Board, Zero Power RAM	1	30	Terminal Strip, 12 Circuit	2
4	Fuse, 1.5 Amp, 250 Volt	2	31	Terminal Strip, 10 Circuit	1
5	Microfuse, 3 Amp. ,250 Volt	AR	33	Interface Cable CPU/PS Boards	1
8	Input Relay, Solid State		34	Wiring Harness	1
	AC, Yellow, IAC5	AR	35	Removable Jumper, Shunt Bar	17
	DC, White, IDC5	AR	36	Overlay, Door Face Plate	1
9	Output Relay, Solid State		40	Junction Box	1
	AC, Black, OAC5	AR	41	Terminal Block	
	DC, Red, ODC5	AR		Open Collector Quadrature Encoder	14
22	H-O-A Switch	1		Differential Line Encoder	15
25	Jog Switch	1	42	Cable, 3 Pin Connector	1
27	Transformer Assembly	1	43	Cable, 4 Pin Connector	1
28	Terminal Strip, 3 Circuit	1	44	Cable, 5 Pin Connector	1

*-Specify Software Version when ordering a CPU Board.
AR-As Required.

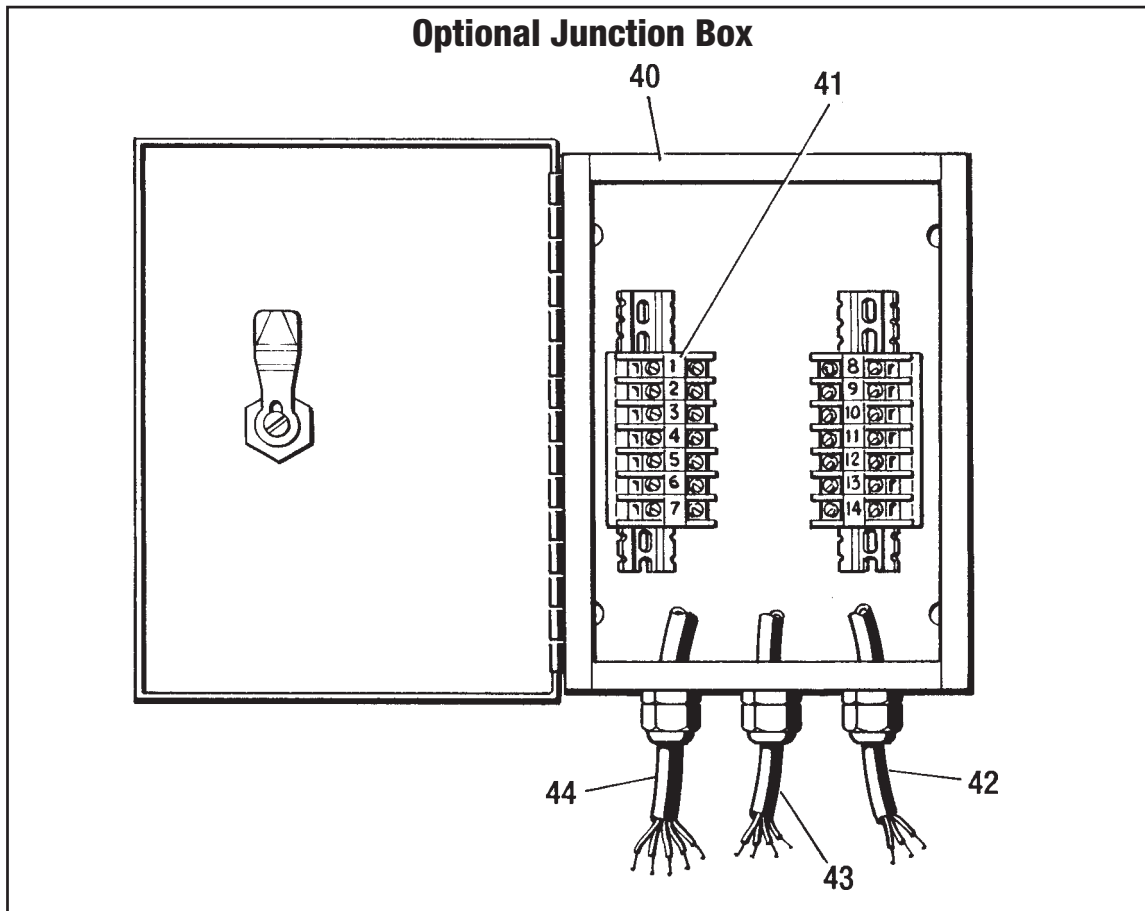
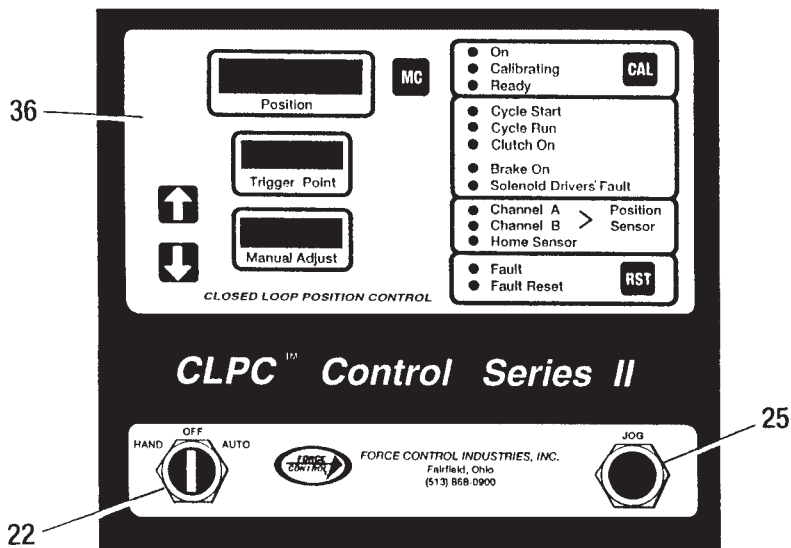
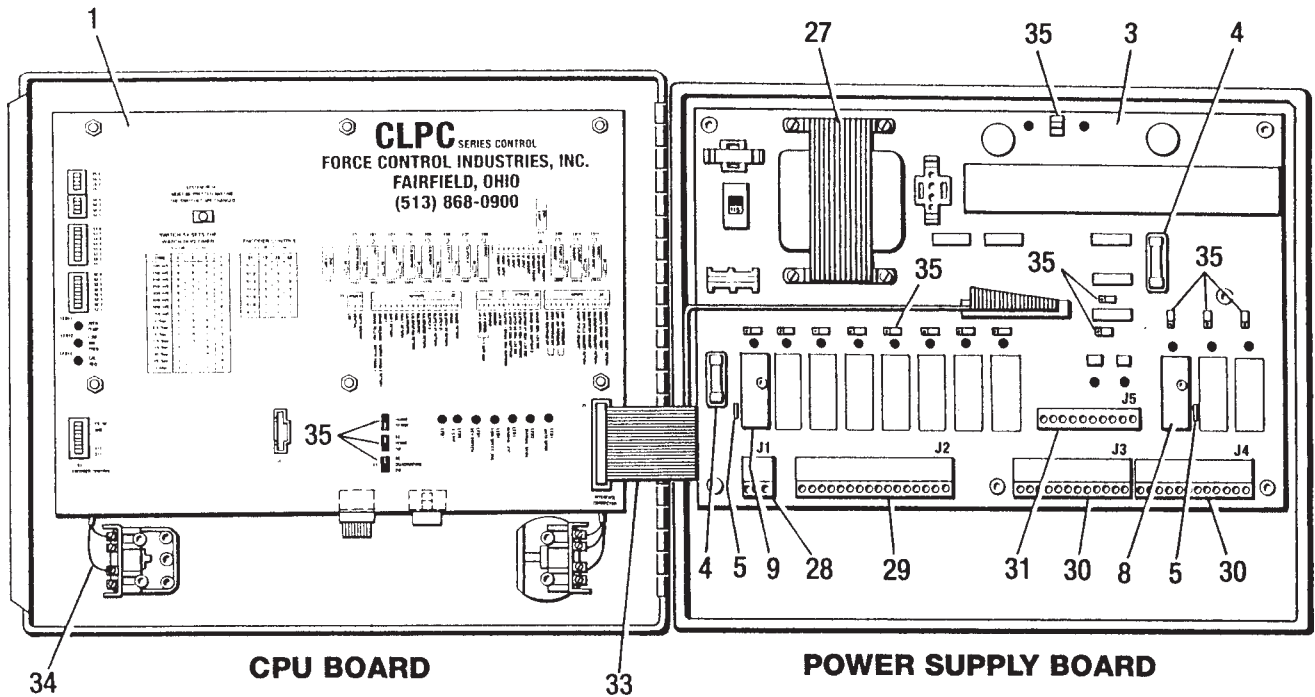

Figure 7.8 - Optional Junction Box

CLPC CONTROL Series II



FRONT PANEL



See Page 36 for Correct Installation

Figure 7.9 - CLPC Control Series II

CLPC CONTROL Series II CPU BOARD

DIP SWITCHES (See Section 3 - Start-Up and Operation)

- S1 - ENCODER CONTROL
- S2 - MISC. FUNCTIONS
- S3 - MISC. FUNCTIONS
- S4 - WATCH DOG TIMER
- S5 - CONTROL MODE

INTERNAL SYSTEM RESET BUTTON

SYSTEM RESET
MUST BE PRESSED ANYTIME
THE DIP SWITCHES ARE CHANGED

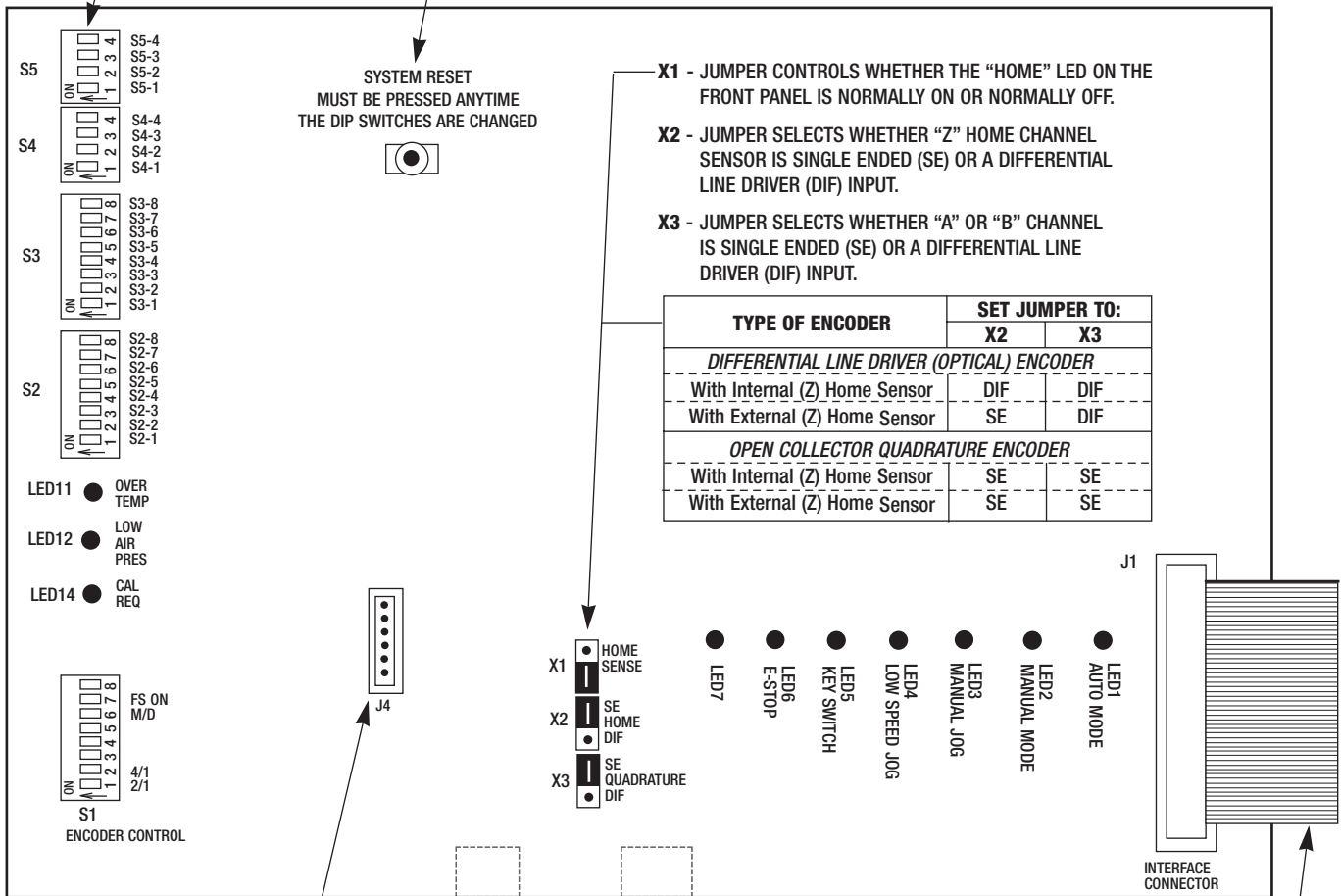

- X1** - JUMPER CONTROLS WHETHER THE "HOME" LED ON THE FRONT PANEL IS NORMALLY ON OR NORMALLY OFF.
- X2** - JUMPER SELECTS WHETHER "Z" HOME CHANNEL SENSOR IS SINGLE ENDED (SE) OR A DIFFERENTIAL LINE DRIVER (DIF) INPUT.
- X3** - JUMPER SELECTS WHETHER "A" OR "B" CHANNEL IS SINGLE ENDED (SE) OR A DIFFERENTIAL LINE DRIVER (DIF) INPUT.

TYPE OF ENCODER	SET JUMPER TO:	
	X2	X3
<i>DIFFERENTIAL LINE DRIVER (OPTICAL) ENCODER</i>		
With Internal (Z) Home Sensor	DIF	DIF
With External (Z) Home Sensor	SE	DIF
<i>OPEN COLLECTOR QUADRATURE ENCODER</i>		
With Internal (Z) Home Sensor	SE	SE
With External (Z) Home Sensor	SE	SE

COMMUNICATIONS BOARD
ELECTRICAL CONNECTOR.

OVERLAY ELECTRICAL CONNECTOR.

H-O-A SWITCH AND JOG SWITCH
ELECTRICAL CONNECTOR.

USE BLUE INTERCONNECTING CABLE
WITH POWER SUPPLY Revision "B"

CLPC II Revision History

REVISION NUMBER	DATE	FEATURE, IMPROVEMENT	SYSTEM HARDWARE	NOTES
REVISION NAMING CONVENTION STARTED WITH 1 DOT NOTATION. ALL SYSTEM CALCULATIONS ARE PERFORMED USING 16 BIT ARITHMETIC.				
1.08	10/10/93	-Changed Stop Check from 50mS to 100mS.	EE Prom BH CPU	Currently installed on Auto Catcher Applications.
1.09	12/1/93	-Changed Stop Check from 100mS to 25mS.	EE Prom BH CPU	Improved timing to increase cycle rates on Auto Catcher Applications.
3.05	9/19/94	-Significant Weaver support updated.	EE Prom BH CPU	Migration path of CLPC to include Weaver Application.
3.06	10/10/94	-Changed Stop Check from 100mS to 25mS.	EE Prom BH CPU	Special Application.
4.04	11/18/94	-First version supporting Zero Power Ram. -Calibration input must be activated for each Index until the calibration is complete. -Limited manual adjust offset to $\pm 90^\circ$.	Zero Power Ram BH CPU	First major board revision. Introduction of Zero Power Ram Chip.
CHANGED REVISION NAMING CONVENTION TO 2 DOT NOTATION. ALL SYSTEM CALCULATIONS ARE PERFORMED USING 32 BIT ARITHMETIC.				
2.0.4	12/8/95	-Added support for IP/PLS hardware. -Added Stall Detection capabilities.	Zero Power Ram BH CPU	Added In Position and Programmable Limit Switch function through an Expansion Board.
2.0.7	6/19/96	-Corrected IP/PLS start-up problems.	Zero Power Ram BH CPU	Last version supported by BH CPU.
2.1.0	2/16/98	-Added Multiple System Parameter Support.	Zero Power Ram KB CPU	First version supported by the KB CPU.

Revision Naming Convention Definitions:

* 1 Dot Notation - M.N Where: M = Major Revision Number; N = Minor Revision Number.

** 2 Dot Notation - S.V.E Where: S = CLPC Series Number; V = Version Number; E = Edit Level Number

System Hardware:

EE Prom Type of Computer Memory

Zero Power Ram Type of Computer Memory

BH CPU Usable Types, 8096BH or 8097BH

KB CPU Usable Types, 80C196KB or 90C196KB-16

FORCE CONTROL INDUSTRIES, INC.

*Providing todays industries
with Oil Shear Clutch and
Brake Drives that deliver...*

- Flexibility •Efficiency
- Endurance •Performance
- and •Dependability

"BUILT TO LAST - GUARANTEED TO PERFORM"



FORCE CONTROL INDUSTRIES, INC.

MAIN OFFICE

P. O. Box 18366
Fairfield, Ohio 45018

3660 Dixie Highway
Fairfeild, Ohio 45014

Tel: (513) 868-0900
Fax: (513) 868-2105

DETROIT OFFICE

2716 Stair Street
Detroit, Michigan 48209

Tel: (313) 842-5393
Fax: (313) 842-5399

E-Mail: info@forcecontrol.com Web Site: www.forcecontrol.com



MEX (55) 53 63 23 31 MTY (81) 83 54 10 18
QRO (442) 1 95 72 60 ventas@industrialmagza.com