



502-280-223-02

SERVICE MANUAL

AND

REPAIR PARTS

FOR

Model: MB-280-223

and MB-280-238

***BESCOSTOP™* OIL**

SHEAR MOTOR BRAKE

BESSER P/N 113759

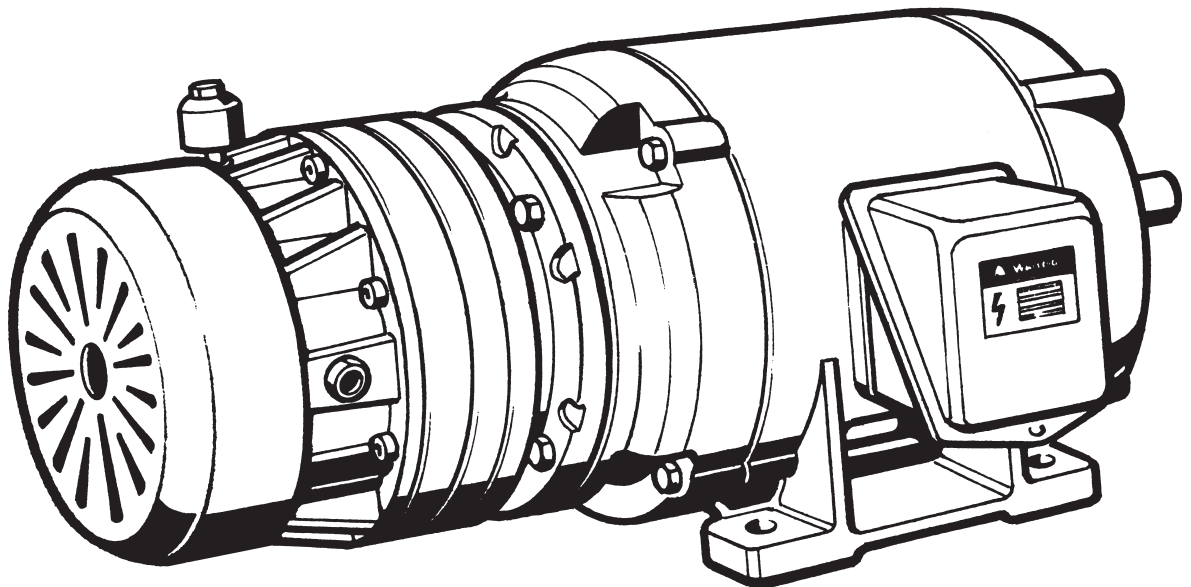

MANUFACTURED FOR :

BESSER COMPANY

MANUFACTURED BY:



FORCE CONTROL INDUSTRIES, Inc.

WARNING - Read this manual before any installation, maintenance and operation.

MANUFACTURERS OF MECHANICAL AND ELECTRICAL POWER TRANSMISSION EQUIPMENT



MEX (55) 53 63 23 31 MTY (81) 83 54 10 18
QRO (442) 1 95 72 60 ventas@industrialmagza.com

Table of Contents

Section 1 - DESCRIPTION and OPERATION

1-1	MANUAL DESCRIPTION	1
1-2	THE OIL SHEAR PRINCIPLE	1
1-3	DESCRIPTION	1
1-4	FEATURES	1
1-5	OPERATION	2

Section 2 - SPECIFICATIONS

2-1	DIMENSIONAL SPECIFICATIONS	3
2-2	OPERATIONAL SPECIFICATIONS	3

Section 3 - INSTALLATION

3-1	INSTALLATION PROCEDURE	4
-----	------------------------------	---

Section 4 - LUBRICATION

4-1	CHECKING THE OIL LEVEL	6
4-2	CHANGING THE OIL	6
4-3	TYPE OF OIL	6

Section 5 - OPERATIONAL CHECKS

5-1	OPERATIONAL CHECKS	7
-----	--------------------------	---

Section 6 - TROUBLESHOOTING

	TROUBLESHOOTING CHART	8
--	-----------------------------	---

Section 7 - DISASSEMBLY

7-1	DISCONNECTING THE MOTOR BRAKE FROM THE DRIVE MOTOR	9
7-2	"IN PLACE" REMOVAL OF THE FAN (#25)	9
7-3	"IN PLACE" REMOVAL OF END HOUSING FOR ACCESS TO THE BRAKE STACK	9
7-4	HUB (#2) REMOVAL AND DISASSEMBLY	10
7-5	PISTON HOUSING DISASSEMBLY	11
7-6	REMOVING OIL SEALS	11

Section 8 - CLEANING AND INSPECTION

8-1	CLEANING AND INSPECTION	11
8-2	REPAIR OR REPLACEMENT	11

Section 9 - REASSEMBLY

9-1	GENERAL REASSEMBLY INSTRUCTIONS	12
9-2	INSTALLING OIL SEALS	12
9-3	HUB REASSEMBLY	12
9-4	PISTON HOUSING ASSEMBLY	13
9-5	INSTALLING HUB (#2)	13
9-6	INSTALLING SEPARATOR SPRINGS	13
9-7	INSTALLING BRAKE STACK	14
9-8	INSTALLING END HOUSING (#9) TO BRAKE ASSEMBLY	14
9-9	INSTALLING COOLING FAN (#25)	15
9-10	INSTALLING BRAKE ASSEMBLY TO DRIVE MOTOR	15
9-11	FINAL REASSEMBLY PROCEDURE	15

Section 10 ORDERING REPAIR PARTS

10-1	GENERAL INFORMATION	17
10-2	ORDERING REPAIR PARTS	17
10-3	NAME PLATE INFORMATION	17
10-4	FACTORY REBUILD SERVICE	17
10-5	REPAIR PARTS LIST	18
	Figure 10.1 - CONTROL VALVE MOUNTING KIT	18
	Figure 10.2 - MOTOR BRAKE ASSEMBLY	19

Section 1

DESCRIPTION and OPERATION

1-1 MANUAL DESCRIPTION

This manual covers the BESCOSTOP Oil Shear Motor Brakes, Models MB-280-223 (Old Style) and MB-280-238 (New Style). These (2) brakes are identical except for the Cooling Fan as shown in Figure 10.2. The Installation, Disassembly and Reassembly Procedures described in this manual reflects the new style fan. The old fan that was used in the MB-280-223 Motor Brake is no longer available. It has been changed to a new style fan that requires a Clamping Collar to hold it in place on the Hub.

NOTES - If you order a Replacement Fan, you will receive the new style along with the Clamping Collar and attaching screws.

The Besser Part Number 113759 is the same for both models.

1-2 THE OIL SHEAR PRINCIPLE

Conventional clutches and brakes depend on the friction between solid surfaces operating in air to transmit torque. Friction does the job, but produces a great amount of HEAT and WEAR, causing an increase in replacement parts, breakdown and maintenance time.

OIL SHEAR TECHNOLOGY was pioneered by Force Control in 1959 and resulted in one of the most energy efficient Brake/Clutch/Variable Speed Drive Systems available today.

In 1970 Force Control introduced an Integral Oil Pump, which requires no additional parts. This oil pump forces a positive oil feed from the center of the brake disc stack to "Float" the friction surfaces in a continuously circulating bath of oil.

The oil molecules tend to cling to each other and also to the friction surfaces. As moving and stationary surfaces are brought together, a thin but positive film of oil is maintained between them and is controlled by the clamping pressure and grooves designed into the braking surfaces.

TORQUE is transmitted from one surface to the other through the viscous shear of the oil film. The braking surfaces are protected by this oil film, which reduces wear and effectively transmits heat away from the braking surfaces.

...thus brake wear is greatly reduced along with all routine maintenance common to conventional dry motor brakes.

AN OIL CHANGE EVERY (3) THREE MONTHS IS ALL THAT IS REQUIRED FOR NORMAL MAINTENANCE.

1-3 DESCRIPTION

BESCOSTOP Motor Brakes are multiple surface, spring activated, pneumatic release braking devices that effectively dissipate the heat generated from electric motors requiring frequent starting and stopping,

This Manual covers the MB-280-223 and MB-280-238. For information on other sizes and models not covered in this manual, contact Besser Company.

1-4 FEATURES (See Figure 1.1)

1. **NEMA-C STANDARD FLANGE MOUNTING** to any suitable double shaft drive motor.
2. **"COLLET" LOCKING ELEMENT** for a positive self locking, keyless hub mounting with high torque transmitting capabilities.
3. **"COLLET" ADVANTAGES:**
 - a. **CONVENIENT EASY MOUNTING** - No press fits or costly machining necessary. Allows use of commercial tolerance motor shafts.
 - b. **EASY RELEASING AT DISASSEMBLY.**
 - c. **TOTALLY SELF CENTERING.**
 - d. **FULL SHAFT STRENGTH** - Since no metal is removed, stress concentrations are avoided permitting shafts to retain their full strength.
4. **INTERNAL CENTRIFUGAL TYPE OIL PUMP** - Maintains positive oil film between braking surfaces without external pumping devices.
5. **FAN COOLING** - For maximum and efficient heat dissipation.
6. **MULTIPLE BRAKING DISC STACK** - At the heart of your BESCOSTOP Motor Brake is a multiple braking disc stack consisting of drive plates, keyed to the piston housing and friction discs, splined to the drive hub.

AS A RESULT, THE TORQUE is distributed along the hub rather than on a single braking surface reducing the heat and wear on each brake disc.

1-5 OPERATION

The BESCOSTOP Motor Brake Cross Section (Figure 1.1) shows the brake in the normally spring loaded braking position. Figure 1.1 also shows the Model MB-280-238 with the new style fan.

Compressed air, controlled by external valving, enters the piston housing and moves the piston to disengage the multiple braking disc stack, allowing the drive motor to rotate freely.

When the air pressure is released the piston (spring loaded) returns to the normal braking position.

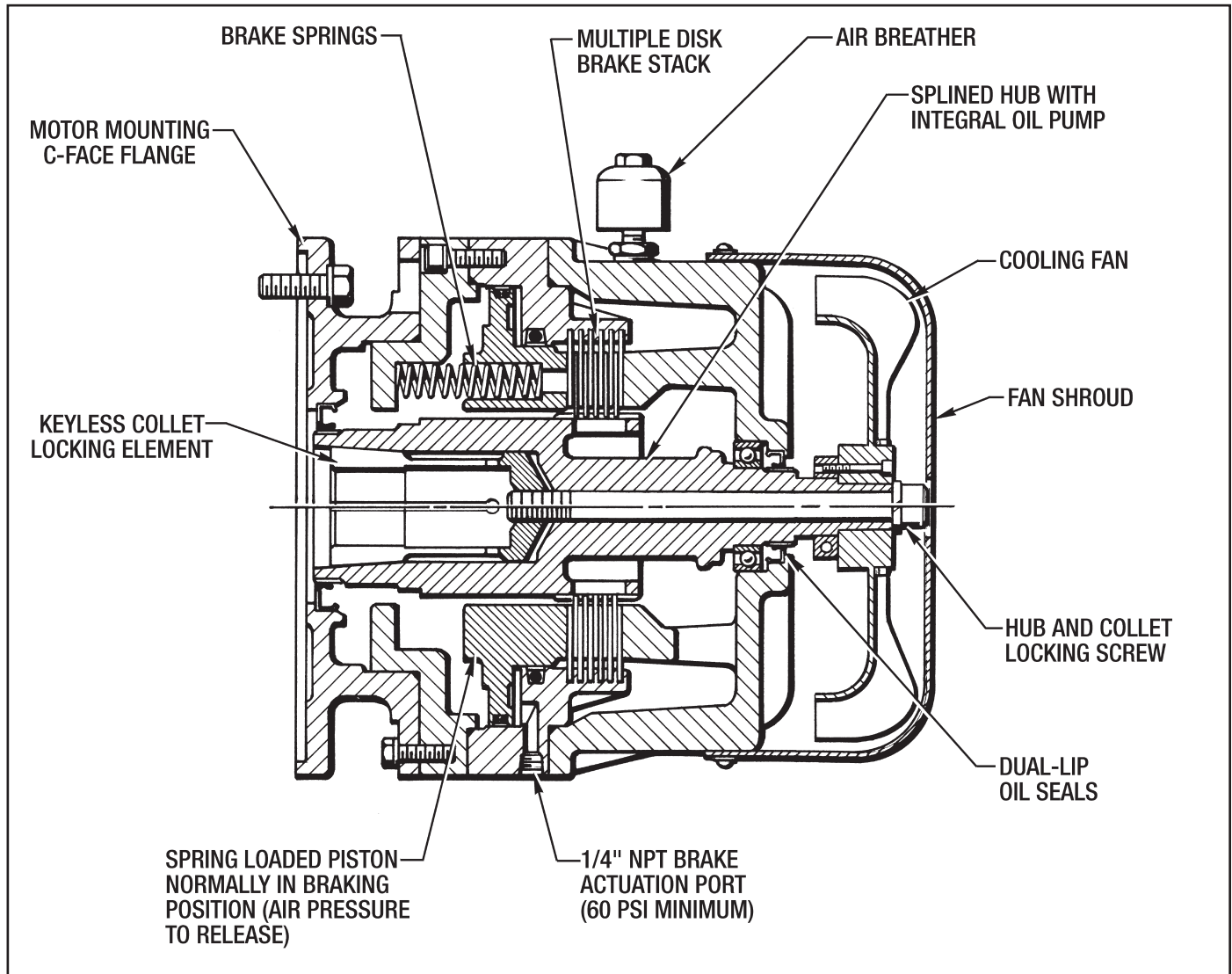

Figure 1.1 - Motor Brake Cross Section

Section 2 SPECIFICATIONS

2-1 DIMENSIONAL SPECIFICATIONS

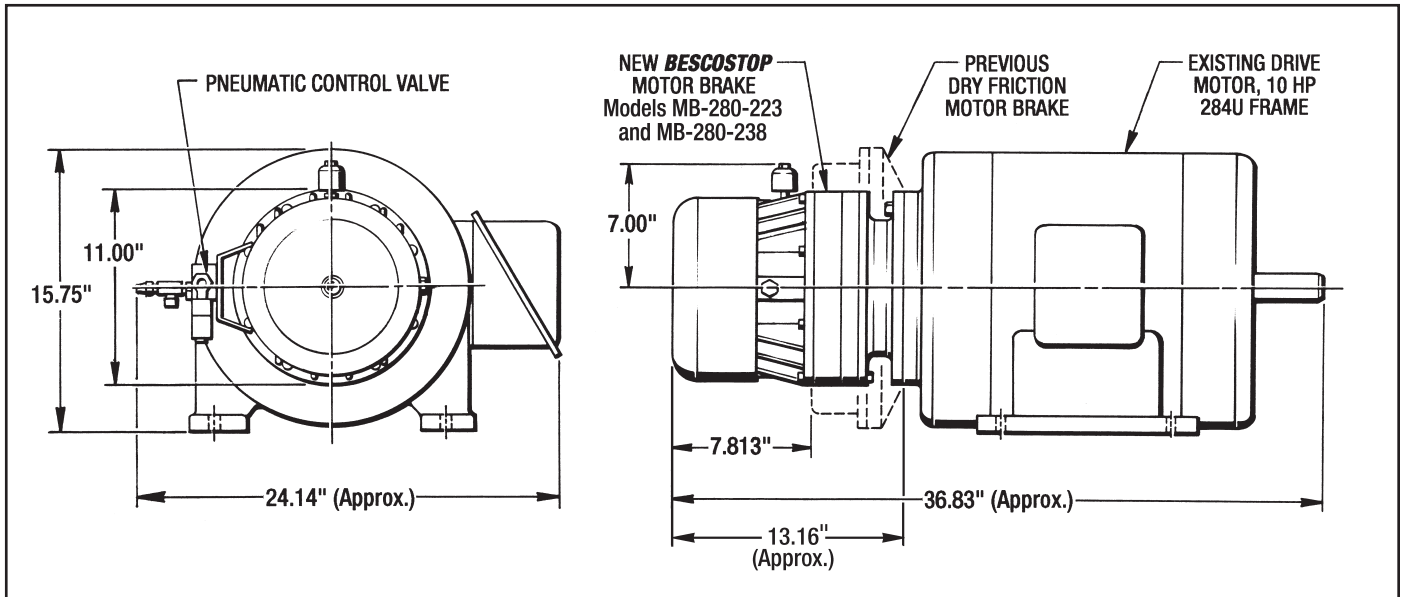

Figure 2.1 - Dimensional Drawing

2-2 OPERATIONAL SPECIFICATIONS

MODEL NUMBER	NOMINAL STATIC TORQUE Lb. Ft.	NOMINAL DYNAMIC TORQUE Lb. Ft.	MINIMUM PRESSURE TO RELEASE P.S.I.	MAXIMUM PRESSURE TO RELEASE P.S.I.	NUMBER OF SPRINGS	THERMAL RATING HP Sec/Min	CYCLE WK ² Lb. Ft. ²	PISTON VOLUME Cu. In.	MAX. SPEED R.P.M.	APPROX. OIL CAPACITY
MB-280-223 MB-280-238	300	260	60	80	6	120	.215	5	1800	2 Qts.

Table 2.1

TORQUE CAPACITY

The Assembly Configuration for the Drive Plates #12 and #18 and the Friction Discs #13 are shown in Figure 2.2.

See 9-6 INSTALLING SEPARATOR SPRINGS and 9-7 INSTALLING BRAKE STACK located in Section 9 on Pages 13 and 14 for Assembly Procedure.

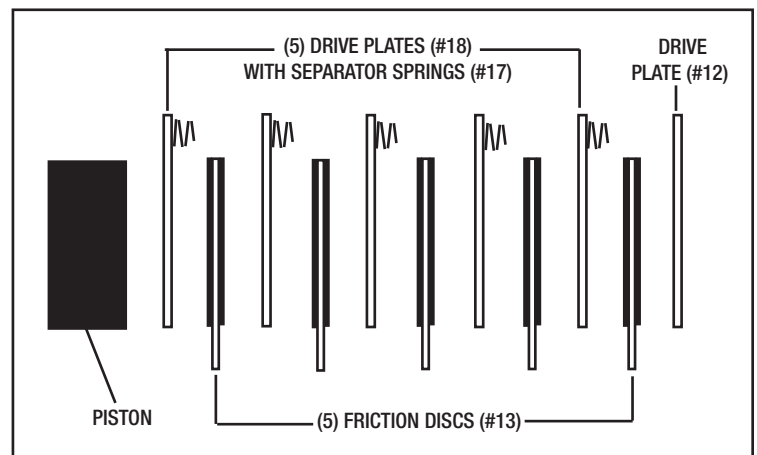

Figure 2.2 - Brake Stack Assembly Configuration

Section 3 INSTALLATION

IMPORTANT SAFETY PRECAUTIONS

The brake units described in this manual must not be installed in any manner except as specified herein, and must not be operated at speeds, torque loads or temperatures other than those specified in this manual. Failure to limit operation of the brakes to the conditions specified could damage the units and may cause malfunction or damage to interconnecting equipment.

WARNING

The following precautions must be taken if the installation of the BESCOSTOP Motor Brake is to be a retrofit for an existing application. Before attempting installation, open the motor disconnect, shut off the control electrical supply and shut off the air supply then lock them out to avoid the possibility of personal injury.

NOTE

The BESCOSTOP Motor Brake has been partially assembled at the factory for ease of shipment. Partial disassembly will be necessary to assemble the brake to the motor.

This Installation Procedure only covers the initial retrofit installation of the motor brake to the drive motor. See Section 7 for complete Disassembly and Section 9 for Reassembly Procedure.

See Figures 10.1 and 10.2 for a visual reference to the parts.

A **Special Installation Tool** is used to install the brake unit to the drive motor. This tool can be ordered from the Besser Company with the **Part Number 114807**.

Dimensions and material specifications are given in Figure 3.1 if you prefer to make your own.

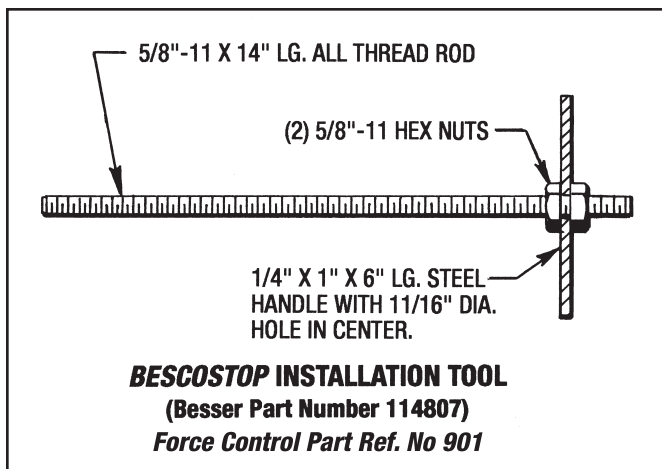

Figure 3.1 - Special Installation Tool

3-1 INSTALLATION PROCEDURE

(See Figure 10.2)

1. First check the motor shaft for any nicks or burrs. Clean up and deburr as necessary.

CAUTION

Do not use any molybdenum disulfide "MOLYKOTE" or any other similar lubricant on the motor shaft. The collet hub locking element is keyless and depends on friction to transmit torque from the brake to the shaft.

2. The Collet (#110) is shipped inside the Hub (#2). Manually pull it out of the bore.

NOTE: There is a cardboard retainer holding the collet in the hub. This can be removed by hand.

3. Remove the Fan Shroud (#24) by taking out the (4) Screws (#166) and (4) Lockwashers (#167).

NOTE: The Fan (#25) does not have to be removed.

4. Align the Hub (#2) approx. 3/16" from the machined surface of the motor mounting flange as shown in Figure 3.2.

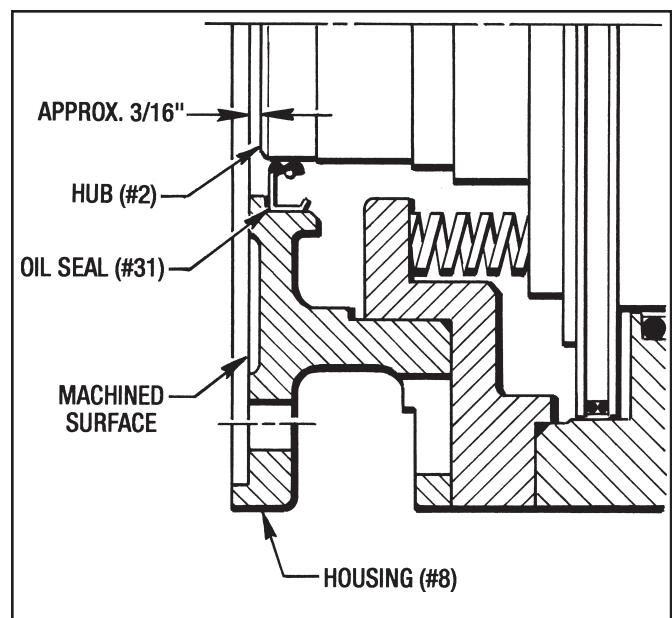

Figure 3.2 - Hub Alignment

- Thread the **Special Installation Tool #114807** into the Collet (#110) and place the collet all the way on the motor shaft. (See Figure 3.3)

IMPORTANT

Only thread the tool to thread hole depth into the collet as shown in Figure 3.3.

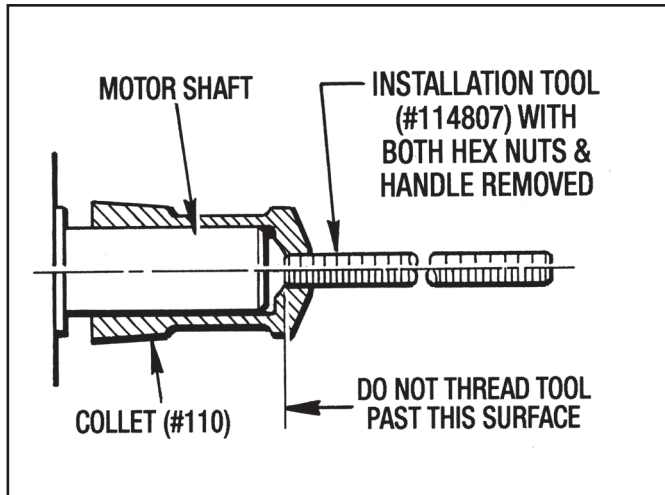

Figure 3.3 - Installing Collet on Motor Shaft

- Remove the (2) Hex Nuts and Handle from the **Installation Tool (#114807)**.
- Attach an overhead hoist and sling to the Brake Assembly and slide it onto the motor shaft. (See Figure 3.4)

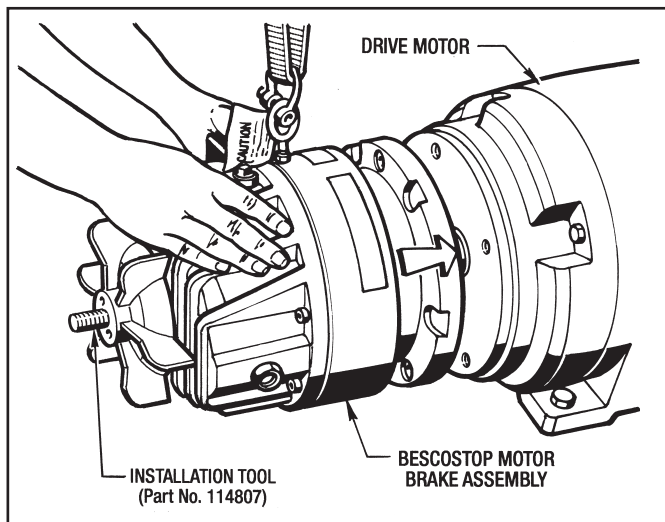

Figure 3.4 - Installing Brake onto Drive Motor

- Attach the Brake Assembly to the Drive Motor with (4) Screws (#150) and (4) Lockwashers (#128). **Torque to 60 Ft. Lbs.**

NOTE: Insert the screws head first into the machined pockets to allow for proper clearance to the mounting holes as shown in Figure 3.5. **Do not use shorter screws.**

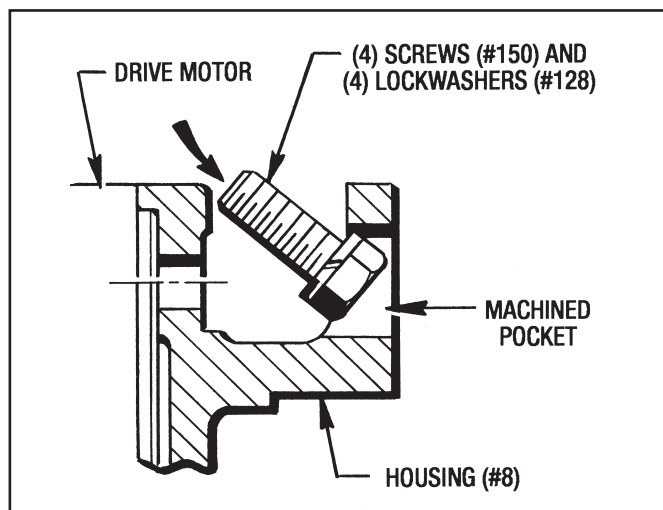

Figure 3.5 - Installing Motor Mounting Screws

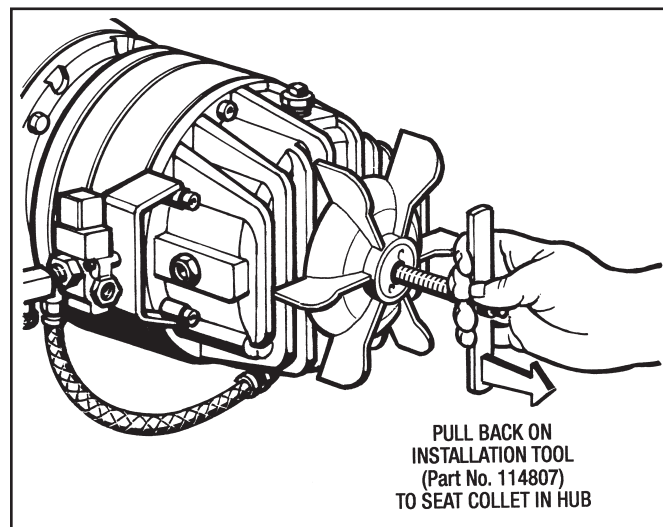

Figure 3.6 - Seating Collet into Hub

- Reattach the handle to the Installation Tool and manually pull back to seat the Collet (#110) into the Hub (#2) bore as shown in Figure 3.6.

IMPORTANT

It does not require excessive force to seat this collet properly.

- Remove the Installation Tool from the Brake.
- Install the Hub Locking Screw (#94) and Lockwasher (#168). **Torque to 120 Ft. Lbs.**

IMPORTANT

It is very important that this Hub Locking Screw (#94) be torqued to 120 Ft. Lbs. otherwise the Brake may not function properly.

- Reinstall the Fan Shroud (#24) with (4) Screws (#166) and (4) Lockwashers (#167).
- Remove the red plastic pipe plug from the top of the brake and fill the unit with fresh oil as directed in **Section 4 - LUBRICATION.**

BESSER COMPANY



MEX (55) 53 63 23 31 MTY (81) 83 54 10 18
QRO (442) 1 95 72 60 ventas@industrialmagza.com

14. Make an Operational Check of the Brake Unit as specified in **Section 5**.
15. Install Reducer Bushing (#76) and Air Breather (#45) into the top of the brake. (See Figure 3.7 below.)

IMPORTANT

It is very important that this Breather (#45) be installed before the BESCOSTOP Brake is put into service.

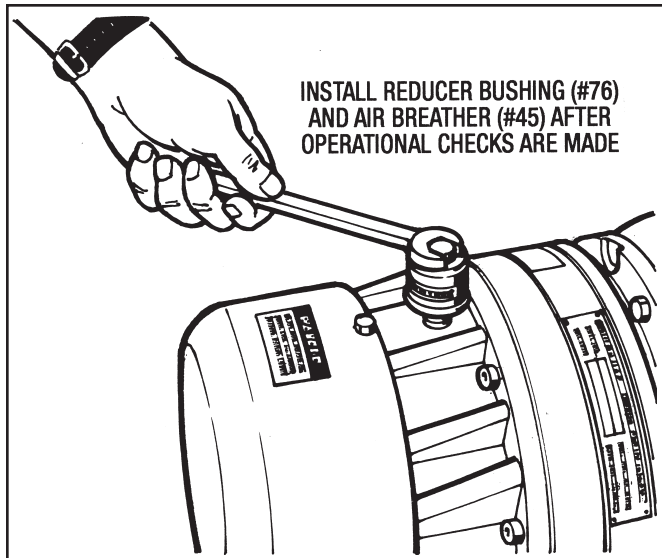

Figure 3.7 - Installing Air Breather (#45)

16. Connect electrical and pneumatic lines to the control valve. (See Figure 3.8 for Control Valve Schematic.)

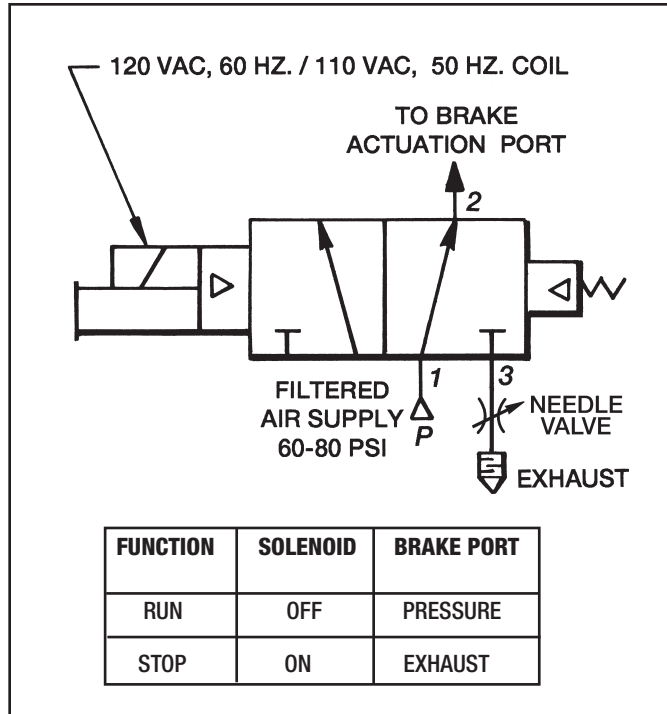

Figure 3.8 - Control Valve Schematic

Installation is now complete and your BESCOSTOP Motor Brake is ready for service.

Section 4 LUBRICATION

4-1 CHECKING THE OIL LEVEL

Check the oil level when the drive is installed and weekly thereafter (until experience dictates otherwise). Always check the oil level with the unit stationary (not running).

NOTES :

There is a L.H. Drive and a R.H. Drive. Both units are setting at approx. 11° and have (2) Sight Gauges (#46) installed in the brake housing. **The oil level is to be at the center of the highest sight gauge as shown in Figure 4.1.**

4-2 CHANGING THE OIL

Every three (3) months remove Drain Plug (#74) at the bottom of the End Housing (#9) and the Pipe Cap (#67) at the bottom of Housing (#8). Drain all oil before refilling. More frequent oil change may be required on high kinetic energy applications or in extremely dirty environments.

Check both Oil Sight Gauges (#46) for dirt. Remove and clean them if necessary. Replace the drain plugs

and sight gauges. Remove the Pipe Plug (#78) from the Elbow (#125) and refill unit with clean oil up to the center of the appropriate sight gauge as shown in Figure 4.1. Approximate capacity is **just over 2 Quarts**.

CAUTION

Do not over fill with oil. Excess oil will cause the unit to overheat

4-3 TYPE OF OIL

Only use Mobil Automatic Transmission Fluid ATF-210 (Type F) or Mobil Multi-Purpose Automatic Transmission Fluid.

CAUTION

Use of the wrong brand or type of Automatic Transmission Fluid will cause erratic operation, premature wear, damage to the unit and void the warranty.

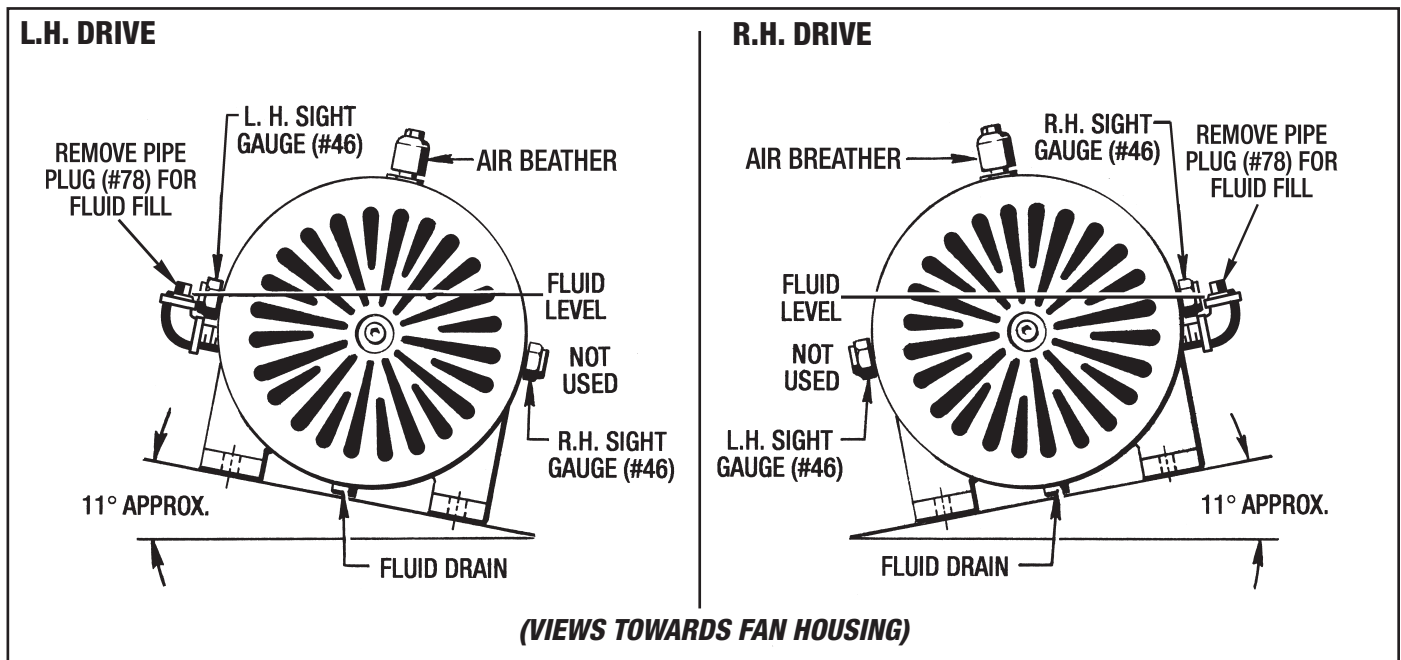

Figure 4.1 - Checking Oil Level

Section 5 OPERATIONAL CHECKS

WARNING

Make Operational Checks only when the drive motor and motor brake are not in operation. Open motor disconnect and lock it out to avoid personal injury.

5-1 OPERATIONAL CHECKS

1. Make provisions for manual operation, if automatic controls are used, .
2. Remove Air Breather (#45) and Reducer Bushing (#76) from End Housing (#9). **Do not remove while motor is operating.**
3. Apply 60 to 80 P.S.I. air pressure to the brake and observe the action of the piston through the air breather port. If the piston action is irregular, or if it tends to stick or bind, internal damage may be indicated.
4. Exhaust the air pressure and observe that the piston returns quickly and smoothly back to the normal braking position.
5. Reinstall the Reducer Bushing (#76) and the Breather (#45) back into the End Housing (#9).

air breather port. If the piston action is irregular, or if it tends to stick or bind, internal damage may be indicated.

Listen and look for air bubbles in the oil which would indicate piston leakage

If the piston moves slowly and leaks are evident, the piston seals may be damaged.

Section 6 TROUBLESHOOTING

TROUBLE	POSSIBLE CAUSE	REMEDY
A. Brake fails to engage properly.	Piston sticking or binding. Worn Friction Discs. Weak or broken spring. Air pressure not exhausting or slow in exhausting.	Disassemble to the extent necessary and inspect for damaged parts. Replace Brake Stack. Replace as needed. Check air regulator valve and replace if necessary.
B. Brake engages too quickly.	Low oil level.	Check oil level and correct.
C. Noise and vibration.	Improper or loose mounting on motor.	Check mounting and correct. If partial disassembly is required, refer to Installation Section 3.
D. Brake fails to disengage properly.	Low air pressure. Piston sticking or binding. Air regulator valve not functioning properly.	Increase pressure (See Table 2.1). Disassemble to the extent necessary and inspect for damaged parts. Check valve operation and replace if necessary.
E. Unit overheats. (Temperature over 225 °F).	Brake not engaging or disengaging properly causing excessive slippage. Improper oil level. Fan loose on shaft.	Refer to troubles A and D. Check level and add or drain as necessary. Tighten fan holding screw.
F. Oil leakage.	Oil Seal lip damaged or Wear Sleeve damaged. O-ring seals.	Check for oil leaking around the shaft. Replace if necessary. Tighten all external bolts.
G. Oil leakage at breather.	Damaged seal around piston. Oil level too high.	Disassemble and replace. Drain excess oil.
H. Brake does not repeat.	Air pressure changed. * Oil temperature changed.	Check and adjust air pressure. Check temperature.

* **NOTE** - For installations requiring precise starting and stopping, operating temperatures are important. Operating temperatures between 116° F and 165 ° F. are recommended.

Section 7 DISASSEMBLY

WARNING

Before attempting disassembly of the BESCOSTOP Motor Brake, open the motor disconnect, shut off the control electrical supply and shut off the air supply. Lock them out to avoid the possibility of any personal injury.

Unless the brake is to be completely overhauled, it should be disassembled only to the extent necessary to gain access to the worn or damaged parts.

See Figures 10.1 and 10.2 for a visual reference to all the parts.

7-1 DISCONNECTING THE MOTOR BRAKE FROM THE DRIVE MOTOR

1. Remove Drain Plug (#74) and Pipe Cap (#67) and drain all the fluid into a suitable container. Save or discard as the condition warrants. Also remove the Air Breather (#45) so it doesn't get damaged.
2. Disconnect the pneumatic air lines and electrical connections to the Control Valve (#270).
3. Remove the Fan Shroud (#24) by taking out (4) Screws (#166) and (4) Lockwashers (#167).
4. Remove the Hub Locking Screw (#94) and Lockwasher (#168) from the end of the Hub (#2) with an impact wrench.
5. Install an eyebolt and soft sling to the top of the brake.

6. Remove the (4) Mounting Bolts (#150) and (4) Lockwashers (#128) from the Housing (#8).

NOTE - A Special Disassembly Tool and a Jack Bolt has to be used to disengage the Collet (#110) from the Hub (#2). These can be ordered from the Besser Company by using the **Part Number 114806**.

Dimensions and material specifications are given in Figure 7.1 if you prefer to make your own.

7. Insert the **Disassembly Tool (#114806)** into the end of the Hub (#2) and thread it into the Collet (#110) using a flat head screw driver. Leave about 3/4" to 1" exposed thread in the Hub (#2) as shown in Figure 7.2.

Install the Jack Bolt into the end of the Hub (#2) and tighten to release the Collet (#110) from the hub bore. (See Figure 7.2)

8. Insert a large flat head screw driver between the motor face and Housing (#8). Pry the Brake Assembly away from the drive motor. Pull the Brake assembly straight back until it clears the Disassembly Tool.
9. Remove the Collet (#110) from the motor shaft and unscrew the tool from the collet threads.

7-2 "IN PLACE" REMOVAL OF THE FAN (#25)

(See Figures 10.1 and 10.2)

1. Remove the Fan Shroud (#24) by taking out the (4) Screws (#166) and (4) Lockwashers (#167).
2. Remove the (2) Screws (#149) and pull the Fan (#25) off the Hub (#2).

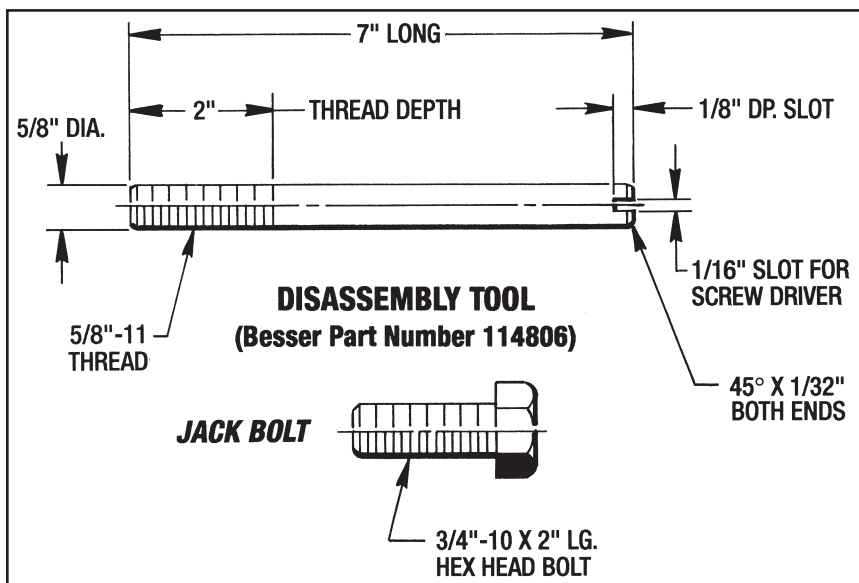

It is not necessary to remove the Clamping Collar (#331) if you are just replacing the Fan (#25), but if you also plan on removing the End Housing (#9) then you must remove the Clamping Collar (#331) from the Hub (#2).

3. Loosen the 1/4"-20 Screw in the Clamping Collar (#331) and pull the Collar off the Hub (#2).

7-3 "IN PLACE" REMOVAL OF END HOUSING FOR ACCESS TO THE BRAKE STACK

(See Figures 10.1 and 10.2)

1. Remove Drain Plug (#74) and Pipe Cap (#67) and drain all the fluid into a suitable container. Save or discard as the condition warrants.

Figure 7.1 - Disassembly Tools

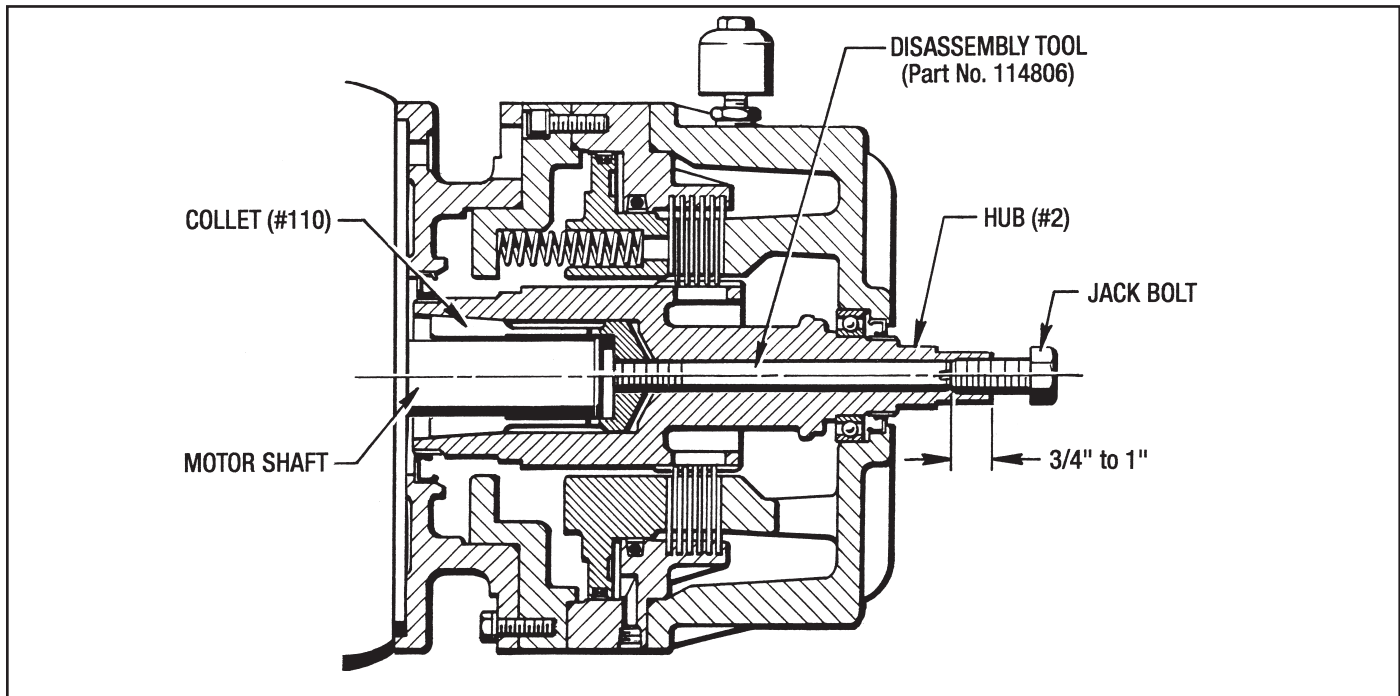

Figure 7.2 - Removing Brake from the Drive Motor

2. Remove the Fan Shroud (#24), Fan (#25) and Clamping Collar (#331) from the brake unit with the same procedure as described in the previous Section 7-2
3. Remove (6) Screws (#72) and (6) Lockwashers (#127) from the End Housing (#9). Also remove the (2) Screws (#273) and (2) Lockwashers (#275) holding the Control Valve Mounting Bracket (#271) to the End Housing. Take the Bracket and Valve off the End Housing.
4. Pry and pull the End Housing (#9) away from the Brake Assembly.

CAUTION - Be careful not to damage the sealing lip of Oil Seal (#160) when removing the End Housing.

5. Remove and discard O-Ring (#30) from Piston Housing (#10) shoulder.
6. Remove the Brake Stack from the Hub (#2) spline and Piston Housing (#10) braking lugs.

NOTE - When removing the Brake Stack always keep the Drive Plates and Friction Discs in the same order as they were removed.

7. Remove the (2) Sight Gauges (#46) from the End Housing (#9) for cleaning.

The following Sections 7-3, 7-4 and 7-5 requires the motor brake to be removed from the drive motor.

7-4 HUB (#2) REMOVAL AND DISASSEMBLY

1. Pull the Hub (#2) straight up and out of the Brake Assembly. Be careful not to damage the sealing lip of Oil Seal (#31).

2. Remove Bearing (#20) with a bearing puller if it needs replaced.
3. Check the Wear Sleeves (#32) and (#86). If they are damaged, remove them with the following procedure. (See Figure 7.3)
 - a. Place the Hub (#2) into appropriate V-Block Support.
 - b. Make several notches in the Wear Sleeves with a chisel the same width as the Wear Sleeve.
 - c. The Wear Sleeves can now be removed from the hub by hand.

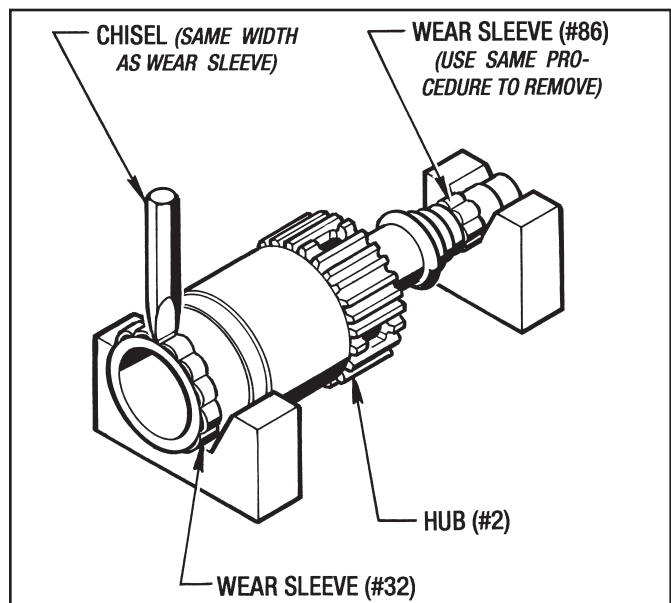

Figure 7.3 - Removing Wear Sleeves

7-5 PISTON HOUSING DISASSEMBLY

(See Figure 10.2)

1. Remove the (8) Screws (#151) and (8) Lockwashers (#129) from Housing (#8).
2. Pull the Piston Housing Assembly away from Housing (#8). Remove and discard O-Ring (#33).
3. Remove the (8) Screws (#72) and (8) Lockwashers (#127) from the Piston Retainer (#11).

CAUTION - Be very careful when removing these screws because this Piston Housing Assembly is under spring pressure. Evenly back the screws out to relieve the spring pressure.

4. Remove the (6) Springs (#36) from the spring pockets in the Piston (#3).

5. Remove the O-Ring (#30) from the Piston Retainer (#11) shoulder and discard it.
6. Push the Piston (#3) out of the Piston Housing (#10).
7. Remove and discard the Liner (#42) and O-Ring (#39) in the Piston Housing (#10).
8. Remove and discard the Liner (#43) and (2) O-Rings (#40) from the Piston (#3).

7-6 REMOVING OIL SEALS

1. Check Oil Seal (#160) in the End Housing (#9). If the sealing lip is damaged then press it out with an arbor press.
2. Check Oil Seal (#31) in the Housing (#8). If the sealing lip is damaged then press it out with an arbor press.

Section 8

CLEANING AND INSPECTION

8-1 CLEANING AND INSPECTION

Clean metal parts in a suitable solvent and dry with low pressure compressed air. Clean drive plates (#13) and (#18) in a solvent but **do not clean the Friction Discs (#12) in solvent**. Use only a clean, dry and lint free rag to clean these friction discs. Keep drive plates and friction discs in the same order as they were when removed. After cleaning, inspect parts for cracks, distortion, scoring, nicks, burrs or any other damage that would affect the operation of the brake.

Pay particular attention to the following:

1. Check the friction discs for wear, surfaces for scoring, galling or evidence of uneven wear.
2. Check the brake drive plates for scoring or galling. Make sure they are flat. If a perceptible ridge is worn in the drive plate where it mates with the friction disc, it should be replaced.
3. Carefully check the piston and bore surfaces for nicks, scratches, scoring or other damage which would affect operation or cause leakage.
4. Pay particular attention to the (2) Wear Sleeves (#32) and (#86) and the (2) Oil Seals (#31) and (#160). Check for any nicks, scratches or any damage that would cause leakage.

WARNING

Petroleum based cleaning solvents are extremely flammable. Open flames or smoking by any personnel in the vicinity of these solvents is extremely hazardous and MUST NOT BE PERMITTED.

8-2 REPAIR OR REPLACEMENT

A fine stone or crocus cloth may be used to remove minor surface defects from parts, if the operation or sealing action of the part is not affected. The use of coarser abrasives or other machining methods should not be attempted. Otherwise, damaged parts should be replaced.

Replacement is recommended for the following parts when needed.

1. Replace all O-rings, Liners, Wear Sleeves and Oil Seals removed during disassembly.
2. Replace Brake Discs and Drive Plates as a complete set.

Section 9 REASSEMBLY

9-1 GENERAL REASSEMBLY INSTRUCTIONS

See Figures 10.1 and 10.2 for a visual reference to all of the parts to be reassembled.

Note the following general reassembly instructions as applicable:

1. Lubricate O-Rings, Liners and Oil Seal lips with a light coating of White Grease or equivalent immediately before reassembly or installation of mating parts.
2. Use Red Loctite (#262) when installing new Wear Sleeves on the Hub.
3. The installation of bearings can be accomplished two ways. They can be heated up in an oven to 200° F. and dropped on the shaft or they can be pressed on with an arbor press.

9-2 INSTALLING OIL SEALS

(See Figure 10.2)

1. First clean the oil seal bores in the Housing (#8) and the End Housing (#9). Make sure they are clean and free of any foreign material.
2. Coat the oil seal bores with a thin coat of (Permatex #3 Sealant). Press Oil Seal (#31) into Housing (#8) and Oil Seal (#160) into End Housing (#9) with an arbor press. Be sure to clean off any excess sealant.

9-3 HUB REASSEMBLY

(See Figure 10.2)

1. Heat up the Bearing (#20) in an oven to 200° F. and drop it on the Hub (#2) or press it on to the Hub (#2) with an arbor press until it seats against the shoulder. (See Figure 9.1)

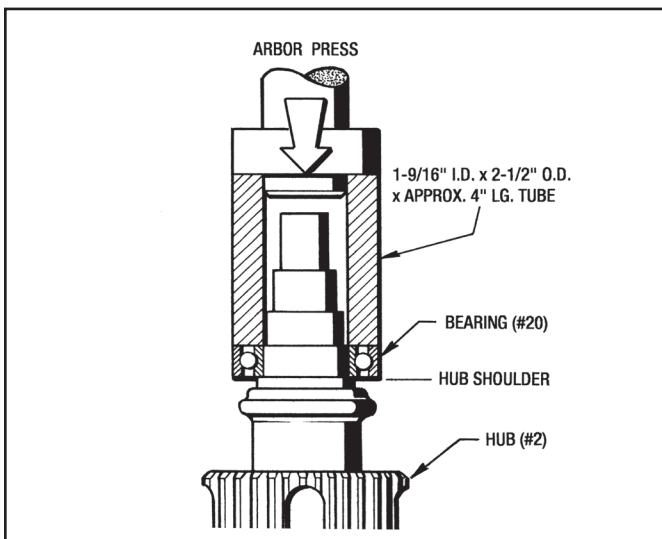

Figure 9.1 - Installing Bearing (#20)

CAUTION - Be sure to wear gloves when handling heated parts

2. Apply Red Loctite #262 to the hub diameter and press the Wear Sleeve (#32) on to the Hub (#2) as shown in Figure 9.2.

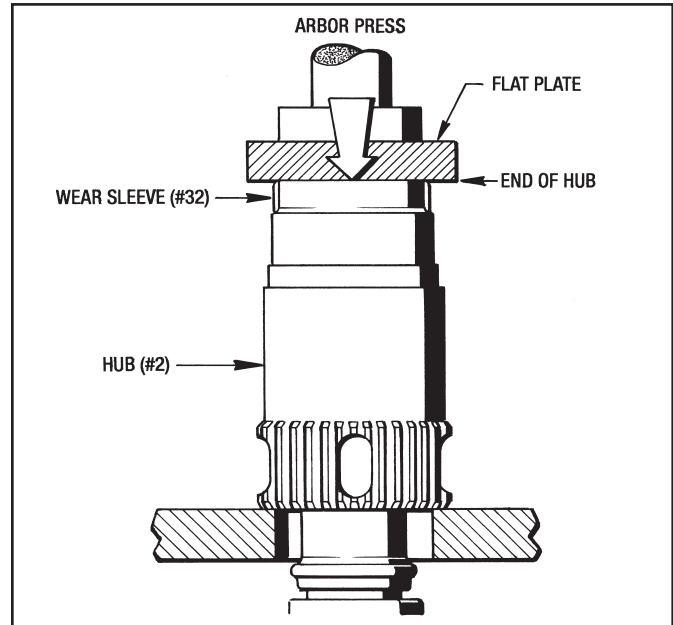

Figure 9.2 - Installing Wear Sleeve (#32)

A **Special Assembly Tool** is necessary to install the Wear Sleeve (#86) on to the Hub (#2). Dimensions and material specifications are given in Figure 9.3 if you prefer to make your own. It can also be ordered from the Besser Company with the **Part Number 114805**.

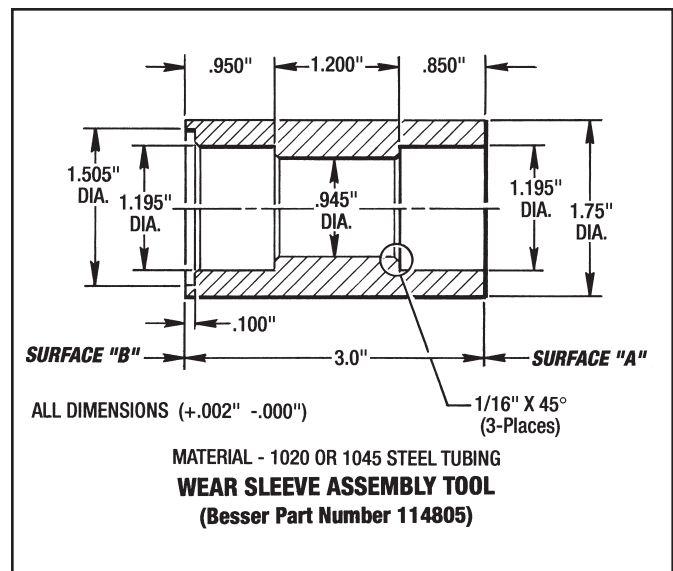

Figure 9.3 - Wear Sleeve Assembly Tool

3. Apply Red Loctite #262 to the hub diameter and with **Surface "A"** of the **Assembly Tool (#114805)** press the **Wear Sleeve (#86)** flush with the hub shoulder as shown in **Step 1** in Figure 9.4.

Turn the **Assembly Tool (#114805)** over and with **Surface "B"** finish seating the **Wear Sleeve (#86)** until it bottoms out. (See **Step 2** in Figure 9.4)

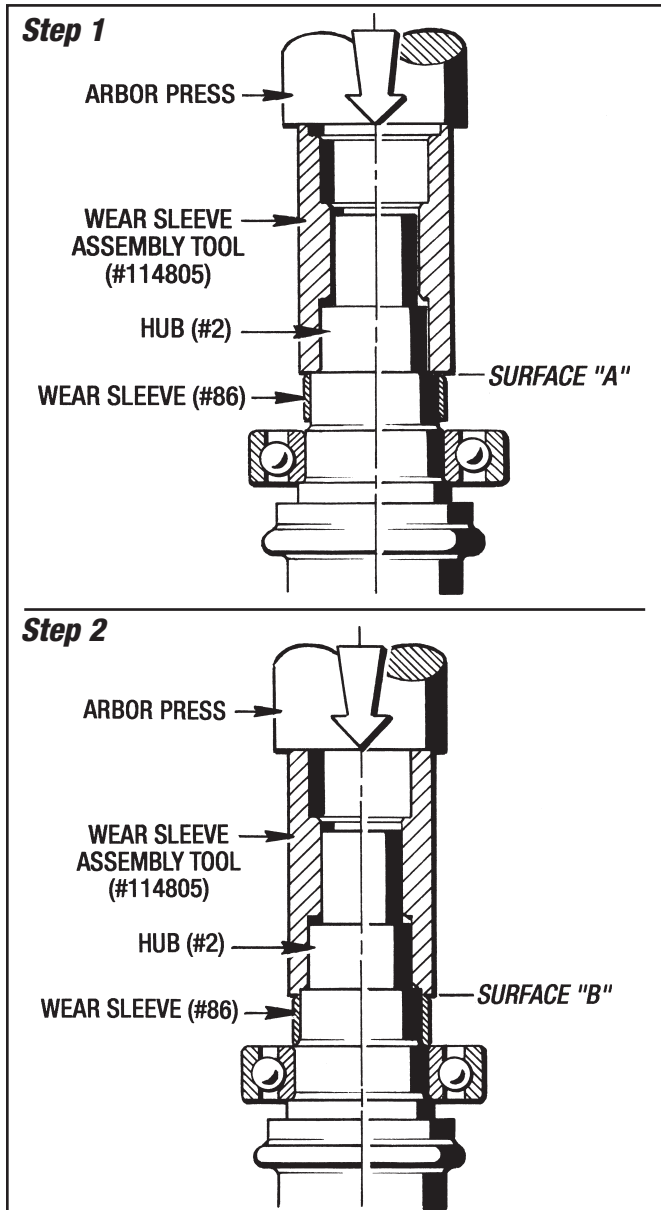

Figure 9.4 - Installing Wear Sleeve (#86)

9-4 PISTON HOUSING ASSEMBLY

(See Figure 10.2)

1. Lubricate the O-Ring (#39) and the Liner (#42) and install them into the Piston Housing (#10).
2. Lubricate the (2) O-Rings (#40) and install them into the Piston (#3).
3. Install the Liner (#43) on to the Piston (#3).

4. Place the Piston Housing (#10) flat on the table with the brake lugs pointed down.
5. Apply a light coat of White Grease or equivalent to the Liner (#42) installed in the Piston Housing (#10) and the Liner (#43) on the Piston (#3).

6. Place the Piston (#3) into the Piston Housing (#10). **Be very careful not to damage the (2) Teflon Liners (#42) and (#43).**

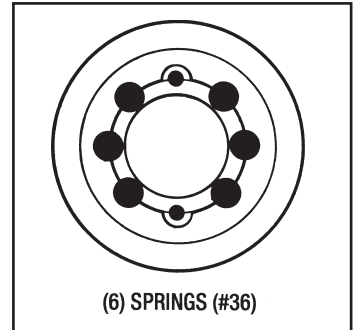

7. Place the (6) Springs (#36) into the Piston (#3) spring pockets as shown in Figure 9.5.

8. Lubricate the O-Ring (#30) with White Grease or equivalent and place it on the Piston Retainer (#11).

9. Bolt the Piston Retainer (#11) to the Piston Housing (#10) with (8) Screws (#72) and (8) Lockwashers (#127). **Torque to 37 Ft. Lbs.**

NOTES:

1. Make sure the 1/4" NPT hole for shop air is located at the bottom to prevent condensation from accumulating in the piston chamber.
2. Fasten these (8) Screws down in an even manner to correctly compress the Springs (#36).
10. Lubricate the O-Ring (#33) with White Grease or equivalent and place it on the Piston Retainer (#11) shoulder.
11. Set the Housing (#8) on the Piston Retainer (#11) and attach with (8) Screws (#151) and (8) Lockwashers (#129). **Torque to 37 Ft. Lbs.**

9-5 INSTALLING HUB (#2)

(See Figure 10.2)

1. Turn the Brake Assembly over with the Piston Housing brake lugs pointed up.
2. Apply a light coat of White Grease or equivalent to the Wear Sleeve (#32). This will facilitate sliding the Hub into the Oil Seal (#31).

IMPORTANT: Use special care not to damage the oil seal lip when inserting the hub into the brake assembly.

3. Insert the Hub (#2) down and into the Oil Seal (#31). Make sure the Hub (#2) stays in a vertical position.

9-6 INSTALLING SEPARATOR SPRINGS

(See Figure 10.2)

Vibrator Drive Motor Brakes require the use of separator springs. They are used to prevent residual drag and to improve cooling.

1. Install (4) Separator Springs (#17) on each Drive Plate (#18). (See Figure 9.6) The springs just snap over the large end of the rivets.

NOTE: Do not install Separator Springs (#17) on the Drive Plate (#12).

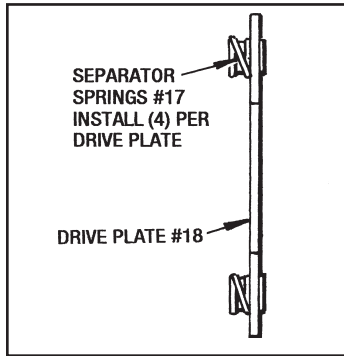

Figure 9.6 - Separator Springs

9-7 INSTALLING BRAKE STACK

(See Figure 10.2)

1. Apply 60 to 80 PSI to the 1/4" NPT brake port at the bottom of the Piston Housing (#10) so the Piston (#3) will retract fully.
2. While the air pressure is being applied, install the Brake Stack as shown in Figure 9.7.

Install a Drive Plate (#18) with the Separator Springs (#17) pointing up. Then a Friction Disc (#12). Install a total of (5) Drive Plates (#18) and (5) Friction Discs (#12). Then install a Drive Plate (#12) which has no Separator Springs on it.

NOTE: Align the teeth in the Friction Discs (#12) with the spline teeth on the Hub (#2) and the notches in the Drive Plates (#18) and (#12) with the lugs on the Piston Housing (#10).

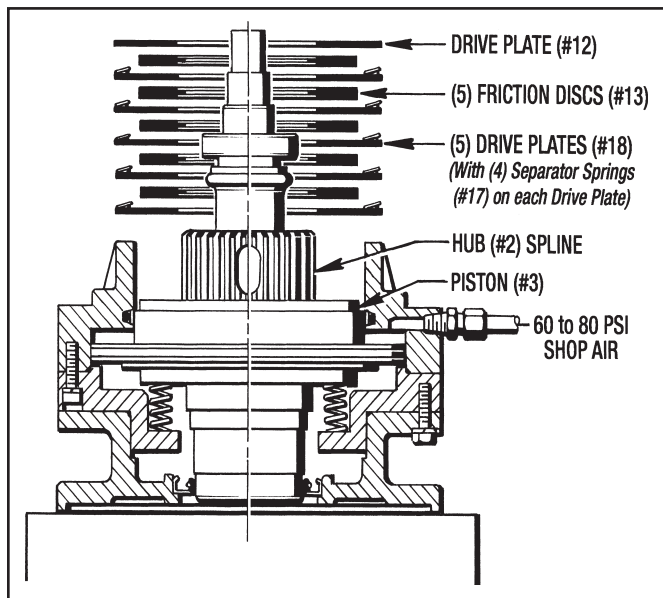

Figure 9.7 - Brake Stack Arrangement

9-8 INSTALLING END HOUSING (#9) TO BRAKE ASSEMBLY

(See Figure 10.1 and 10.2)

1. Lubricate O-Ring (#30) with a light coat of White Grease or equivalent and place it on the Piston Housing (#10).
2. Slide the End Housing (#9) down over the Hub (#2) until the Bearing (#20) seats in the bearing bore.

CAUTION: Be very careful not to damage the sealing lip of Oil Seal (#160) installed in the End Housing.

NOTE: Make sure the breather hole is located at the top.

3. Attach the End Housing with (6) Screws (#72) and (6) Lockwashers (#127). **Torque to 25 Ft. Lbs.**

NOTE: Leave the (2) mounting holes empty where the Mounting Bracket (#271) attaches to. (See Figure 9.8)

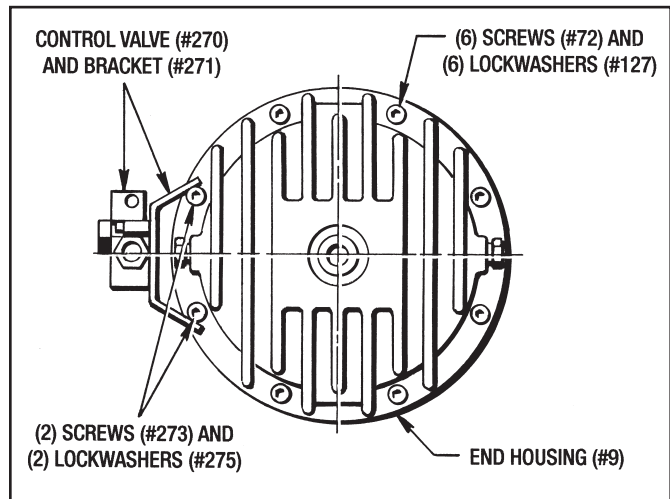

Figure 9.8 - Attaching End Housing (#9)

4. Install the Sight Gauge (#46) on the L.H. side of the End Housing (#9).
5. Attach the Mounting Bracket (#271) with (2) Screws (#273) and (2) Lockwashers (#275). **Torque to 25 Ft. Lbs.**
6. If the Control Valve (#270) was removed then attach it to the bracket with (2) Screws (#272) and (2) Lockwashers (#274).

It is safe now to release the piston air pressure.

9-9 INSTALLING COOLING FAN (#25)

(See Figures 9.9 and 10.2)

1. Make sure the ID of the Clamping Ring (#331) and the mating surface of the Hub (#2) is thoroughly clean of any oil or grease.
2. Apply **Loctite Primer T** and **Blue Loctite #242** to the OD of the Hub (#2) and the threads of the Screw in the Clamping Ring (#331).
3. Position the Clamping Ring (#331) on the Hub (#2) so it is flush with the Hub (#2) shoulder as shown in Figure 9.9.

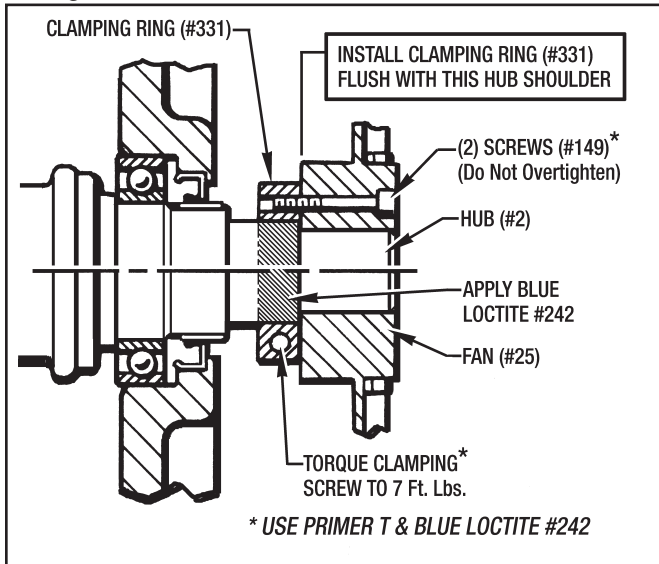

Figure 9.9 - Installing Cooling Fan (#25)

9-10 INSTALLING THE BRAKE ASSEMBLY TO THE DRIVE MOTOR

Attach the Brake Assembly to the Drive Motor as per instructions given in **Section 3 - INSTALLATION**.

9-11 FINAL REASSEMBLY PROCEDURE

(See Figures 10.1 and 10.2)

1. Re-attach Fan Shroud (#24) with (4) Screws (#166) and (4) Lockwashers (#167).
2. Replace the other Sight Gauge (#46) on the R.H. side and Drain Plug (#74) back into the End Housing (#9).

Also replace the Pipe Nipple (#77) and Pipe Cap (#67) back into the Housing (#8) if they were removed.

3. Fill the unit with fresh fluid as directed in **Section 4 - LUBRICATION**.
4. Connect any hoses or fittings from the Control Valve as shown on Figure 10.1.

Reconnect electrical connections to the valve solenoid.

Hookup 60 to 80 PSI shop air to the control valve.

5. Make an Operational Check as specified in Section 5.
6. Reinstall Reducer Bushing (#76) and Air Breather (#45) into the top of the End Housing (#9).

Reassembly and Installation is now complete and your BESCOSTOP Motor Brake is ready for service.

NOTES

Section 10

ORDERING REPAIR PARTS

10-1 GENERAL INFORMATION

This section lists, describes and illustrates all available repair parts for the BESCOSTOP Motor Brake.

The models covered in this manual is the MB-280-223 and MB-280-238.

Parts are identified on the exploded view drawings (Figure 10.1 and 10.2) with Reference Numbers. These numbers are the same as used in the parts listing.

10-2 ORDERING MAJOR and MINOR REPAIR PARTS KITS

Contact the Besser Central Order Department when ordering any repair parts, please specify all of the following information:

1. **COMPLETE MODEL NUMBER** (On Name plate).
2. **SERIAL NUMBER** (On Name plate).
3. **PART REFERENCE NUMBER** (From Parts List and Exploded View Drawing).
4. **PART NAME** (From Parts List).
5. **QUANTITY** (As Required).
6. **COMPLETE SHIPPING INFORMATION**

10-3 NAME PLATE INFORMATION

(This Name Plate is located on the Piston Housing.)

IMPORTANT

Failure to include all of the specified information will only delay your parts order. Unless another method is specified for Shipping Information, parts weighing less than 150 lbs. will be shipped United Parcel Service. Parts weighing over 150 lbs. will be shipped motor freight. Air freight and other transportation services are available but only if specified on your order.



10-4 FACTORY REBUILD SERVICE

Reconditioning Service is offered by Force Control exclusively through the Besser Company. Before returning any unit to Force Control, contact the Besser Company Central Order Department for shipping instructions and order processing. The Besser Company will arrange proper authorization from Force Control for return of the unit(s) for repair. Neither Force Control or the Besser Company can be responsible for any units returned without first following the procedures outlined.

Care must be given to the packaging of returned units. Always protect mounting feet and flanges by attaching to a suitable skid. Shipment-damaged units always delay repairs. It usually impossible to recover damage costs from the carrier. Whenever possible describe the problems you are having with your motor brake on your shipping papers.

Return To: **Force Control Industries, Inc.**

Contact the Besser Central Order Department for a complete return address.

 BESCOSTOP 	
MODEL NO. <input style="width: 200px; height: 15px;" type="text"/>	USE MOBIL® ATF 210
SERIAL NO. <input style="width: 200px; height: 15px;" type="text"/>	
MFR. BY: FORCE CONTROL INDUSTRIES, INC. FOR: BESSER CO.	

10-5 Repair Parts List

MB-280-238 *BESCOSTOP™* Motor Brake

BESSER P/N 113759

Ref. No.	Part Name	Qty.	Ref. No.	Part Name	Qty.
2	Hub	1	110	Collet	1
3	Piston.....	1	125	90° Elbow, 1/4" NPT	1
8	Housing.....	1	127	Lockwasher, 3/8".....	16
9	End Housing	1	128	Lockwasher, 1/2".....	4
10	Piston Housing.....	1	129	Lockwasher, 3/8".....	8
11	Piston Retainer	1	131	Pipe Plug, 1/4" NPT.....	1
**12	Drive Plate	1	149	Soc. Hd. Screw, #10-24 x 1" Lg.....	2
**13	Friction Disc	5	150	Hex Hd. Screw, 1/2"-13 x 1-1/2" Lg.....	4
**17	Separator Spring.....	20	151	Hex Hd. Screw, 3/8"-16 x 1-1/4" Lg.....	8
**18	Drive Plate with rivet	5	158	Dowel Pin, 3/8" Dia. x 3" Lg.	1
*20	Bearing	1	*160	Oil Seal	1
24	Fan Shroud	1	166	Hex Hd. Screw, 1/4"-20 x 1/2" Lg.....	4
25	Fan	1	167	Lockwasher, 1/4".....	4
*30	O-Ring	2	168	Lockwasher, 3/8".....	1
*31	Oil Seal.....	1	209	Flow Control Valve	1
*32	Wear Sleeve	1	263	Pipe Nipple	1
*33	O-Ring	1	270	Control Valve (Complete).....	1
*36	Spring	6	270B	Valve Spool.....	1
*39	O-Ring	1	270C	Pilot Valve Assembly (Includes Solenoid) ...	1
*40	O-Ring	2	271	Mounting Bracket.....	1
*42	Liner	1	272	Soc. Hd. Cap Screw	2
*43	Liner	1	273	Soc. Hd. Cap Screw.....	2
*45	Air Breather.....	1	274	Lockwasher.....	2
*46	Sight Gauge.....	2	275	Lockwasher.....	2
67	Pipe Cap, 1/8" NPT.....	1	276	Hose	1
71	Pipe Nipple, 1/4" x 1-1/2".....	1	277	Hose Fitting.....	1
72	Soc. Hd. Screw, 3/8"-16 x 1-1/4" Lg.....	16	278	Hose Fitting.....	1
74	Sq. Hd. Mag. Pipe Plug, 1/4" NPT.....	1	280	Swivel Adapter.....	1
76	Reducer Bushing, 1/2" x 1/4" NPT.....	1	281	Street Elbow	1
77	Pipe Nipple, 1/8" x 2" Lg.....	1	282	Bronze Muffler	1
78	Sq. Hd. Pipe Plug, 1/4" NPT	1	331	Locking Collar	1
*86	Wear Sleeve	1	901	Assembly Tool.....	1
94	Hub Locking Screw, 5/8"-11 x 8" Lg.....	1			

* - Indicates Parts in Rebuild Kit #74-280-238 (Also Includes all parts on Stack Kit).

** - Indicates Parts in Stack Kit #72-280-238.

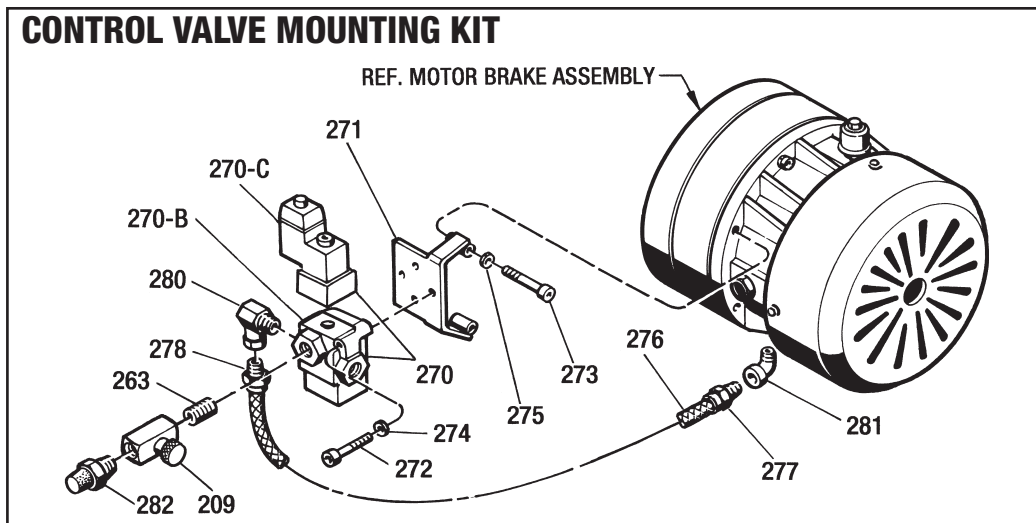
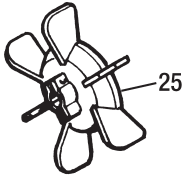

Figure 10.1 - Control Valve Mounting Kit

BESCOSTOP™ Motor Brake

(Model No. MB-280-238)

Model 280-223 Only



THIS TYPE FAN IS NO LONGER AVAILABLE

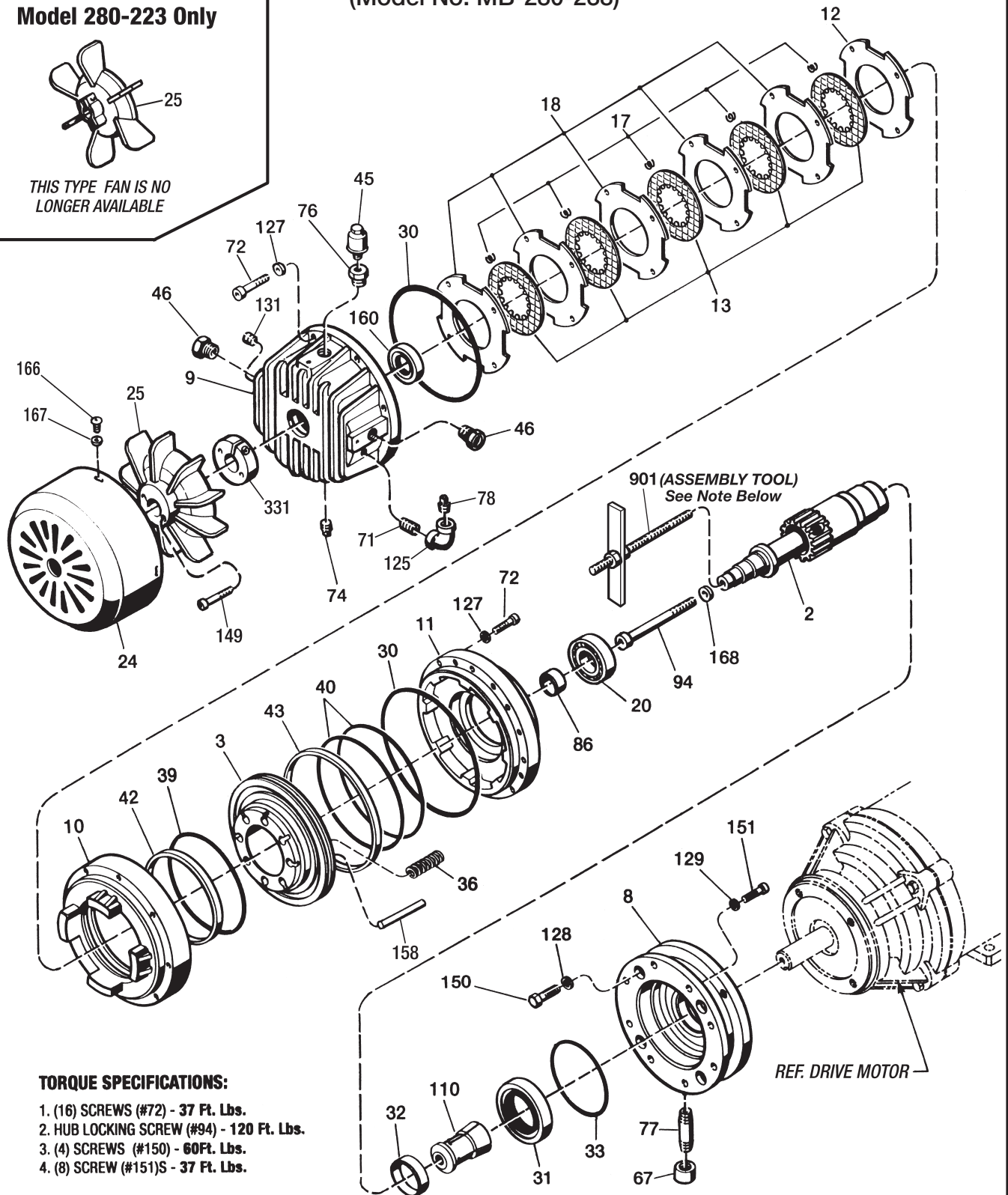

TORQUE SPECIFICATIONS:

1. (16) SCREWS (#72) - 37 Ft. Lbs.
2. HUB LOCKING SCREW (#94) - 120 Ft. Lbs.
3. (4) SCREWS (#150) - 60Ft. Lbs.
4. (8) SCREW (#151)S - 37 Ft. Lbs.

NOTE - Besser Part Number for (#901) Assembly Tool is #114807

Figure 10.2 - Bescostop Motor Brake

BESCOSTOP™ Oil Shear Motor Brakes

*Providing today's industries
with Oil Shear Clutch and
Brake Drives that deliver...*

- *Flexibility*
- *Efficiency*
- *Endurance*
- *Performance*
- and • *Dependability*

"BUILT TO LAST - GUARANTEED TO PERFORM"

MANUFACTURED FOR:

BESSER COMPANY

Phone - (989) 354 - 4111

801 Johnson Street

P.O. Box 336

Alpena, Michigan 49707 U.S.A.

MANUFACTURED BY:



FORCE CONTROL INDUSTRIES, Inc.

Fairfield, Ohio



MEX (55) 53 63 23 31 MTY (81) 83 54 10 18
QRO (442) 1 95 72 60 ventas@industrialmagza.com