



502-CLPC LC-001-00

# **CLPC™ Control Model LC**

## **Closed Loop Position Control**

# **OPERATION AND SERVICE MANUAL**

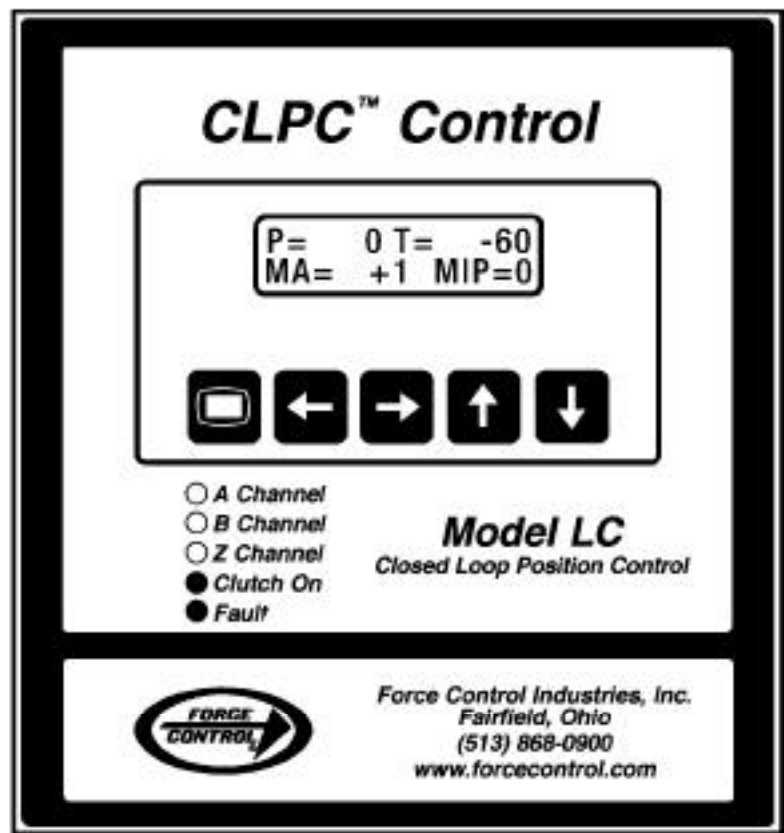

**FORCE CONTROL INDUSTRIES, INC.**

**WARNING - Read this manual before any installation, maintenance and operation.**

**MANUFACTURERS OF MECHANICAL AND ELECTRICAL POWER TRANSMISSION EQUIPMENT.**

## Limited Warranty

Force Control Industries, Inc. ("Force Control") warrants its products to be free from defects in material and workmanship under normal and proper use for a period of one year from the date of shipment. Any products purchased from Force Control that upon inspection at Force Control's factory prove to be defective as a result of normal use during the one year period will be repaired or replaced (at Force Controls' option) without any charge for parts or labor. This limited warranty shall be void in regard to (1) any product or part thereof which has been altered or repaired by a buyer without Force Control's previous written consent or (2) any product or part thereof that has been subjected to unusual electrical, physical or mechanical stress, or upon which the original identification marks have been removed or altered. Transportation charges for shipping any product or part thereof that the buyer claims is covered by this limited warranty shall be paid by the buyer. If Force Control determines that any product or part thereof should be repaired or replaced under the terms of this limited warranty it will pay for shipping the repaired or replaced product or part thereof back to the buyer. EXCEPT FOR THE EXPRESS WARRANTY SET OUT ABOVE, FORCE CONTROL DOES NOT GRANT ANY WARRANTIES EITHER EXPRESSED OR IMPLIED, INCLUDING IMPLIED WARRANTIES OF MERCHANTABILITY OR FITNESS FOR USE. The warranty obligation set forth above is in lieu of all obligations or liabilities of Force Control for any damages. Force Control specifically shall not be liable for any costs incurred by the buyer in disconnecting or re-installing any product or part thereof repaired or replace under the limited warranty set out above. FORCE CONTROL EXPRESSLY EXCLUDES ALL LIABILITY FOR ANY INDIRECT OR CONSEQUENTIAL DAMAGES THE BUYER MAY SUSTAIN IN CONNECTION WITH THE DELIVERY, USE, OR PERFORMANCE OF FORCE CONTROL PRODUCTS. Under no circumstances shall any liability for which Force Control is held responsible exceed the selling price to the buyer of the Force Control products that are proven to be defective. This limited warranty may be modified only in writing signed by a duly authorized officer of the company. This limited warranty applies exclusively to Force Control products; warranties for motors and gear reducers and other component parts may be provided by their respective manufactures. Any legal action for breach of any Force Control warranty must be commenced within one year of the date on which the breach is or should have been discovered.

A Return Goods Authorization (RGA) number must be obtained from the factory and clearly marked on the outside of the package before any equipment will be accepted for warranty work. Force Control will pay the shipping costs of returning the owner parts that are covered by warranty.

Force Control believes that the information in this document is accurate. The document has been carefully reviewed for technical accuracy. In the event that technical or typographical errors exist, Force Control reserves the right to make changes to subsequent editions of this document without prior notice to holders of this edition. The reader should consult Force Control if errors are suspected. In no event shall Force Control be liable for any damages arising out of or related to this document or the information contained in it.

# Table of Contents

## Section 1 - INTRODUCTION

1-1 Theory of Operation	1
1-2 Typical Applications	1
A. Single Revolution	1
B. Partial Revolution	1
C. Multiple Revolution	2
1-3 CLPC LC Control Features	2
1-4 Components in a Typical System	2
A. CLPC LC Control	2
B. Encoder	2
C. Home Sensor	2
D. Actuation Output (Solenoid Valve Actuator)	3
E. Start Cycle (PLC Interface)	3

## Section 2 - GENERAL SPECIFICATIONS

2-1 General Specifications Chart	4
----------------------------------	---

## Section 3 - INSTALLATION

3-1 Receiving and Unpacking Parts	5
3-2 Mounting CLPC LC Control	5
Mounting Template	6
3-3 Mounting Optional Junction Box	7
3-4 Mounting External Encoder	8
3-5 Mounting External Home Sensor	8
3-6 Electrical Connections	8
A. Type of Wiring for Encoder Connections	8
B. Wire Paths	8
C. Max. Wire Length	8
3-7 Main Power to CLPC LC Control	8
3-8 Terminal Block J1 (Main Power Supply to the CLPC LC control)	8
3-9 Terminal Block J2 (Inputs and Outputs)	9
PLC to CLPC LC (AC Start Cycle) Schematic	9
PLC to CLPC LC (DC Start Cycle) Schematic	10
Cycle Start/Hand Off Auto/Single Index (115 VAC)	10
Cycle Start/Hand Off Auto/Single Index (Customer Supplied 24 VDC)	11
Abort Cycle	11
3-10 Terminal Block J3	12
A. CLPC LC Control to Optical encoder with Internal Home Sensor	12
B. CLPC LC Control to Optical encoder with External Home Sensor	12
C. CLPC LC Control to Optical encoder with External Photo Sensor	13
D. Program Lock	13
3-11 Terminal Block J4 (Optional PLS Outputs and MIP Inputs)	13
A. Capabilities	13
B. Programming	14
Menu Parameters #16 to #23 - PLS Outputs	14
Menu Parameters #24 to #71 - MIP Inputs	14
3-12 MIP Group Worksheet	15
3-13 CLPC LC Control to Junction Box	16
3-14 Junction Box to Actuation Valves and Optical Encoder	17
A. With Internal Home Sensor (Channel Z)	17
B. With External Home Sensor (Channel Z)	18
C. With External Home Photo Sensor (Channel Z)	19

# Table of Contents (Concluded)

## Section 4 - START-UP & OPERATION

4-1 Front Panel Description	20
A. Display	20
B. Push Buttons	20
C. Diagnostic Indicator Lights	20
4-2 Operating Modes	20
A. Run Mode	20
B. Program Mode	20
List - Menu Parameters for Standard Control	21
4-3 Initial Set-Up procedure	21
Menu Parameter #1 - Max Count	22
4-4 Remaining Parameter Descriptions	22
Menu Parameter #2 - Manual Adjust	23
Menu Parameter #3 - IP Window	23
Menu Parameter #4 - Stall Detection	23
Menu Parameter #5 - Watch Dog Timer	23
Menu Parameter #6 - Encoder Multiplier	24
Menu Parameter #7 - Encoder Wiring	24
Menu Parameter #8 - Encoder Sense	24
Menu Parameter #9 - Home Wiring	24
Menu Parameter #10 - Home Sense	24
Menu Parameter #11 - Control Mode	24
Menu Parameter #12 - No Motion Timer	25
Menu Parameter #13 - Input Debounce	25
Menu Parameter #14 - Version	25
Menu Parameter #15 - Node Number	25

## Section 5 - TROUBLE SHOOTING

5-1 Power-Up Sequence	26
5-2 Description of Front Panel	26
A. Display	26
B. Push Buttons	26
5-3 Error Codes	26
A. General Procedure to Change Parameter Settings	26
B. Error Codes & Corrections	27
5-4 Other Error Display	28
5-5 Trouble Shooting Areas	28
A. Drive Will Not Index	28
B. Drive Stops Out Of Position (Same position each time)	28
C. Drive Stops Out Of Position (Different position each time)	29
D. Drive Does Not Stop	29
5-6 Operational Sequence	29

## Section 6 - REPAIR & REPLACEMENT

6-1 Removal and Disassembly of Optical Encoder	30
6-2 Reassembly and Installation of Optical Encoder	30

## Section 7 - ORDERING REPAIR PARTS

7-1 General Information	33
7-2 Factory Rebuild Service	33
7-3 Ordering Repair Parts	33
7-4 CLPC LC Control Model Numbers	34
7.5 CLPC LC Unit Sticker	34

## REPAIR PARTS

Figure 7.1 - CLPC LC Control	35
Figure 7.2 - Optional Junction Box	36
Figure 7.3 - Optical Encoder (Sizes 01 to 05 <i>Posidyne</i> )	37
Figure 7.4 - Optical Encoder (Sizes 10 to 20 <i>Posidyne</i> )	38

CLPC LC Software/Firmware Revision History	39
--	----

# Section 1 - INTRODUCTION

## 1-1 THEORY OF OPERATION

Clutch/Brakes have been used for many years to index to position for feeding, cutting, packing, etc. Through the years the consistency of clutch/brakes to stop in position has improved some, but not to a great extent. The multiple disc, oil shear **Posidyne Clutch/Brake** has been a leader in dependable and accurate positioning drive systems. The **Oil Shear System** lubricates and cools the friction surfaces creating an environment which maintains a very consistent coefficient of friction. Therefore the transmitted torque is very consistent.

Here in lies the problem. Most machine drives are required to operate under varying loads, speeds, or other variable conditions. Therefore even with a very consistent torque the acceleration and deceleration time can vary causing inaccuracies in position. Various attempts have been tried to better control positioning accuracy. Adjustable limit switches or proximity switches have been tried, but need to be manually adjusted. On newer equipment the PLC is often used to read an encoder and stop the drive at the proper time. There are several problems with this system. (1) The scan time of the PLC, even though only 20 to 40 milliseconds, can be enough to cause different stop positions on high speed applications. (2) Unless a very sophisticated feed back loop system is designed the PLC still has no way to correct for varying conditions.

The **CLPC LC** Closed Loop Positioning Control developed by Force Control Industries, Inc. uses an encoder and home sensor to continually look at the stopping position, compare it to the actual home position and make corrections as errors begin to occur.

There are several types of applications which can utilize the **CLPC LC** Closed Loop Positioning Control.

## 1-2 TYPICAL APPLICATIONS

**A. Single Revolution** - Two typical applications for a single revolution operation would be a Rotary Cut-off and a Shingle Catcher. (See Figure 1.1)

In these applications the final shaft turns one revolution each index cycle. In most cases it is critical that the blade reach the same point at the same time in the cycle for accurate cut length. Here the acceleration rate as well as the stop position are critical for consistency. On these applications usually the index length, once set, never changes.

**B. Partial Revolution** - These are applications such as a case packer or dial table where each index is a preset number of degrees. In these applications the stop position is critical to prevent jams. Also the index length is

seldom changed, however it could be if a tooling change changed the number of stops. (See Figure 1.2)

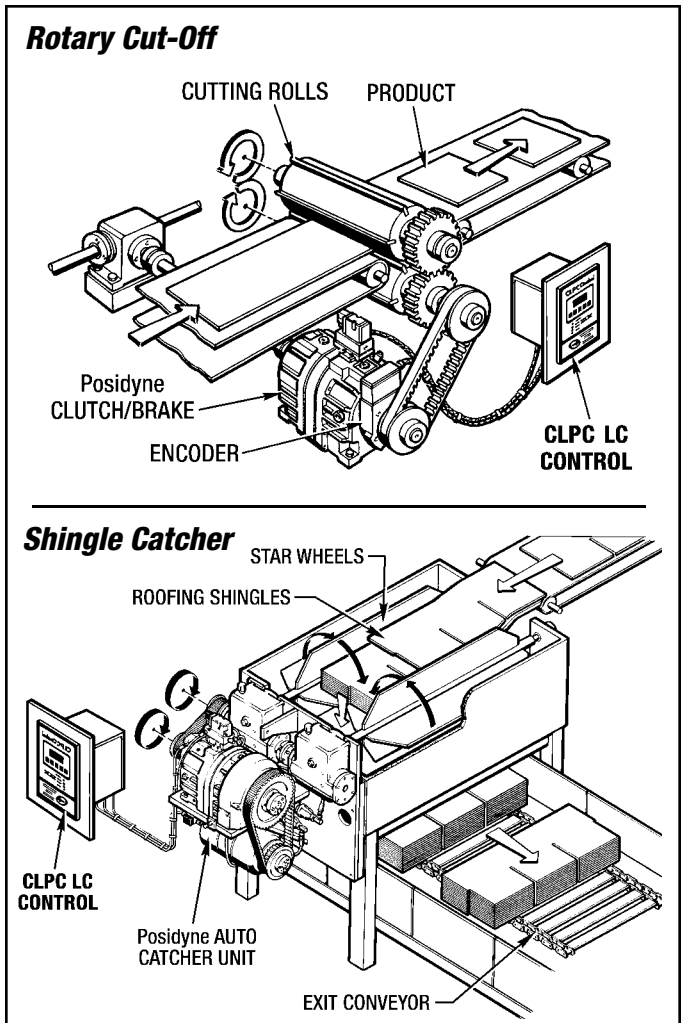

Figure 1.1 - Single Revolution Applications

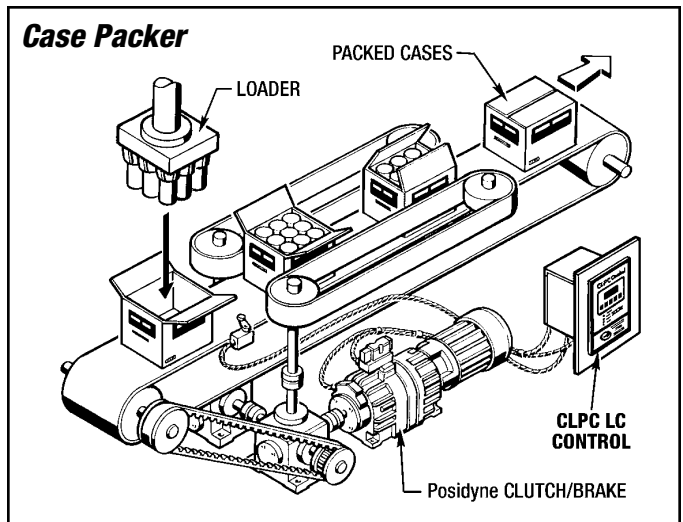

Figure 1.2 - Partial Revolution Application

**FORCE CONTROL INDUSTRIES, INC.**



MEX (55) 53 63 23 31 MTY (81) 83 54 10 18  
QRO (442) 1 95 72 60 ventas@industrialmagza.com

**C. Multiple Revolution** - These are applications such as feeding steel for cut to length or plastic film for making plastic bags.

This application requires the ability to change the index length for each product change. A product is fed with nip rolls to feed a preset length of product. (See Figure 1.3)

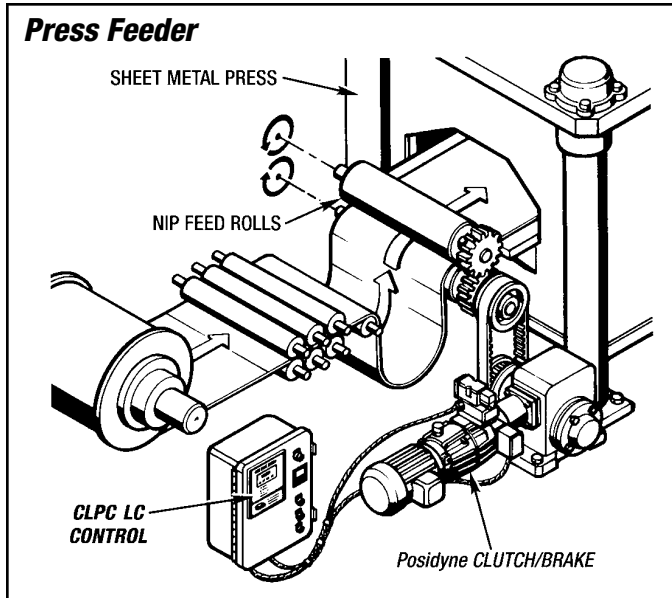

Figure 1.3 - Multiple Revolution Application

### 1-3 CLPC LC CONTROL FEATURES

- **Universal Supply Input** - 85-264 VAC, 47-63 Hz., Single phase, 100 Watts max.
- **Interface** - All functions adjustable with a simple menu through a display panel.
- **Program Lockout** - via external cold contact.
- **Eleven Internally Tested Functions** - Error Codes with descriptions displayed to identify Faults.
- **Compact Design** - Door Mount or Panel Mount.
- **Always Ready** - No calibration required.
- **Stall Detection** - Detects a jam (no rotation of the encoder) before reaching the trigger point and disengages the clutch.
- **Watch Dog Timer** - Adjustable (100 milliseconds to 1 minute) timer which will disengage the clutch if timed out before reaching the desired stop position. Used to protect against jams which may stop or slow down the drive.
- **Encoder Resolution Settings** - X1, X2 and X4.
- **Manual Adjustment** - Allows a positive or negative adjustment from the home sensor position. Used to align the machine position with the home sensor.
- **Abort/Discontinue Cycle** - Abort Input allows the control to react to an external request to stop the index or prevent any further indexes from occurring. The CLPC LC will not adjust the trigger point or abort-cycle.

■ **In Position Output** - An output to indicate when the drive has reached position. A plus or minus count can be set as an allowable in position window.

■ **Optional (MIP/PLS)** - Multiple Indexing Parameter groups - Capable of storing up to 16 different groups (Index Distances). Programmable Limit Switch - Capable of 4 Programmable Outputs based on position.

### 1-4 COMPONENTS IN A TYPICAL SYSTEM

(See Figure 1.4)

#### A. CLPC LC Control

The **CLPC LC** Closed Loop Positioning Control is an electronic, error correcting, closed loop positioning control used to control the **Posidyne Clutch/Brake** in a positioning or feed to length application. It can also be used to operate other types of clutch/brake and brake motor units.

Upon a signal from the machine control the **CLPC LC** Control will energize the actuation valve solenoid from a 24 VDC output to engage the clutch and allow the drive to run until a preset trigger point is reached, at which time the valve solenoid is de-energized engaging the brake to stop the drive in position.

#### B. Encoder

The **CLPC LC** Control operates by counting pulses using a quadrature pulse train generated by an incremental encoder to determine actual position and facilitate stopping position. The control will recognize various types of encoders, however they must meet the following specifications:

1. Sinking open collector output.
2. RS 422 / RS 485 differential output.
3. 5 to 12 Volts DC.
4. Either single ended, open collector output or differential line driver.
5. TTL compatible: 0-3 VDC (Low), 2-12 VDC (High)

The number of pulses per revolution or resolution is determined by the location of the encoder, accuracy of the stopping position required and the accuracy of the drive train. Resolution must be high enough to be accurate without being overly fine with no actual positioning benefit. The closer the encoder to the final shaft the higher resolution required.

#### C. Home Sensor

The **CLPC LC** Closed Loop Positioning Control requires a home sensor to indicate where the mechanical home of the drive is located. This can be any kind of a single pulse generated from a limit switch, proximity switch, optical limit switch, Z pulse encoder, etc. The duration of

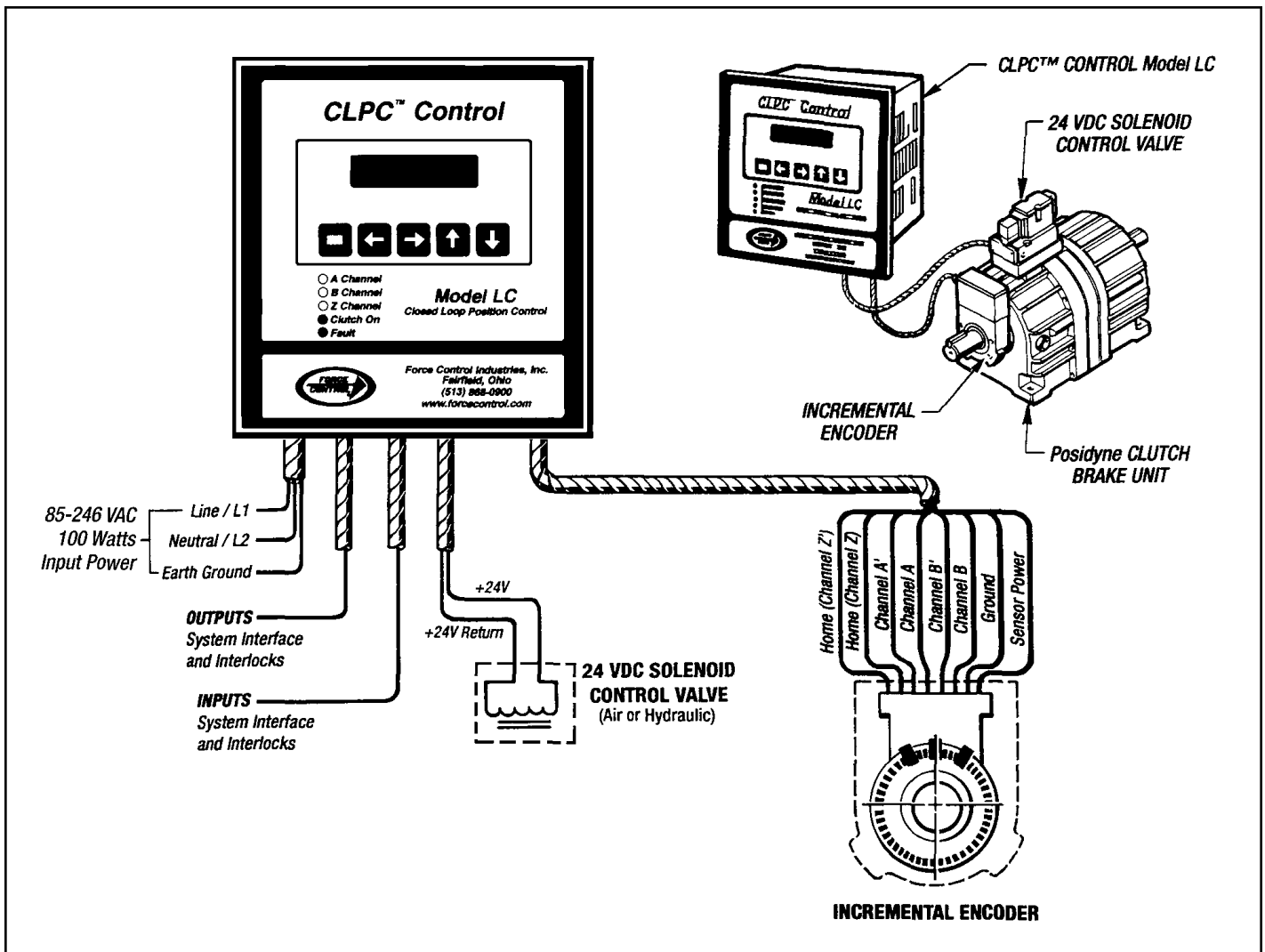

Figure 1.4 - CLPC-LC Typical System

the pulse must be at least 15 milliseconds and meet the following specifications:

1. Output saturation (voltage drop across conducting sensor) to be a maximum of 1.0 Volts @ 50 milliamps if single ended.
2. Normally open (NO) or normally closed (NC).
3. NPN Sinking.
4. 3 wire.
5. TTL compatible. 0-.3 VDC (Low), 2-12 VDC (High)
6. If a Limit Switch is used it may need a capacitor. (Typical Value of the capacitor would be 10  $\mu$ F, 35 V.) Contact factory for further assistance.

#### D. Actuation Output (Solenoid Valve Actuator)

The **CLPC LC** Closed Loop Positioning Control has a direct actuation output which is 24 VDC, at a maximum of

1 Amp. The **Posidyne** actuation valve solenoid is typically 24 VDC, 12.7 Watts.

#### E. Start Cycle (PLC Interface)

The start cycle signal required by the **CLPC LC** Control is a short pulse of 50 milliseconds in duration which can be furnished from a PLC output or other source. The required signal can be AC or DC and must be:

1. 90 to 140 VAC (typ. 115 VAC), cold contact, 50 milliseconds minimum in duration with 6 to 10 milliamps input current and 2.5 milliamps drop out current.
2. 10 to 30 VDC (typically 24 VDC) and 50 millisecond minimum in duration.

# Section 2 - GENERAL SPECIFICATIONS

## 2-1 GENERAL SPECIFICATIONS CHART

<b>Electrical</b>	
<b>Input Power</b>	85-264 VAC, 47-63 Hz., Single phase, 100 watts max., Fused @ 4 amps.
<b>Encoder Input</b>	Six Signals: A, A', B, B', Z and Z'; 7.2 kHz max.; 0-.3VDC (Low), 2-12 VDC (High)
<b>Auxiliary Supply</b>	12 VDC, 1 amp, Current limited, Short circuit protected. Used for Encoder and Home Switch.
<b>Solid State Inputs</b>	Three: 120 VAC and 24 VDC standard, Fused @ 1/16 amps, - Start Cycle, Fault Reset and Abort Cycle.
<b>Program Interlock Input</b>	External cold contact switch required
<b>Solid State Outputs</b>	Two: 115 VAC standard (7 to 60 VDC available), Fused @ 3 amps, N.O. - Fault and In Position,
<b>Clutch/Brake Output</b>	One: 24 VDC, 1 amp max., Fused @ 3 amps.
<b>Displays</b>	16 characters by 2 lines, .22" character height, Backlit
<b>LED Status Indicators</b>	Five: Channel A, Channel B, Z Channel, Clutch On, Fault.
<b>Diagnostics</b>	Eleven: Internally tested functions. Error codes and description displayed to identify faults.

<b>Mechanical</b>	
<b>Enclosure</b>	Aluminum/Stainless, Black anodized, NEMA 1, IP20 Enclosure. NEMA 4, IP66 when door mounted with gasket
<b>Weight</b>	3.5 Lbs.
<b>Dimensions</b>	6" x 6" Face x 5-3/4" Deep

<b>Environmental</b>	
<b>Operating Temp.</b>	32° - 140° F (0 - 60° C)
<b>Storage Temp.</b>	0° - 186° F (-18° - 85° C)
<b>Ambient Humidity</b>	90% non-condensing max.
<b>Vibration</b>	2.5 g's, 30 to 200 Hz.

<b>Programmability</b>	
<b>Interface:</b>	All functions adjustable through display panel push buttons. Some of these Functions include:
● <b>Index Count</b>	Up to 65,535 pulses.
● <b>Manual Adjust</b>	± 1/4 of maximum count.
● <b>Encoder Input Control</b>	x1, x2 and x4 operation.
● <b>Watch Dog Timer</b>	Off, 100 ms to 1 min. in 16 increments.
<b>Push Buttons</b>	Five: Program, Menu Back, Menu Forward (Fault Reset), Increment and Decrement.
<b>Optional (MIP/PLS)</b>	Multiple Indexing Parameter Groups - Capable of storing up to 16 different groups. Programmable Limit Switch - Capable of 4 Programmable Outputs based on position.

# Section 3 - INSTALLATION

## 3-1 RECEIVING AND UNPACKING PARTS

Upon receipt of this product the following steps should be followed:

1. Inspect all shipping boxes for possible shipping damage. If damaged the freight carrier should be contacted immediately and a claim filed.
2. Verify that the model numbers match the purchase order. Contact Force Control if there is a question or problem.

A **CLPC LC** Control System comes in many varieties. Most components are usually supplied by Force Control, but can be supplied by the customer. Also some of the components may be mounted on the **Posidyne Clutch/Brake**. Therefore it is critical that all of the components are carefully checked for receipt. A basic check list follows:

1. **CLPC LC** Control
2. Position Encoder (May be furnished loose, by customer, or mounted on the *Posidyne* Clutch/Brake.)
3. Home Sensor (May be part of the Encoder, furnished loose, by customer, or mounted on the *Posidyne* Clutch/Brake.)
4. Junction Box (*Optional*).
5. Cables (quick disconnect) to actuation valve, incremental encoder, home sensor and brake release valve.

## 3-2 MOUNTING **CLPC LC** Control

(See Figures 3.1, 3.2 and 3.3)

The **CLPC LC** Control is a door mounted or panel mounted (with optional mounting bracket) NEMA 1 enclosure. The **CLPC LC** becomes a NEMA 4 enclosure when door mounted with a gasket. It should be mounted in a location convenient for the operator and where required electrical service is available.

1. Away from excessive heat. (*Operating temperature should be from 32° to 140° F.*)
2. Protected from rain or excessive moisture.
3. Protected from metallic dust, corrosive gases or explosive components.
4. Mounted on a solid structure protected from excessive vibration.
5. Within 1000 Ft. with a differential encoder or 50 Ft. with a single ended open collector output encoder or home switch.
6. See *Figure 3.2* for mounting template and *Figure 3.3* for recommended minimum clearances for the control.

**IMPORTANT: Do not mount the control in a panel that has motor starters or other high voltage devices.**

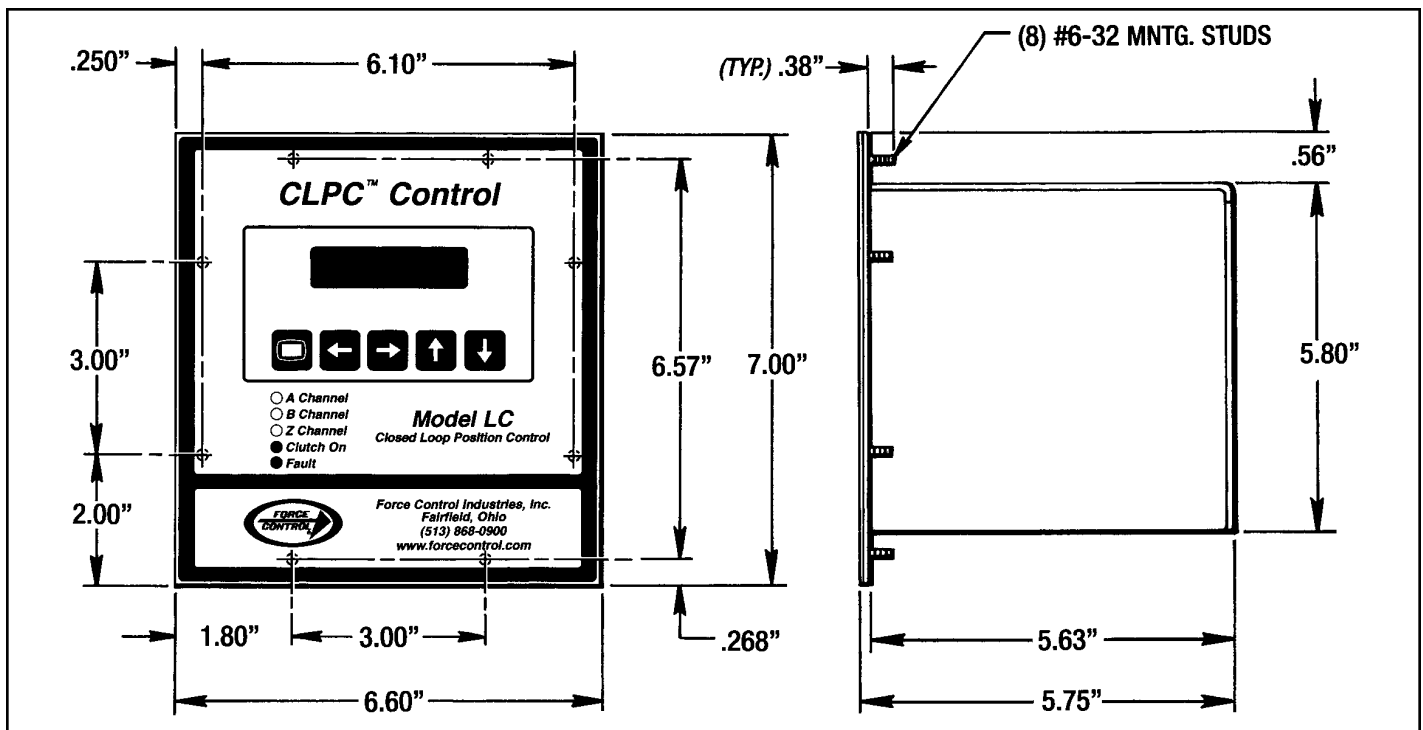

Figure 3.1 - CLPC-LC Control Enclosure Dimensions

**COPY THIS PAGE AND USE IT FOR A MOUNTING  
TEMPLATE ON YOUR PANEL OR DOOR.**

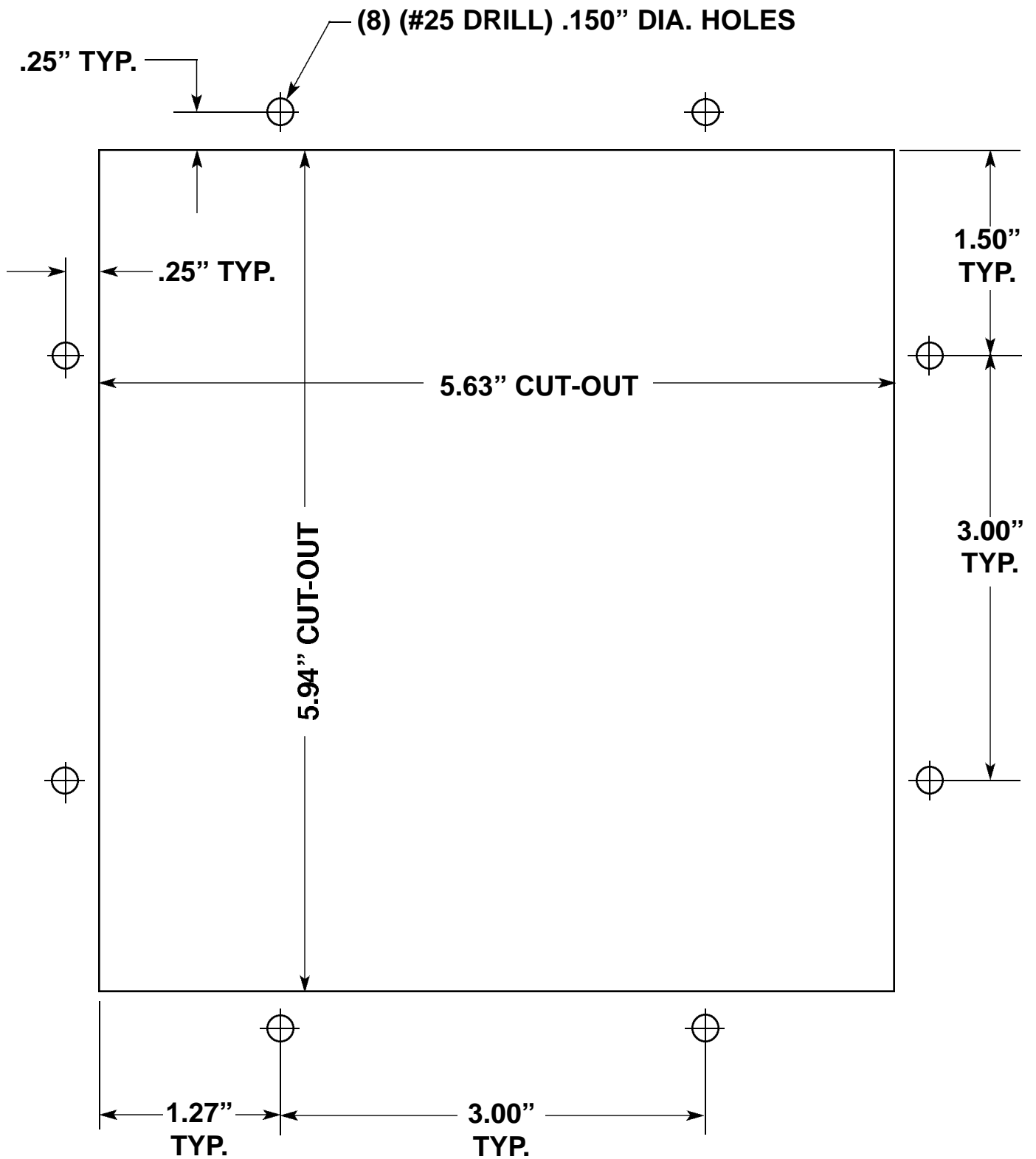

Figure 3.2 - CLPC-LC Mounting Template

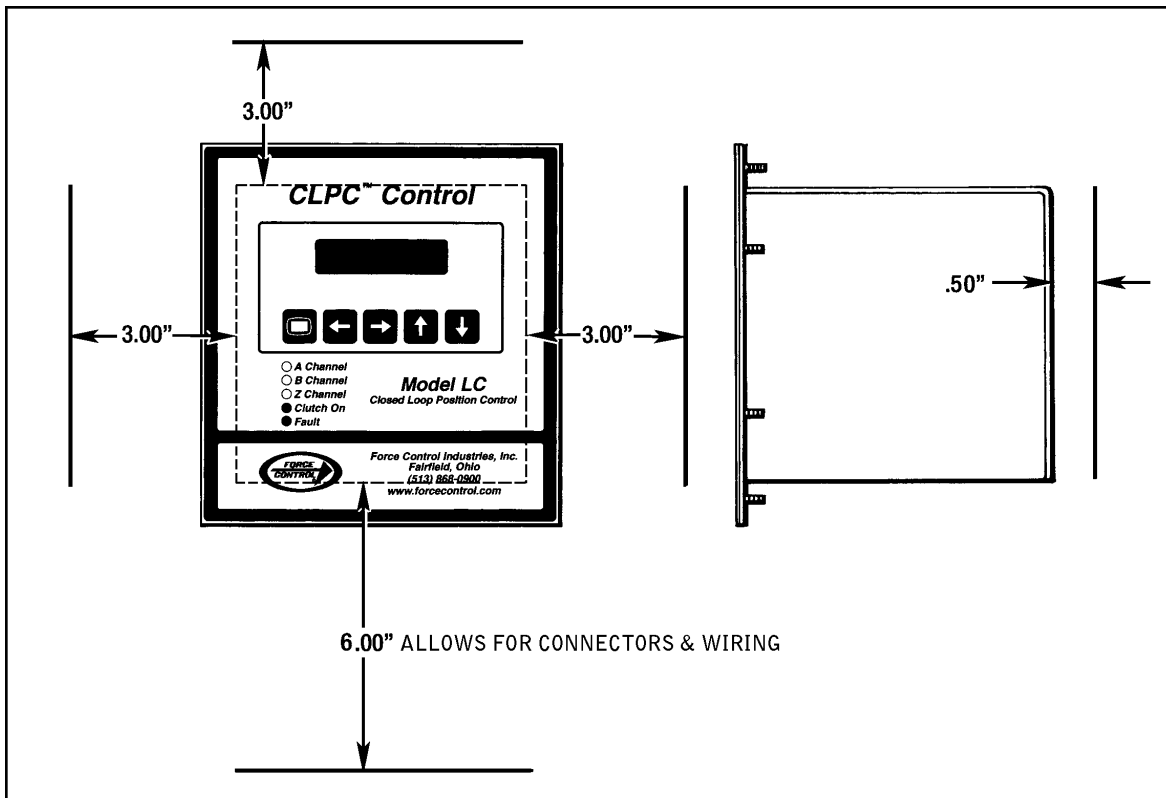

Figure 3.3 - Minimum Mounting Clearances

### 3-3 MOUNTING OPTIONAL JUNCTION BOX

(See Figure 3.4)

The optional Junction Box is used when the distance between the **CLPC LC Control** and the encoder, home switch and actuation valve are located where conduit

should be run, rather than cables, directly from the control. The Junction Box should be located near the **Posidyne Clutch/Brake** and /or external encoders. The Brad-Harrison quick connect cables are used to connect these components to the junction box. Conduit is then run from the Junction Box to the **CLPC LC Control**.

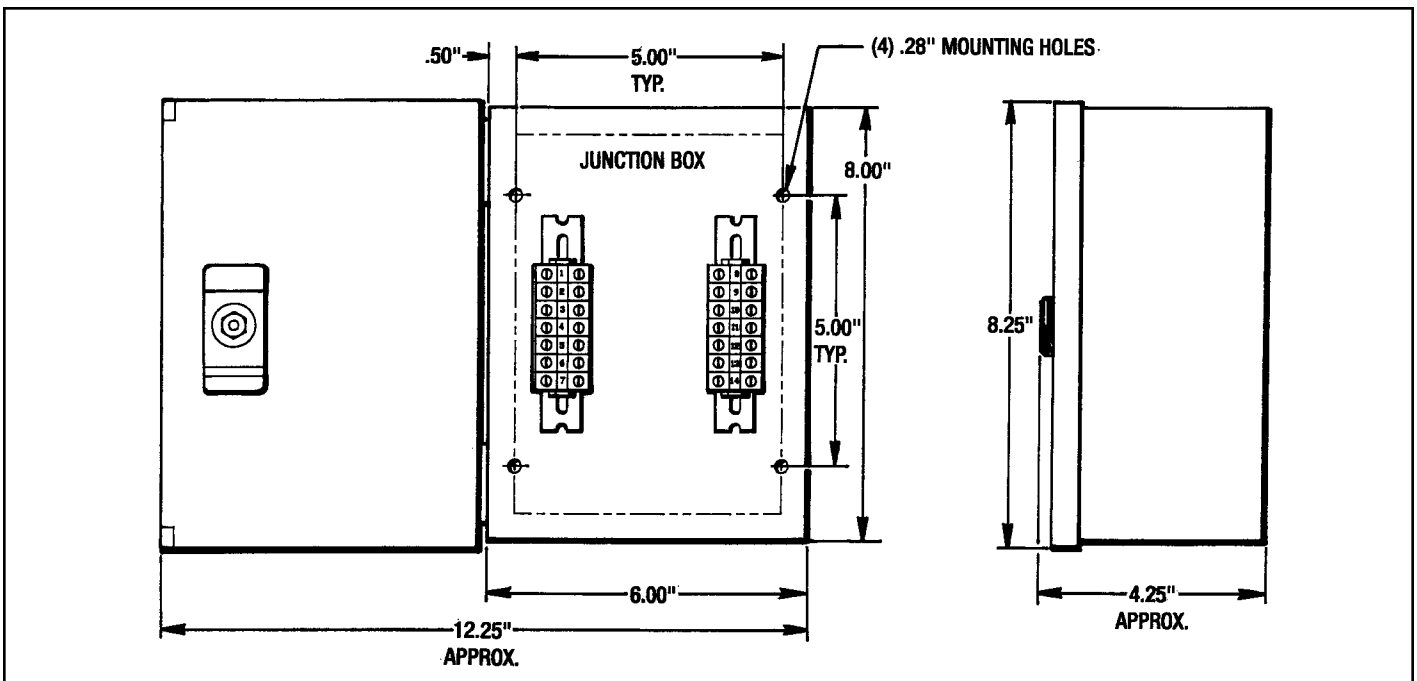

Figure 3.4 - Junction Box Mounting

**FORCE CONTROL INDUSTRIES, INC.**



MEX (55) 53 63 23 31 MTY (81) 83 54 10 18  
 QRO (442) 1 95 72 60 ventas@industrialmagza.com

### 3-4 MOUNTING EXTERNAL ENCODER

If you are using an external Encoder it should be mounted to pick up the proper shaft for correct control operation. Check with Force Control Industries, Inc. if there are any questions.

### 3-5 MOUNTING EXTERNAL HOME SENSOR

The external Home Sensor is used to calibrate the control to the mechanical position of the machine drive and to verify "Home" position for each index or cycle.

It should be located where it will pick up the "Home" position of the machine for each cycle. This can be on the output shaft of a reducer, head shaft of a conveyor, located to detect a product going by, or the crank arm on a harmonic application.

On some cut-to-length applications the Home Sensor may be triggered by the operation of the cut-off device, when the press opens or used to maintain registration on printed material by reading a registration mark.

On many applications the Home Sensor is located in the Encoder Housing on the **Posidyne Clutch/Brake** and is connected by the same cable as the Incremental Encoder.

### 3-6 ELECTRICAL CONNECTIONS

There are numerous wiring connections to be made, some of which will be completed when the system is received and others that will need to be completed in the field. Also note that there may be optional items which will not be used in all applications.

**IMPORTANT: It is critical that the correct wiring type and wiring paths be followed for maximum performance and minimum of electrical noise interruptions.**

Electrical noise is any electrical disturbance which can cause erroneous operation of the control. It is often caused by transients generated by load switching where line to ground spikes are generated. Starting of motors, actuating solenoids and certain types of motors such as regenerative and synchronous motors can all cause transients.

The **CLPC LC** Control has a high degree of noise immunity built in, however electrical noise can cause erratic operation of the **CLPC**. Therefore it is important to follow the following recommended wiring procedures on the next page.

#### A. Type of Wiring for Encoder Connections

The wire for the encoders should be individually shielded,

twisted pair tray cable with minimum 22 AWG copper stranded conductors. Pairs which can be routed together are shown on the wiring diagrams. The wire should be as short as possible. Excess wire should be cut off, not coiled up. **The cable shields should be grounded only at the DC negative of the control.** (See wiring diagram for proper terminals on the **CLPC LC** Control.)

#### B. Wire Paths

**CAUTION: Avoid running high voltage and low voltage lines together.**

All high speed, low voltage cables from encoders, home switch, air valves, etc. must be routed away from high voltage cables, AC power lines or other wiring carrying rapid switching transients. If a long run is necessary the encoder wiring should be run in a dedicated conduit for that purpose only.

#### C. Max. Wire Lengths

The max. wire length for a differential encoder is 1000 Ft. For a single ended open collector encoder or external home switch it is 50 Ft. The control valve can be 1000 Ft. away from the CLPC LC control.

### 3-7 MAIN POWER TO CLPC LC CONTROL

(See Figure 3.5)

Universal power supply input is 85-264 VAC, 47-63 Hz, Single Phase, 100 Watts max. and fused internally at 4 Amps. The power should be clean and of good quality similar to that used for other electronic devices. Should the line power be "dirty" with high voltage spikes and transients a dedicated isolation transformer should be used. It is recommended to use some form of external fuse protection since the internal fuse is inaccessible.

### 3-8 TERMINAL BLOCK J1 (Main Power Supply to CLPC LC Control)

(See Figure 3.5)

85-264 VAC . . . . .to Terminal Block J1 . . . . .Terminal #1  
Neutral . . . . .to Terminal Block J1 . . . . .Terminal #2  
Earth Ground . . . . .to Terminal Block J1 . . . . .Terminal #3

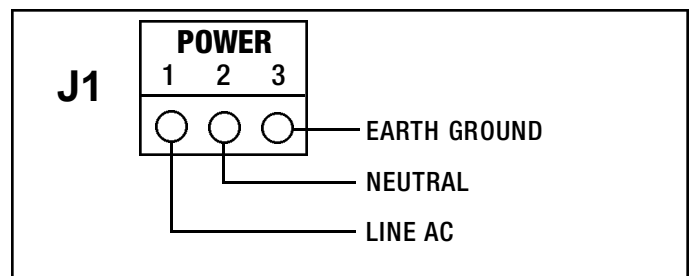
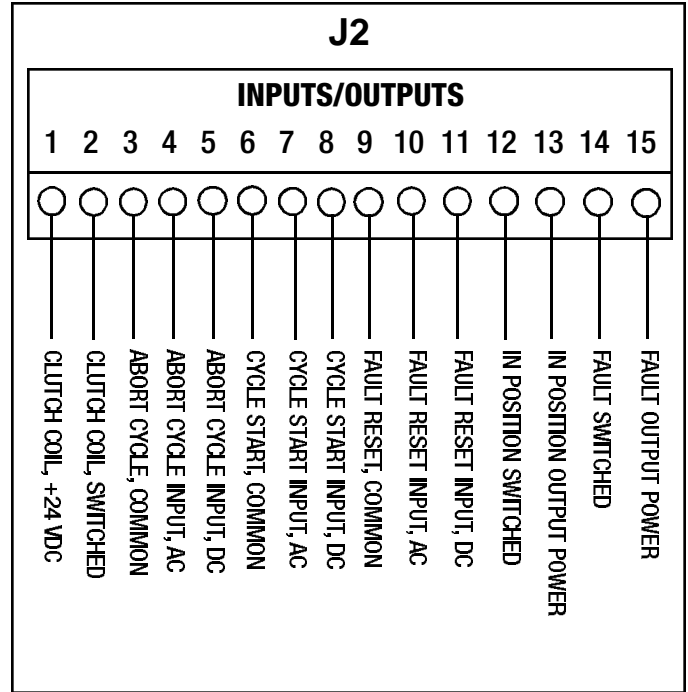

Figure 3.5 - Terminal Block J1

### 3-9 TERMINAL BLOCK J2 (Inputs and Outputs) *(See Figure 3.6)*

#### TERMINAL BLOCK J2

Terminal #1	Clutch Coil, + 24 VDC	Power is on to clutch actuation valve.
Terminal #2	Clutch Coil, Switched	
Terminal #3	Abort Cycle, Common	
Terminal #4	Abort Cycle Input, AC*	Abort active cycle and discontinue further cycles until reset.
Terminal #5	Abort Cycle Input, DC**	
Terminal #6	Start Cycle, Common.	
Terminal #7	Start Cycle Input, AC*	Initiates an index.
Terminal #8	Start Cycle Input, DC**	
Terminal #9	Fault Reset, Common	
Terminal #10	Fault Reset Input, AC*	Resets faults remotely.
Terminal #11	Fault Reset Input, DC**	
Terminal #12	In Position Switched	Indicates that drive stopped within position window.
Terminal #13	In Position Output Power	
Terminal #14	Fault Switched	Indicates a fault has occurred in the CLPC.
Terminal #15	Fault Output Power	



**NOTES:** \* 90-140 VAC ; \*\* 24 VDC

Figure 3.6 - Terminal Block J2

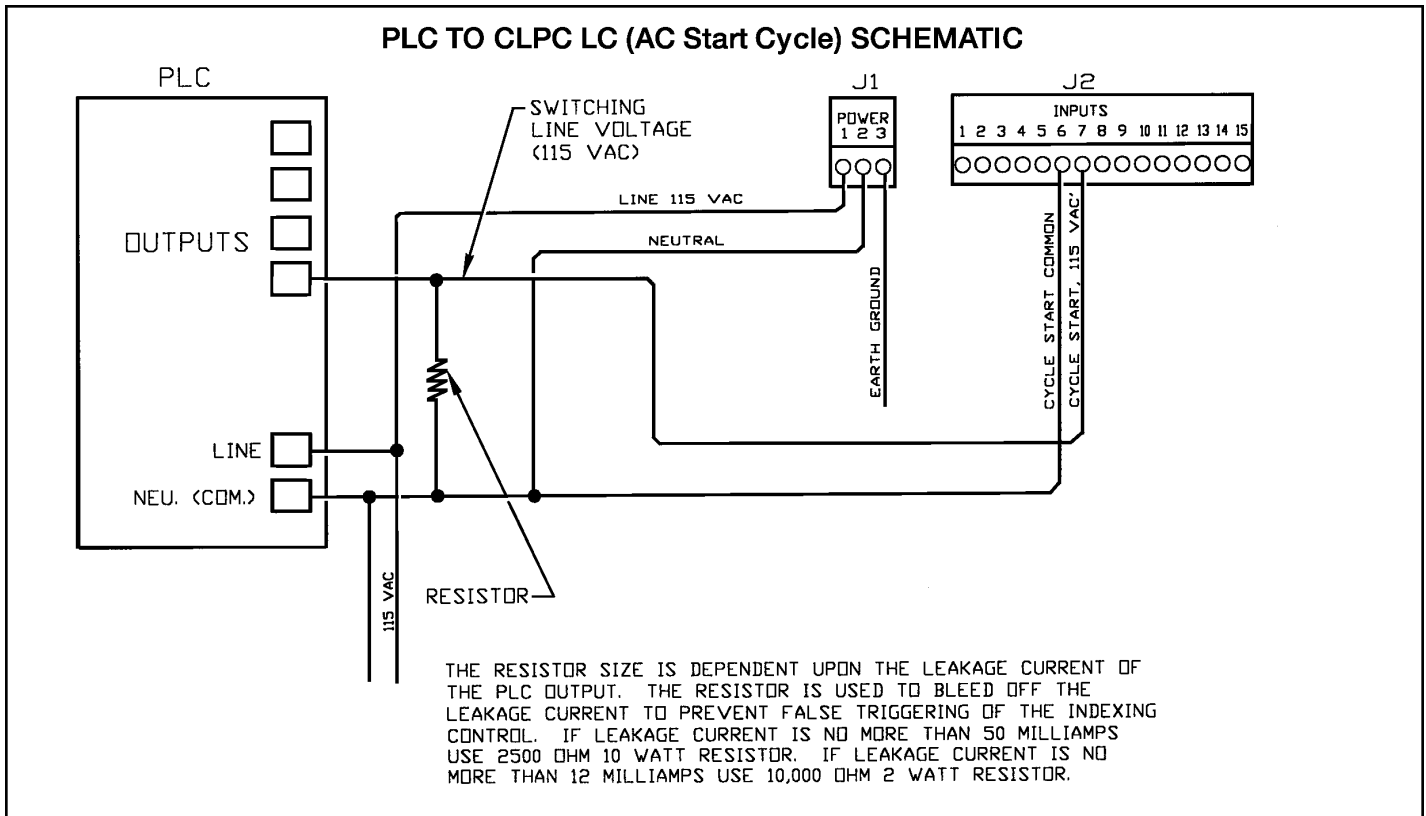

Figure 3.7- PLC to CLPC LC (AC Start Cycle) Schematic

## PLC TO CLPC LC (DC START CYCLE) SCHEMATIC

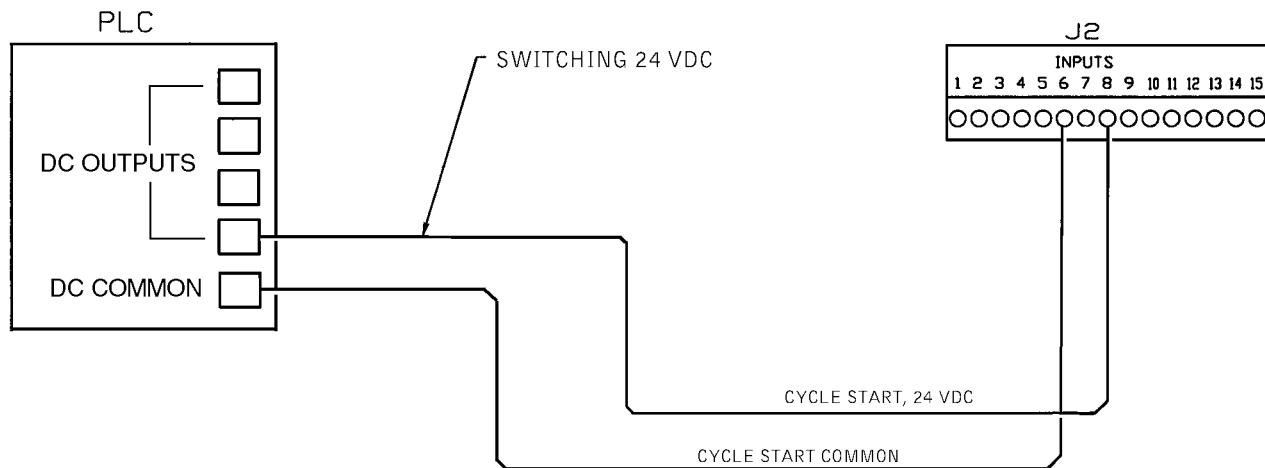

Figure 3.8 - PLC to CLPC LC (DC Start Cycle) Schematic

## 115 VAC CYCLE START/HAND OFF AUTO/SINGLE INDEX

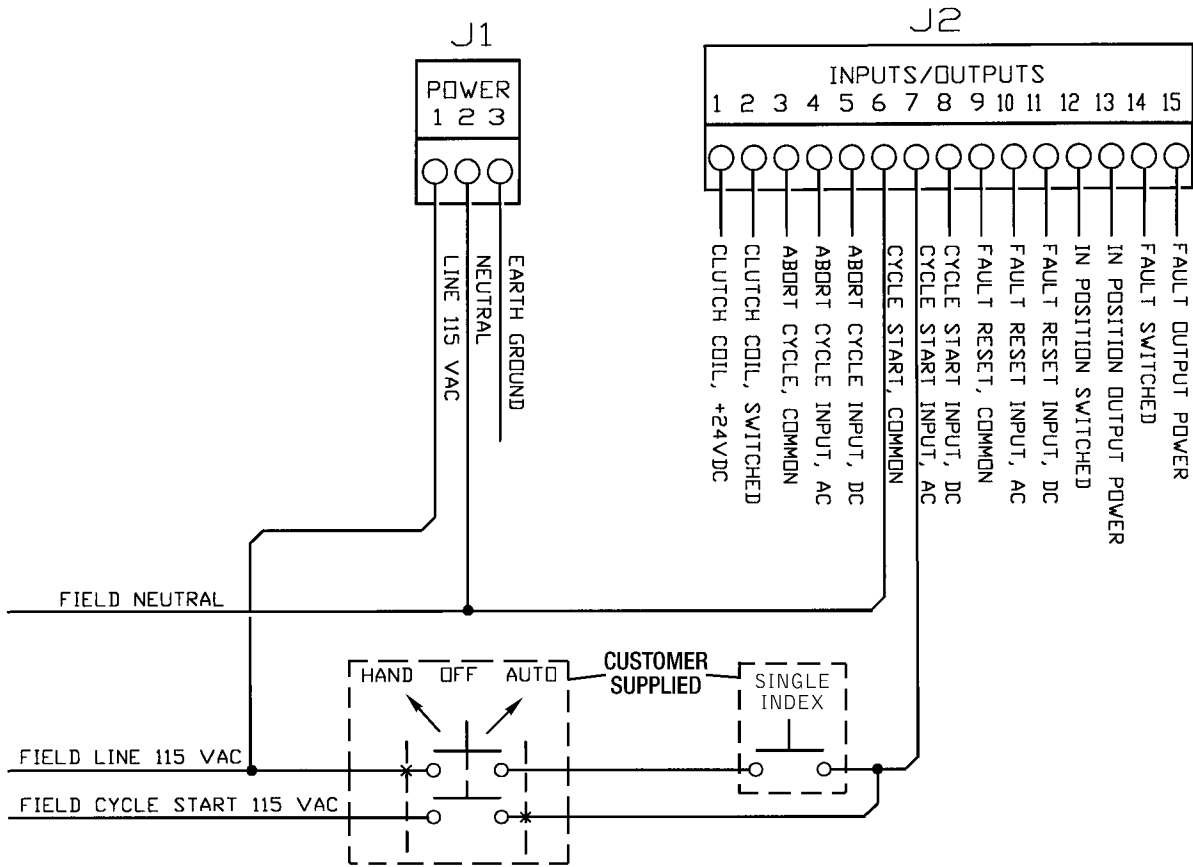

Figure 3.9 - Cycle Start/Hand Off Auto/Single Index (115 VAC)

## CYCLE START/HAND OFF AUTO/SINGLE INDEX (Customer Supplied 24 VDC)

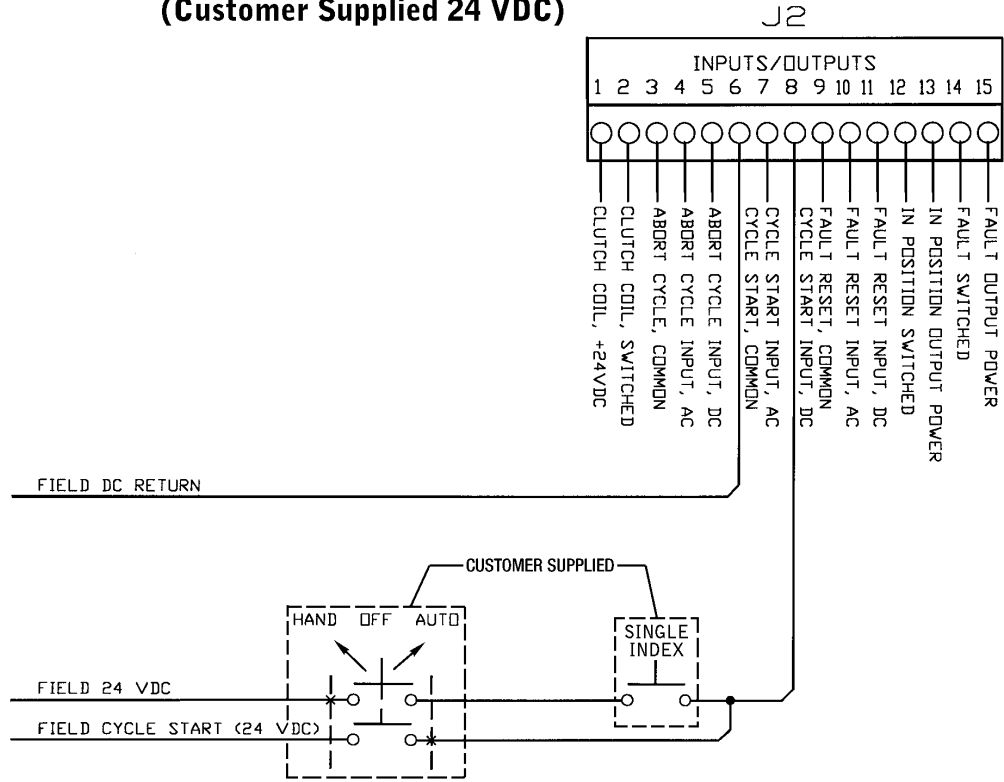
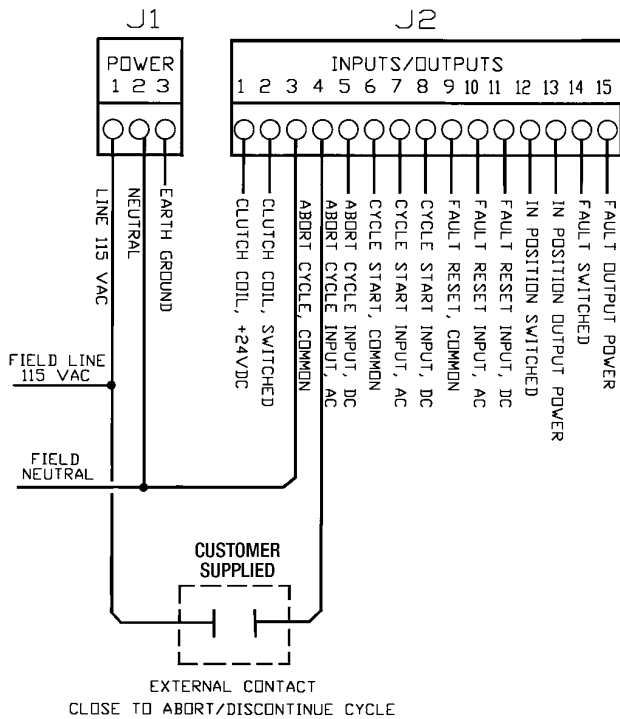

Figure 3.10 - Cycle Start/Hand Off Auto/Single Index (Customer Supplied 24

### 115 VAC ABORT CYCLE



### 24 VDC ABORT CYCLE (CUSTOMER SUPPLIED)

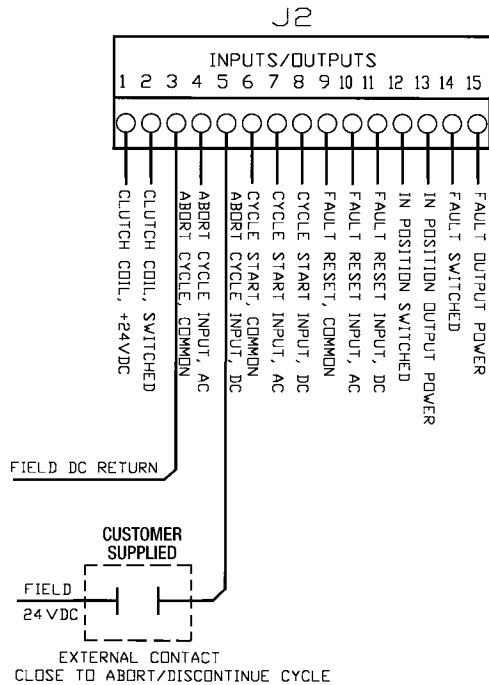

Figure 3.11 - Abort Cycle

### 3-10 TERMINAL BLOCK J3

#### A. CLPC LC Control to Optical Encoder with Internal Home Sensor (See Figure 3.12)

##### TERMINAL BLOCK J3

Terminal #1	Program Lock Input Power
Terminal #2	Program Lock Return
Terminal #3	Power, +12 VDC
Terminal #4	VDC Ground
Terminal #5	Power, +12 VDC
Terminal #6	VDC Ground
Terminal #7	B' (Compliment) - Channel
Terminal #8	B - Channel
Terminal #9	A' (Compliment) - Channel
Terminal #10	A - Channel
Terminal #11	Z' (Compliment) - Home Channel
Terminal #12	Z - Home Channel

#### NOTES:

1. The Internal Home Sensor uses the same power as the Optical Encoder.
2. Encoder wiring shown is for C.W. rotation of *Posidyne* output shaft. If C.C.W. rotation is desired reverse "A" and "B" encoder signals or change the Encoder Sense setting through the menu interface.
3. Encoder Channel "A" must lead Channel "B". Slowly rotate the *Posidyne* output shaft in a the proper direction and check to be sure the Position Display counts up. If they don't, change the Encoder Sense setting through the menu interface.

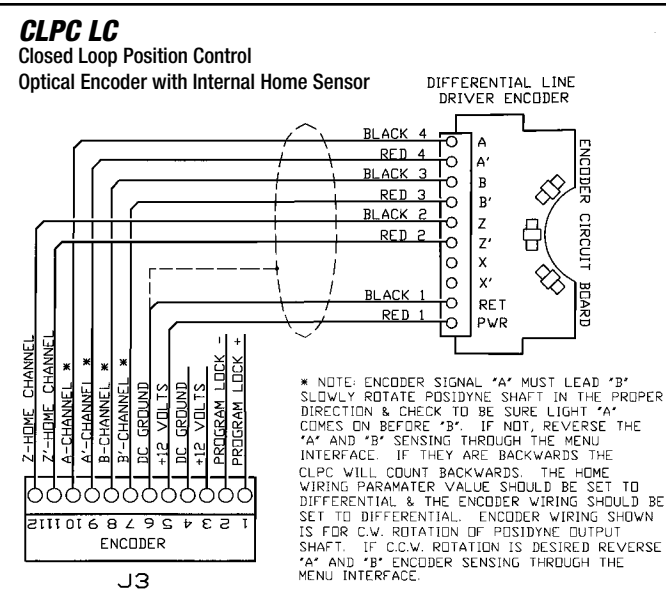

Figure 3.12 - Wiring Diagram - Terminal Block #J3 (With Internal Home Sensor)

#### B. CLPC LC Control to Optical Encoder with External Home Sensor (See Figure 3.13)

##### TERMINAL BLOCK J3

Terminal #1	Program Lock Input Power
Terminal #2	Program Lock Return
Terminal #3	Power, +12 VDC
Terminal #4	VDC Ground
Terminal #5	Power, +12 VDC
Terminal #6	VDC Ground
Terminal #7	B' (Compliment) - Channel
Terminal #8	B - Channel
Terminal #9	A' (Compliment) - Channel
Terminal #10	A - Channel
Terminal #11	Z' (Compliment) - Home Channel
Terminal #12	Z - Home Channel

#### NOTES:

1. Encoder wiring shown is for C.W. rotation of *Posidyne* output shaft. If C.C.W. rotation is desired reverse "A" and "B" encoder signals or change the Encoder Sense setting through the menu interface.
2. Encoder Channel "A" must lead Channel "B". Slowly rotate the *Posidyne* output shaft in a the proper direction and check to be sure the Position Display counts up. If they don't, change the Encoder Sense setting through the menu interface.

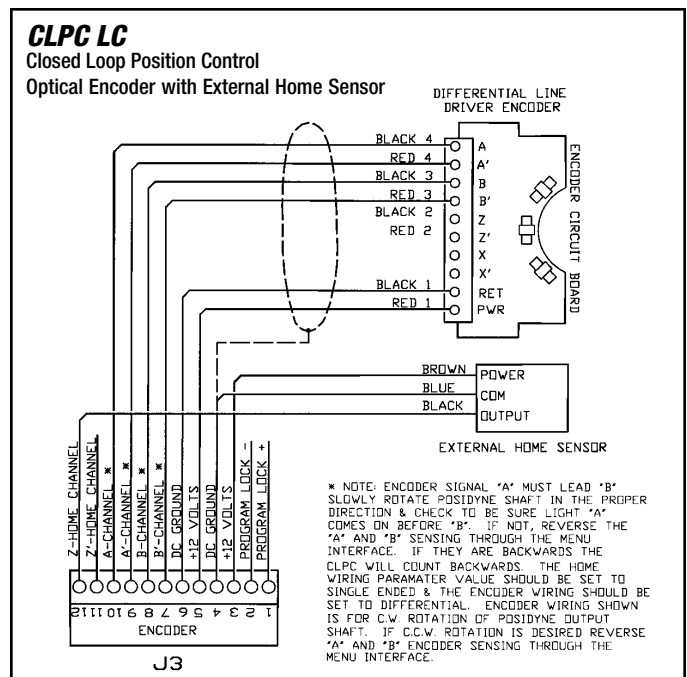

Figure 3.13 - Wiring Diagram - Terminal Block #J3 (With External Home Sensor)

**C. CLPC LC Control to Optical Encoder with External Photo Sensor** (See Figure 3.14)

**TERMINAL BLOCK J3**

Terminal #1	Program Lock Input Power
Terminal #2	Program Lock Return
Terminal #3	Power, +12 VDC
Terminal #4	VDC Ground
Terminal #5	Power, +12 VDC
Terminal #6	VDC Ground
Terminal #7	B' (Compliment) - Channel
Terminal #8	B - Channel
Terminal #9	A' (Compliment) - Channel
Terminal #10	A - Channel
Terminal #11	Z' (Compliment) - Home Channel
Terminal #12	Z - Home Channel

**NOTES:**

- Encoder wiring shown is for C.W. rotation of Posidyne output shaft. If C.C.W. rotation is desired reverse "A" and "B" encoder signals or change the Encoder Sense setting through the menu interface.
- Encoder Channel "A" must lead Channel "B". Slowly rotate the Posidyne output shaft in a the proper direction and check to be sure the Position Display counts up. If they don't, change the Encoder Sense setting through the menu interface.

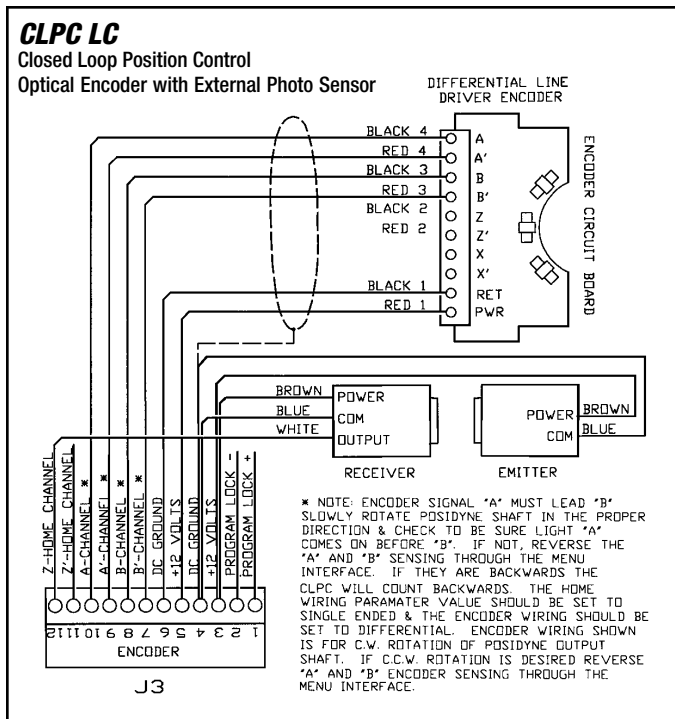

Figure 3.14 - Wiring Diagram - Terminal Block #J3 (With External Photo Sensor)

**D. Program Lock**

The **Program Lock**, when connected, disables the ability to enter the Program Mode with the front panel push button. This can be used to prevent any changes to the parameter settings after the control is configured.

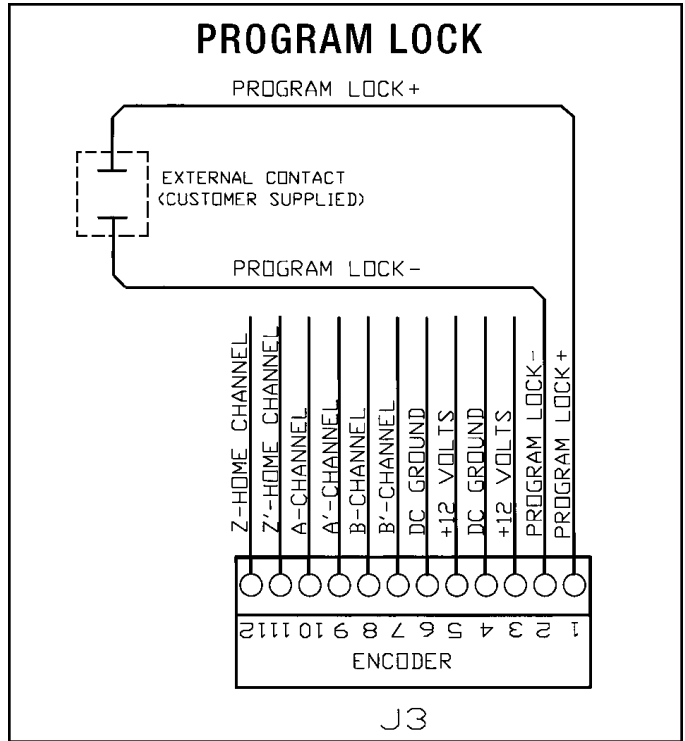

Figure 3.15 - Program Lock

**3-11 TERMINAL BLOCK J4 (Optional PLS Outputs and MIP Inputs)** (See Figure 3.16)

The MIP/PLS Expansion Board offers two options to the standard CLPC LC Control.

**A. Capabilities**

- Programmable Limit Switch Outputs** - Sends an output when the limit switch "PLS n ON" is reached and stays on until the "PLS n OFF" is reached. Up to (4) separate Limit Switches can be programmed anywhere from the first to the last count. These outputs can be used to start up to 4 additional machine functions during the index.
- Multiple Indexing Parameters (MIP)** - are inputs from a PLC or other source which allows the CLPC LC Control to select one of (16) different **Indexing Parameter Groups**. Each parameter group includes maximum count (index distance), manual adjust, in position range and the associated trigger. By turning the proper inputs on, a specific program can be selected and used by the control when the cycle start signal is received.

**Inputs** - Solid state relays are used (115 VAC are standard), 7 to 60 VDC relays are available, 10 mAmax. input current, 2.5 mA drop out current, 3.0 mA allowable for output.

**NOTE:** For AC inputs that are driven by a device that has leakage current (PLC) a resistor may be required across the terminals to bleed off current to avoid false triggering. The resistor size is dependent upon the leakage current of the PLC output. If the leakage current is no more than 50 mA use a 2500 ohm, 10 watt resistor. If less than 12 mA use a 10,000 ohm, 2 watt resistor. (See Figure 3.7)

**TERMINAL BLOCK J4**

Terminal #1	MIP 1 Input Power
Terminal #2	MIP 1 Return
Terminal #3	MIP 2 Input Power
Terminal #4	MIP 2 Return
Terminal #5	MIP 3 Input Power
Terminal #6	MIP 3 Return
Terminal #7	MIP 4 Input Power
Terminal #8	MIP 4 Return
Terminal #9	PLS 1 Output Power
Terminal #10	PLS 1 Switched
Terminal #11	PLS 2 Output Power
Terminal #12	PLS 2 Switched
Terminal #13	PLS 3 Output Power
Terminal #14	PLS 3 Switched
Terminal #15	PLS 4 Output Power
Terminal #16	PLS 4 Switched

MIP = Multiple Indexing Parameter  
PLS = Programmable Limit Switch

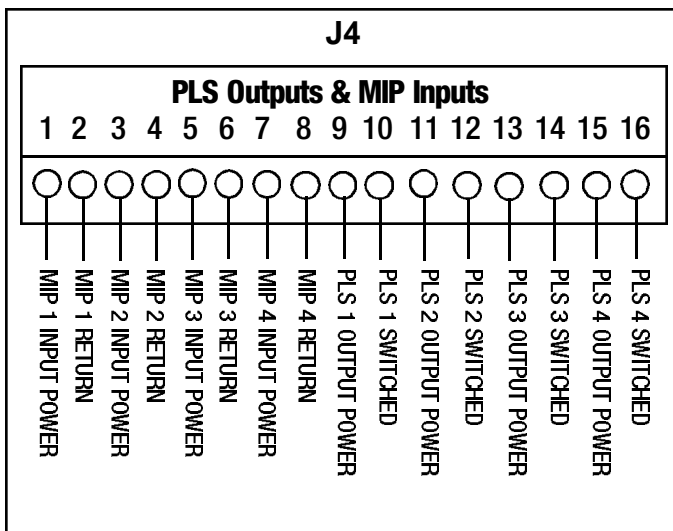

Figure 3.16 - Terminal Block #J4

**B. Programming**

See Section 4-4, A. General Procedure for Setting Parameters.

**MENU PARAMETERS #16 to #23 - PLS Outputs**

Each PLS Output can be programmed to be off, or any window within the range of 0 to (Max Count -1). Set the **PLS n ON** Parameter to the "Turn On" position of the encoder and set the **PLS n OFF** to the encoder "Turn Off" position.

**Example** - If a 100 count window for PLS #1 is desired starting at encoder position 10, program **PLS 1 ON** to be 10 and **PLS 1 OFF** to be 110.

**MENU PARAMETERS #24 to #71 - MIP Inputs**

Using the **(MIP) Group Work Sheet**, shown on the next page, program each **MIP Input** with the desired Max. Count, Manual Adjust and MIP Window. Once programmed, select the required MIP Group via the Input Relays as shown in the following table.

**Multiple Indexing Parameter (MIP) Relay Logic Table**

(MIP) GROUP	(MIP) GROUP SELECT			
	MIP4	MIP3	MIP2	MIP1
0	0	0	0	0
1	0	0	0	1
2	0	0	1	0
3	0	0	1	1
4	0	1	0	0
5	0	1	0	1
6	0	1	1	0
7	0	1	1	1
8	1	0	0	0
9	1	0	0	1
A	1	0	1	0
B	1	0	1	1
C	1	1	0	0
D	1	1	0	1
E	1	1	1	0
F	1	1	1	1

0 = OFF    1 = ON

### 3-12 (MIP) GROUP WORKSHEET

PARAMETER	(MIP) GROUP							
	0	1	2	3	4	5	6	7
A. Max Count (MC)								
B. Trigger Point* (TP)								
C. Manual Adjust (MA)								
D. In Position window								

PARAMETER	(MIP) GROUP							
	8	9	A	B	C	D	E	F
A. Max Count (MC)								
B. Trigger Point* (TP)								
C. Manual Adjust (MA)								
D. In Position window								

\* System data storage location (Trigger Point) is not user adjustable, but is system calculated and stored for each System Parameter Group.

#### NOTES:

---



---



---



---



---



---



---



---



---



---

### 3-13 CLPC LC CONTROL TO JUNCTION BOX

JUNCTION BOX TERMINAL	FUNCTION	CONNECT TO CLPC LC TERMINAL	JUNCTION BOX TERMINAL	FUNCTION	CONNECT TO CLPC LC TERMINAL
1	Clutch Coil, +24 VDC	J2,#1	9	Encoder Channel Z	J3,#12
2	Clutch Coil, Switched	J2,#2	10	Encoder Channel A' (Comp.)	J3,#9
3	Not Used	----	11	Encoder Channel A	J3,#10
4	Not Used	----	12	Encoder Channel B' (Comp.)	J3,#7
5	Not Used	----	13	Encoder Channel B	J3,#8
6	Not Used	----	14	Encoder & Home Sensor DC Grd.	J3,#6
7	E Ground	----	15	Encoder & Home Sensor Pwr.,12 VDC	J3,#5
8	Encoder Channel Z' (Home) (Comp.)	J3,#11	----	Encoder Cable Shields*	J2,#6

**\* IMPORTANT - Take care to keep all Cable Shield Wires isolated from any conductive surface to prevent a ground loop between the control and the junction box.**

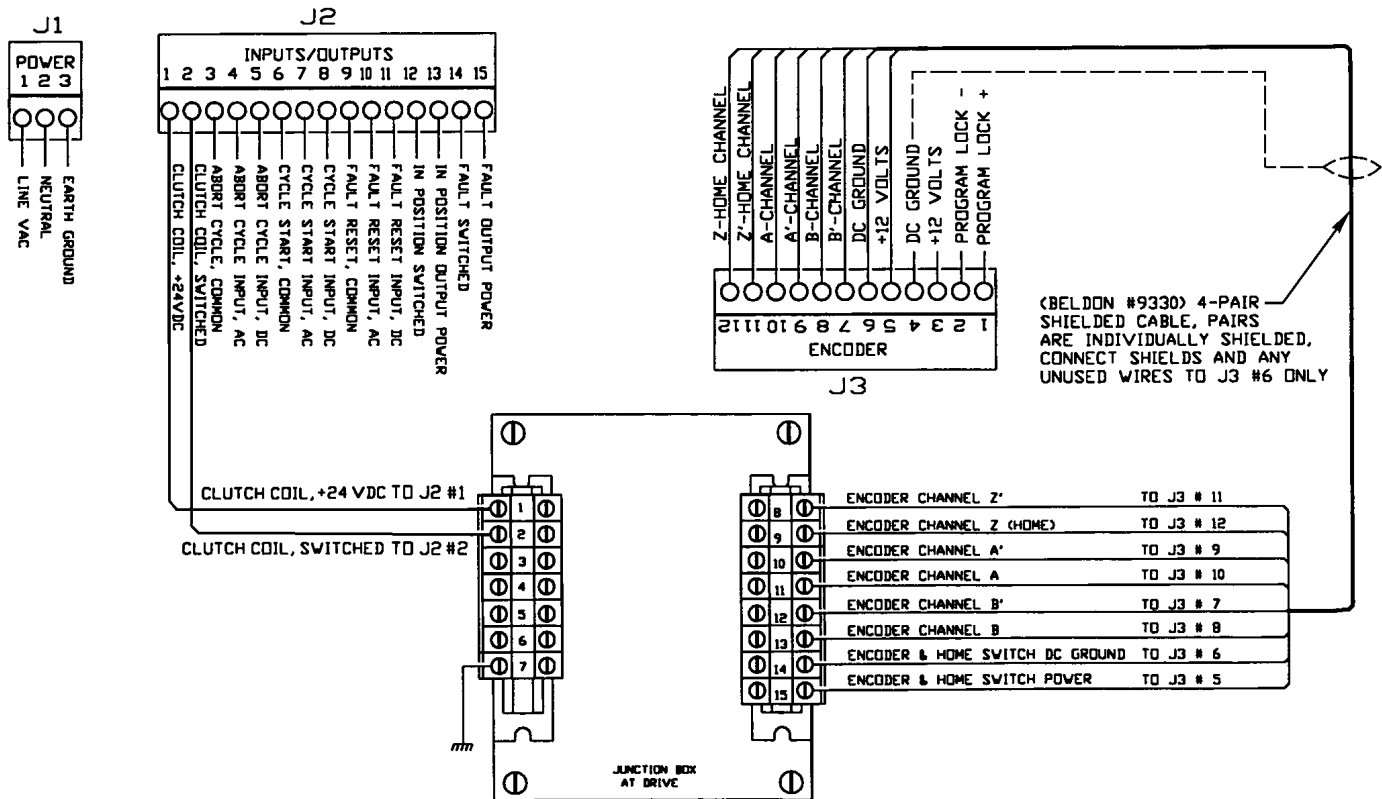

Figure 3.17 - Wiring Diagram - CLPC LC Control to Junction Box

### 3-14 JUNCTION BOX TO ACTUATION VALVES AND OPTICAL ENCODER

#### A. With Internal Home Sensor (Channel Z)

JUNCTION BOX TERMINAL	FUNCTION	WIRE COLOR	CONNECT TO TERMINAL	JUNCTION BOX TERMINAL	FUNCTION	WIRE COLOR	CONNECT TO TERMINAL
<b>Size 01 to 10 Posidyne Clutch/Brake</b>				<b>All Sizes Posidyne Clutch/Brakes</b>			
1	Clutch Coil, +24 VDC	White	2	7	E Ground	Green	4
2	Clutch Coil, Switched	Black	1	8	Encoder Z' Channel	Red 2	Z'
<b>Size 11 to 20 Posidyne Clutch/Brake</b>				<b>All Sizes Posidyne Clutch/Brakes</b>			
1	Clutch Coil, +24 VDC	Red	2	9	Encoder Z Channel	Black 2	Z
2	Clutch Coil, Switched	Black	1	10	Encoder A' Channel	Red 4	A'
<b>All Sizes Posidyne Clutch/Brakes</b>				<b>All Sizes Posidyne Clutch/Brakes</b>			
3	Not Used	----	----	11	Encoder A Channel	Black 4	A
4	Not Used	----	----	12	Encoder B' Channel	Red 3	B'
5	Not Used	----	----	13	Encoder B Channel	Black 3	B
6	Not Used	----	----	14	DC Ground	Black 1	Ret.
				15	Encoder Power, +12 VDC	Red 1	Pwr.
					Encoder Cable Shields*	----	----

\* NOTE: ENCODER SIGNAL "A" MUST LEAD "B" SLOWLY ROTATE POSIDYNE SHAFT IN THE PROPER DIRECTION & CHECK TO BE SURE LIGHT "A" COMES ON BEFORE "B". IF NOT, REVERSE THE "A" AND "B" SENSING THROUGH THE MENU INTERFACE. IF THEY ARE BACKWARDS THE CLPC WILL COUNT BACKWARDS. THE HOME WIRING PARAMATER VALUE SHOULD BE SET TO DIFFERENTIAL & THE ENCODER WIRING SHOULD BE SET TO DIFFERENTIAL. ENCODER WIRING SHOWN IS FOR C.W. ROTATION OF POSIDYNE OUTPUT SHAFT. IF C.C.W. ROTATION IS DESIRED REVERSE "A" AND "B" ENCODER SENSING THROUGH THE MENU INTERFACE.

\* IMPORTANT - Take care to keep all Cable Shield Wires isolated from any conductive surface to prevent a ground loop between the control and the junction box.

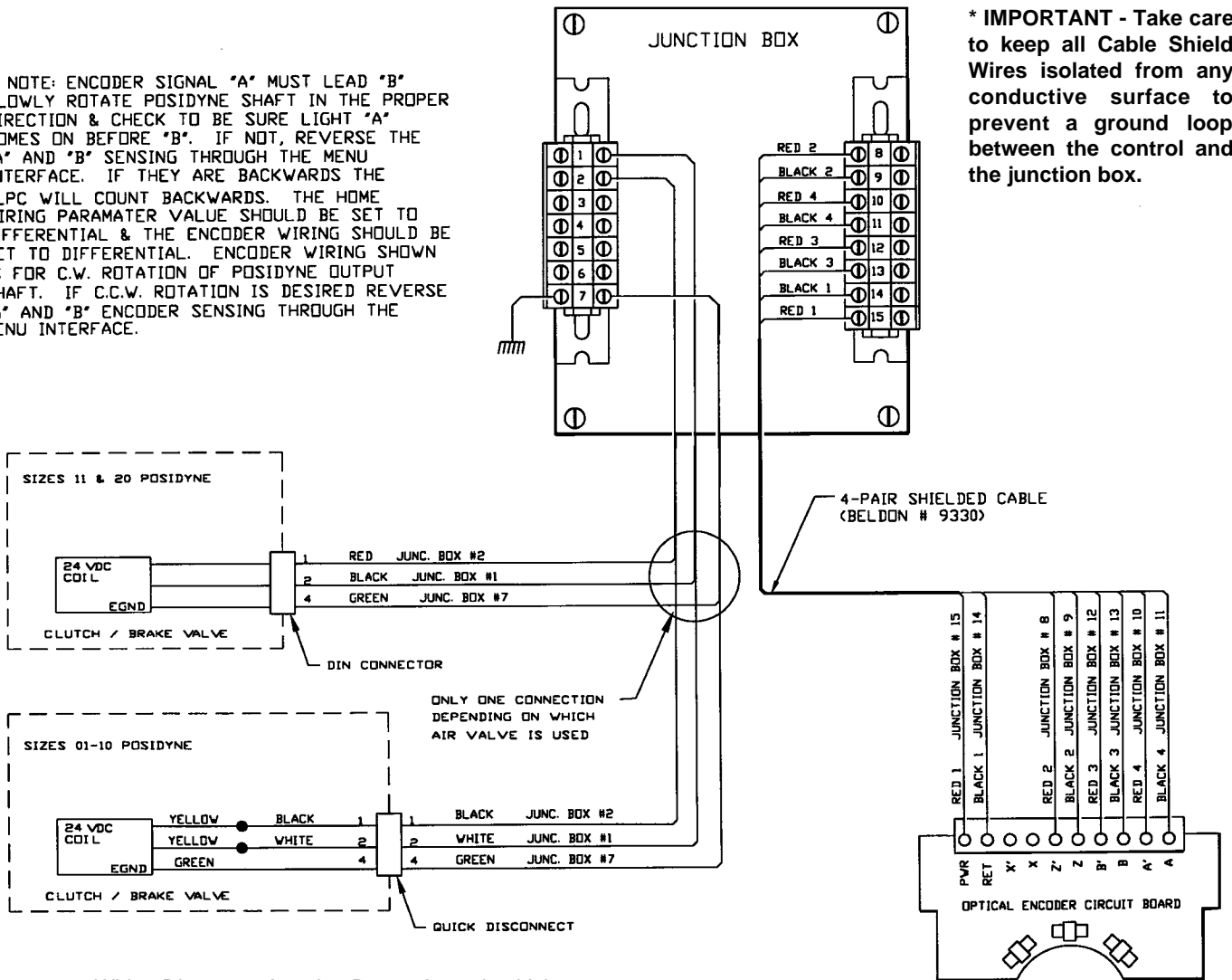

Figure 3.18 - Wiring Diagram - Junction Box to Actuation Valves and Optical Encoder (With Internal Z Channel (Home Sensor))

## B. With External Home Sensor (Channel Z)

JUNCTION BOX TERMINAL	FUNCTION	WIRE COLOR	CONNECT TO TERMINAL	JUNCTION BOX TERMINAL	FUNCTION	WIRE COLOR	CONNECT TO TERMINAL
<b>Size 01 to 10 Posidyne Clutch/Brake</b>				<b>All Sizes Posidyne Clutch/Brakes</b>			
1	Clutch Coil, +24 VDC	White	2	8	Not Used	----	----
2	Clutch Coil, Switched	Black	1	9	External Z Channel (Home)	Black	3
<b>Size 11 to 20 Posidyne Clutch/Brake</b>				10	Encoder A' Channel	Red 4	A'
1	Clutch Coil, +24 VDC	Red	2	11	Encoder A Channel	Black 4	A
2	Clutch Coil, Switched	Black	1	12	Encoder B' Channel	Red 3	B'
<b>All Sizes Posidyne Clutch/Brakes</b>				13	Encoder B Channel	Black 3	B
3	Not Used	----	----	14	Encoder DC Ground	Black 1	Ret.
4	Not Used	----	----	14	External Home Sensor DC Ground	Blue	2
5	Not Used	----	----	15	Encoder Power, +12 VDC	Red 1	Pwr.
6	Not Used	----	----	15	External Home Sensor, +12 VDC	Brown	1
7	E Ground	Green	4	----	Encoder Cable Shields*	----	----

\* NOTE: ENCODER SIGNAL "A" MUST LEAD "B" SLOWLY ROTATE POSIDYNE SHAFT IN THE PROPER DIRECTION & CHECK TO BE SURE LIGHT "A" COMES ON BEFORE "B". IF NOT, REVERSE THE "A" AND "B" SENSING THROUGH THE MENU INTERFACE. IF THEY ARE BACKWARDS THE CLPC WILL COUNT BACKWARDS. THE HOME WIRING PARAMATER VALUE SHOULD BE SET TO SINGLE ENDED & THE ENCODER WIRING SHOULD BE SET TO DIFFERENTIAL. ENCODER WIRING SHOWN IS FOR C.W. ROTATION OF POSIDYNE OUTPUT SHAFT. IF C.C.W. ROTATION IS DESIRED REVERSE "A" AND "B" ENCODER SENSING THROUGH THE MENU INTERFACE.

\* IMPORTANT - Take care to keep all Cable Shield Wires isolated from any conductive surface to prevent a ground loop between the control and the junction box.

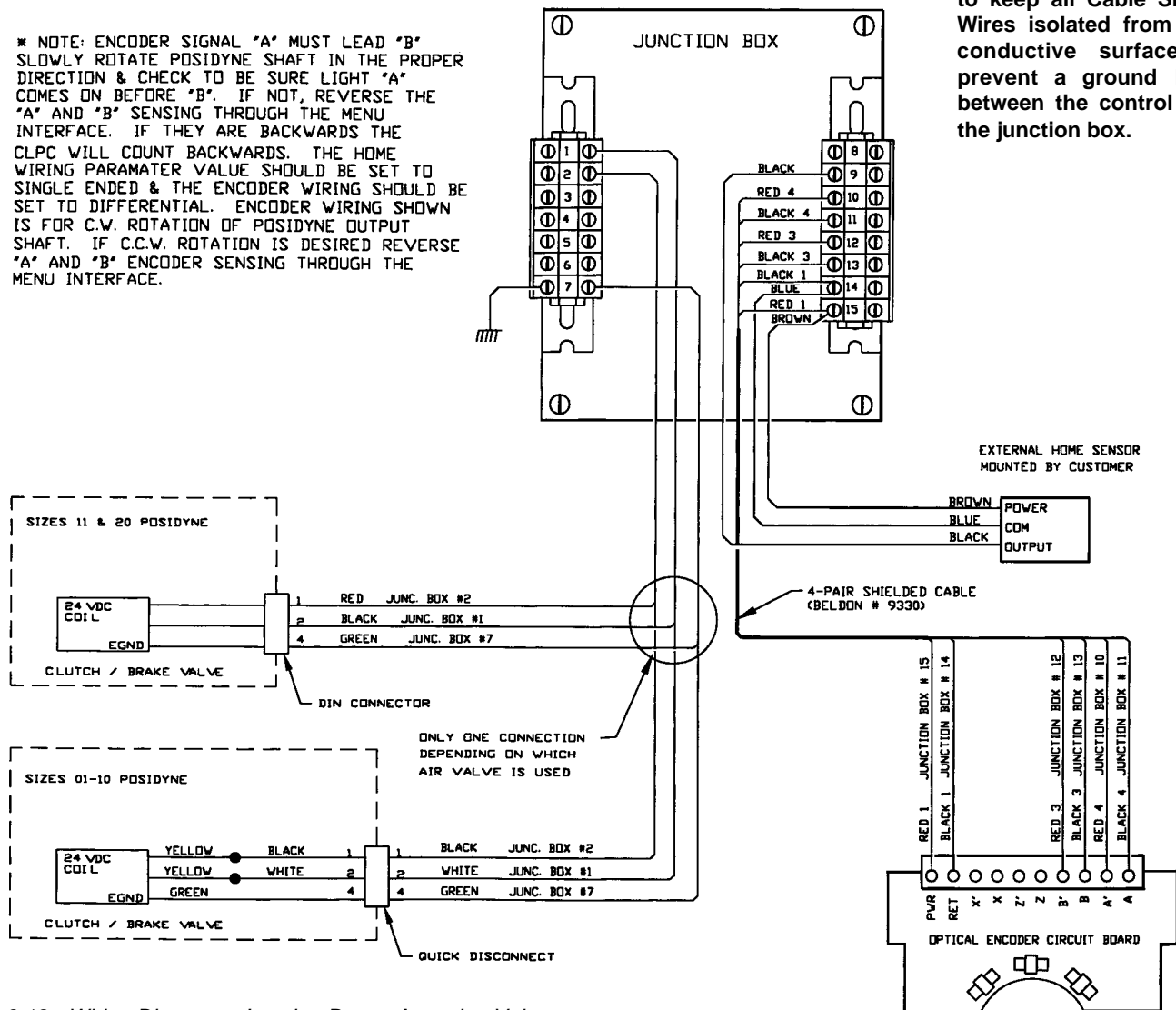

Figure 3.19 - Wiring Diagram - Junction Box to Actuation Valves and Optical Encoder (With External Z Channel (Home Sensor))

### C. With External Photo Home Sensor (Channel Z)

JUNCTION BOX TERMINAL	FUNCTION	WIRE COLOR	CONNECT TO TERMINAL	JUNCTION BOX TERMINAL	FUNCTION	WIRE COLOR	CONNECT TO TERMINAL
<b>Size 01 to 10 Posidyne Clutch/Brake</b>				<b>All Sizes Posidyne Clutch/Brakes</b>			
1	Clutch Coil, +24 VDC	White	2	8	Not Used	----	----
2	Clutch Coil, Switched	Black	1	9	External Z Channel (Home)	Black	3
<b>Size 11 to 20 Posidyne Clutch/Brake</b>				10	Encoder A' Channel	Red 4	A'
1	Clutch Coil, +24 VDC	Red	2	11	Encoder A Channel	Black 4	A
2	Clutch Coil, Switched	Black	1	12	Encoder B' Channel	Red 3	B'
<b>All Sizes Posidyne Clutch/Brakes</b>				13	Encoder B Channel	Black 3	B
3	Not Used	----	----	14	Encoder DC Ground	Black 1	Ret.
4	Not Used	----	----	14	Photo Sensor Emitter DC Gnd.	Blue	2
5	Not Used	----	----	14	Photo Sensor Receiver DC Gnd.	Blue	2
6	Not Used	----	----	15	Encoder Power, +12 VDC	Red 1	Pwr.
7	E Ground	Green	4	15	Photo Sensor Emitter, +12 VDC	Brown	1
----	Encoder Cable Shields*	----	----	15	Photo Sensor Receiver, +12 VDC	Brown	1

\* NOTE: ENCODER SIGNAL "A" MUST LEAD "B" SLOWLY ROTATE POSIDYNE SHAFT IN THE PROPER DIRECTION & CHECK TO BE SURE LIGHT "A" COMES ON BEFORE "B". IF NOT, REVERSE THE "A" AND "B" SENSING THROUGH THE MENU INTERFACE. IF THEY ARE BACKWARDS THE CLPC WILL COUNT BACKWARDS. THE HOME WIRING PARAMETER VALUE SHOULD BE SET TO SINGLE ENDED & THE ENCODER WIRING SHOULD BE SET TO DIFFERENTIAL. ENCODER WIRING SHOWN IS FOR C.W. ROTATION OF POSIDYNE OUTPUT SHAFT. IF C.C.W. ROTATION IS DESIRED REVERSE "A" AND "B" ENCODER SENSING THROUGH THE MENU INTERFACE.

\* IMPORTANT - Take care to keep all Cable Shield Wires isolated from any conductive surface to prevent a ground loop between the control and the junction box.

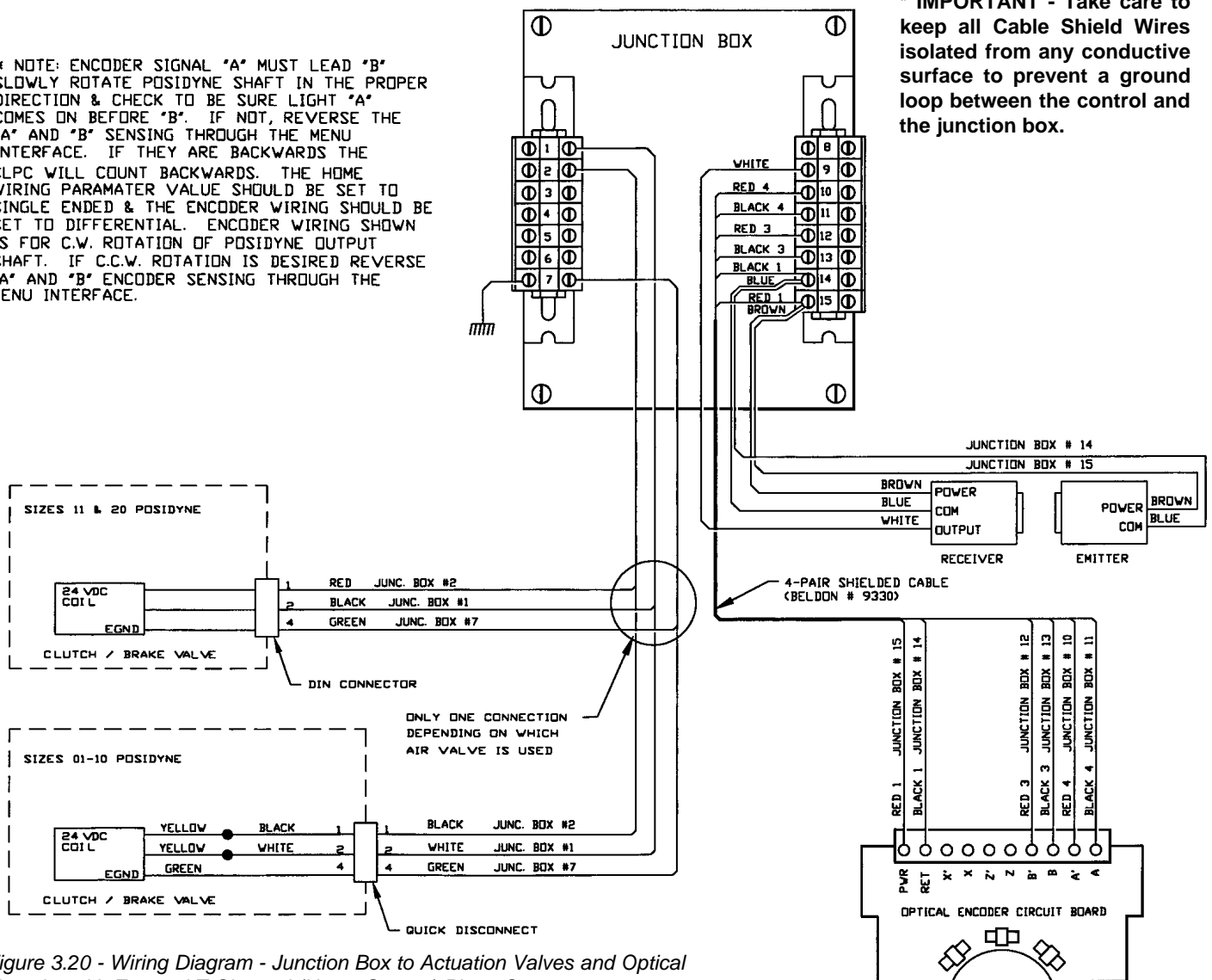

Figure 3.20 - Wiring Diagram - Junction Box to Actuation Valves and Optical Encoder with External Z Channel (Home Sensor) Photo Sensor

# Section 4 - START UP & OPERATION

## 4-1 FRONT PANEL DESCRIPTION

(See Figure 4.1)

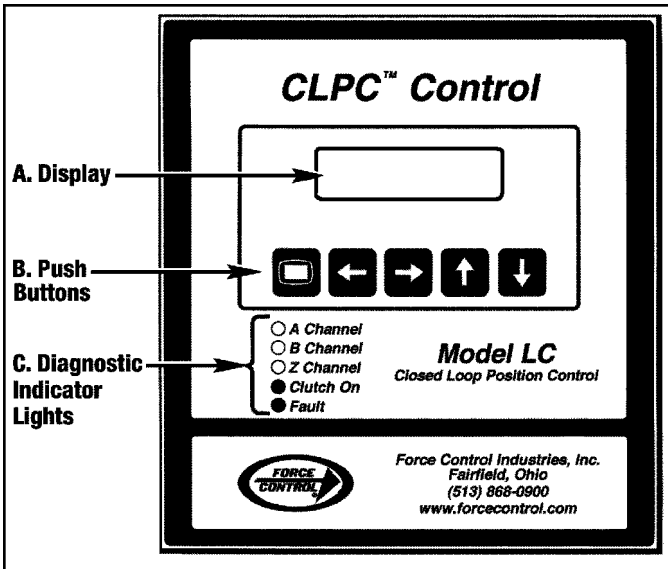

Figure 4.1 - CLPC LC Front Panel

### A. Displays (Run Mode Shown)

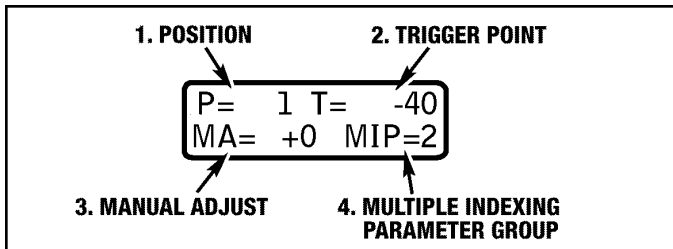

Figure 4.2 - Display

- 1. Position** - Shows the position count of the Encoder. See Section 4-4 (Manual Adjust) for example showing expected position.
- 2. Trigger Point** - This is the number of counts it takes to stop. If negative, the drive is rotating CW. If positive, the drive is rotating CCW. (Viewing the *Posidyne* output shaft.)
- 3. Manual Adjust** - Displays the manual adjustment to the Stopping Point. This adjustment is the number of pulses from the Home (Z Channel) marker.
- 4. Multiple Indexing Parameters (MIP)** - are inputs from a PLC or other source which allows the CLPCLC Control to select one of (16) different Indexing Parameter Groups. Each parameter group includes maximum count (index distance), manual adjust, in position range and the associated trigger. By turning the proper inputs on, a specific program can be selected and used by the control when the cycle start signal is received.

### B. Push Buttons



1. **Program** - Used to enter/exit the Program Mode.



2. **Menu Back** - Used to return to the previous menu list.



3. **Menu Forward & Fault Reset** - Used to advance forward through the menu list or to reset a fault.



4. **Increment (Up)** - Used to increase a parameter setting for the selected menu item.



5. **Decrement (Down)** - Used to decrease a parameter setting for the selected menu item.



### C. Diagnostic Indicator Lights

- 1. A Channel** - Indicates a pulse from "A" channel of the encoder. (**Yellow**)
- 2. B Channel** - Indicates a pulse from "B" channel of the encoder. (**Yellow**)
- 3. Z Channel** - Indicates a pulse from "Z" channel of the encoder, home sensor. (**Yellow**)
- 4. Clutch On** - Indicates when the clutch solenoid is energized. (**Green**)
- 5. Fault** - Indicates a control fault or when in the program mode. (**Red**)



## 4-2 OPERATING MODES



**The Menu System Operates in Two Modes...**

### A. Run Mode

While in the Run Mode, the display will only show the Position, Trigger Point, Manual Adjust and the currently selected Multiple Index Parameter (MIP) group number. The **Up**  and **Down**  buttons will automatically adjust the manual adjust parameter. No other adjustments can be made while in the Run Mode.

### B. Program Mode (See Figure 4.3)

Press the **Program**  button to enter the **Program Mode**. While in the program mode, a menu list will be accessible on the display and the Fault Output will be turned on. The first line will contain a description of the parameter and the second line will show the selected value for that parameter. Press the **Menu Forward**  button to advance through the menu list. If the control enters into a faulted state (displaying an error code) this button will reset the fault and return to run mode. Press the **MenuBack**  button to return to the previous Menu Item.

Use the **Up**  and **Down**  buttons to change the value for that parameter. Once complete with the programming, press the **Program**  button to return to the Run Mode. The control will not respond to Cycle Start commands while in the Program Mode. Default Settings are shown in **bold & italic** for each menu.

### Menu Parameters for Standard Control

1. Max Count	0 to 65535 ( <b><i>120</i></b> )
2. Manual Adjust	+/- 1/4 of max count ( <b><i>0</i></b> )
3. IP Window	+/- 1/4 of max count ( <b><i>4</i></b> )
4. Stall Detection	Off, <b><i>100 Msec</i></b> , 250 Msec
5. Watch Dog Timer	Off, 100 Msec, 150 Msec, 200 Msec, 250 Msec, <b><i>300 Msec</i></b> , 400 Msec, 500 Msec, 750 Msec, 1 sec, 2 sec, 2.5 sec, 5 sec, 7.5 sec, 15 sec, 30 sec, 45 sec & 1 min.
6. Encoder Multiplier	1X, <b><i>2X</i></b> & 4X
7. Encoder Wiring	<b><i>Single Ended</i></b> , Differential
8. Encoder Sense	<b><i>A + B Normal</i></b> , A + B Swapped
9. Home Wiring	<b><i>Single Ended</i></b> , Differential
10. Home Sense	<b><i>Zero at On</i></b> , Zero at Off
11. Control Mode	<b><i>Single Index</i></b> , Run til Release and Restart B4 Stop
12. No Motion	5 Msec, 10 Msec, 15 Msec, 20 Msec, <b><i>25 Msec</i></b> , 30 Msec, 40 Msec, 50 Msec, 75 Msec & 100 Msec.
13. Input Debounce	1 - 255 Msec ( <b><i>15</i></b> )
14. Version	a.b.c Target, Rev d Firmware
15. Node Number	<b><i>0</i></b> to 15 ( <i>For Future Use.</i> )

### Additional Menu Sequence and Values for MIP/PLS Card

16. PLS 1 On	Off, 0 to (max count - 1)
17. PLS 1 Off	Off, 0 to (max count - 1)
18. PLS 2 On	Off, 0 to (max count - 1)
19. PLS 2 Off	Off, 0 to (max count - 1)
20. PLS 3 On	Off, 0 to (max count - 1)
21. PLS 3 Off	Off, 0 to (max count - 1)
22. PLS 4 On	Off, 0 to (max count - 1)
23. PLS 4 Off	Off, 0 to (max count - 1)
24. Max Count MIP 0	0 to 65335
25. Manual Adj. MIP 0	+/- 1/4 of max count MIP 0
26. IP Window MIP 0	+/- 1/4 of max count MIP 0
27. Max Count MIP 1	0 to 65335
28. Manual Adj. MIP 1	+/- 1/4 of max count MIP 1
29. IP Window MIP 1	+/- 1/4 of max count MIP 1
30. Max Count MIP 2	0 to 65335
31. Manual Adj. MIP 2	+/- 1/4 of max count MIP 2
32. IP Window MIP 2	+/- 1/4 of max count MIP 2

33. Max Count MIP 3	0 to 65335
34. Manual Adj. MIP 3	+/- 1/4 of max count MIP 3
35. IP Window MIP 3	+/- 1/4 of max count MIP 3
36. Max Count MIP 4	0 to 65335
37. Manual Adj. MIP 4	+/- 1/4 of max count MIP 4
38. IP Window MIP 4	+/- 1/4 of max count MIP 4
39. Max Count MIP 5	0 to 65335
40. Manual Adj. MIP 5	+/- 1/4 of max count MIP 5
41. IP Window MIP 5	+/- 1/4 of max count MIP 5
42. Max Count MIP 6	0 to 65335
43. Manual Adj. MIP 6	+/- 1/4 of max count MIP 6
44. IP Window MIP 6	+/- 1/4 of max count MIP 6
45. Max Count MIP 7	0 to 65335
46. Manual Adj. MIP 7	+/- 1/4 of max count MIP 7
47. IP Window MIP 7	+/- 1/4 of max count MIP 7
48. Max Count MIP 8	0 to 65335
49. Manual Adj. MIP 8	+/- 1/4 of max count MIP 8
50. IP Window MIP 8	+/- 1/4 of max count MIP 8
51. Max Count MIP 9	0 to 65335
52. Manual Adj. MIP 9	+/- 1/4 of max count MIP 9
53. IP Window MIP 9	+/- 1/4 of max count MIP 9
54. Max Count MIP A	0 to 65335
55. Manual Adj. MIP A	+/- 1/4 of max count MIP A
56. IP Window MIP A	+/- 1/4 of max count MIP A
57. Max Count MIP B	0 to 65335
58. Manual Adj. MIP B	+/- 1/4 of max count MIP B
59. IP Window MIP B	+/- 1/4 of max count MIP B
60. Max Count MIP C	0 to 65335
61. Manual Adj. MIP C	+/- 1/4 of max count MIP C
62. IP Window MIP C	+/- 1/4 of max count MIP C
63. Max Count MIP D	0 to 65335
64. Manual Adj. MIP D	+/- 1/4 of max count MIP D
65. IP Window MIP D	+/- 1/4 of max count MIP D
66. Max Count MIP E	0 to 65335
67. Manual Adj. MIP E	+/- 1/4 of max count MIP E
68. IP Window MIP E	+/- 1/4 of max count MIP E
69. Max Count MIP F	0 to 65335
70. Manual Adj. MIP F	+/- 1/4 of max count MIP F
71. IP Window MIP F	+/- 1/4 of max count MIP F

**NOTE:** Menu parameters #16 to #71 will only be displayed if the optional MIP/PLS card is installed.

## 4-3 INITIAL SET-UP PROCEDURE

The **CLPC LC Control** operates by counting pulses from an incremental encoder and when a preset number of pulses [(Max Count ± Manual Adjust) - Trigger] is reached the brake is engaged to stop the drive in position.

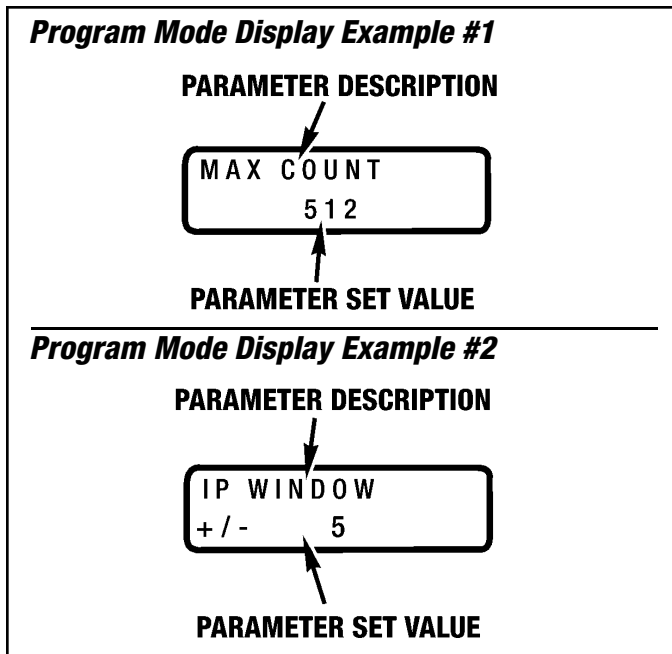

Figure 4.3 - Program Mode Display Examples

This Turn Off position, or Trigger Point, is continuously adjusted to provide accurate stopping.

### MENU PARAMETER #1 - Max Count

The **Max Count** is the total number of pulses to complete a single index or cycle. The **Max Count** is determined by the following formula:

1. **No. of Encoder Pulses per Revolution x Encoder Multiplier = Resolution (Pulses per Revolution)**  
(Example:  $60 \times 2 = 120$ )
2. **Resolution x Revolutions per Index = Max Count (Pulses per Index)**  
(Example:  $120 \times 10 = 1200$ )

The proper **Resolution** is critical for accuracy and usability of the control. It should be set to provide accurate positioning based on the requirements of the application. **Resolution** can be changed by choosing an encoder which furnishes more or fewer pulses per revolution, or changing the encoder **Ratio Multiplier** (number of counts per pulse)

#### STEP #1 (Setting Resolution for Max Count)

1. Set the Resolution with the **Menu Parameter #6** (Encoder Multiplier)
  - 1X Mode** - Control counts just the leading edge of each slot.
  - 2X Mode** - Control counts both the leading and trailing edge of each slot.
  - 4X Mode** - Control counts both the leading and trailing edge of each slot by each "A" & "B" Sensor.

#### STEP #2 (Determining Encoder Multiplier for Max Count)

Next determine the Number of Revolutions or Partial Revolutions the Encoder will turn in one index. If the encoder is not on the final drive shaft, the ratio between the final drive shaft and the encoder will have to be determined. Multiply the amount of rotation at the final drive shaft times the ratio of the Drive to determine the amount of rotation of the encoder.

This is multiplied by the Number of Pulses per Revolution, then times the Encoder Multiplier which determines the Max Count. In many cases a 60 slot pulse disc is used and an Encoder Multiplier of (2X), which would give a Count of 120 pulses per revolution. (See Example)

**Example:**

**Number of slots on Encoder - 60**

**Encoder Multiplier - 2X**

**Number of Encoder Revolutions per Index - 10**

**Max Count =  $60 \times 2 \times 10 = 1200$  Pulses**

Pulses per Revolution			Posidyne Size
1X	2X	4X	
<b>MAGNETIC SINGLE ENDED ENCODER</b>			
60	120	240	01, 1.5, 02, 2.5, 03, 05, 10, 11
90	180	360	20
<b>OPTICAL DIFFERENTIAL LINE DRIVER ENCODER</b>			
60	120	240	01, 1.5, 02, 2.5, 03, 05
90	180	360	10, 11, 20

#### STEP #3 (Setting Max Count)

1. Press the **Program**  Button to put the control into the Program Mode.





The first menu displayed will be the **Max Count** parameter.



2. Use the **Up**  and **Down**  buttons to set the Max Count to the desired setting. *The default setting is 120.*
3. Press the **Program**  button to return the control to the Run Mode.

### 4-4 REMAINING PARAMETER DESCRIPTIONS

#### A. General Procedure for Setting Parameters.

1. Press the **Program**  Button to put the control into the Program Mode.
2. Press the **Forward**  Button to index the control to the Menu Parameter.
3. Use the **Up**  and **Down**  buttons to adjust the selected parameter setting.

- Press the **Program**  button to return the control to the **Run Mode** after all parameter adjustments have been made.

### MENU PARAMETER #2 - Manual Adjust

The **Manual Adjust** allows the operator to adjust the Stop Position to some position before or after the physical Home Sensor Position. It is set in pulses of the encoder and can be positive or negative. A negative setting stops the drive before the physical Home Sensor Position and a positive setting stops the drive after the physical Home Sensor Position.

#### EXAMPLES:

- If the Manual Adjust is set to **+10** and the Max Count is set to **120**, the Target Stopping Position will be **10** (*10 counts past the Max Count and/or the Home Sensor Location.*)
- If the Manual Adjust is set to **-10** and the Max Count is set to **120**, the Target Stopping Position will be **110** (*10 counts before the Max Count and/or the Home Sensor Location.*)



The **Manual Adjust** is the only Menu Parameter that can be changed both in the **Run Mode** and **Program Mode**.

#### A. Setting Manual Adjust in the Run Mode

These changes though will not be accepted while the control is indexing.



P= 0 T= -60  
MA= +0 MIP=0

#### MANUAL ADJUST SETTING

- Push the **UP**  Button to enter a positive number and the **DOWN**  Button to enter a negative number. **The default setting is "0"**.

The adjustment range is plus or minus 1/4 of Max Count.

#### B. Setting Manual Adjust in the Program Mode

- Press the **Program**  Button to put the control into the Program Mode.
- Press the **Forward**  Button to index the control to the Manual Adjust Menu.

MANUAL ADJUST  
0

- Use the **Up**  and **Down**  buttons to set the Manual Adjust to the desired setting. **The default setting is 0.**
- Press the **Program**  button to return the control to the **Run Mode**.

### MENU PARAMETER #3 - IP WINDOW

The **IP (In Position) Window** selects the allowable tolerance for detecting a successful stop.

IP WINDOW  
+/- 4

#### EXAMPLE:

Max Count is set to 120, Manual Adjust = 0 and an IP Window of **+/- 4** is selected. When the CLPC LC control detects that the drive has stopped and the Position is detected to be +/- 4 counts from Max Count (**Position = 116 to 119; 0; 1 to 4**). The **In Position Output** will turn on signaling a successful and complete "**In Position**" index. If the position is detected to be outside of the selected window, the output will not turn on. If the encoder moves to a position outside the IP Window before the next start cycle the IP Output will turn off.

**The Default Setting is +/- 4.**

### MENU PARAMETER #4 - Stall Detection

**Stall Detection** selects the maximum time expected between the request to start (Valve is Energized) and when the drive begins to move. If no motion is detected within the selected period of time, an **Error Code E-43**

STALL DETECTION  
100 Msec

"**Did Not Start**" will be displayed

**The Default Setting is 100 Msec.**

### MENU PARAMETER #5 - Watch Dog Timer

The **Watch Dog Timer** is an internal device which will stop the drive if the cycle is not completed within a set amount of time. This feature is used to protect the clutch and other downstream equipment. When the Watch Dog Timer is exceeded, the control will end the cycle, which will release the clutch and engage the brake. This timer should be set at a time slightly greater than the longest cycle required.

WATCH DOG TIMER  
300 MSec

**The Default Setting is 300 Msec.**

## MENU PARAMETER #6 - Encoder Multiplier

The Encoder Multiplier enhances the Resolution of the Encoder by counting on additional edges of the input pulse train. **The Default Setting is 2X.**

ENCODER MULT  
2x

The settings are as follows:

- 1X Mode** - Control counts just the leading edge of each slot.
- 2X Mode** - Control counts both the leading and trailing edge of each slot.
- 4X Mode** - Control counts both the leading and trailing edge of each slot by each "A" & "B" Sensor.

## MENU PARAMETER #7 - Encoder Wiring

The Encoder Wiring selects between Single Ended and Differential. This setting must match the type of encoder used. **The Default Setting is Single Ended.**

ENCODER WIRING  
Single Ended

EXAMPLES:

- 1. Force Control Optical Encoder** - The Encoder Wiring needs to be set to **Differential** because there are two wires for each "A" and "B" Channel.
- 2. Force Control Magnetic Encoder** - The Encoder Wiring needs to be set to **Single Ended** because there is only one wire for each "A" and "B" Channel.

**IMPORTANT - Make sure that you check and set this parameter to match the type of Encoder that you may have.**

## MENU PARAMETER #8 - Encoder Sense

The Encoder Sense parameter allows the "A" and "B" Channels to be swapped (A + B Swapped) through software control. This eliminates the need to re-wire if the direction of rotation yields a positive trigger. **The Default Setting is A + B Normal.**

ENCODER SENSE  
A + B Normal

## MENU PARAMETER #9 - Home Wiring

The Home Wiring selects between Single Ended and Differential. This setting must match the type of encoder used. **The Default Setting is Single Ended.**

HOME WIRING  
Single Ended

EXAMPLES:

- 1. Force Control Optical Encoder** - The Home Wiring needs to be set to **Differential** because there are two wires for the "Z" Home Channel.
- 2. Force Control Magnetic Encoder with Internal Home Sensor, External Home Sensor or no Home Sensor at all** - The Home Wiring needs to be set to **Single Ended** because there is only one wire for the "Z" Home Channel.

**IMPORTANT - Make sure that you check and set this parameter to match the type of Encoder or Home Sensor that you may have.**

## MENU PARAMETER #10 - Home Sense

The Home Sense parameter sets the way the Home Sensor resets the Position Count. **Zero at ON** sets the control to zero the Position Count when the front panel Z channel LED goes from an Off state to an On state. Conversely, **Zero at Off** sets the control to reset the Position Count when the front panel Z channel LED goes from an On state to an Off state. **The Default Setting is Zero at ON.**

HOME SENSE  
Zero at ON

## MENU PARAMETER #11 - Control Mode

The Control Mode parameter has (3) settings. They are as follows:

- 1. Single Index** - The CLPC LC will initiate and run one complete cycle and stop for each Cycle Start request.
- 2. Run Til Release** - The CLPC LC will initiate and run. Once running, if the Cycle Start Input is still on at the Trigger Position, the control will continue running the drive. Once the Cycle Start Input is removed, the control will stop the drive at the next Trigger Point.
- 3. Restart B4 (Before) Stop** - The CLPC LC will initiate and run. Once running, this setting will perform just like the Run to Release with one addition. If the control has begun to stop the drive, it can be restarted with the Cycle Start Input before it comes to a complete stop.

CONTROL MODE  
Single Index

**The Default Setting is Single Index.**

---

---

## **MENU PARAMETER #12 - No Motion Timer**

The **No Motion Timer** parameter is used by the control to detect when the drive has stopped. For example, if the **No Motion Timer** is set to **25 MSec** and the time between encoder pulses coming into the control exceeds 25 MSec, the control will determine that the drive has stopped, evaluate the position and make any trigger adjustments. Also if the Position is within the "IP window", the In Position Output will be turned on. **The Default Setting is 25 MSec.**

**NO MOTION TIMER**  
25 MSec

## **MENU PARAMETER #13 - Input Debounce**

This **Input Debounce** parameter adjusts the amount of time before an Input Signal is acted upon by the CLPC LC control. This can be used to debounce noisy inputs or act as a programmable delay for synchronizing external sensors that initiate Cycle Start. The range is from 1 to 255 MSec. **The Default Setting in 15 MSec.**

**INPUT DEBOUNCE**  
15 MSec

## **MENU PARAMETER #14 - Version**

This is the System Software Version. It will be displayed momentarily upon Start-Up.

**VERSION**  
1.0.2      Rev A  
a.b.c      d

- a = Software Series
- b = Major Revision
- c = Minor Revision
- d = Firmware Revision

## **MENU PARAMETER #15 - Node Number**

Reserved for future use.

**NODE NUMBER**  
0

## Section 5 - TROUBLESHOOTING

### 5-1 POWER-UP SEQUENCE

Upon “**Power-Up**” several diagnostic tests are performed. These tests are as follows:

1. Display Character Test.
2. SRAM Test.
3. Firmware Test.
4. RS 232 Test.
5. System Revision Status.

**NOTE** - During this **Power-Up** Sequence, the Fault Output will be on.

### 5-2 DESCRIPTION OF FRONT PANEL

(See Figure 5.1)

Troubleshooting the **CLPC LC** Control is greatly simplified due to Indicator Lights and Error Codes built into the Front Control Panel. (See Figure 5.1) Section 5-1 describes the Front Control Panel and Section 5-2 describes the “Error Codes”. Corrective measures are also given to correct the “Fault” for each “Error Code”.



Figure 5.1 - Front Control Panel

#### A. DISPLAY

When an **Error** occurs it will be indicated in the display window as shown in Figure 5.1 above. The **Error Code Number** will be shown in the top line and the **Error Code Name** will be shown in the bottom line.

#### B. Push Buttons



1. **Program** - Used to enter the Program Mode.



2. **Menu Back** - Used to return to the previous menu list.



3. **Menu Forward & Fault Reset** - Used to advance forward through the menu list or to reset a fault.



4. **Increment (Up)** - Used to increase a parameter setting for the selected menu item.



5. **Decrement (Down)** - Used to decrease a parameter setting for the selected menu item.

#### C. Diagnostic Indicator Lights

1. **A Channel** - Indicates a pulse from “A” channel of the encoder. (**Yellow**)
2. **B Channel** - Indicates a pulse from “B” channel of the encoder. (**Yellow**)
3. **Z Channel** - Indicates a pulse from “Z” channel of the encoder, home sensor. (**Yellow**)
4. **Clutch On** - Indicates when the clutch solenoid is energized. (**Green**)
5. **Fault** - Indicates a control fault. (**Red**)

### 5-3 ERROR CODES

**A. General Procedure to correct a System Fault if any set parameter has to be changed:**

**Example:**

**Error Code E-4 Watchdog Timer expired.**



#### Step #1

Press the **Fault Reset**  button on the **CLPC LC** front panel or the remote fault reset input.

#### Step #2

If the application requires a change to the **Watch Dog Timer** then press the **Program**  button on the **CLPC LC**.

The **Max Count** display will come up.

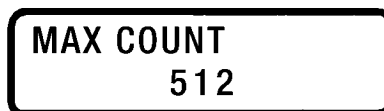

**FORCE CONTROL INDUSTRIES, INC.**

### Step #3

Press the **Forward**  button to advance to the **Watch Dog Timer** display.



### Step #4

Press the **Up**  or **Down**  button to set the **Watch Dog Timer** to the appropriate setting for your application. *The default setting is 300 Msec.*



**NOTE:** Default Settings are shown in the **Menu Sequence and Values for Standard Control** chart in the previous **Section 4-2 Operating Modes, B. Program Mode.**



### Step #5

Press the **Program**  button when finished to return the control to the **Run Mode.**

## B. Error Codes & Corrections

### 1. ERROR E-4 - WATCH DOG TIMER expired.

#### Correction:

- (a) Push the **Fault Reset**  button on the front control panel.
- (b) If Fault continues, adjust through the menu interface with the **Up**  or **Down**  buttons.
- (c) If the Watch Dog setting is adjusted to an appropriate value for the application and this Fault continues, verify that the drive is operating correctly.
- (d) Check the air supply to the control valve and the valve operation
- (e) Check to be sure that the motor is running and that the *Posidyne* is operating correctly. Be sure to check the *Posidyne* for any air leaks.
- (f) Check any drive belts to make sure that they are not loose or broken.
- (g) Verify that the home sensor is not producing a pulse that is re-zeroing the position count before the trigger position count is reached.

### 2. ERROR E-6 - TRIGGER > MC The counts required to stop is greater than the total MAX Count.

#### Correction:

- (a) Increase the total cycle or shorten the stopping time to be less than the total cycle.

### 3. ERROR E-13 - INVALID PLS VAL - Indicates an erroneous entry for a PLS setpoint has been detected and has been disabled.

#### Correction:

- (a) Readjust PLS Setpoint(s).

### 4. ERROR E-30 - SRAM ERROR - Indicates a fatal SRAM diagnostic error.

#### Correction:

- (a) Cycle power to **CLPC LC** control. If problem persists, replace the control.

### 5. ERROR E-31 - FIRMWARE ERROR - Indicates a fatal Firmware diagnostic error.

#### Correction:

- (a) Cycle power to **CLPC LC** control. If problem persists, replace the control.

### 6. ERROR E-32 - RS232 ERROR - Indicates a fatal RS232 diagnostic error.

#### Correction:

- (a) Disconnect cables/wires from Communication Port.
- (b) Cycle power to **CLPC LC** control. If problem persists, replace the control.

### 7. ERROR E-43 - DID NOT START - Indicates a failure to start. (Stall Detection)

#### Correction.

- (a) Check to be sure machine is not jammed.
- (b) Check to be sure motor is running and *Posidyne* input and output shaft are rotating.
- (c) Check air supply to control valve.

### 8. ERROR E-44 - DRIVE STALLED - Indicates the drive stalled while clutch was engaged.

#### Correction.

- (a) Check to be sure machine is not jammed.
- (b) Check to be sure motor is running and *Posidyne* input and output shafts are rotating.
- (c) Check air supply to control valve.

### 9. ERROR E-60 - CYCLE ABORTED - Indicates an external request (via Abort Cycle Input) to abort/discontinue an index has been accepted.

#### Correction:

- (a) Remove external request and reset fault with Remote Fault Reset or the **Fault Reset**  button on the **CLPC LC** front control panel.

### 10. ERROR E-80 - SOFTWARE CHANGED - (E-Prom software was changed from one version to another.) All parameters will be set to their default.

**Correction:**

(a) Push **Fault Reset** button on the **CLPC LC** front control panel or the Remote Fault Reset.

- 11. **ERROR E-81 - INVALID CONFIG** - Configuration corrupted. All parameters will be set to their default.

**Correction:**

(a) Push **Fault Reset** button on the **CLPC LC** front control panel or the Remote Fault Reset.

(b) Cycle power to the **CLPC LC** control. If problem continues, replace the control.

**5-4 OTHER ERROR DISPLAY**

- 1. **ENCODER OVERRUN** - High Speed Interrupt (Pulses per Second too high). Maximum allowable counts per second of Pulse Counter is 7200 counts per second. (See below.)

**Corrections:**

(a) Change Encoder Multiplier or Encoder to reduce maximum counts per second to be less than 7200.

(b) Verify that all encoder wiring is secure and the cable shield is properly attached to the CLPC DC return **only**.

(c) Check other devices in the system that may be producing higher than normal electro-magnetic interference. (i.e. Variable Frequency Drives.)

(d) Verify that the encoder is operating properly.

- 2. **FIRMWARE OVERRUN** - Indicates that the Firmware Interrupt has overrun the processor. (See below.)

**Corrections:**

(a) Verify that the home sensor is operating properly and all its' associated wiring is connected properly.

Also verify that if an external Home is used, that the Home Wiring Parameter is set to Single Ended.

(b) Check other devices in the system that may be producing higher than normal electro-magnetic interference. (i.e. Variable Frequency Drives.)

(c) Verify that the encoder is operating properly.

To remove indicators push the **Fault Reset** Button or remote Fault Reset Input.

**ENCODER OVERRUN INDICATOR**

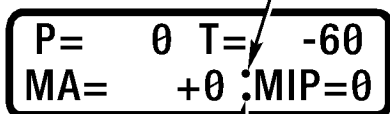

**FIRMWARE OVERRUN INDICATOR**

**5-5 TROUBLE SHOOTING AREAS**

Trouble shooting the **CLPC LC** Control is divided into (5) five areas based on the symptoms. The basic areas are:

- A. DRIVE WILL NOT INDEX**
- B. DRIVE STOPS OUT OF POSITION (Same position each time.)**
- C. DRIVE STOPS OUT OF POSITION (Different position each time.)**
- D. DRIVE DOES NOT STOP**
- A. DRIVE WILL NOT INDEX**

- 1. **“Fault” light on and “Error Code” in Display.**

(a) Push **Fault Reset** button on front control panel.  
(b) If this does not clear the Fault, check the Error Codes in Section 5-2.

- 2. **Motor not running.**

(a) Check the drive motor, relay, fuses, motor starter and interlock. Correct any problem and re-start.

- 3. **Clutch does not engage.**

(a) Check air pressure. (See All Products Catalog for Torque vs. Pressure Information.)

(b) Check the Solenoid Valve for proper operation and replace if necessary.

(c) Check the air lines for any leaks. Repair leaks or fittings.

(d) Check clutch/brake for proper mechanical operation.

- 4. **Watchdog Timer times out and shuts off control.**

(a) Push **Fault Reset** button on the **CLPC LC** front control panel or the Remote Fault Reset.

(b) Check machine to see why it timed out.

**B. DRIVE STOPS OUT OF POSITION (Same position each time.)**

- 1. **Caused by an incorrect setting in the Manual Adjust.**

(a) Set Manual Adjust to stop in the correct position. **NOTE:** Manual Adjust will remain in the system even if the control is off.

- 2. **Caused by home sensor not near desired stopping position and cannot be corrected by manual adjust. (Manual Adjust out of range.)**

(a) Realign Home Sensor to position near desired stopping position.

- 3. **Max Count not adjusted properly.**

(a) Check count and ratio to assure that the number of revolutions at the Encoder equals the desired degree of rotation of the driven machine



## Section 6 - REPAIR & REPLACEMENT

### 6-1 REMOVAL AND DISASSEMBLY OF THE OPTICAL ENCODER

(See Figure 7.3 and 7.4)

Any Drive Sheaves, Pulleys or Couplings must first be removed from the output shaft.

1. Take out the (4) Screws (#225) and remove the Top Cover (#372) and the upper Gasket (#19) from the Upper Enclosure (#18). This gasket is reusable.
2. Pull the Insulator (#373) up and out of the Upper Enclosure (#18).
3. Loosen the (2) captive screws in the Cable Connector (#368) and unplug it from the Circuit Board (#355). (See Figure 6.1)

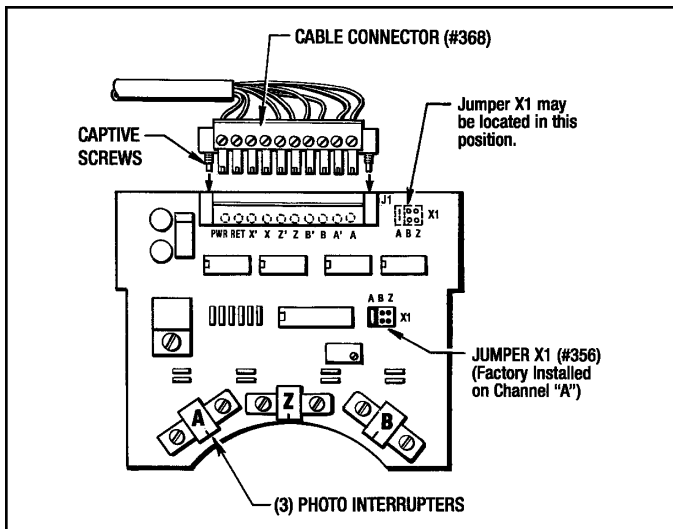

Figure 6.1 - Circuit Board Connector

4. Pull the Cable Grommet (#260), Cable (#259) and Cable Connector (#368) out of the Top Enclosure slot.
5. Remove the (2) Cap Screws (#77) and take the Upper Enclosure (#18) and lower Gasket (#19) off of the Disc Housing (#17). This gasket is also reusable.
6. Pull the Circuit Board (#355) straight up and out of the Disc Housing (#17).

#### (Sizes 01, 1.5 and 02 Posidyne)

7. Remove the (4) Screws (#76) and (4) Lockwashers (#257) and pull the Disc Housing off the Posidyne mounting face.

#### (Sizes 2.5, 03 and 05 Posidyne)

7. Remove the (4) Screws (#76) and pull the Disc Housing off the Posidyne mounting face.

#### (Sizes 10, 11 and 20 Posidyne)

7. Remove the (4) Screws (#76) and (4) Lockwashers (#32) and pull the Disc Housing off the Posidyne mounting face.

**CAUTION - Be very careful not to bump or bend the Optical Disc (#186) which is still attached to the output shaft or damage the Dirt Seal (#269) in the Disc Housing (#17).**

#### (All Posidyne Sizes)

8. If the Posidyne still has the main driving key in the output shaft, remove it at this time.
9. Loosen the Set Screw (#154) and pull the Optical Disc Assembly (#186) off of the output shaft.
10. Remove the Key (#234) from the output shaft.

**Note - On Size 2.5 Posidyne, also remove the Spacer (#270).**

11. Check the Dirt Seal (#269) in the Disc Housing (#17) and remove it if necessary.

### 6-2 REASSEMBLY AND INSTALLATION OF OPTICAL ENCODER

(See Figure 7.3 and 7.4)

1. If the Key (#234) was previously removed, install it into the output shaft, except for the 2.5 Posidyne.

#### (Size 01 and 1.5 Posidyne)

2. Slide the Optical Disc Assembly (#186) onto the output shaft and position as shown in Figures 6.2. The positioning of this Optical Disc Assembly must be accurate.

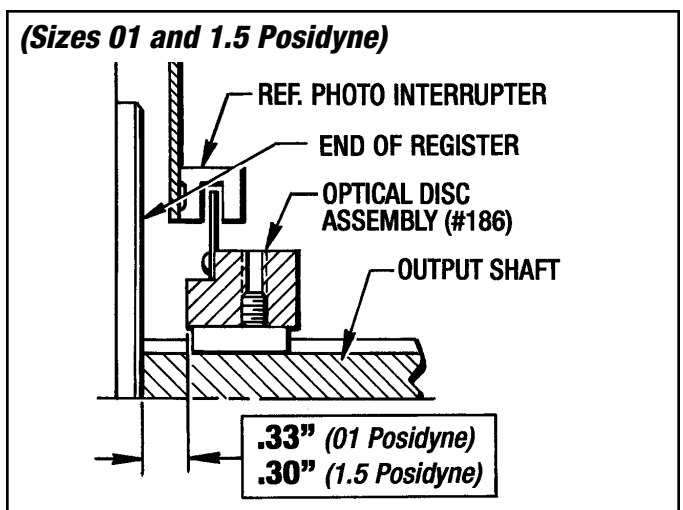

Figure 6.2 - Optical Disc and Hub Positioning (Sizes 01 AND 1.5 Posidyne)

**(Size 02 Posidyne)**

- Slide the Optical Disc Assembly (#186) onto the output shaft and position as shown in Figure 6.3. The positioning of this Optical Disc Assembly must be accurate.

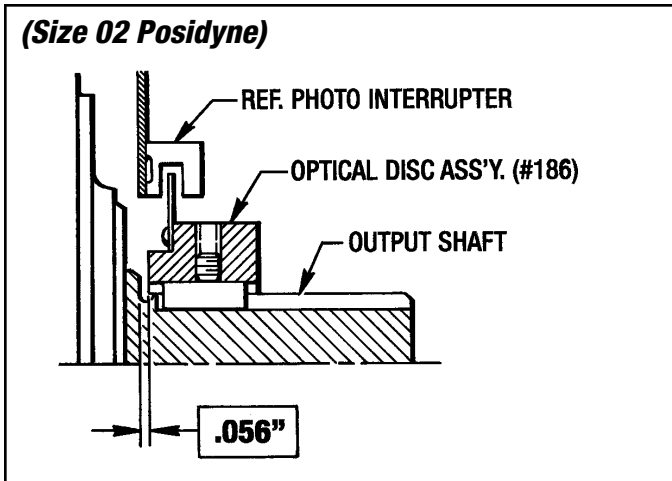

Figure 6.3 - Optical Disc and Hub Positioning (Size 02 Posidyne)

**(Size 2.5 Posidyne)**

- First slide the Spacer (#270) onto the output shaft as far as it will go. Install Key (#234), then slide the Optical Disc Assembly onto the output shaft, butting it up against the Spacer. (See Figure 6.4)

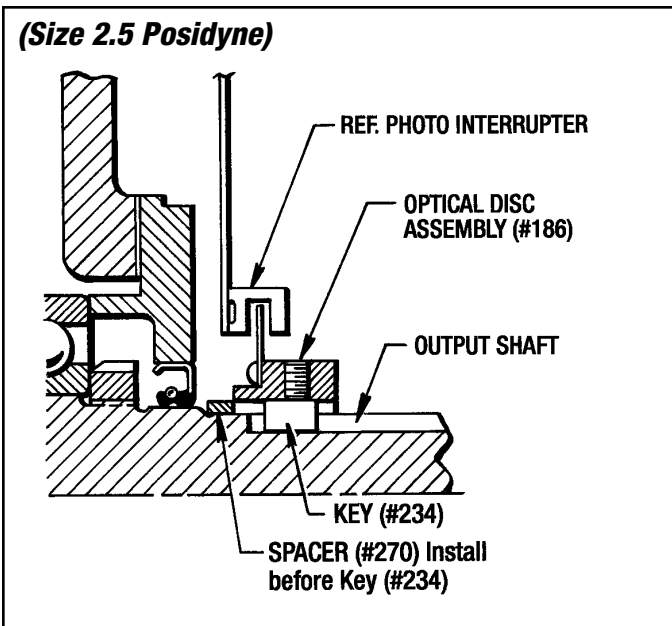

Figure 6.4 - Optical Disc and Hub Positioning (Size 2.5 Posidyne)

**(Sizes 03 and 05 Posidyne)**

- Slide the Optical Disc Assembly (#186) onto the output shaft until the Optical Disc Hub butts up against the Locknut on the output shaft. (See Figure 6.5)

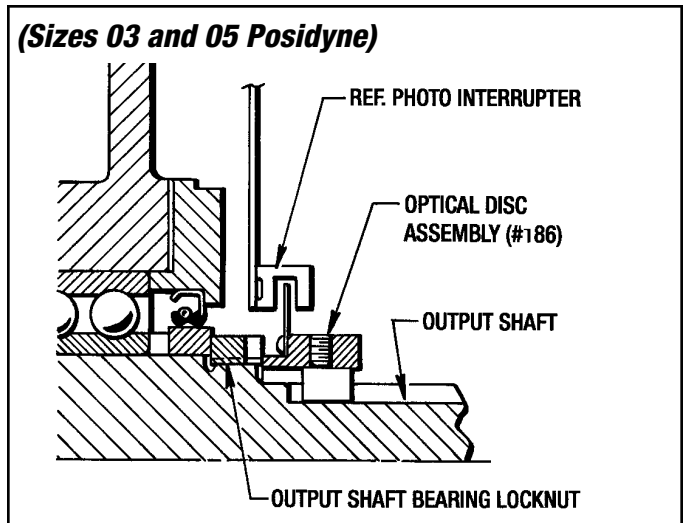

Figure 6.5 - Optical Disc and Hub Positioning (Sizes 03 and 05 Posidyne)

**(Sizes 10 and 11 Posidyne)**

- Slide the Optical Disc Assembly (#186) onto the output shaft until it butts up against the shoulder. See Figure 6.6 for Size 10 Posidyne and Figure 6.7 for Size 11 Posidyne.

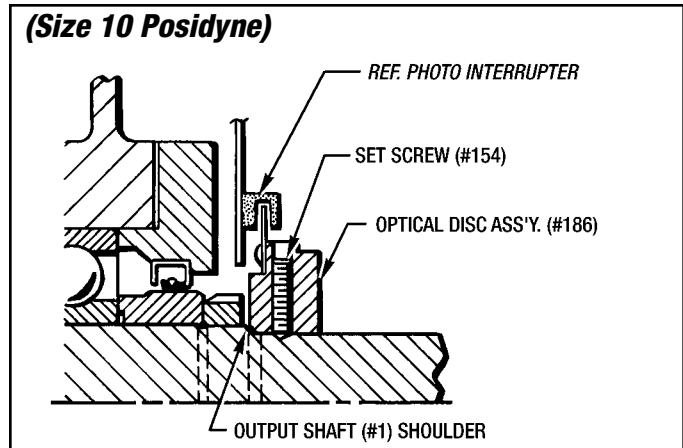

Figure 6.6 - Optical Disc and Hub Positioning (Size 10 Posidyne)

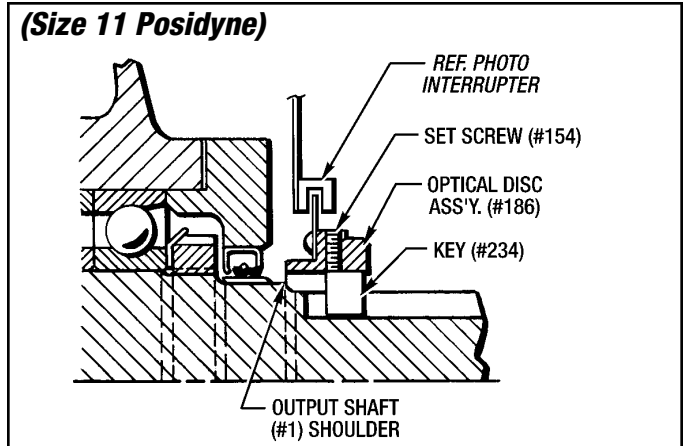

Figure 6.7 - Optical Disc and Hub Positioning (Size 11 Posidyne)

**(Size 20 Posidyne)**

- Slide the Optical Disc Assembly (#186) onto the output shaft until it butts up against the Locknut (#15) as shown in Figure 6.8 below.

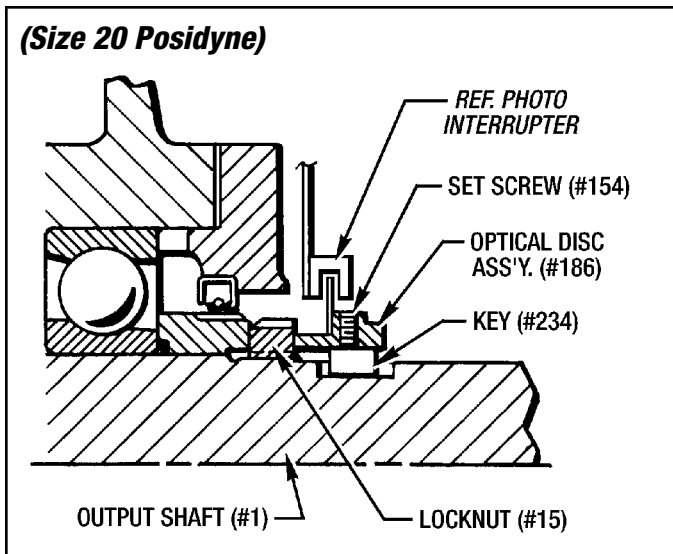

Figure 6.8 - Optical Disc and Hub Positioning (Size 20 Posidyne)

**(All Sizes Posidyne)**

- Tighten Set Screw (#154) and recheck the Hub position on the output shaft.
- Apply a light coat of grease to the Optical Disc Hub where the Dirt Seal (#269) rides.
- If the Dirt Seal (#269) was removed then install it into the Disc Housing (#17).
- Attach the Disc Housing (#17) to the output end of the Posidyne with the (4) Screws (#76).

**NOTES:**

- On sizes 01, 1.5 and 02 there will also be (4) Lockwashers (#257).
- On sizes 10, 11 and 20 there will also be (4) Lockwashers (#32).
- Place the Gasket (#19) on top of the Disc Housing.
- Carefully insert the Circuit Board (#355) into the top of the Disc Housing making sure the (3) Photo Interrupters straddle the Optical Disc. (See prior Figures 6.2, 6.3, 6.4, 6.5, 6.6, 6.7 and 6.8)
- While holding the Circuit Board upright slide the Upper Enclosure (#18) down over the Circuit Board onto the Disc Housing. Make sure the edges of the Circuit Board are in the (2) side retaining slots located in the Upper Enclosure. (See Figure 6.9)
- Check the Gasket (#19) to see if it is still in place. Insert the (2) Screws (#77) and tighten down.

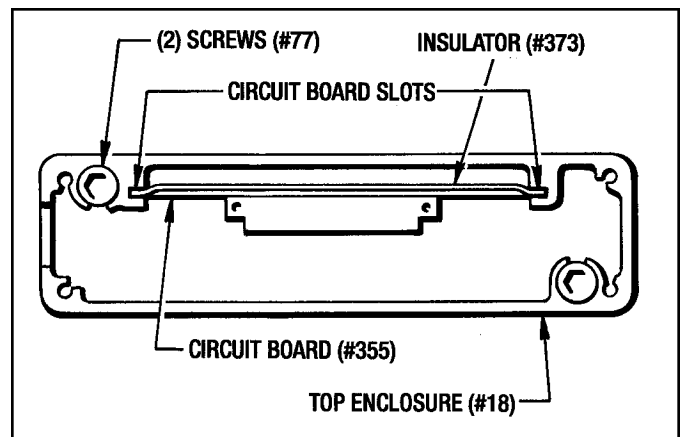

Figure 6.9 - Circuit Board Slots

- Slide the Insulator (#373) down and into the Upper Enclosure (#18) behind the Circuit Board (#355) placing the upper tabs into the circuit board slots.
- Place the Cable Grommet (#260) and Cable (#259) into the upper slot and plug in the Cable Connector (#368) to the Circuit Board Connector.
- Place the top Gasket (#19) on the Upper Enclosure and attach the Top Cover (#372) with (4) Screws (#225).

---

---

## Section 7 - ORDERING REPAIR PARTS

### 7-1 GENERAL INFORMATION

This section illustrates, lists and describes all available Repair Parts for the Force Control *CLPC LC* Control and related equipment. Exploded views with numbers are used to identify the various parts in the Control Unit. These numbers are listed in the parts list along with the part name and quantity used.

### 7-2 FACTORY RE-BUILD SERVICE

Re-conditioning service is offered by Force Control Industries at the factory. Before returning a unit for this service, be sure to first contact the Force Control Industries Service Sales Dept. for authorization and shipping instructions. Force Control Industries cannot be responsible for units returned to the factory without prior notice or authorization.

Care must be given to the packaging of returned drives. Always protect mounting feet by attaching to a skid. Shipment-damaged drives always delay repairs. When possible, describe the problem experienced on your shipping papers.

### 7-3 ORDERING REPAIR PARTS

There are no serviceable parts internally in the CLPC LC Control. Any servicing or replacing parts must be performed by Force Control authorized personnel or returned to the factory. (See Limited Warranty in front of this manual for returned goods authorization procedure.)

When ordering replacement parts, please specify all of the following information:

1. Control Model Number (See unit sticker.)
2. Control Serial Number (See unit sticker.)
3. Part Reference Number.
4. Part Name.
5. Quantity.
6. Complete shipping Information.

Failure to include information for items 1 through 6 will only delay your parts order. Unless another method is specified for item 6, parts less than 70 pounds will be shipped United Parcel Service, parts over 70 pounds will be shipped motor freight. Air freight and other transportation services are available, but only if specified on your order.

#### SHIPPING ADDRESS:

Force Control Industries, Inc.  
3660 Dixie Highway  
Fairfield, Ohio 45014  
Telephone: (513) 868-0900  
Fax: (513) 868-2105  
E-Mail: [info@forcecontrol.com](mailto:info@forcecontrol.com)

# 7-4 CLPC LC MODEL NUMBERS

**Standard: 01-59-14-BSAAANNN-00**

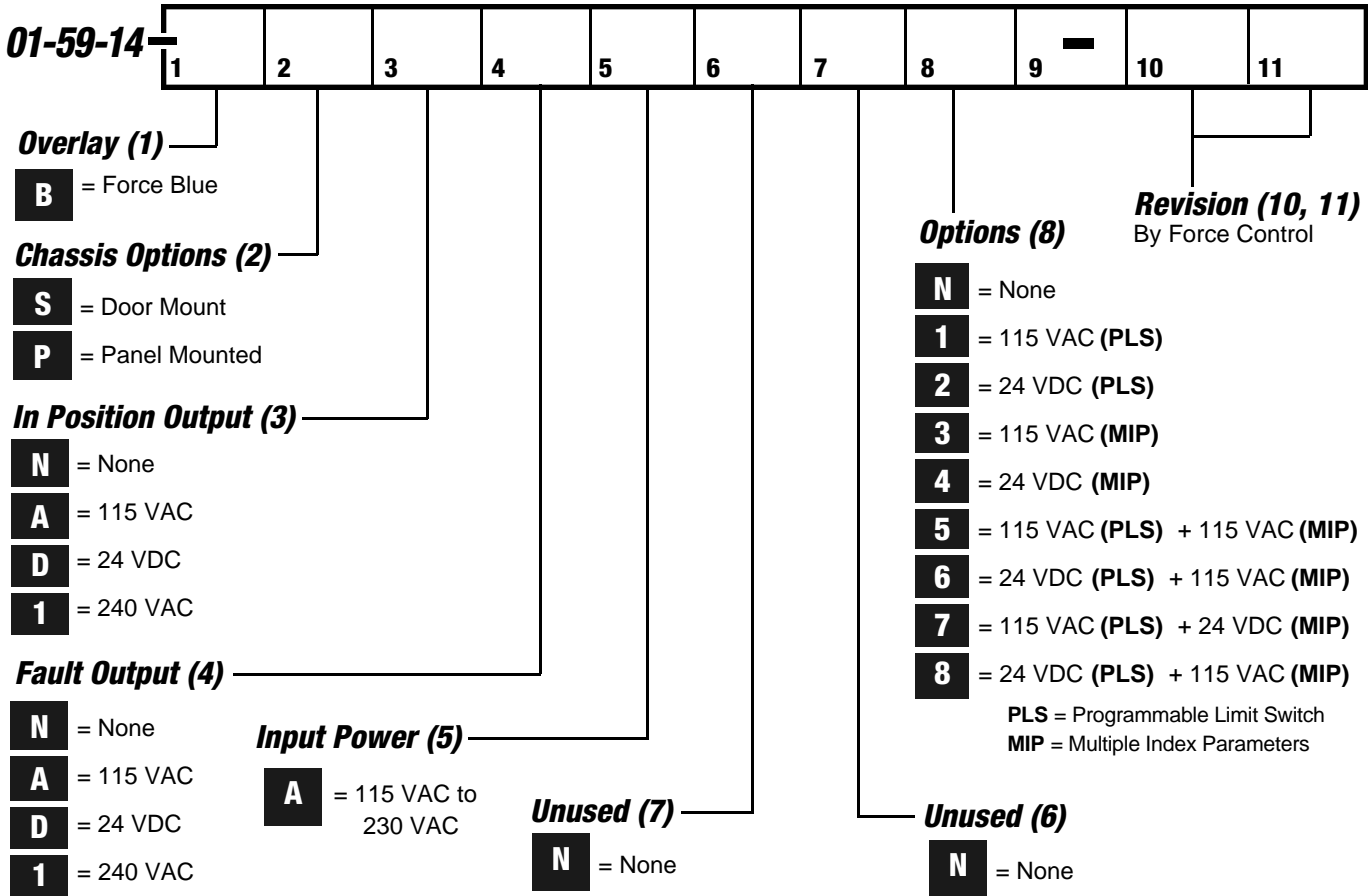

# 7-5 CLPC LC UNIT STICKER

**J4 PLS OUTPUTS & MIP INPUTS**

1	2	3	4	5	6	7	8	9	10	11	12	13	14	15	16
□	□	□	□	□	□	□	□	□	□	□	□	□	□	□	□

PLS 4 SWITCHED  
PLS 3 SWITCHED  
PLS 2 SWITCHED  
PLS 1 SWITCHED  
MIP 3 RETURN  
MIP 4 RETURN  
MIP 3 RETURN  
MIP 4 RETURN  
MIP 2 INPUT  
MIP 1 INPUT

**J1 POWER**

1	2	3
□	□	□

LINE  
EARTH GROUND

**J2, INPUTS AND OUTPUTS**

1	2	3	4	5	6	7	8	9	10	11	12	13	14	15	16
□	□	□	□	□	□	□	□	□	□	□	□	□	□	□	□

FAULT OUTPUT POWER  
FAULT SWITCHED  
IN POSITION OP POWER  
IN POSITION SWITCHED  
FAULT RESET INPUT, DC  
FAULT RESET INPUT, AC  
CYCLE START INPUT, DC  
CYCLE START INPUT, AC  
ABORT CYCLE INPUT, DC  
ABORT CYCLE INPUT, AC  
ABORT CYCLE COMMON  
OLUTCH COIL, SWITCHED  
OLUTCH COIL, +24VDC

**J3 ENCODER**

1	2	3	4	5	6	7	8	9	10
□	□	□	□	□	□	□	□	□	□

CHANNEL A (HOME)  
CHANNEL B (HOME)  
CHANNEL Z (HOME)  
CHANNEL Z (HOME)  
PROGRAM LOCK +  
PROGRAM LOCK -  
+12VDC  
+5VDC  
DC GROUND  
+24VDC  
DC GROUND

**COM PORT**

1	2	3	4	5	6	7	8	9
□	□	□	□	□	□	□	□	□

1 DCC  
2 TD  
3 RD  
4 DT  
5 GND  
6 DR  
7 RT  
8 CT  
9 GND

Force Control Industries Inc.  
CLPC Model LC

**ELECTRICAL RATINGS**

Input Voltage: 85-248VAC, 47-63Hz., 100W Max.  
Auxiliary Output Supply: 12VDC, 1Amp, Current limited.  
Solid State Inputs: 115VAC, Fused at 1/16Amps  
24VDC, Fused at 1/16Amps  
Solid State Outputs: 115VAC, Fused at 3Amps  
24VDC, Fused at 3Amps  
Clutch/Brake Output: 24VDC, 1A Max., Fused at 3Amps  
Encoder Inputs: Impedance: 220 Ohm to +5VDC Int.  
Voltage: 0-3VDC Low, 2-12VDC High.  
Frequency: 7.2KHz Max.

**ENVIRONMENTAL**

Enclosure Type (Indoor Only): NEMA 1, IP20 Enclosure  
NEMA 4, IP66 When Door Mounted  
Operating Temp: 0-60C (32-140F)  
Storage Temp: -18-85C (0-186F)  
Humidity: 90% Non-condensing  
Vibration: 2.5g's, 30 to 200Hz

Model Number: 01-59-14-

Serial Number:

## CLPC LC Control

(Figure 7.1)

PART REF. No.	PART NAME	QTY.
3	Gasket, CLPC LC Door Mounting . . . . .	1
11	Keq Nut, #6-32 . . . . .	8
14	Receptacle, 3-Pin . . . . .	1
15	Receptacle, 12-Pin . . . . .	1
16	Receptacle, 15-Pin . . . . .	1
18	Receptacle, 16-Pin . . . . .	1

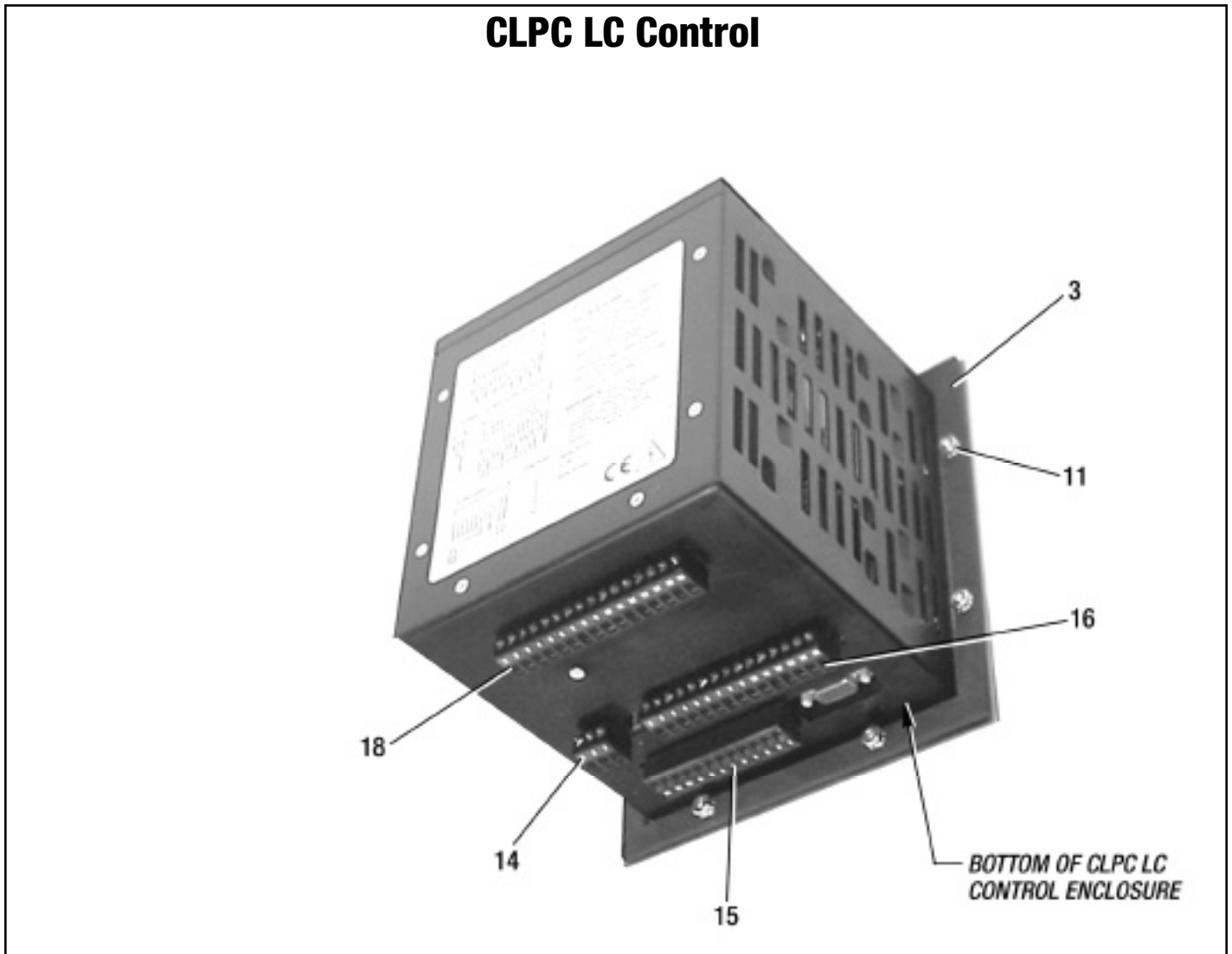

Figure 7.1 - CLPC LC Control

## Optional Junction Box

(Figure 7.2)

PART REF. No.	PART NAME	QTY.
40	Junction Box .....	1
41	Terminal Block .....	15
42	Cable, 3 Pin Connector .....	1
43	Cable, 4 Pin Connector .....	1
44	Cable, 5 Pin connector .....	1

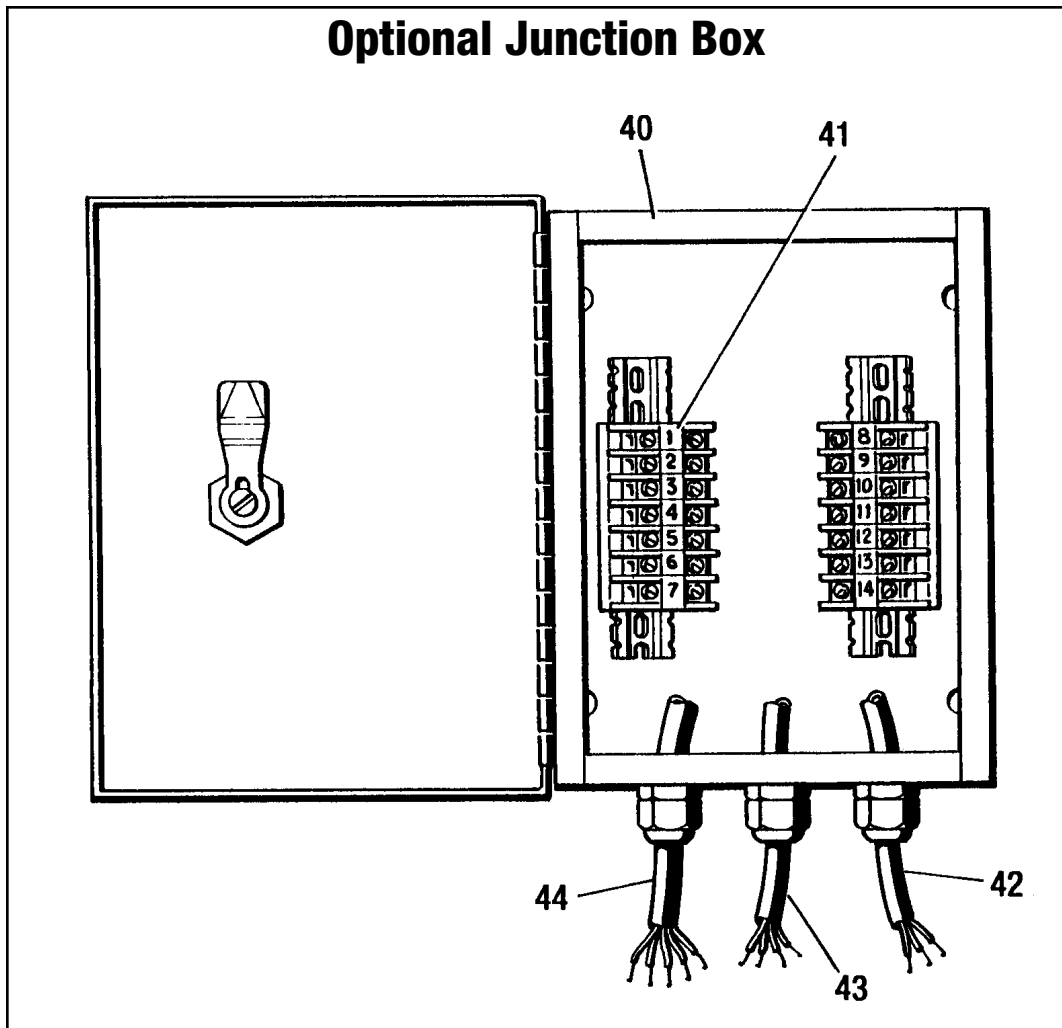

Figure 7.2 - Optional Junction Box

## Optical Encoder (Sizes 01 to 05 Posidyne) (Figure 7.3)

PART REF. No.	PART NAME	QTY.	PART REF. No.	PART NAME	QTY.
17	Disc Housing	1	259	Cable	1
18	Upper Enclosure	1	260	Cable Grommet	1
19	Gasket	2	269	Dirt Seal	1
76	Hex Hd. Screw	4	270	Spacer (2.5 Posidyne Only)	1
77	Soc. Hd. Screw	2	355	Circuit Board	1
154	Set Screw	1	356	Jumper	1
186	Optical Disc Assembly	1	368	Cable Connector	1
225	But. Hd. Screw	4	372	Top Cover	1
234	Key	1	373	Insulator	1
257	Lock Washer	4			

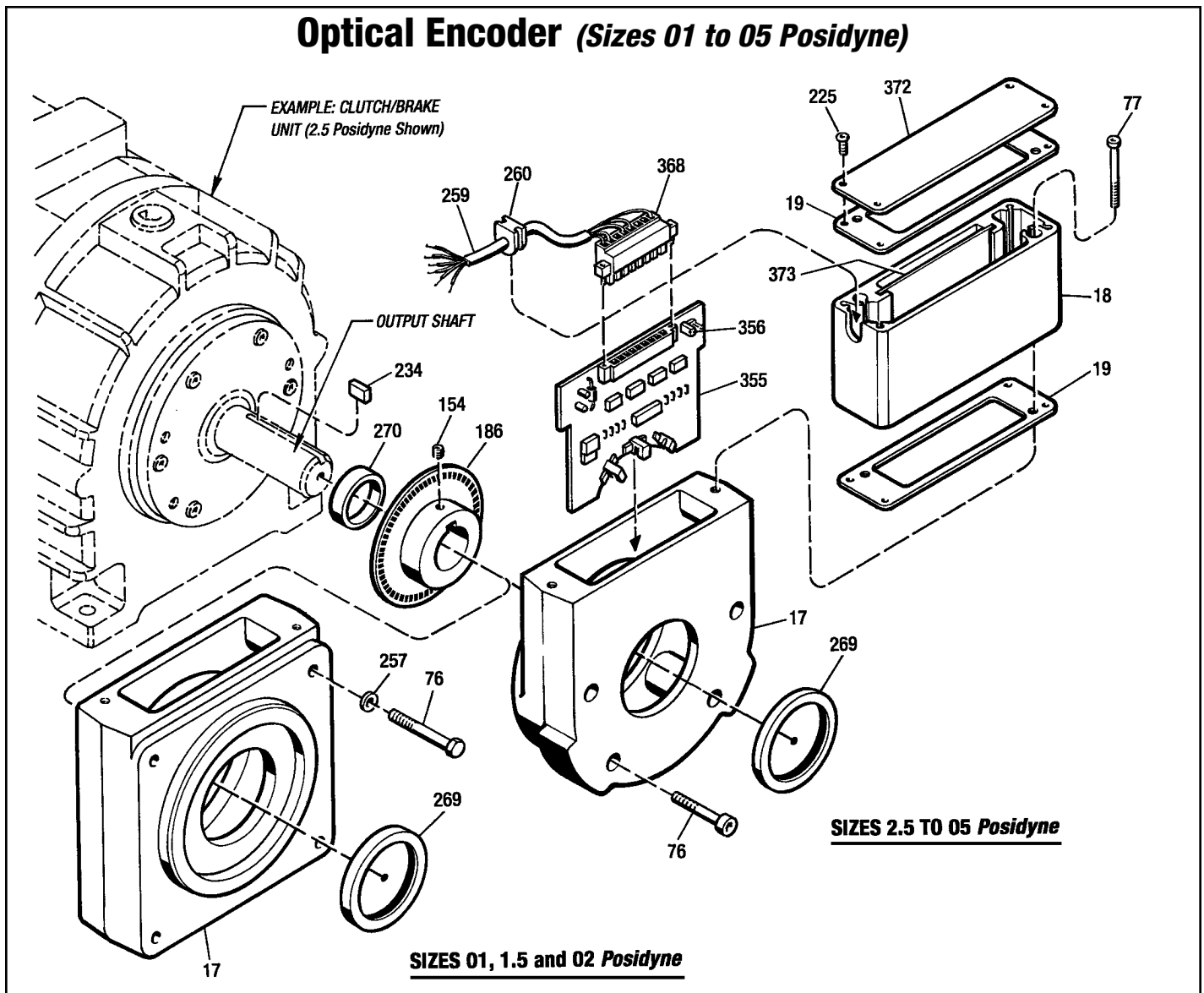

Figure 7.3 - Optical Encoder - (Sizes 01 to 05 Posidyne)

## Optical Encoder (Sizes 10, 11 and 20 Posidyne) (Figure 7.4)

PART REF. No.	PART NAME	QTY.	PART REF. No.	PART NAME	QTY.
17	Disc Housing	1	234	Key	1
18	Upper Enclosure	1	257	Lock Washer	4
19	Gasket	2	259	Cable	1
32	Lockwasher	4	260	Cable Grommet	1
76	Hex Hd. Screw	4	269	Dirt Seal	1
77	Soc. Hd. Screw	2	355	Circuit Board	1
154	Set Screw	1	356	Jumper	1
184	Dowel Pin	2	368	Cable Connector	1
186	Optical Disc Assembly	1	372	Top Cover	1
225	But. Hd. Screw	4	373	Insulator	1

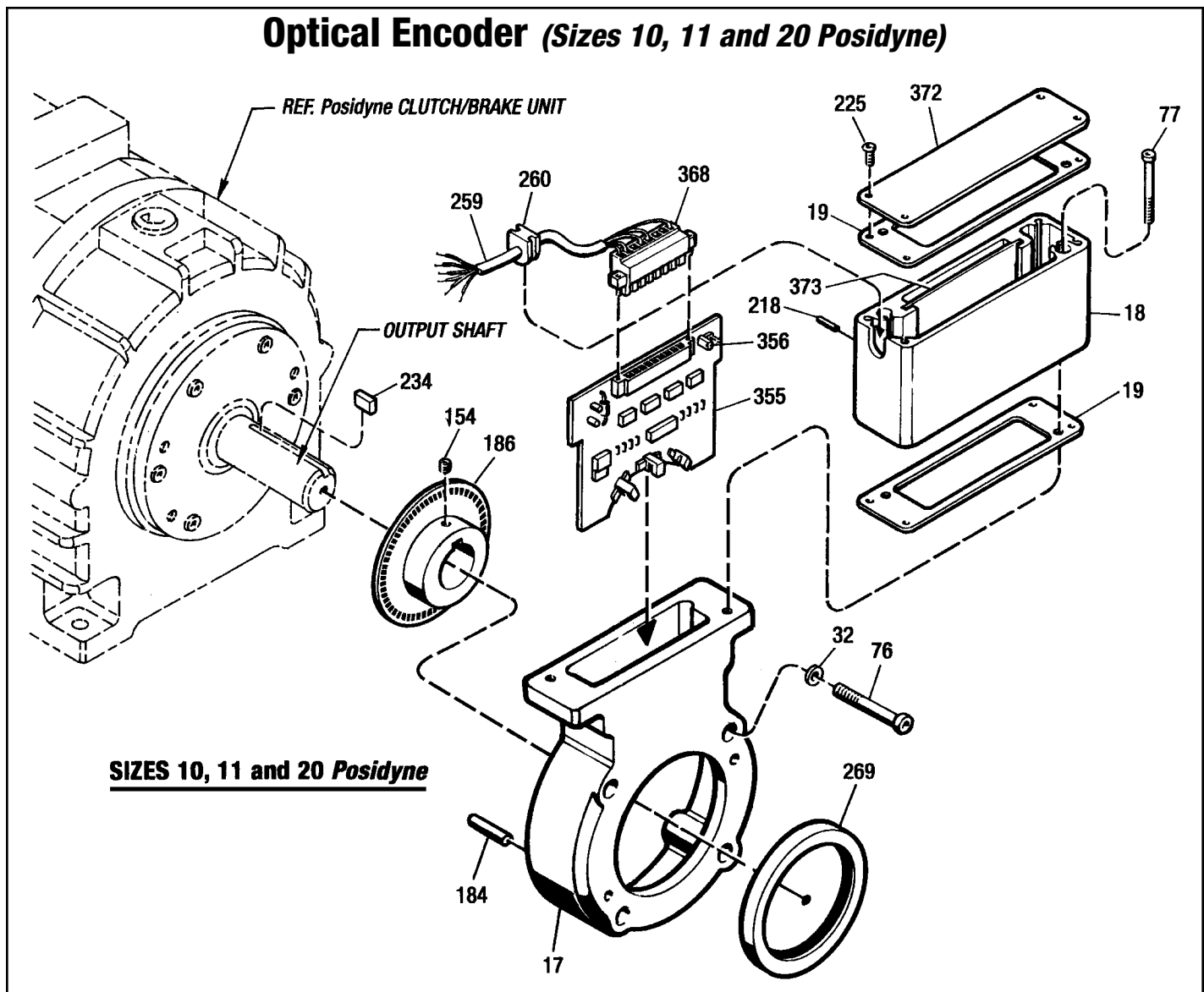

Figure 7.4 - Optical Encoder - Sizes 10, 11 and 20 Posidyne

---

---

## CLPC LC Software/Firmware Revision History

DATE	REV. #	FEATURE/IMPROVEMENT	NOTES
4/17/2000	1.0.2-A	Initial Production Release	
6/20/2000	1.0.4-A	Changed E7 and E14 Display Indication	

# **FORCE CONTROL INDUSTRIES, INC.**

*Worldwide Leader in "Oil Shear" Product Design*

*Providing today's industries  
with Oil Shear Clutch and  
Brake Drives that deliver...*

- *Flexibility*
- *Performance*
- and ● *Dependability*

---

---

**"BUILT TO LAST - GUARANTEED TO PERFORM"**

---

---



## **FORCE CONTROL INDUSTRIES, INC.**

### **MAIN OFFICE**

P.O. Box 18366  
Fairfield, Ohio 45018

3660 Dixie Highway  
Fairfield, Ohio 45014

Tel: (513) 868-0900  
Fax: (513) 868-2105

### **DETROIT OFFICE**

24419 Sorrentino Court  
Clinton Twp., Mich. 48035

Tel: (810) 772-7100  
Fax: (810) 792-7329

E Mail: [info@forcecontrol.com](mailto:info@forcecontrol.com)  
Web Page: [www.forcecontrol.com](http://www.forcecontrol.com)