

(Supplemental Instruction Sheet for Service Manual 502-11/20-001-01)

CLPC LC Control and Open Collector Quadrature (Magnetic) Encoder

TERMINAL BLOCK J3

A. With Internal Home Sensor (See Figure 1)

TERMINAL BLOCK J3

Terminal #1	Program Lock Input Power
Terminal #2	Program Lock Return
Terminal #3	Power, +12 VDC
Terminal #4	VDC Ground
Terminal #5	Power, +12 VDC
Terminal #6	VDC Ground
Terminal #7	B' (Compliment) - Channel (Not Used)
Terminal #8	B - Channel
Terminal #9	A' (Compliment) - Channel (Not Used)
Terminal #10	A - Channel
Terminal #11	Z' (Compliment) - Home Channel (Not Used)
Terminal #12	Z - Home Channel

NOTES:

1. The Internal Home Sensor uses the same power as the Magnetic Encoder.
2. Encoder wiring shown is for C.W. rotation of *Posidyne* output shaft. If C.C.W. rotation is desired reverse "A" and "B" encoder signals or change the Encoder Sensor setting through the menu interface.
3. Encoder Channel "A" must lead Channel "B". Slowly rotate the *Posidyne* output shaft in a the proper direction and check to be sure the Position Display counts up. If they don't, change the Encoder Sensor setting through the menu interface.

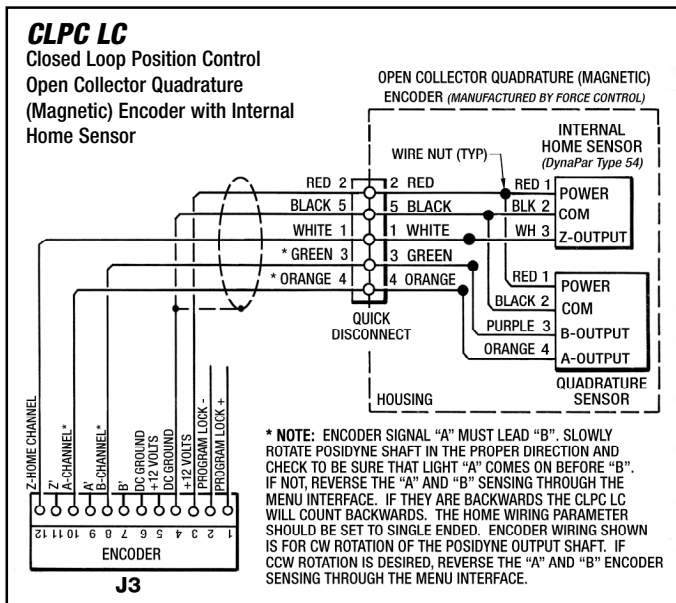

Figure 1 - Wiring Diagram - Terminal Block #J3 (With Internal Home Sensor)

B. With External Home Sensor (See Figure 2)

TERMINAL BLOCK J3

Terminal #1	Program Lock Input Power
Terminal #2	Program Lock Return
Terminal #3	Power, +12 VDC
Terminal #4	VDC Ground
Terminal #5	Power, +12 VDC
Terminal #6	VDC Ground
Terminal #7	B' (Compliment) - Channel (Not Used)
Terminal #8	B - Channel
Terminal #9	A' (Compliment) - Channel (Not Used)
Terminal #10	A - Channel
Terminal #11	Z' (Compliment) - Home Channel (Not Used)
Terminal #12	Z - Home Channel

NOTES:

1. Encoder wiring shown is for C.W. rotation of *Posidyne* output shaft. If C.C.W. rotation is desired reverse "A" and "B" encoder signals or change the Encoder Sensor setting through the menu interface.
2. Encoder Channel "A" must lead Channel "B". Slowly rotate the *Posidyne* output shaft in a the proper direction and check to be sure the Position Display counts up. If they don't, change the Encoder Sensor setting through the menu interface.

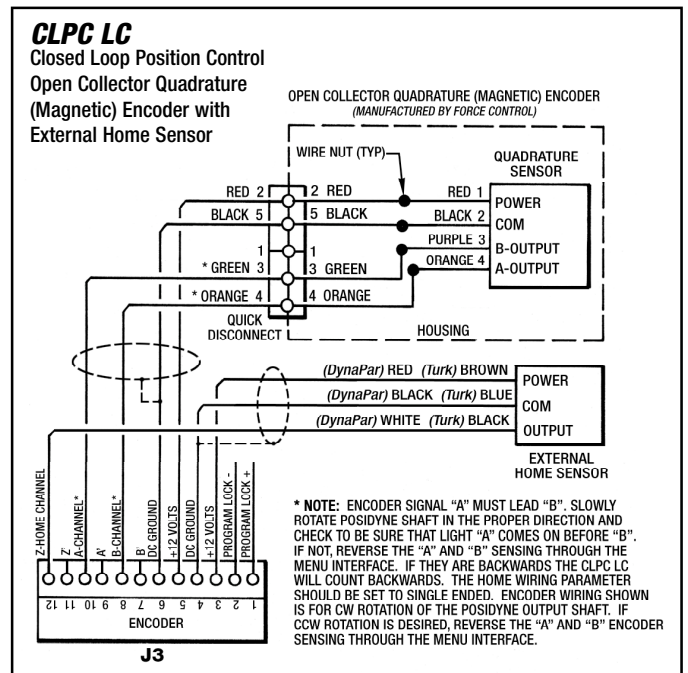

Figure 2 - Wiring Diagram - Terminal Block #J3 (With External Home Sensor)