



502-CB-210-01

# SERVICE MANUAL and REPAIR PARTS

FOR

***Posistop<sup>®</sup> MB-210, MB-210L  
MB-250, MB-280 & MB-320  
COUPLER BRAKES***

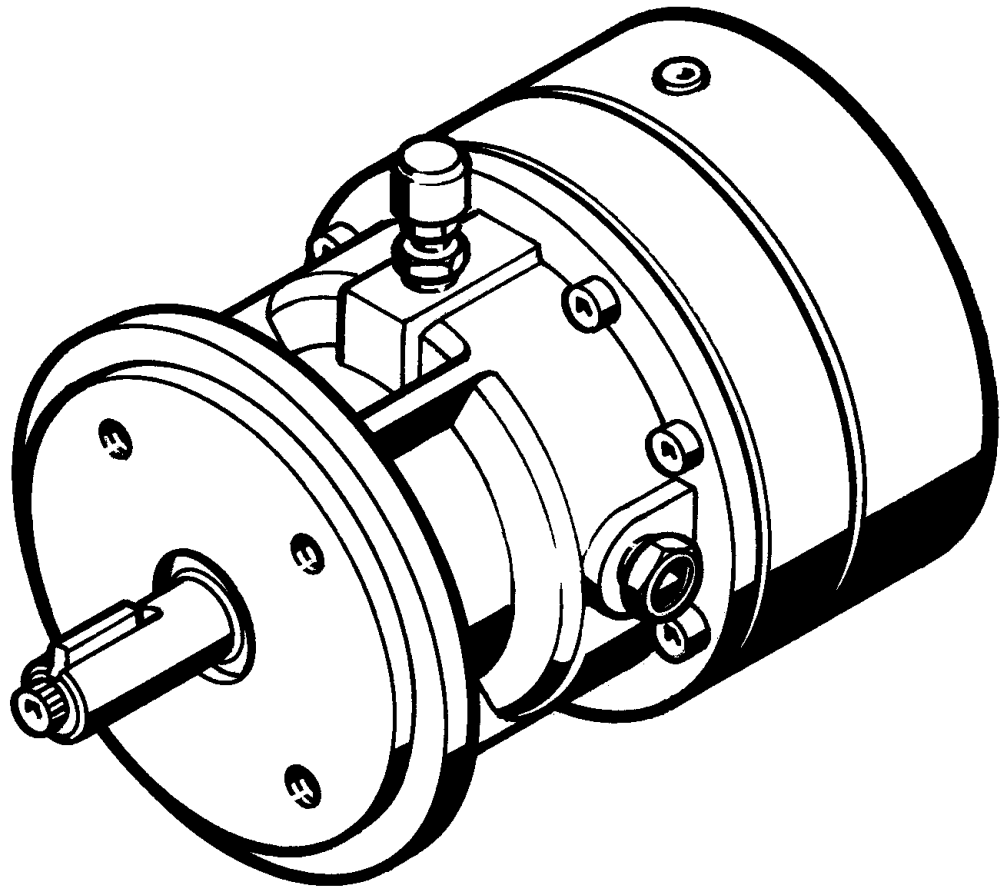

**WARNING - Read this manual before any  
installation, maintenance or operation.**



**FORCE CONTROL INDUSTRIES, INC.**

**MANUFACTURERS OF MECHANICAL AND  
ELECTRICAL POWER TRANSMISSION EQUIPMENT**



**INDUSTRIAL MAGZA<sup>®</sup>  
DIST. AUTORIZADO**

MEX (55) 53 63 23 31  
QRO (442) 1 95 72 60

MTY (81) 83 54 10 18  
ventas@industrialmagza.com

---

---

## Limited Warranty

Force Control Industries, Inc. ("Force Control") warrants its products to be free from defects in material and workmanship under normal and proper use for a period of one year from the date of shipment. Any products purchased from Force Control that upon inspection at Force Control's factory prove to be defective as a result of normal use during the one year period will be repaired or replaced (at Force Controls' option) without any charge for parts or labor. This limited warranty shall be void in regard to (1) any product or part thereof which has been altered or repaired by a buyer without Force Control's previous written consent or (2) any product or part thereof that has been subjected to unusual electrical, physical or mechanical stress, or upon which the original identification marks have been removed or altered. Transportation charges for shipping any product or part thereof that the buyer claims is covered by this limited warranty shall be paid by the buyer. If Force Control determines that any product or part thereof should be repaired or replaced under the terms of this limited warranty it will pay for shipping the repaired or replaced product or part thereof back to the buyer. EXCEPT FOR THE EXPRESS WARRANTY SET OUT ABOVE, FORCE CONTROL DOES NOT GRANT ANY WARRANTIES EITHER EXPRESSED OR IMPLIED, INCLUDING IMPLIED WARRANTIES OF MERCHANTABILITY OR FITNESS FOR USE. The warranty obligation set forth above is in lieu of all obligations or liabilities of Force Control for any damages. Force Control specifically shall not be liable for any costs incurred by the buyer in disconnecting or re-installing any product or part thereof repaired or replace under the limited warranty set out above. FORCE CONTROL EXPRESSLY EXCLUDES ALL LIABILITY FOR ANY INDIRECT OR CONSEQUENTIAL DAMAGES THE BUYER MAY SUSTAIN IN CONNECTION WITH THE DELIVERY, USE, OR PERFORMANCE OF FORCE CONTROL PRODUCTS. Under no circumstances shall any liability for which Force Control is held responsible exceed the selling price to the buyer of the Force Control products that are proven to be defective. This limited warranty may be modified only in writing signed by a duly authorized officer of the company. This limited warranty applies exclusively to Force Control products; warranties for motors and gear reducers and other component parts may be provided by their respective manufactures. Any legal action for breach of any Force Control warranty must be commenced within one year of the date on which the breach is or should have been discovered.

A Return Goods Authorization (RGA) number must be obtained from the factory and clearly marked on the outside of the package before any equipment will be accepted for warranty work. Force Control will pay the shipping costs of returning the owner parts that are covered by warranty.

Force Control believes that the information in this document is accurate. The document has been carefully reviewed for technical accuracy. In the event that technical or typographical errors exist, Force Control reserves the right to make changes to subsequent editions of this document without prior notice to holders of this edition. The reader should consult Force Control if errors are suspected. In no event shall Force Control be liable for any damages arising out of or related to this document or the information contained in it.

**FORCE CONTROL INDUSTRIES, INC.**



MEX (55) 53 63 23 31 MTY (81) 83 54 10 18  
QRO (442) 1 95 72 60 [ventas@industrialmagza.com](mailto:ventas@industrialmagza.com)



# Table of Contents

## Section 1 - DESCRIPTION AND OPERATION

1-1 The Oil Shear Principle .....	1
1-2 Typical Applications .....	1
1-3 Description .....	1
1-4 Features and Benefits .....	1
1-5 Coupler Brake Operation .....	2

## Section 2 - SPECIFICATIONS

2-1 Dimensional Specifications .....	3
2-2 Brake Stack Assembly Configurations (Horizontal Mounting) .....	4
2-3 Brake Stack Assembly Configurations (Vertical Mounting) .....	4
2-4 Operating Specifications .....	5

## Section 3 - INSTALLATION

3-1 Installation for Size MB-210 & MB-210L Brake .....	6
3-2 Installation for Size MB-250 Brake .....	8
3-3 Installation for Size MB-280 & MB-320 Brake .....	9
3-4 Mounting Motor and Brake to Gear Reducer .....	10
3-5 Final Installation .....	10
<i>A. Lubrication</i> .....	10
<i>B. Pneumatic</i> .....	10
3-6 Vertical Installation .....	10

## Section 4 - LUBRICATION

4-1 Checking the Oil Level .....	11
4-2 Changing the Oil .....	11
4-3 Horizontal Brakes .....	11
4-4 Fluid Capacity .....	11
4-5 Type of Oil .....	11
4-6 MB-210 & MB-210L Vertical Down Brake .....	12

## Section 5 - Operational Checks

5-1 Operational Checks .....	13
------------------------------	----

## Section 6 - TROUBLE SHOOTING

6-1 Trouble Shooting Chart .....	14
6-2 Measuring Brake Stack Height .....	15

## Section 7 - DISASSEMBLY

7-1 General Disassembly Information .....	16
7-2 Removing Coupler Brake & Drive Motor From Gear Reducer .....	16
7-3 Removing End Housing (#9) for Access to the Brake Stack .....	16
7-4 Removing the Hub (#2) .....	17
7-5 Hub (#2) Disassembly .....	18
<i>A. Removing Wear Sleeves (#32) and (#86)</i> .....	18
<i>B. Removing Bearing (#20)</i> .....	18
7-6 Removing Piston Housing (#10) to Replace Piston Seals .....	18
<i>A. Posistop MB-210 &amp; MB-210L Only</i> .....	18
<i>B. Posistop MB-250, 280 and 320</i> .....	19

## Section 8 - CLEANING & INSPECTION

8-1 Cleaning & Inspection .....	20
8-2 Repair and Replacement .....	20

# Table of Contents (Concluded)

## Section 9 - REASSEMBLY

9-1 General Reassembly Instructions .....	21
9-2 Mounting Screws and Torque Requirements .....	21
9-3 Installing Oil Seals .....	21
9-4 Installing Housing (#8) to Drive Motor .....	21
A. MB-210 & MB-210L Coupler Brake .....	21
B. MB-250, 280 and 320 Coupler Brake .....	21
9-5 Piston (#3) and Piston Housing (#10) Reassembly .....	21
A. MB-210 & MB-210L Coupler Brake .....	21
B. MB-250, 280 and 320 Coupler Brake .....	22
9-6 Hub (#2) Reassembly .....	23
A. Installing Wear Sleeve (#32) .....	23
B. Installing Bearing (#20) .....	23
C. Installing Wear Sleeve (#86) .....	23
9-7 Installing Hub (#2) Into Brake .....	24
A. MB-210 & MB-210L Coupler Brake .....	24
B. MB-250 and 280 Coupler Brake .....	24
C. MB-320 Coupler Brake .....	25
9-8 Installing Piston Housing Assembly (Sizes MB-250, 280 & 320 Only) .....	25
9-9 Installing the Brake Stack .....	25
A. Assembly Tips .....	25
B. Horizontal Mounted Coupler Brakes .....	25
C. Vertical Mounted Coupler Brakes .....	25
9-10 Installing End Housing (#9) to the Brake Assembly .....	26
9-11 Final Hub Alignment .....	26
9-12 Final Reassembly .....	27
9-13 Mounting Motor and Brake to Gear Reducer .....	27

## Section 10 - ORDERING REPLACEMENT PARTS

10-1 General Information .....	28
10-2 Factory Rebuild Service .....	28
10-3 Ordering Replacement Parts .....	28
10-4 Name Plate Information .....	28
Model Number Information .....	29
Repair Parts List for Figure 10.1 .....	30
Figure 10.1 - MB-210 & MB-210L Coupler Brake .....	31
Repair Parts List for Figure 10.2 .....	32
Figure 10.2 - MB-250, 280 and 320 Coupler Brake .....	33
Repair Parts List for Figure 10.3 .....	34
Figure 10.3 - Pneumatic Control Valve Mounting Kit .....	34
Dimensions for Wear Sleeve Assembly Tools .....	35

**FORCE CONTROL INDUSTRIES, INC.**



MEX (55) 53 63 23 31    MTY (81) 83 54 10 18  
QRO (442) 1 95 72 60    [ventas@industrialmagza.com](mailto:ventas@industrialmagza.com)

# Section 1

## DESCRIPTION AND OPERATION

### 1-1 THE OIL SHEAR PRINCIPLE

Conventional clutches and brakes depend on the friction between solid surfaces operating in air to transmit torque. Friction does the job, but produces a great amount of Heat and Wear, causing an increase in replacement parts, breakdown and maintenance time.

**OIL SHEAR TECHNOLOGY** was pioneered by **Force Control Industries, Inc.** in 1959 and resulted in one of the most energy efficient Clutch/Brake or Variable Drive Systems available today.

In 1970 **Force Control** introduced an **integral oil pump**, which requires no additional parts. This oil pump forces a positive oil feed from the center of the brake disc stack to “**Float**” the friction surfaces in a continuously circulating bath of oil.

The oil molecules tend to cling to each other and also to the friction surfaces. As moving and stationary parts are brought together, a thin but positive film of oil is maintained between them and is controlled by the clamping pressure and grooves machined into the braking surfaces.

**Torque** is transmitted from one surface to the other through the viscous shear of the oil film. The braking surfaces are protected by this oil film, which reduces wear and effectively transmits heat away from the braking surfaces.

**...thus brake wear is greatly reduced along with all routine maintenance common to conventional dry friction motor brakes.**

**AN OIL CHANGE EVERY 6 MONTHS IS ALL THAT IS REQUIRED FOR NORMAL MAINTENANCE.**

### 1-2 TYPICAL APPLICATIONS

(See Figure 1.1)

The **Posistop MB-210, 210L, 250, 280 and 320 Coupler Brakes** can be applied where cycle rates are too low to justify a Clutch/Brake (roughly less than 10 CPM), or in applications where the motor must reverse. Common applications include Palletizers (apron or slip plate, flight or push bar, roller bed conveyor), Indexing Conveyors, Shrink Wrappers, Package Handling Equipment, General Material Handling Equipment and Tire Manufacturing Equipment.

*Typical Drive Assembly is shown in Figure 1.1.*

### 1-3 DESCRIPTION

(See Figures 1.1 and 1.2 )

The **Posistop Coupler Brake** is a compact motor brake that transmits torque by shearing fluid between multiple friction surfaces. The fluid cools and constantly lubricates the

friction surfaces for improved performance and longer service life. It also reduces engagement shock that results when dry friction brakes are used.

This brake is designed for indexing applications utilizing a standard NEMA C-Face register on both ends which allows the brake to be mounted between a C-Face Drive Motor and a C-Face Speed Reducer.

**A complete package can be furnished including the Drive Motor, Coupler Brake and Speed Reducer. Contact Force Control for selecting the proper size components for long life cycling applications.**

The multiple brake disc stack delivers high torque in a low inertia package. The **Posistop Coupler Brakes** listed in this manual are rated at a maximum of 20 Ft. Lbs. to 450 Ft. Lbs of torque.

### 1-4 FEATURES AND BENEFITS

**The most important Feature and Benefit is the fact that it will reduce maintenance time and provide a very long service life.**

- Low inertia, multiple disc oil shear brake for long life, high cycle rates and high thermal loads
- Keyless Collet is a positive self-locking element with high torque transmitting capabilities. Standard sizes range from 7/8" Dia. to 1-7/8" Dia.
- Totally enclosed design prevents contamination and corrosion.
- Spring set brake with air release. (Automatic braking if electrical or pneumatic power is interrupted.)
- Standard NEMA C-Face mounting. AC or DC motor connections for 182T to 286T and 213U to 326U frame motors.

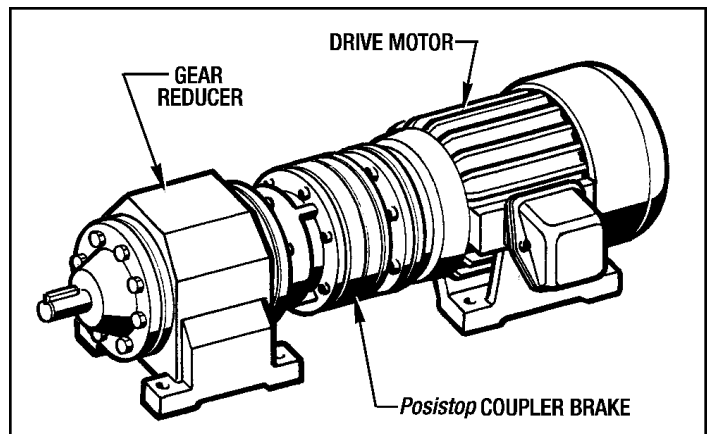

Figure 1.1 - Posistop Coupler Brake Drive Package

**FORCE CONTROL INDUSTRIES, INC.**



MEX (55) 53 63 23 31 MTY (81) 83 54 10 18  
QRO (442) 1 95 72 60 ventas@industrialmagza.com

- Multiple surface brake stack distributes the braking torque along the whole hub rather than on a single braking surface, reducing the heat and wear on each braking surface.
- Internal integral oil pump maintains the **Oil Shear Principle** without external pumping devices.
- 20 Ft. Lbs. to 450 Ft. Lbs. braking torque.  
(Contact Force Control for other torque requirements.)
- Vertical up, vertical down and horizontal mounting.
- Standard output shafts from 1-1/8" dia. to 1-7/8" dia.
- Applications for customer's output shaft include coupled or quill connections.

## 1-5 COUPLER BRAKE OPERATION

The Cross Section in *Figure 1.2* shows the brake in the normally spring-set braked position.

**To run** - The Control Valve Solenoid is energized which directs compressed air into the piston chamber which moves the piston to disengage the brake stack, allowing the drive motor to rotate freely.

**To Stop** - The Control Valve Solenoid is de-energized which exhausts the air from the piston chamber. The Piston, which is spring loaded, returns to the braking position and stops the drive motor.

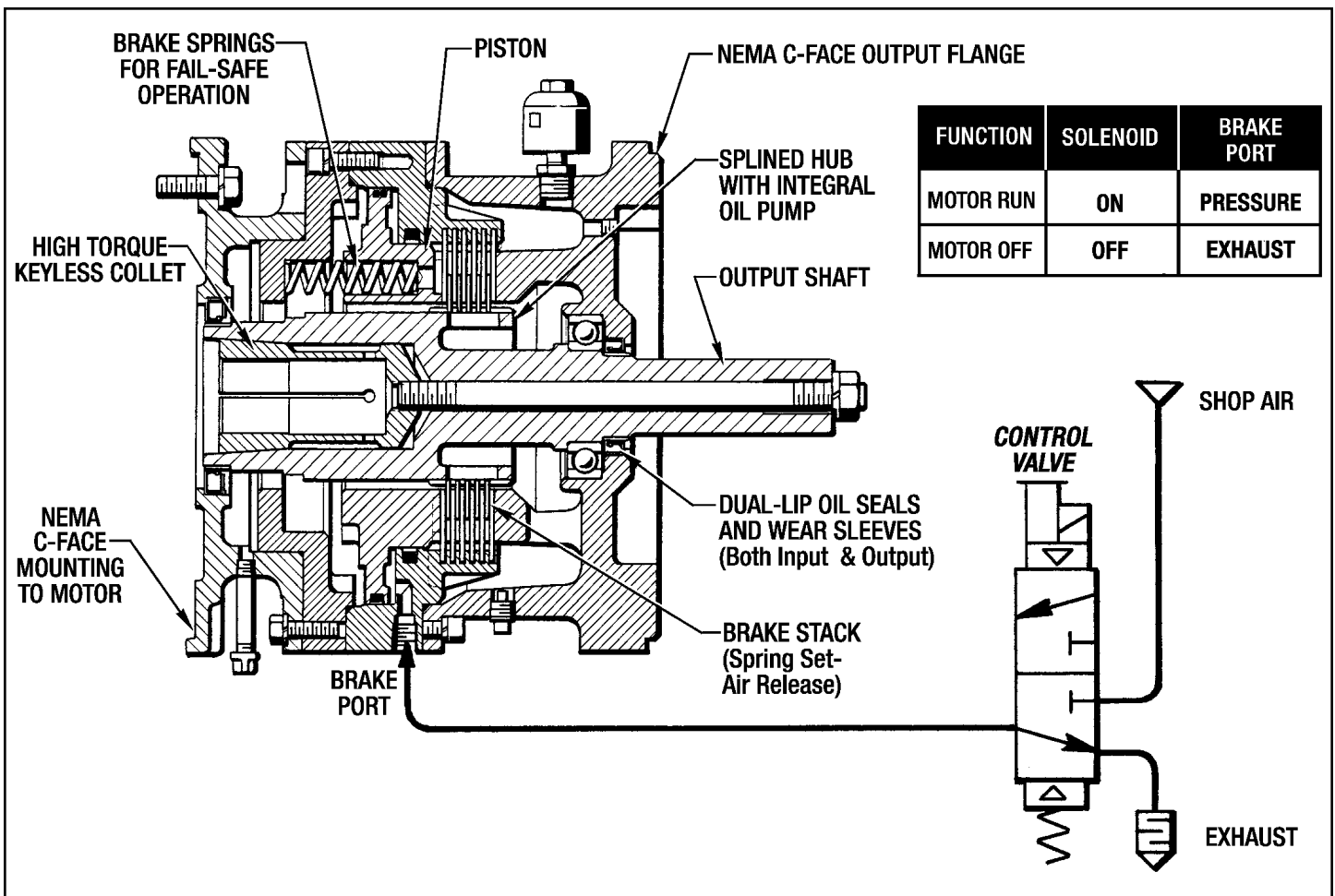

Figure 1.2 - Posistop Coupler Brake Operation

# Section 2 SPECIFICATIONS

## 2-1 DIMENSIONAL SPECIFICATIONS

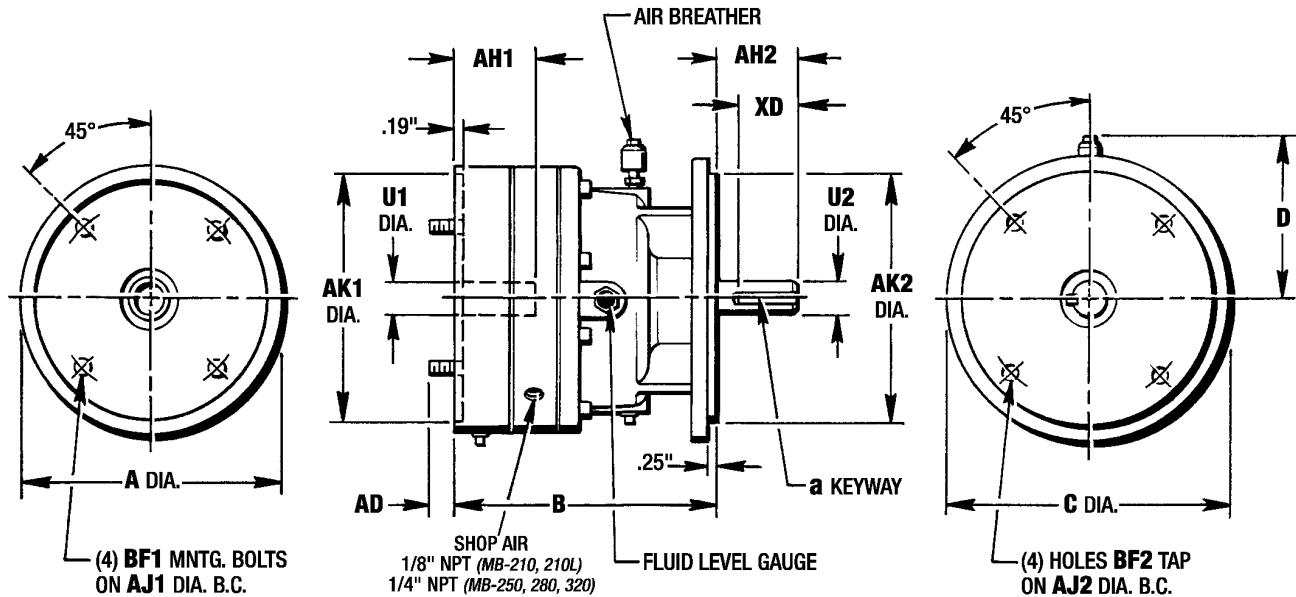

Figure 2.1 - Posistop Coupler Brakes Dimensions

BRAKE SIZE	MOTOR FRAME	INPUT MOUNTING FLANGE						OUTPUT MOUNTING FLANGE							
		U1	AH1		AK	BF1	AJ1	AD	U2	AH2	AK2	a	XD	BF2	AJ2
MIN	MAX														
210	182T	1.125	1.75	2.75	8.50	1/2-13	7.25	.50	1.125	2.63	8.50	1/4 x 1/8	1.75	1/2-13	7.25
	184T									2.75			2.00		
	213U														
	215U														
210L and 250	213T	1.375	(210L) 2.50	(210L) 3.50	8.50	1/2-13	7.25	.50	1.375	3.13	8.50	5/16 x 5/32	2.38	1/2-13	7.25
	215T		(250) 2.00	(250) 4.00						3.50					
	254U														
	256U														
250	254T	1.625	2.00	4.00	8.50	1/2-13	7.25	.75	1.625	3.75	8.50	3/8 x 3/16	2.88	1/2-13	7.25
	256T														
280	284U	1.625	2.25	4.00	10.50	1/2-13	9.00	.75	1.625	4.63	10.50	3/8 x 3/16	3.75	1/2-13	9.00
	286U								1.875	4.38					
	284T														
	286T														
320	324U	1.875	2.50	4.63	12.50	5/8-11	11.00	.88	1.875	5.38	12.50	1/2 x 1/4	4.25	5/8-11	11.00
	326U														

All dimensions are subject to change without notice.

Certified Installation Drawings are available upon request.

All dimensions are given in inches.

- Consult factory for dimensions.

BRAKE SIZE	OVERALL DIMENSIONS			
	A	B	C	D
210	8.81	7.44	9.75	6.69
210L	8.81	8.19	9.75	6.69
250	9.25	10.38	11.00	6.94
280	11.00	10.38	11.00	6.94
320	12.88		12.88	8.25

**FORCE CONTROL INDUSTRIES, INC.**



MEX (55) 53 63 23 31 MTY (81) 83 54 10 18  
 QRO (442) 1 95 72 60 ventas@industrialmagza.com

## 2-2 BRAKE STACK ASSEMBLY CONFIGURATIONS (HORIZONTAL MOUNTING)

Given below are the Brake Stack Assembly Configurations for Horizontal Mounted *Posistop* Coupler Brake and for each designated Torque Requirement.

### A. *Posistop* MB-210 and MB-210L Coupler Brake

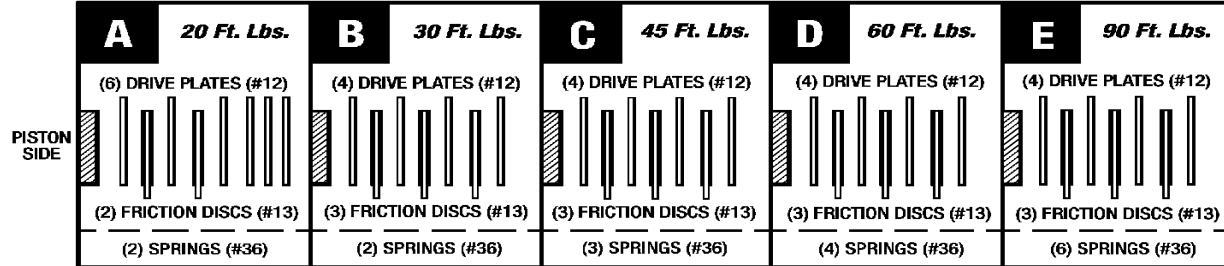

### B. *Posistop* MB-250 and MB-280 Coupler Brake

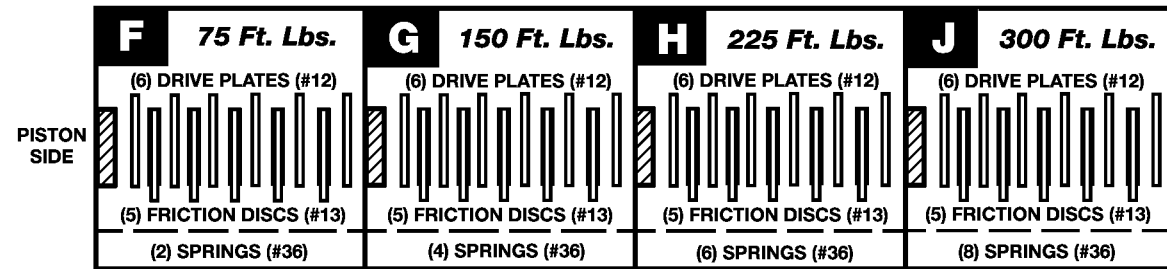

### C. *Posistop* MB-320 Coupler Brake

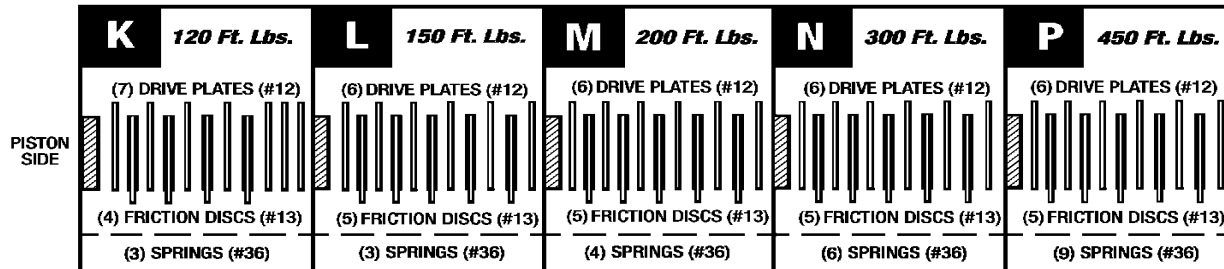

## 2-3 BRAKE STACK ASSEMBLY CONFIGURATIONS (VERTICAL MOUNTING)

Given below are the Brake Stack Assembly Configurations for Vertical Mounted *Posistop* Coupler Brake and for each designated Torque Requirement

### A. *Posistop* MB-210 and MB-210L Coupler Brake

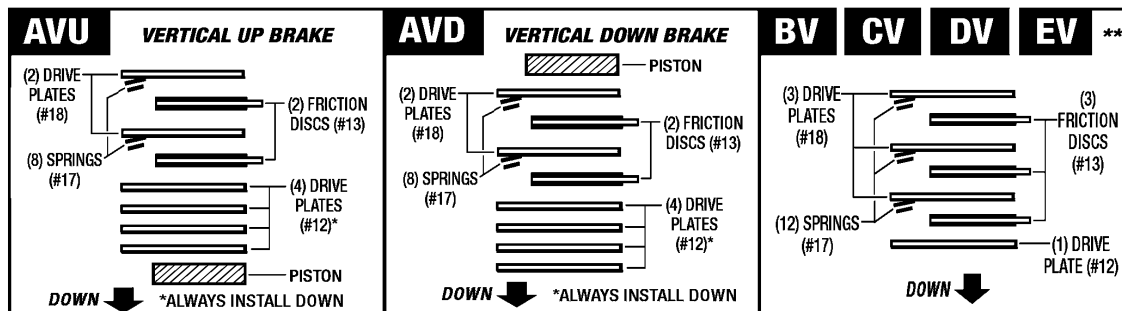

NOTES - Torque Ratings and Spring (#36) Quantity are the same as Horizontal Mounted Brakes.

\*\* Stack Configuration is the same for Vertical Up or Down.

**(VERTICAL MOUNTING - Continued)**

**B. Posistop MB-250 and MB-280 Coupler Brake**

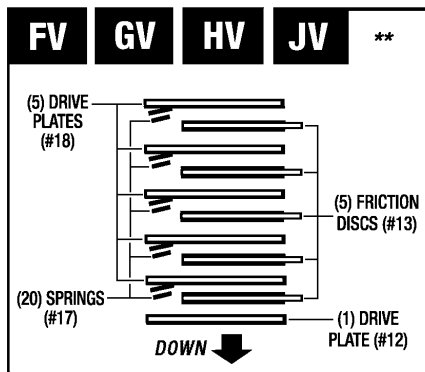

**NOTE** - Torque Ratings and Spring (#36) Quantity are the same as Horizontal Mounted Brakes.

\*\* Stack Configuration is the same for Vertical Up or Down.

**C. Posistop MB-320 Coupler Brake**

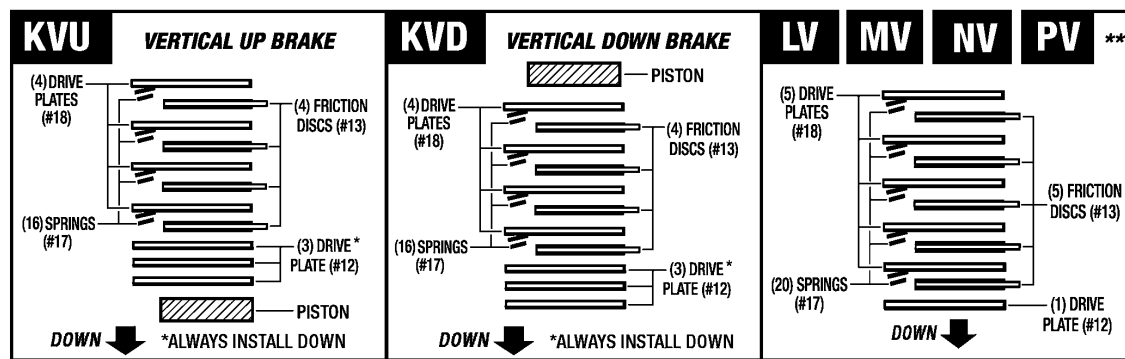

**NOTE** - Torque Ratings and Spring (#36) Quantity are the same as Horizontal Mounted Brakes.

\*\* Stack Configuration is the same for Vertical Up or Down.

**2-4 OPERATING SPECIFICATIONS**

BRAKE MODEL NUMBER	TORQUE ASSEMBLY CONFIG. <i>(See Above)</i>	NOMINAL STATIC TORQUE <i>(Ft. Lb.)</i>	NOMINAL DYNAMIC TORQUE <i>(Ft. Lb.)</i>	MIN. PR. TO RELEASE <i>(PSI)</i>	THERMAL RATING <i>(HP Sec/Min)</i>	CYCLIC WK <sup>2</sup> <i>(Ft. Lb.<sup>2</sup>)</i>	PISTON VOLUME <i>(Cu. In.)</i>
MB-210 MB-210L	A & AV	20	17	20	25	.034	3
	B & BV	30	26	20			
	C & CV	45	39	28			
	D & DV	60	52	35			
	E & EV	90	78	51			
MB-250 MB-280	F & FV	75	65	18	45	.215	5
	G & GV	150	130	32			
	H & HV	225	194	46			
	J & JV	300	259	60			
MB-320	K & KV	* 120	104	23	70	.215	6
	L & LV	* 150	130	23			
	M & MV	* 200	173	30			
	N & NV	** 300	259	42			
	P & PV	** 450	388	62			

\* Uses a 5-1/4" O.D. Friction Disc.

\*\* Uses a 6-1/4" O.D. Friction Disc.

Maximum Speed-1800 RPM

Contact the Force Control Factory or your Force Control Representative for additional information on different Torque Ratings and Assembly Configurations not listed in this manual.

## Section 3 INSTALLATION

This **INSTALLATION PROCEDURE** covers the Installation of the Brake Unit to the Drive Motor and to the Gear Reducer.

**CAUTION - The following precautions must be taken if the installation of this Posistop Brake is to be a retro-fit for an existing application. Before attempting installation, open the motor disconnect, shut off the control electrical supply and shut off the air supply. Lock them out to avoid any possibility of personal injury.**

All brake units are shipped dry so fluid will have to be added after installation and before operation.

Only the MB-210 MB-210L and MB-250 will have to be partially dis- assembled to install them to the drive motor. The Collet (#110) and the Hub (#2) is also shipped separate for the MB-210, MB-210L & MB-250. The MB-280 and MB-320 can be installed as a complete assembly to the drive motor.

Special Installation Tools must also be used to properly install these brake units to the drive motor. Dimensions and Material Specs. are given in *Figure 3.1* below if you prefer to make your own tool, otherwise they can be ordered from **Force Control** with the following part numbers. Dimensions and Specifications for the other Threaded Rod "A" & Jack Bolt are given in *Figure 7.4*

Size MB-210 & 210L.....Part No. 601-13-047  
 Sizes MB-250, 280 & 320.....Part No. 601-18-002

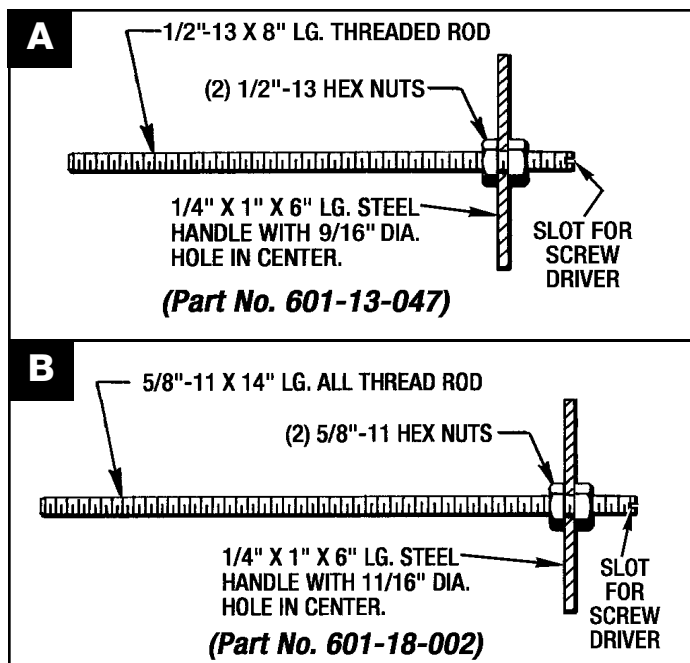

Figure 3.1 - Special Installation Tool

### (For All Sizes)

First check the motor shaft, pilot diameter and mounting face to make sure they are clean and free of any nicks or burrs. Clean-up and de-burr if necessary.

**IMPORTANT - Do not use any Molybdenum Disulfide "MOLYKOTE" or any other similar lubricant on the motor shaft.** The collet locking element is keyless and depends on friction to transmit torque from the brake to the motor shaft.

### 3-1 INSTALLATION FOR SIZE MB-210, 210L BRAKE

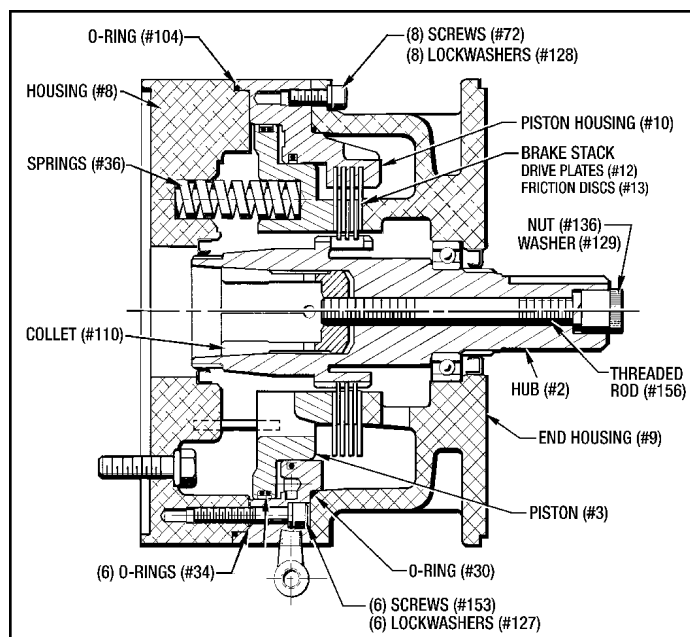

Figure 3.2 - MB-210 and MB-210L Assembly

The Brake Unit first has to be partially disassembled to install it on the motor. (See Figure 3.2 above.)

1. Remove the End Housing (#9) from the Piston Housing (#10) by taking out the (8) Screws (#72) and (8) Lockwashers (#128).

**NOTE -** Be careful not to lose or damage the O-Ring (#30) located on the piston housing mounting register.

2. Take the Brake Stack out of the brake. **Be sure to keep the Friction Discs (#13) and Drive Plates (#12) in the same order as removed.**
3. Remove the Piston Housing (#10) and Piston (#3) Assembly by taking out the (6) Screws (#153) and (6) Lockwashers (#177). Be careful not to lose or damage the (6) small O-Rings (#34) and the larger O-Ring (#104).

**CAUTION - This Piston Assembly is under spring pressure so evenly back out the (6) attaching Screws (#153). Also make note of or a little sketch of the quantity and placement of the Brake Springs (#36). Also see Figure 9.2**

- Attach the Housing (#8) to the motor face with (4) Soc. Hd. Screws (#150). Use (4) Dyna-Seals (#126) under the cap screw heads. Use Blue Loctite #242 on the screws. **Torque to 60 Lb. Ft.**

Place the Collet (#110) on to the motor shaft as far as it will go. (See Figure 3.3.)

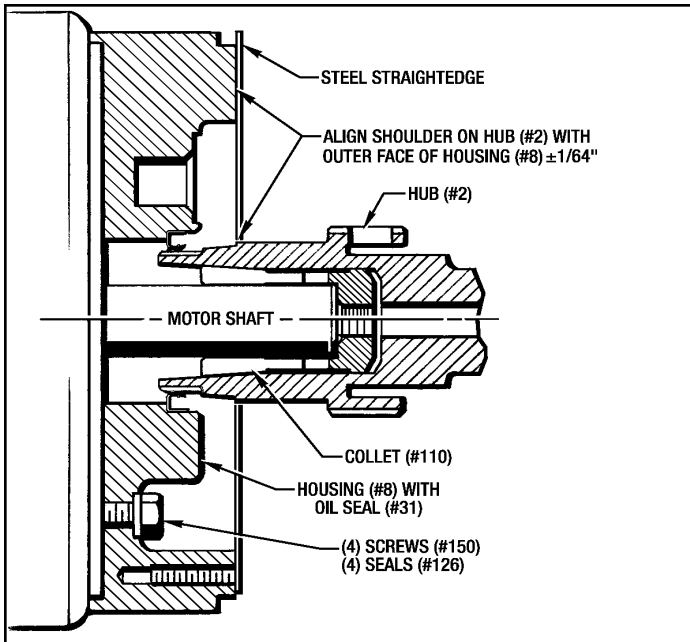

Figure 3.3 - Mounting Housing and Collet

- Lubricate the lip of the Oil Seal (#31) with a little White Grease (or equivalent).
- Slide the Hub (#2) over the Collet (#110) and into the Oil Seal (#31) as shown in Figure 3.3. If the Hub has an alignment shoulder, then align it with the outer face of Housing (#8) within  $\pm 1/64$ ". If the Hub doesn't have the shoulder then use the procedure in Step #10 & shown in Figure 3.4.

**CAUTION - Be very careful not to damage the lip of the Oil Seal (#31) when inserting the Hub (#2).**

- Place the Springs (#36) back into the appropriate pockets. You can use white grease to hold the springs in place. (See Figures 3.4 and 9.2.)
- If the O-Ring (#104) was removed from the Housing (#8) then re-install it back on with a little White Grease to lubricate it. (See Figure 3.4.)
- Attach the Piston Housing (#8) and Piston (#3) Assembly with (6) Screws (#153) and (6) Lockwashers

(#127). Align the Pin (#158) in the Piston with the hole in the Housing **Torque to 14 Lb. Ft.** (See Figure 3.4.)

**NOTE -** Tighten these (6) Screws (#153) down in an even manner to compress the Brake Springs (#36) properly.

- Position the Hub (#2) so the end of the spline is **.563" (9/16")** from the Piston Face. (See Figure 3.4)

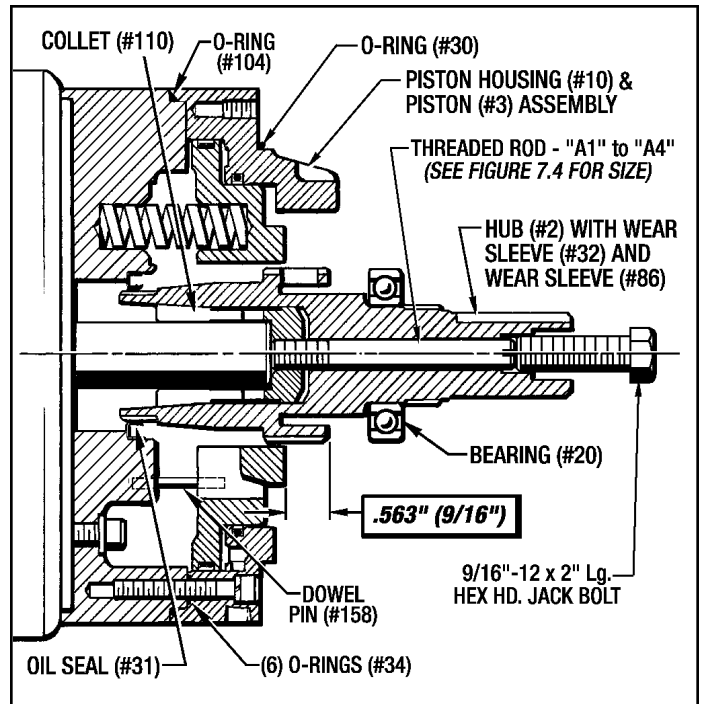

Figure 3.4 - Installing Piston Housing Assembly & Hub

- Install the correct Threaded Rod "A" into the Collet (#110) approx. 4 or 5 turns. **Hand tighten** the Jack Bolt into the end of the Hub (#2) just until it makes contact with the Threaded Rod "A". **Do not tighten any further.** (See Figure 3.4 above.)
  - Lubricate the other O-Ring (#30) with a little White Grease and install it on the Piston Housing (#10). (See Figure 3.4.)
  - Apply 60 PSI air pressure to the Brake Port to push the piston back so there will be more room on the spline and brake lugs for the Brake Stack.
  - Install the Brake Stack on the spline of the Hub (#2) and the lugs of the Piston Housing (#10). (See Section 9-9 for Assembly Tips and Procedure.)
- IMPORTANT - Make sure the brake stack is installed in exactly the same order as you removed them.**
- Lubricate the lip of the Oil Seal (#35) located in the End Housing (#8) with a little White Grease.

16. Install the End Housing (#9) to the Piston Housing (#10) with (8) Screws (#72) and (8) Lockwashers (#128) and finalize the Position Alignment of the Hub (#2) with the **Same Procedure described in Section 9-10 & 9-11.**

### 3-2 INSTALLATION FOR SIZE MB-250 BRAKE

This MB-250 Brake is similar to the MB-210 & MB-210L in that it also has to be partially disassembled to install it to the drive motor.

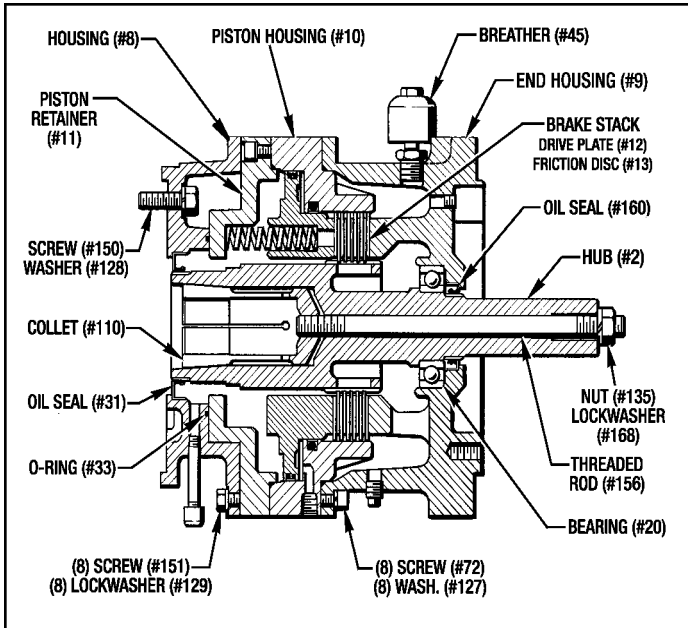

Figure 3.5 - MB-250 Motor Brake Assembly

1. Remove the Housing (#8) from the Brake Assembly by removing the (8) Screws (#151) and (8) Lockwashers (#129).
  2. Attach this Housing (#8) to the mounting face of the Drive Motor with (4) Screws (#150) and (4) Lockwashers (#128). **Torque to 60 Lb. Ft.** (See Figure 3.6)
- CAUTION - Be careful not to lose or damage the O-Ring (#33) located in the groove of the End Housing (#8).**
3. Place the Collet (#110) on the motor shaft as far as it will go. (See Figure 3.6)
  4. Lubricate the lip of the Oil Seal (#31) located in the End Housing (#8) with a little White Grease or equivalent.
  5. Slide the Hub (#2) over the Collet (#110) and into the lip of the Oil Seal (#31).
- CAUTION - Be careful not to damage the lip of the Oil Seal.**
6. Using a steel straight edge, align the 2nd. shoulder of the Hub (#2) with the outer face of End Housing (#8) as shown in Figure 3.6..

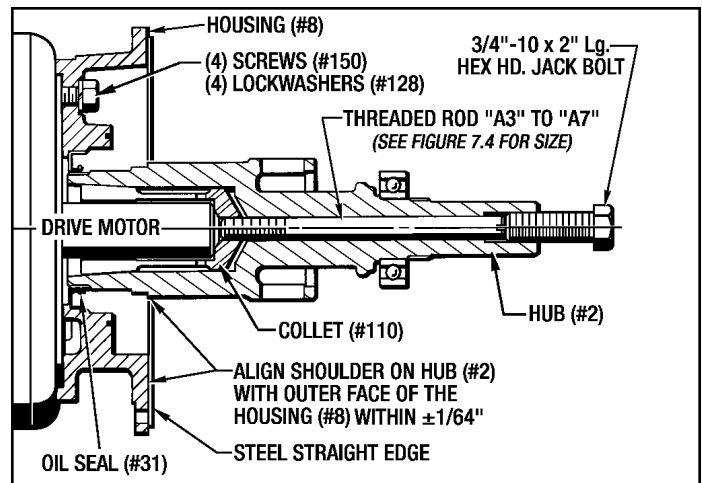

Figure 3.6 - Installing Housing, Collet and Hub to motor

7. Install the correct Threaded Rod "A" into the Collet (#110) approx. 4 or 5 turns. **Hand tighten** the Jack Bolt into the end of the Hub (#2) just until it makes contact with the Threaded Rod "A". **Do not tighten any further.** (See Figure 3-6.)
  8. Remove the End Housing (#9) from the Piston Housing (#10) by taking out the (8) Screws (#72) and (8) Lockwashers (#127).
  9. Remove the complete brake stack from the Piston Housing (#10) lugs.
- IMPORTANT - Keep the brake stack in the same order as you remove them.**
10. Lubricate the O-Ring (#33) with a little White Grease.
  11. Attach the complete Piston Housing Assembly to the Housing (#8) with the (8) Screws (#151) and (8) Lockwashers (#129). **Torque to 25 Lb. Ft.**

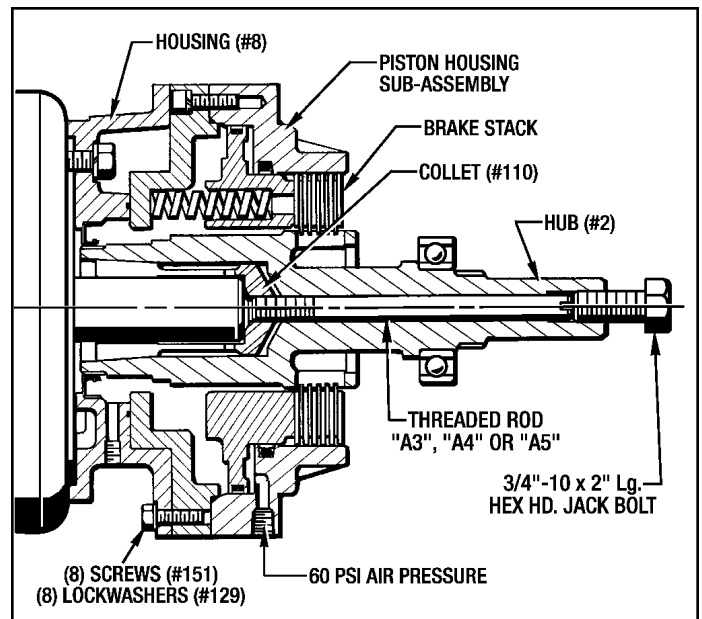

Figure 3.7 - Installing Piston Assembly & Brake Stack

12. Apply 60 PSI air pressure to the brake port as shown in *Figure 3.7*.

13. Install the Brake Stack on the spline of the Hub (#2) and the lugs of the Piston Housing (#10). **See Section 9-9 for Assembly Tips and Procedure.**

**IMPORTANT - Make sure the brake stack in installed in exactly the same order as you removed them.**

**NOTE -** The brake stack configuration shown on *Figure 3.7* is only an example. Your brake stack may be different as determined by your torque requirements.

14. Lubricate the lip of the Oil Seal (#160) located in the Output End Housing (#9) with a little White Grease, or equivalent

15. Install the End Housing (#9) to the Piston Housing (#10) with (8) Screws (#72) and (8) Lockwashers (#128) and finalize the Position Alignment of the Hub (#2) with the **Same Procedure as described in Section 9-10 & 9-11.**

### 3-3 INSTALLATION FOR SIZES MB-280 & MB-320

The MB-280 and MB-320 *Posistop* Coupler Motor Brake comes completely assembled and does not have to be disassembled to mount it to the Drive Motor. The Collet Locking Bolt (#156) and the Collet (#110) are the only parts that needs removed from the brake for installation.

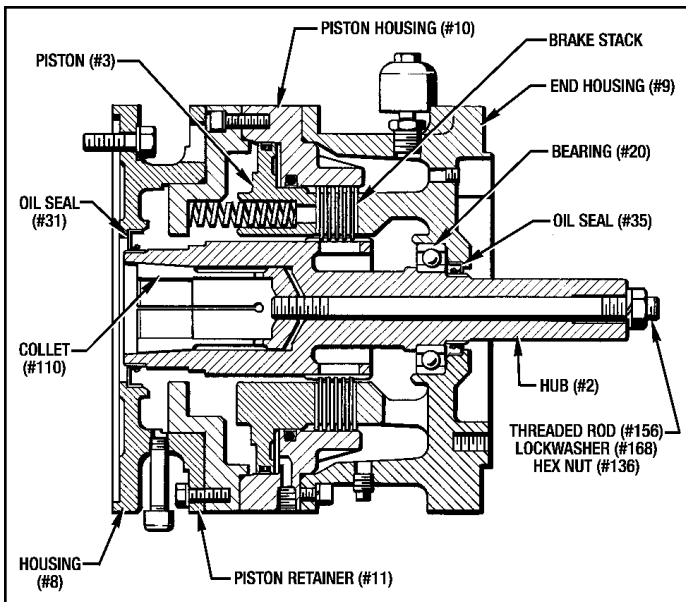

Figure 3.8 - MB-280 & MB-320 Coupler Brake

#### (Size MB-280 Motor Brake)

1. Remove the Collet (#110), Threaded Rod (#156), Lockwasher (#168) and Hex Nut (#135) from the Brake Assembly.
2. Place the Collet (#110) on the motor shaft as far as it will go.

3. Attach the Brake Assembly to the motor face with (4) Hex Hd. Screws (#150) and (4) Lockwashers (#128). **Torque to 60 Lb. Ft.**
4. Install the correct Threaded Rod "A" into the Collet (#110) approx. 4 or 5 turns. **Hand tighten** the Jack Bolt into the end of the Hub (#2) just until it makes contact with the Threaded Rod "A". **Do not tighten any further.** (See *Figure 3.9*.)

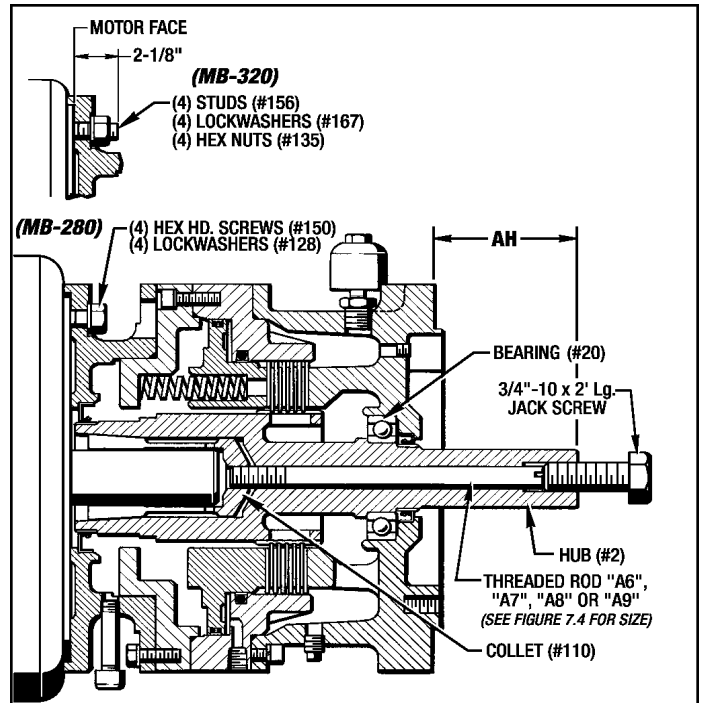

Figure 3.9 - Installing MB-280 and MB-320 Coupler Brakes

5. Measure and establish the correct dimension **AH** from the mounting surface of the output C-Face flange to the end of the Hub (#2) extended shaft. (See *Figure 3.9*) **Use the same procedure as described in Section 9-11 Final Hub Alignment.**

#### (Size MB-320 Motor Brake)

1. Remove the Collet (#110), Threaded Rod (#156), Lockwasher (#168) and Allen Nut (#136) from the Brake Assembly.
2. Place the Collet (#110) on the motor shaft as far as it will go.
3. Install the (4) Studs (#155) into the motor mounting holes with approximately 2-1/8" of thread exposed. Use Blue Loctite #242. (See *Figure 3.9*)
4. Attach the Brake Assembly with (4) Lockwashers (#128) and (4) Hex Nuts (#135). **Torque to 120 Lb. Ft.**
5. Install the correct Threaded Rod "A" into the Collet (#110) approx. 4 or 5 turns. **Hand tighten** the Jack Bolt into the end of the Hub (#2) just until it makes contact with the Threaded Rod "A". **Do not tighten any further.** (See *Figure 3.9*.)

6. Measure and establish the correct dimension **AH** from the mounting surface of the output C-Face flange to the end of the Hub (#2) extended shaft. (See Figure 3.9) Use the same procedure as described in Section 9-11 Final Hub Alignment.

### 3-4 MOUNTING MOTOR & BRAKE TO GEAR REDUCER

(See Figure 3.10)

It is recommended that you use a Coupling, rather than a hollow shaft to connect the Hub (#2) to the Gear Reducer.

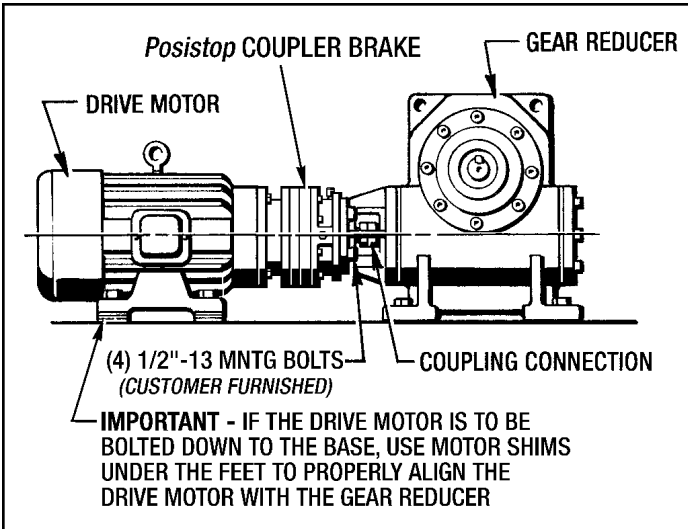

Figure 3.10 - Motor and Gear Reducer Alignment

1. Attach the Drive Motor and Brake Assembly to the Gear Box or Driven Machinery with the (4) 1/2"-13 Mounting Bolts (Customer Furnished). **Torque to 60 Lb. Ft.** Connect the coupling as per manufacturer's specifications.
2. If the Drive Motor is to be bolted down to the base, use motor shims under the feet to properly align the drive motor with the gear reducer as shown in Figure 3.10. **This is very important so the Coupler Brake will not be pulled down or pushed up.**
3. Connect shop air and electrical service to the Control Valve.

### 3-5 FINAL INSTALLATION FOR ALL SIZES

#### A. Lubrication

1. Make sure all drain plugs are installed and the Sight Gauge (#46) is clean and installed in the side of the brake.
2. Fill with oil as specified in Section 4 - Lubrication.

#### B. Pneumatic

The following schematic illustrates a typical Pneumatic Control System for a **Posistop Motor Brake**. Valving to be 3/8" NPT minimum and located as close to the brake as possible. 60 PSI is recommended for the brake release air pressure for all **Posistop Motor Brakes**.

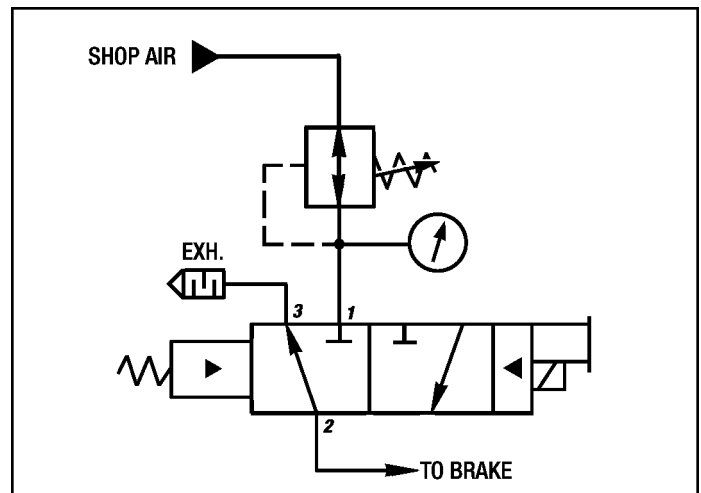

Figure 3.11 - Typical Pneumatic Control Diagram.

Contact Force Control for other minimum air pressures required for your **Posistop Motor Brakes**.

### 3-6 VERTICAL INSTALLATION

The Installation for the Vertical Mounted Coupler Brake is the same as described in this Section 3.

The following Figure 3.12 shows the mounting angles that determines a Vertical Up, Horizontal or Vertical Down Installation.

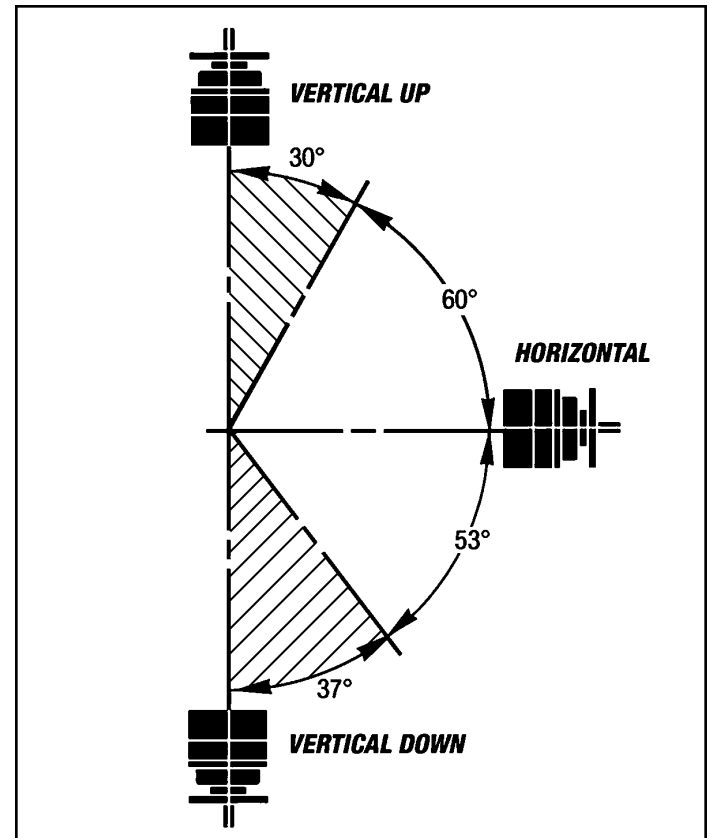

Figure 3.12 - Vertical Vs. Horizontal Installation

# Section 4 LUBRICATION

## 4-1 CHECKING THE OIL LEVEL

Check the oil level when the brake is initially installed and weekly thereafter or until experience dictates otherwise. Always check the oil with the brake stationary. (Not Running). The oil level is as shown in *Figure 4.1 & 4.2*.

## 4-2 CHANGING THE OIL (General Information)

**IMPORTANT - Always open the disconnects to the drive motor and lock them out before changing the oil.**

*Change the oil in your brake every 6 months or when the color of the oil starts to darken.*

**CAUTION - Do not overfill the brake. Excess oil will cause the brake to overheat.**

### NOTES:

1. The oil should be changed more frequently when used in harsh environments or high cyclic applications.
2. The Sight Gauge (#46) and Air Breather (#45) should always be removed and cleaned when the oil is changed.

## 4-3 CHANGING THE OIL (Horizontal Brakes)

(See *Figure 4.1*)

### A. Draining The Oil

#### (MB-210 and MB-210L Coupler Brake)

1. Remove the (2) Sq. Hd. Pipe Plugs (#74) from the bottom of the brake and drain all the oil into a suitable container. Save or discard as condition warrants. Replace the (2) Sq. Hd. Pipe Plugs (#74).

#### (MB-250, 280 and 320 Coupler Brake)

1. Remove the Sq. Hd. Pipe Plug (#74) and the Pipe Cap (#67) from the bottom of the brake and drain all the oil into a suitable container. Save or discard as condition warrants. Replace the Sq. Hd. Pipe Plug (#74) and the Pipe Cap (#67).

### B. Filling With Oil

1. Remove the Air Breather (#45) and the Reducer

Bushing (#76) from the top of the End Housing (#9) and fill the brake with fresh oil to the center of the Sight Gauge (#46) as shown in *Figure 4.1*.

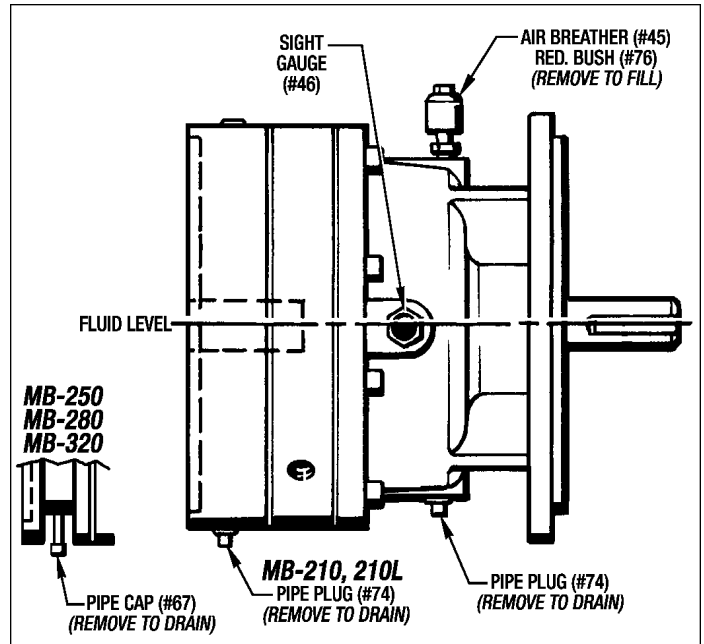

Figure 4.1 - Horizontal Brake Lubrication

## 4-4 FLUID CAPACITY

The Fluid capacity for each size brake is as follows:

MB-210 and MB-210L.....	1 Qt.
MB-250 & 280.....	2 Qts.
MB-320.....	5 Qts.

## 4-5 TYPE OF OIL

Use only Mobil Automatic Transmission Fluid ATF-210 Type "F" or Mobil Multi-purpose Automatic Transmission Fluid.

Other fluids may be used for special applications.

**Always use the type of fluid specified on the name plate. If the name plate is missing or if there is any doubt about the correct fluid to use contact Force Control Industries, Inc**

(See next page for Vertical Mounted Brakes.)

## 4-6 CHANGING THE OIL (MB-210 and MB-210L Vertical Down Brake)

(See Figure 4.2)

1. Remove the Pipe Plug (#64) and drain the oil out of the Coupler Brake.
2. Replace the Pipe Plug (#64).
3. Remove the Pipe Cap (#67) and fill the brake with fresh oil to the top of the Pipe Nipple (#71).
4. Replace the Pipe Cap (#67).

**NOTE: Consult Force Control Industries, Inc. or a certified Installation Drawing for lubrication information on other size Coupler Brakes and vertical mounting configurations.**

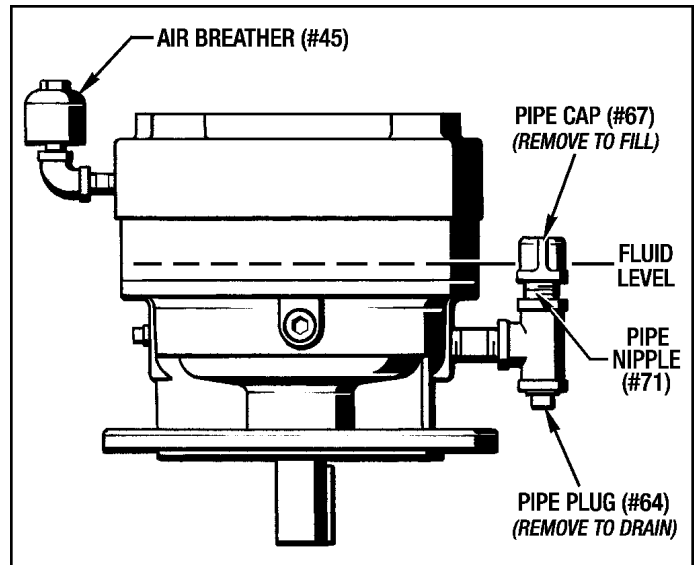

Figure 4.2 - MB-210 & MB-210L Vertical Down Brake Lubrication

## Section 5 OPERATIONAL CHECKS

### WARNING

Make these Operational Checks only when the brake unit is not in operation. Open the motor disconnect and lock it out to avoid any personal injury.

### 5-1 OPERATIONAL CHECKS

Provisions for manual operation is to be made if the brake has been removed for service and repair. Set up a temporary manually controlled air supply with a quick acting shut-off valve and a pressure gauge. (See Figure 5.1)

1. Apply air pressure to the brake and quickly shut the air off. Observe the pressure gauge to see if there is a significant pressure drop.

**If there is a pressure drop of 5 PSI or more within 30 seconds, then the brake is not operating properly.**

This would indicate that the piston seals or gaskets are worn or damaged and would need replaced.

2. Exhaust the air pressure and attempt to manually turn the Hub (#2) extension. The hub should be locked in position. If the hub can be turned then the piston did not return to the normal braked position.

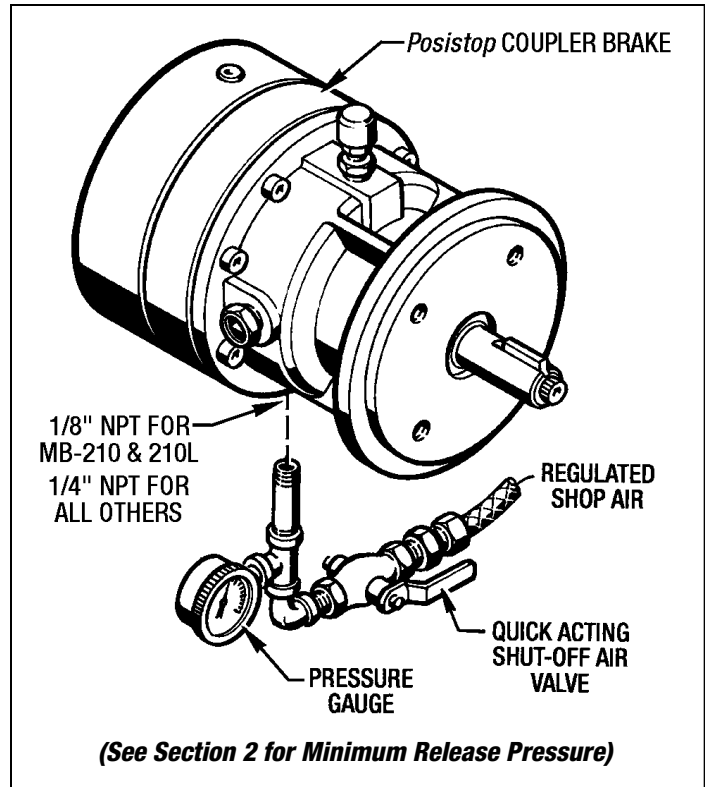

Figure 5.1 - Set-Up for Operational Checks

## Section 6 TROUBLESHOOTING

### 6-1 TROUBLESHOOTING CHART

TROUBLE	POSSIBLE CAUSE	REMEDY
A. Brake fails to engage properly.	Pistons sticking or binding.  Worn Friction Discs.  Weak or broken springs.  Air pressure not exhausting or slow in exhausting.	Disassemble to the extent necessary and inspect for damaged parts.  Replace brake stack.  Replace as needed.  Check control valve or muffler and clean or replace as necessary.
B. Brake engages too quickly.	Low oil level.	Check oil level and correct.
C. Noise and vibration.	Improper or loose mounting on motor and/or gear reducer.	Check mounting bolts and alignment. If partial disassembly is required refer to Section 3 - Installation.
D. Brake fails to disengage properly.	Low air pressure.  Piston sticking or binding  Control valve not functioning properly.	Increase air pressure. (See Section 2)  Disassemble to the extent necessary and inspect for damaged parts.  Check valve operation and replace if necessary.
E. Brake overheats (Over 225° F.)	Brake not engaging or disengaging properly causing excessive slippage.  Improper oil level.	Refer to troubles A and D.  Check oil level and correct.
F. Oil leakage.	Oil seal lip or wear sleeve damaged.  Bad alignment.  External bolts not tight.  Gaskets damaged.	Check for oil leaking around shaft. Replace if necessary.  Check and correct alignment.  Tighten all external bolts.  Check and replace if necessary.
G. Oil leakage at breather.	Oil level too high.	Drain excess oil.
H. Brake does not repeat.	Air pressure changed.  *Oil temperature changed.  Inconsistent stopping signal.	Check and adjust air pressure.  Check temperature.  Check control circuit.

\* - **NOTE:** For installations requiring precise starting and stopping, operating temperatures are very important. Operating temperatures between 116° F. and 165° F. are recommended.

## 6-2 MEASURING BRAKE STACK HEIGHT

To determine whether or not the Brake Stack is worn enough to replace, the Stack has to be measured.

Clamp the Brake Stack in an arbor press and measure the height as shown in *Figure 6.1*.

**NOTE** - On Vertical Units do not include the Separator Springs (#17) when measuring the **Stack Height**.

**The Minimum Stack Height for each Posistop Coupler Brake is as follows:**

**MB-210 & MB-210L** .....(.482")

**MB-250 & MB-280** .....(.980")

**MB-320** .....(.980")

If the **Brake Stack Height** measures the **Minimum Brake Stack Height** or under, replace the Brake Stack.

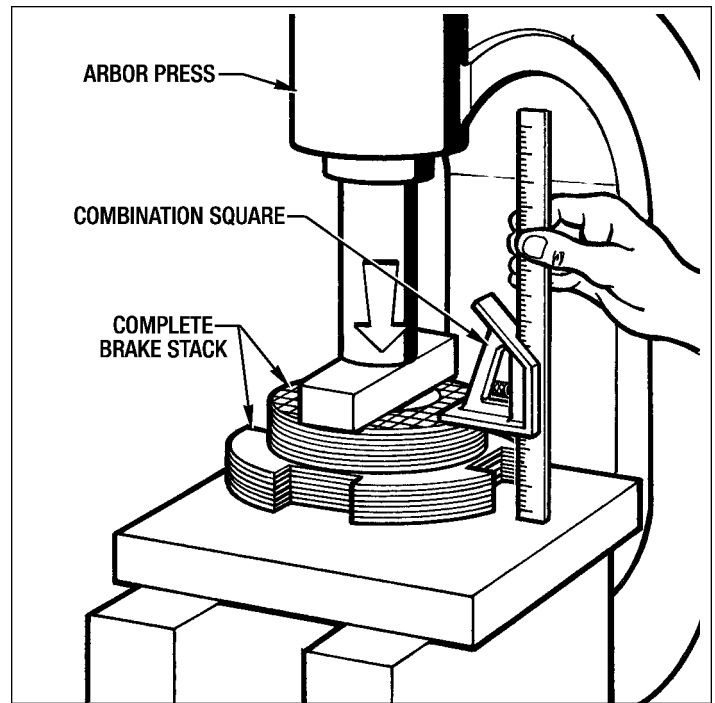

*Figure 6.1 - Measuring Brake Stack Height*

## Section 7 DISASSEMBLY

### 7-1 GENERAL DISASSEMBLY INFORMATION

#### WARNING

Before attempting to disassemble or remove the *Posistop Coupler Brakes*, open the motor disconnect, shut-off the control electrical supply and the air supply. Lock them all out to avoid any personal injury.

Support and block all loads on vertical units before removing or disassembly of the brake.

Unless the Brake is to be completely overhauled, it should only be disassembled to the extent necessary to gain access to the worn or damaged parts.

See the following Figures in **Section 10** for a visual reference to all parts.

*Figure 10.1 - MB-210, 210L Posistop Coupler Brake*

*Figure 10.2 - MB-250, MB-280 & MB-320 Posistop Coupler Brake*

*Figure 10.3 - Pneumatic Control Valve Mounting Kit.*

*Figure 10.4 - Vertical Installation*

It is recommended that all disassembly and repairs be done on a work bench. Also remove the Drive Motor and Coupler Brake together as an assembly from the Gear Reducer.

### 7-2 REMOVING COUPLER BRAKE AND DRIVE MOTOR FROM GEAR REDUCER

(See Figure 7.1)

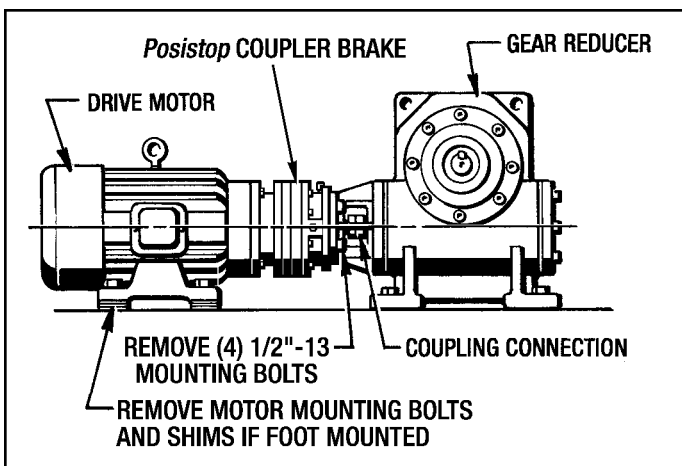

Figure 7.1 - Removing Brake & Motor from Gear Reducer

1. Disconnect any pneumatic lines and electrical connections from the Pneumatic Control Valve.
2. Loosen Coupling Connection as per Manufacturer's Specifications.
3. Remove the (4) 1/2"-13 mounting bolts and lockwashers from the Gear Reducer C-Face Flange.
4. If the Drive Motor is foot mounted, then remove the (4) motor mounting bolts, lockwashers and any shims that might be under the motor feet.
5. With an appropriate sling and overhead hoist pull the Drive Motor and Coupler Brake away from the gear reducer and take it to a work bench for further disassembly.
6. Remove the Key (#180) out of the Hub (#2) keyway for the MB-210 and Key (#113) for all other sizes.
7. Drain all the oil out of the brake as described in **Section 4 - Lubrication**.

### 7-3 REMOVING END HOUSING (#9) FOR ACCESS TO THE BRAKE STACK

(See Figure 7.2 on next page.)

If replacement of the Brake Stack is the only repair to be made, the End Housing (#9) just has to be removed to gain access to the Brake Stack. The remaining brake assembly does not have to be taken off the drive motor.

1. Remove the (8) Screws (#72) and (8) Lockwashers (#127) from the End Housing (#9).

**NOTE** - If you have a brake mounted control valve, there will also be (2) Screws (#273) and (2) Lockwashers (#275). Remove them and disconnect the air hose under the brake. Take the Control Valve (#270) and Mounting Bracket (#271) off the End Housing (#9). (See Figure 7.2 on next page.)

2. Pry the End Housing (#9) loose and pull it straight back off the remaining brake assembly. **Be very careful not to damage the lip of Oil Seal (#35) located in the End Housing (#9).**
3. Remove the O-Ring (#30) from the Piston Housing (#10) and discard it.
4. Remove the **Brake Stack** from the Hub (#2) spline and the (4) lugs on the Piston Housing (#10).
5. Measure the Brake Stack Height as described in **Section 6-2 - Trouble Shooting** to see if the Brake Stack is worn enough to be replaced.

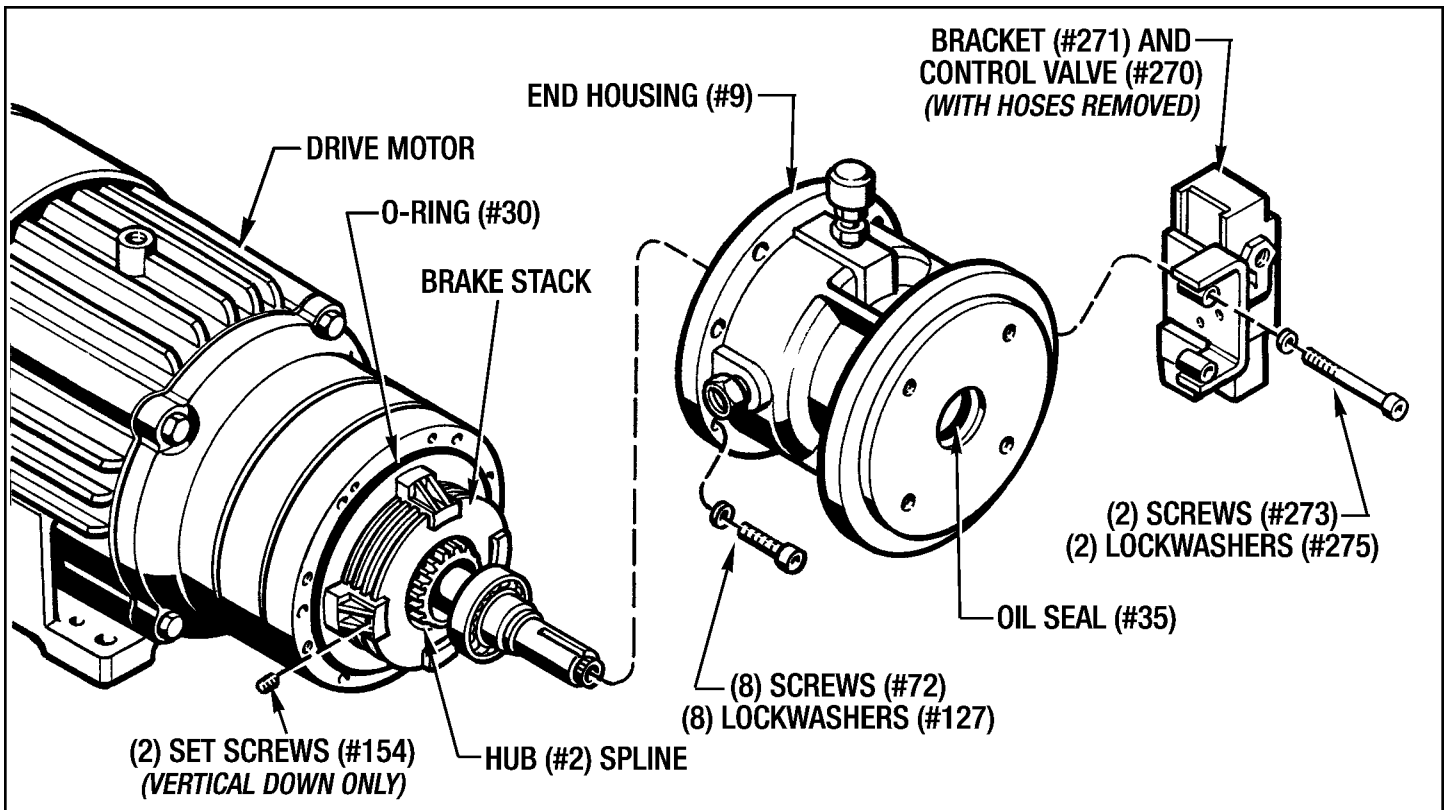

Figure 7.2 - Removing End Housing (#9) For Access to Brake Stack

### 7-4 REMOVING THE HUB (#2)

(See Figures 10.1 and 10.2)

1. Remove the Nut (#136), Lockwasher (#168) and the Collet Locking Stud (#156) from the end of the Hub (#2) with either of the (2) following Methods.

**Method #1** - After the Nut (#136) and Lockwasher (#168) has been removed, use a flat head screw driver to remove the Collet Locking Stud (#156).

If you are unable to loosen the Collet Locking Stud (#156) with a screw driver then use **Method #2**.

**Method #2** - After the Nut (#136) and Lockwasher (#168) has been removed, install a Coupling Nut to the end of the Collet Locking Stud (#156) and then a Hex Hd. Screw to lock the Coupling Nut to the Collet Locking Stud (#156) as shown in Figure 7.3. You

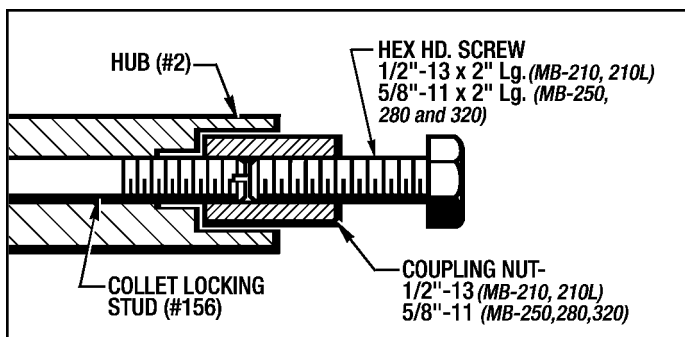

Figure 7.3 - Removing Collet Locking Stud (#156)

should now be able to apply enough torque to remove the Collet Locking Stud (#156) from the Hub (#2) and Collet (#110)..

A special **Threaded Rod "A"** and **Jack Bolt** now has to be used to loosen the Collet (#110) from the bore in the Hub (#2). Dimensions and Specifications are given in Figure 7.4 for each size Coupler Brake and output shaft diameter.

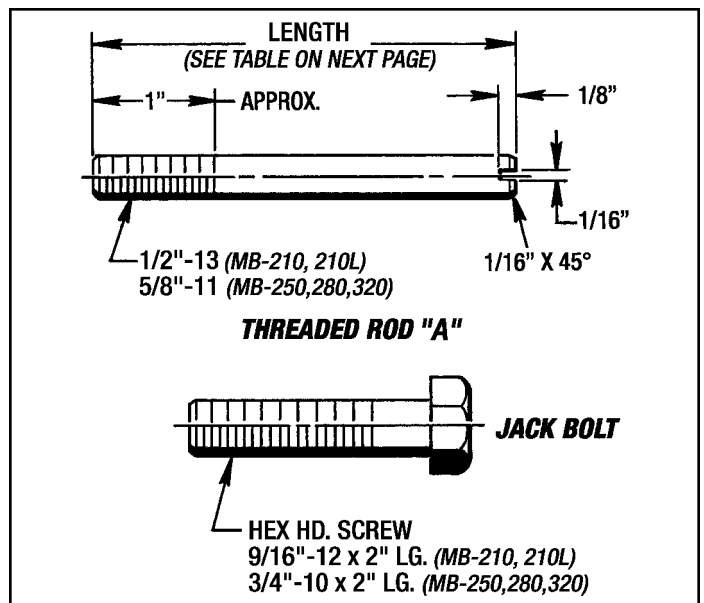

Figure 7.4 - Disassembly Tools

### THREADED ROD "A" LENGTH

BRAKE SIZE	ROD No.	OUTPUT SHAFT DIA.	THREADED ROD "A" LENGTH
MB-210 MB-210L	#A1	1.125"	6.25"
	#A2	1.375"	5.00"
MB-250	#A3	1.125"	9.25"
	#A4	1.375"	
	#A5	1.625"	
MB-280	#A6	1.625"	9.50"
	#A7	1.875"	
MB-320	#A8	1.625"	Contact Factory.
	#A9	1.875"	

2. Insert the **Threaded Rod "A"** into the end of the Hub (#2) and thread it into the Collet (#110) with a flat head screw driver. Leave about 1-1/4" from the end of the Hub (#2) as shown in *Figure 7.5*.
3. Screw the **Jack Bolt** into the Hub (#2) and tighten to release the Collet (#110). Remove the **Jack Bolt** and **Threaded Rod "A"**.

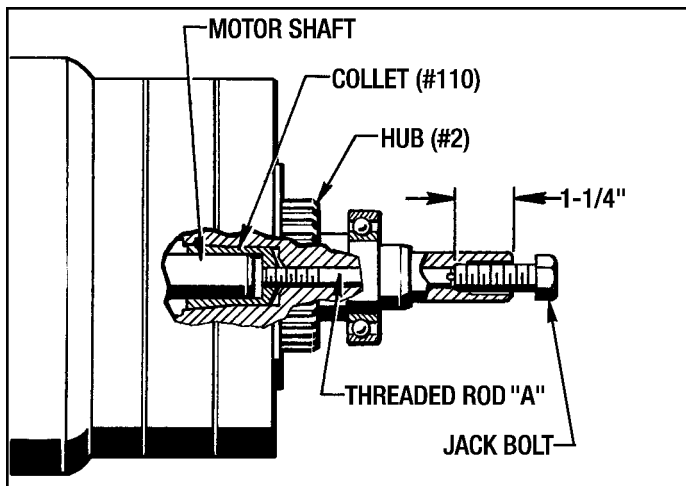

Figure 7.5 - Loosening Collet (#110) from Hub (#2)

4. Grab the Hub (#2) and carefully pull it out of the brake and off the motor shaft and Collet (#110).

**CAUTION - Be very careful not to damage the Oil Seal (#31) lip when removing the Hub (#2).**

### 7-5 HUB (#2) DISASSEMBLY

#### A. Removing Wear Sleeves (#32) and (#86)

1. Set the Hub (#2) into appropriate V-Block Supports as shown in *Figure 7.6*. With a 5/8" wide chisel and a mallet, make 6 to 8 notches in the Wear Sleeve (#32). Pry the Wear Sleeve (#32) off the Hub (#2). Use the same procedure to remove Wear Sleeve (#86).

#### B. Removing Bearing (#20)

1. Use a standard Bearing Puller to remove the Bearing (#20) from the Hub (#2) as shown in *Figure 7.7*.

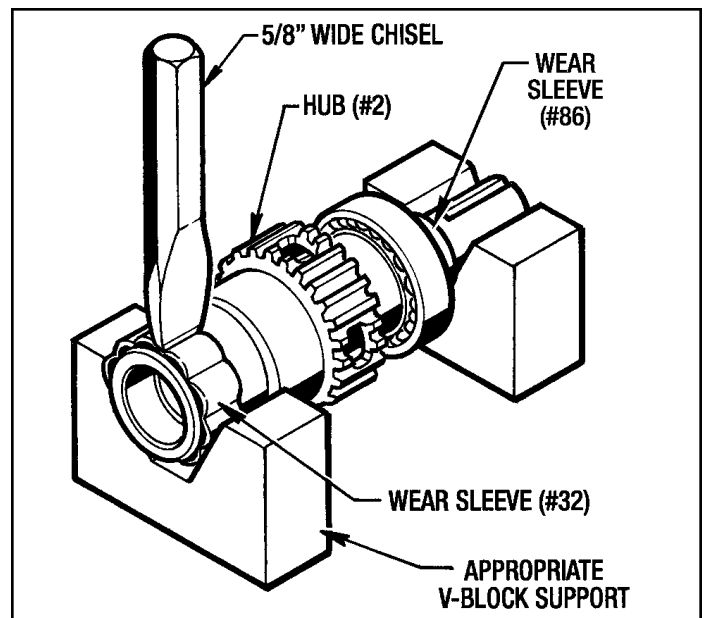

Figure 7.6 - Removing Wear Sleeve (#32)

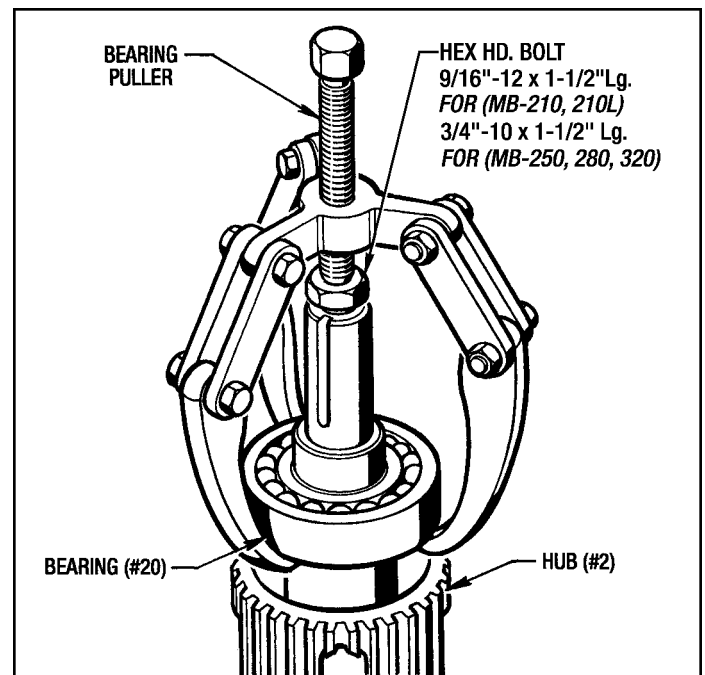

Figure 7.7 - Removing Bearing (#20)

### 7-6 REMOVING PISTON HOUSING (#10) TO REPLACE PISTON SEALS

#### A. Posistop MB-210 & MB-210L Coupler Brake Only (See Figures 7.8 and 10.1)

1. Take out the (6) Screws (#153) and (6) Lockwashers (#128) from the Piston Housing (#10).

**CAUTION - This Piston Housing (#10) is under spring pressure so use caution and carefully, in an even manner, back out these (6) screws to avoid personal injury.**

2. Lift the Piston Housing (#10) and Piston (#3) Sub-Assembly off the Housing (#8).
3. Take the Springs (#36) out of the spring pockets. Make a free hand sketch of the position of these springs. It will help you at reassembly.
4. Remove the (6) small O-Rings (#34) from the Piston Housing (#10) and the large O-Ring (#104) from the lip on the Housing (#8).
5. Push the Piston (#3) out of the Piston Housing (#10).
6. Remove the Liner (#42) and O-Ring (#39) from the groove in the Piston Housing (#10). Next remove the Liner (#43) and both O-Rings (#40) from the groove in the Piston (#3). Discard all Liners and O-Rings.

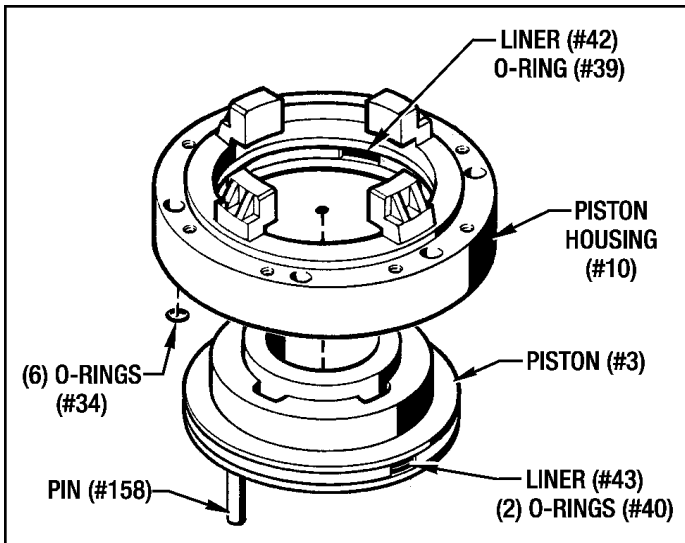

Figure 7.8 - Removing Piston Seals on Size MB-210

### B. Posistop MB-250, 280 & 320 Coupler Brakes

(See Figures 7.9 and 10.2)

1. Remove the (8) Screws (#151) and (8) Lockwashers (#128) from the Housing (#8).
2. Pull the Piston Retainer (#11), Piston Housing (#10) and Piston (#3) Sub-Assembly away from the Housing (#8).

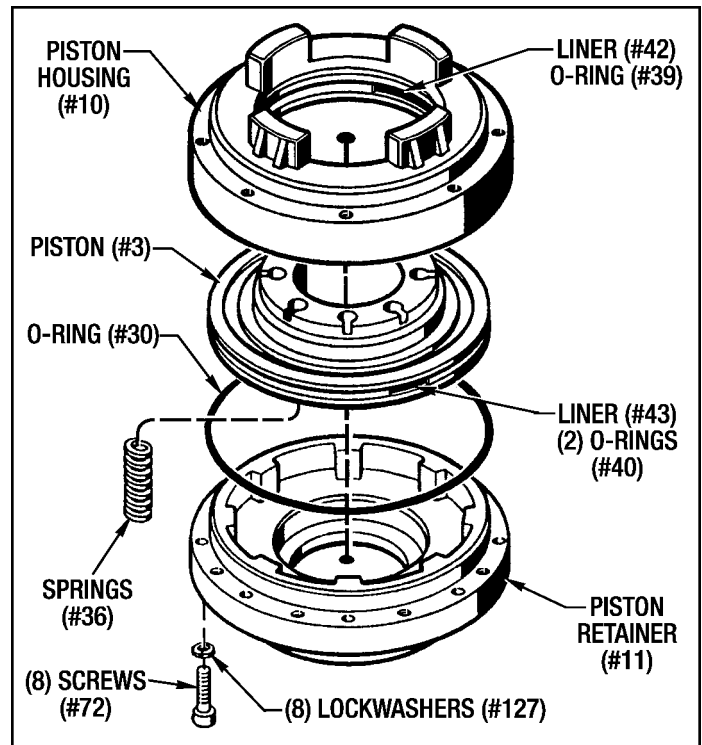

Figure 7.9 - Removing Piston Seals on Sizes MB-250, 280 and 320

3. Take the O-Ring (#33) out of the groove in the face of the Housing (#8).
  4. Remove the (8) Screws (#72) and (8) Lockwashers (#127) that attaches the Piston Retainer (#11) to the Piston Housing (#10)
- CAUTION - This Piston Retainer (#11) is under spring pressure so use caution and carefully, in an even manner, back out these (8) screws to avoid personal injury.**
5. Push the Piston (#3) out of the Piston Housing (#10).
  6. Remove the Liner (#42) and O-Ring (#39) from the groove in the Piston Housing (#10). Next remove the Liner (#43) and both O-Rings (#40) from the groove in the Piston (#3). Discard all Liners and O-Rings.

---

---

## Section 8 CLEANING & INSPECTION

### 8-1 CLEANING AND INSPECTION

Clean metal parts in a suitable solvent and dry in a stream of low pressure compressed air. The Brake Drive Plates (#13), or Drive Plates (#18) can be cleaned in a solvent, but **DO NOT clean the Brake Friction Discs (#12) in solvent.** Use only a clean, dry and lint-free rag to clean these Friction Discs. (Solvent will damage the resilient paper-based friction material used on the Friction Discs. **Keep the Drive Plates and Friction Discs in the same order as they were removed.** After cleaning, inspect parts for cracks, distortion, scoring, nicks, burrs or other damage would affect serviceability. Pay particular attention to the following:

1. Check the Friction Discs wear surfaces for scoring, galling or evidence of uneven wear.
2. Check the brake Drive Plates for scoring or galling. Make sure they are flat. If a perceptible ridge is worn in any of the Drive Plates, replace all of the Drive Plates and Friction Discs as a complete set.
3. Carefully check the piston and bore surfaces for nicks, scratches, scoring or other damage which would affect operation or cause leakage.
4. Carefully check the Piston Liners (#42) and (#43) and the O-Rings (#39) and (#40) for wear or any condition that would cause leakage.

5. Pay particular attention to the Wear Sleeve (#32) and (#86) located on the Hub (#2) and the (2) Oil Seals (#31) and (#35). Check for nicks or scratches which would cause leakage. Replace any damaged parts.
6. It is not necessary to remove the Ball Bearing (#20) to check the operation. Slowly rotate the free race of the bearing by hand checking to see if it turns freely without any rough or flat spots.
7. Periodically remove the Muffler (#282) located in the exhaust port of the Pneumatic Control Valve (#270) and clean it with a suitable solvent.

### 8-2 REPAIR AND REPLACEMENT

A fine stone or crocus cloth may be used to remove minor surface defects from parts so long as the operating or sealing action of the part is not affected. The use of coarser abrasives or other machining methods should not be attempted. Otherwise, damaged parts should be replaced.

***Replacement is recommended also for the following, as applicable:***

1. Replace all O-Rings, Liners and Oil Seals removed during the course of disassembly.
2. Replace all Brake Stack Components - Friction Discs and Drive Plates in complete sets only.

# Section 9 REASSEMBLY

## 9-1 GENERAL REASSEMBLY INSTRUCTIONS

See the following *Figures* in **Section 10** for a visual reference to all parts.

**Figure 10.1 - MB-210 and MB-210L Coupler Brake**

**Figure 10.2 - MB-250, 280 and 320 Coupler Brake.**

**Figure 10.3 - Pneumatic Control Valve Mounting Kit.**

Note the following general reassembly instructions as applicable:

1. Lubricate O-Rings, Liners and Oil Seal lips with **"Mobilith" SHC-PM Synthetic Grease**, or equivalent, immediately before reassembly or the installation of mating parts. This will be referred to as **White Grease** hereafter in the Reassembly Instructions.
2. The Ball Bearing (#20) can be installed on the Hub (#2) either of two ways. It can be heated up to 200° F. and just dropped on the shaft or it can be pressed on with an arbor press.
3. Use **Red Loctite #271** when installing the Wear Sleeves (#32) and (#86) on the Hub (#2).
4. Use Removable **Blue Loctite #272** on the collet end of the Collet Locking Stud (#156).
5. Use **Permatex #30 Sealant** on the O.D. of both Oil Seals (#31) and (#35) when installing them.
6. Any Cap Screws that have Lockwashers do not require any thread adhesive to be applied to the threads.

## 9-2 MOUNTING SCREWS-TORQUE REQUIREMENTS

SCREW SIZE	TORQUE
1/4"-20 .....	7 Lb. Ft.
5/16"-18 .....	14 Lb. Ft.
3/8"-16 .....	25 Lb. Ft.
7/16"-14 .....	40 Lb. Ft.
1/2"-13 .....	60 Lb. Ft.
5/8"-18 .....	120 Lb. Ft.

## 9-3 INSTALLING OIL SEALS

1. First thoroughly clean the bores in both Housings (#8) and (#9) with a suitable solvent. Make sure they are clean and free of any foreign material.
2. Coat the oil seal bores with a thin coat of **Permatex #30 Sealant**.
3. Press the Oil Seal (#31) into the Housing (#8) with an arbor press until it bottoms out on the retaining shoulder.
4. Press the Oil Seal (#35) into the Housing (#9) with an arbor press until it bottoms out on the retaining shoulder.

5. Clean off any excess sealant.

## 9-4 INSTALLING HOUSING (#8) TO DRIVE MOTOR

(See *Figures 10.1 and 10.2*)

1. Make sure that the motor shaft, pilot diameter and mating surfaces of the C-Face Flange is clean and free of any nicks, burrs or anything that would not allow the Housing (#8) to seat properly.

### A. MB-210 and MB-210L Coupler Brake

2. Attach the Housing (#8) to the drive motor face with (4) Dyna-Seals (#126) and (4) Screws (#152). **Use Blue Loctite #242 and Torque to 60 Lb. Ft.**

**NOTE** - If the Hub (#2) has an alignment step on it, then install the Collet (#110) & Hub (#2) on the shaft now. (See **Section 3-1 and Figure 3.2.**)

### B. MB-250, 280 and 320 Coupler Brake

2. Attach the Housing (#8) to the drive motor face with (4) Lockwashers (#128) and (4) Screws (#150). **Torque to the following Specifications:**

**MB-250.....60 Lb. Ft.**  
**MB-280 & 320.....120 Lb. Ft.**

## 9-5 PISTON (#3) AND PISTON HOUSING (#10) REASSEMBLY (See *Figures 10.1 & 10.2*)

### A. MB-210 and MB-210L Coupler Brake

1. Lubricate the (2) O-Rings (#40) and the Teflon Liner (#43) with **White Grease** and install them onto the Piston (#3). (See *Figure 9.1 below.*)

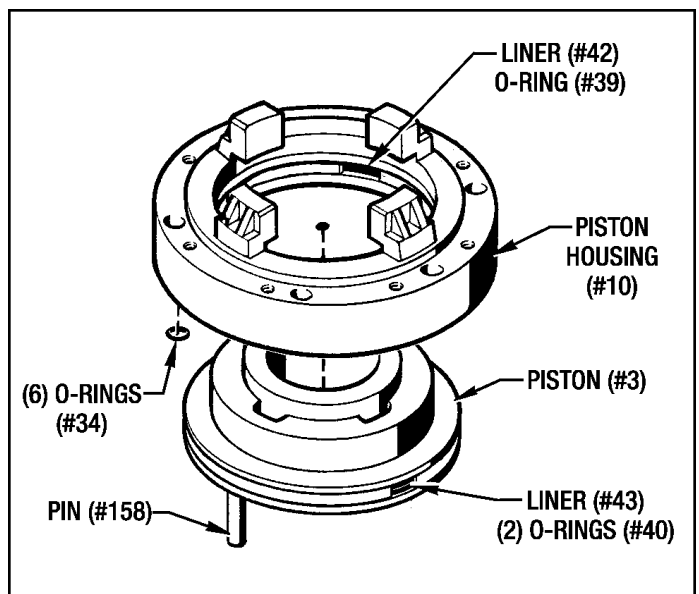

Figure 9.1 - Piston & Piston Housing Reassembly (MB-210, 210L)

- Lubricate the (2) O-Rings (#39) and the Teflon Liner (#42) with **White Grease** and install them into the Piston Housing (#10).
- Insert the Piston (#3) into the Piston Housing (#10).  
Coat all mating surfaces and liners with a thin coat of **White Grease** before installing the Piston (#3). **Also be very careful not to damage the Liners when installing this Piston (#3) into the Piston Housing (#10).**
- Place the correct number of Springs into the spring pockets in the Housing (#8) for your required torque. See Figure 9.2 for Correct Spring Placement.

**White Grease** can be used to hold them in place.

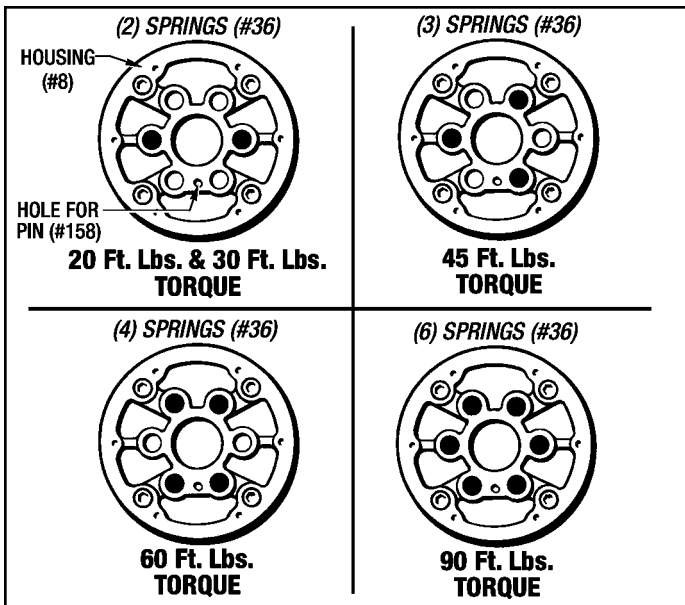

Figure 9.2 - Correct Spring (#36) Placement (MB-210, 210L)

- Place the large O-Ring (#104) on the Housing (#8) and the (6) small O-Rings (#34) into the (6) recesses in the back face of the Piston Housing (#10).
- Attach the Piston Housing (#10) to the Housing (#8) with (6) Screws (#153) and (6) Lockwashers (#128). Tighten these screws down in an even manner to correctly compress the Springs (#36). **Torque to 14 Lb. Ft.** Make sure that the Anti-Rotational Dowel Pin (#158) in the Piston (#3) is aligned with the hole in the Housing (#8) shown in Figure 9.2.

### B. MB-250, 280 and 320 Coupler Brake

- Lubricate the (2) O-Rings (#40) and the Teflon Liner (#43) with **White Grease** and install them onto the Piston (#3). (See Figure 9.3 below.)
- Lubricate the (2) O-Rings (#39) and the Teflon Liner (#42) with **White Grease** and install them into the Piston Housing (#10).

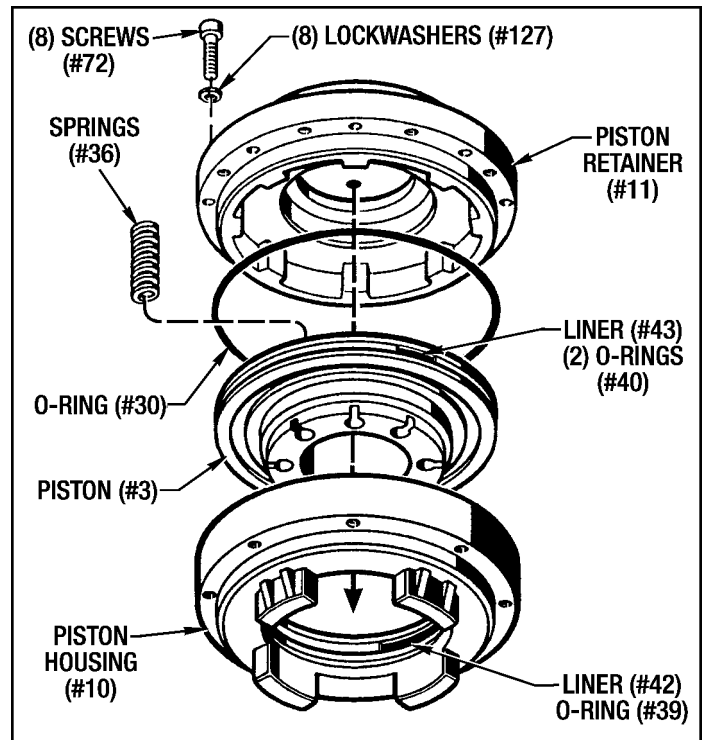

Figure 9.3 - Piston, Retainer and Housing Reassembly MB-250, 280 and 320

- Insert the Piston (#3) into the Piston Housing (#10).  
Coat all mating surfaces and liners with a thin coat of **White Grease** before installing the Piston (#3). **Also be very careful not to damage the Liners when installing this Piston (#3) into the Piston Housing (#10).**
- Place the correct number of Springs into the spring pockets in the Housing (#8) for your required torque. See Figure 9.4 for Sizes MB-250 and MB-280 correct spring placement. See Figure 9.5 for Size MB-320.

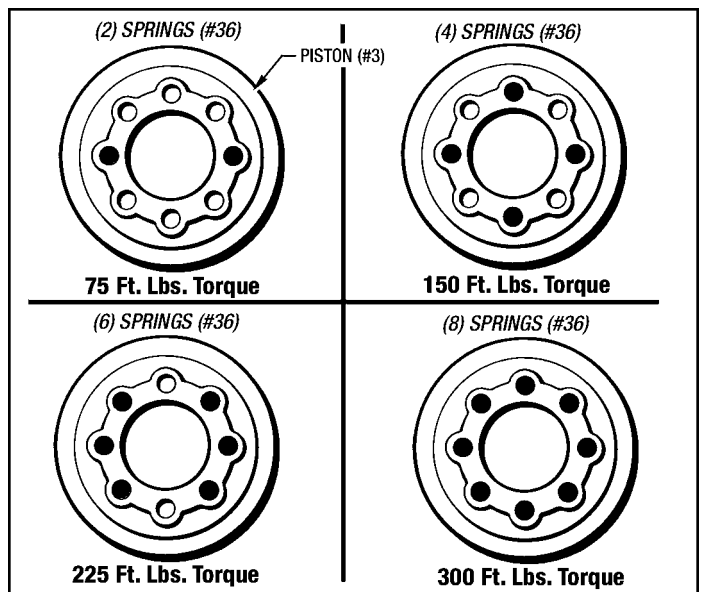

Figure 9.4 - Correct Spring Placement (MB-250 & 280)

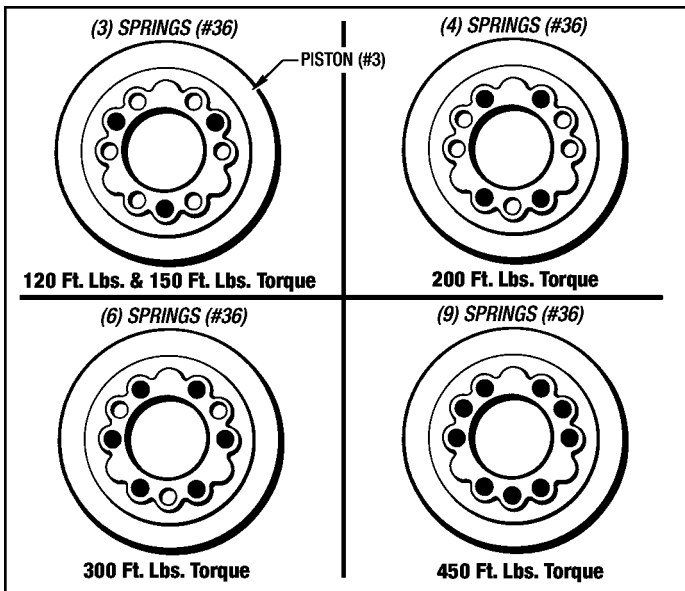

Figure 9.5 - Correct Spring Placement (MB-320)

- Lubricate the O-Ring (#30) with a little **White Grease** and place it on the Piston Retainer (#11). (See Figure 9.4)
- Attach the Piston Retainer (#11) to the Piston Housing (#10) with (8) Screws (#72) and (8) Lockwashers (#127). Tighten these (8) Screws (#72) down in an even manner to compress the Springs (#36) correctly. **Torque to 25 Lb. Ft.**

## 9-6 HUB (#2) REASSEMBLY

### A. Installing Wear Sleeve (#32)

- First make sure the mating surface of the Hub (#2) is thoroughly cleaned. Apply **Red Loctite #271** to the surface.
- With an arbor press and flat plate, install this Wear Sleeve (#32) on to the Hub (#2) as shown in Figure 9.6. Press until the Wear Sleeve bottoms out on the shoulder. Clean off any excess Loctite.

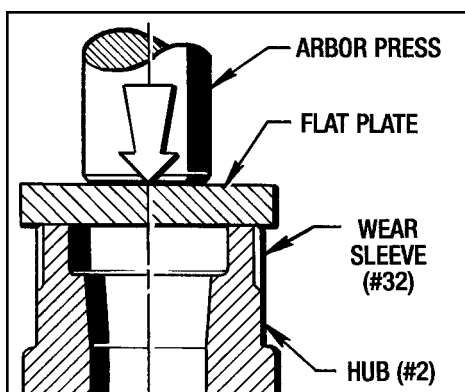

Figure 9.6 - Installing Wear Sleeve (#32)

### B. Installing Bearing (#20)

**Method #1** - Heat up the Bearing (#20) to 200° F. and drop it on to the Hub (#2).

Make sure the Bearing (#20) is completely seated on the shoulder.

**CAUTION - Be sure to wear suitable work gloves when handling heated parts.**

**Method #2** - Press the Bearing (#20) on to the Hub (#2) with an arbor press and appropriate sleeve as shown in Figure 9.7. Dimensions are given for this Bearing Installation Sleeve in the back of this manual.

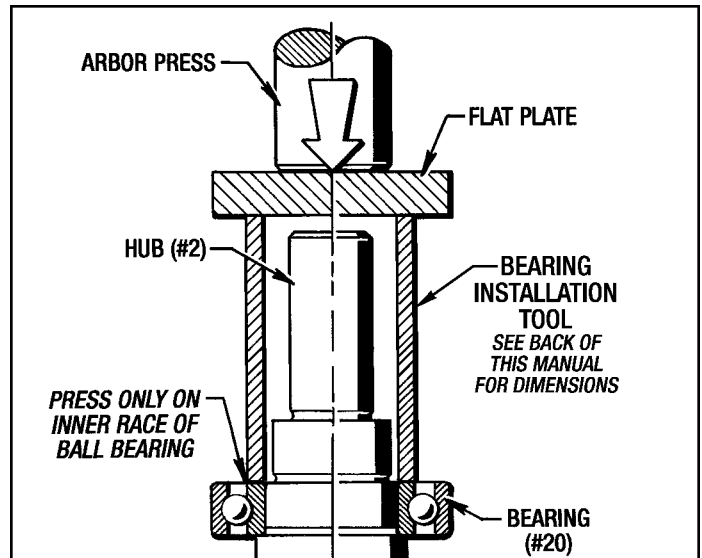

Figure 9.7 - Installing Bearing (#20)

### C. Installing Wear Sleeve (#86)

- First make sure the mating surface of the Hub (#2) is thoroughly cleaned. Apply **Red Loctite #271** to the mating surface of the Hub.
- Install the Wear Sleeve (#86) on to the Hub (#2) with an arbor press and the appropriate Wear Sleeve Assembly Tool as shown in Figure 9.8.

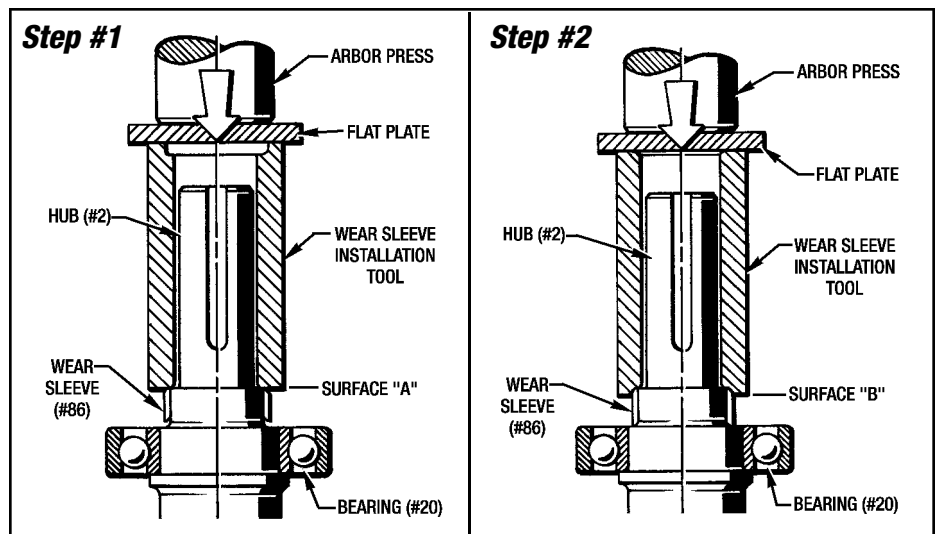

Figure 9.8 - Installing Wear Sleeve (#86)

**FORCE CONTROL INDUSTRIES, INC.**



MEX (55) 53 63 23 31  
QRO (442) 1 95 72 60

MTY (81) 83 54 10 18  
ventas@industrialmagza.com

**Step #1** - Use the flat **Surface "A"** to press the Wear Sleeve (#86) on as far as it will go.

**Step #2** - Turn the tool over and use **Surface "B"** to finish seating the Wear Sleeve (#86) on the Hub (#2). Clean off any excess Loctite.

**NOTE** - Dimensions and Part Numbers are given for this Wear Sleeve Assembly Tool in the back of this manual. You have the option to order them from Force Control or to make them yourself.

## 9-7 INSTALLING HUB (#2) INTO BRAKE

### A. MB-210 and MB-210L Coupler Brake

1. Lubricate the lip of the Oil Seal (#31), installed in Housing (#8), and the Wear Sleeve (#32), on the back end of the Hub (#2), with a little **White Grease**.
2. Slide the Collet (#110) on to the motor shaft as far as it will go.

**IMPORTANT** - Do not use any Molybdenum Disulfide "MOLYKOTE" or any other similar lubricant on the motor shaft. The collet locking element is keyless and depends on friction to transmit torque from the brake to the motor shaft.

3. Slide the Hub (#2) over Collet (#110) and into the Oil Seal (#31). **Be careful not to damage the lip on the Oil Seal (#31).**

**NOTE**- If the Hub has an **Alignment Step** in it the Hub could have been installed on the Collet before the Piston Housing was attached aligning the **Step** with the outer face of Housing (#8) as shown in **Section 3-1**.

4. Position the Hub (#2) so the end of the spline is **.563" (9/16")** from the face of the Piston (#3) as shown in **Figure 9.9**.

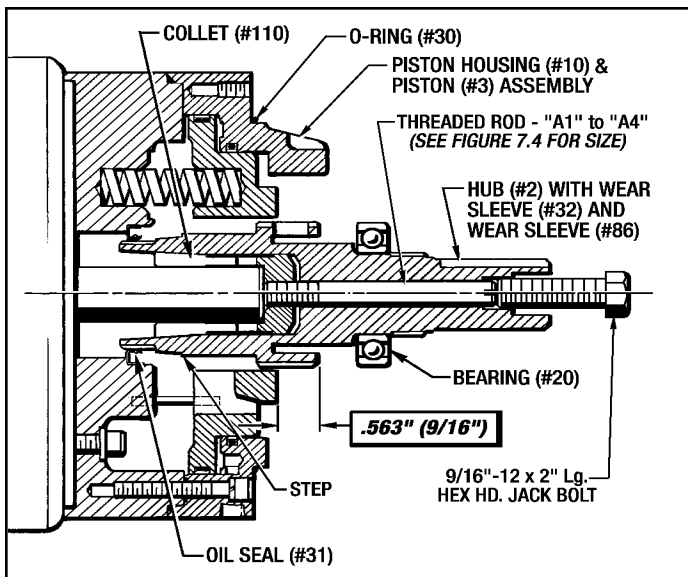

Figure 9.9 - Installing MB-210 & MB-210L Hub (#2)

5. Install the correct Threaded Rod "A" into the Collet (#110) approx. 4 or 5 turns. **Hand tighten** the Jack Bolt into the end of the Hub (#2) just until it makes contact with the Threaded Rod "A". **Do not tighten any further.** (See **Figure 9.9** below.)

### B. MB-250 and MB-280 Coupler Brake

1. Place the Collet (#110) on the motor shaft as far as it will go. (See **Figure 9.10**)
2. Lubricate the lip of the Oil Seal (#31) located in the Housing (#8) with a little **White Grease** or equivalent. Also lubricate the Wear Sleeve (#32) located on the back end of the Hub (#2).
3. Slide the Hub (#2) over the Collet (#110) and into the lip of the Oil Seal (#31).

**CAUTION** - Be careful not to damage the lip of the Oil Seal (#31).

4. Using a steel straight edge, align the **2nd. Shoulder** of the Hub (#2) with the **Outer Face** of Housing (#8) within  $\pm 1/64"$  as shown in **Figure 9.10**.

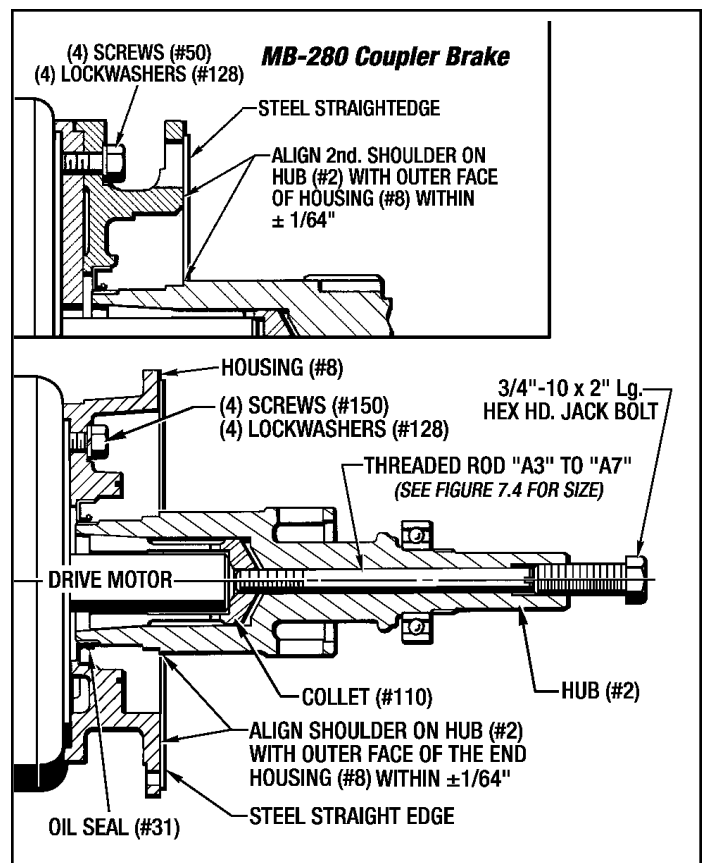

Figure 9.10 - Installing Hub (#2) on MB-250 & 280 Coupler Brake

5. Install the correct Threaded Rod "A" into the Collet (#110) approx. 4 or 5 turns. **Hand tighten** the Jack Bolt into the end of the Hub (#2) just until it makes contact with the Threaded Rod "A". **Do not tighten any further.** (See **Figure 9.10** above.)

### C. MB-320 Coupler Brake

1. Place the Collet (#110) on the motor shaft as far as it will go. (See Figure 9.11)
2. Lubricate the lip of the Oil Seal (#31) located in the Housing (#8) with a little **White Grease** or equivalent. Also lubricate the Wear Sleeve (#32) located on the back end of the Hub (#2).
3. Slide the Hub (#2) over the Collet (#110) and into the lip of the Oil Seal (#31).

**CAUTION - Be careful not to damage the lip of the Oil Seal (#31).**

4. Using a steel straight edge, align the **1st. Shoulder** of the Hub (#2) with the **Outer Face** of Housing (#8) within  $\pm 1/64"$  as shown in Figure 9.11.
5. Install the correct Threaded Rod into the Collet (#110) approx. 4 or 5 turns. **Hand tighten** the Jack Bolt into the end of the Hub (#2) just until it makes contact with the Threaded Rod. **Do not tighten any further.** (See Figure 9.11 below.)

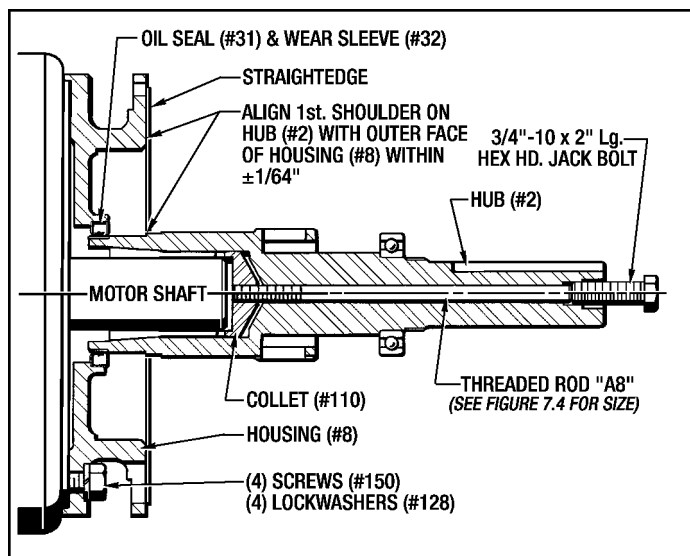

Figure 9.11 - Installing Hub (#2) on MB-320 Coupler Brake

### 9-8 INSTALLING PISTON HOUSING ASSEMBLY

(See Figure 10.2)

#### Sizes MB-250, MB-280 AND MB-320 Only

1. Lubricate the O-Ring (#33) with a little white grease and install it in the inner groove in Housing (#8) for the MB-250. **NOTE** - It is installed on the register of the Piston Retainer (#11) for the MB-280 and MB-320.
2. Attach the Piston Housing Assembly to the Housing (#8) with (8) Screws (#151) and (8) Lockwashers (#129). **Torque to 25 Lb. Ft.**

**CAUTION - Be very careful not to rest the Piston Housing Assembly on the Hub (#2) or even bump the Hub with the Piston Housing Assembly. Doing so could damage the lip of the Oil Seal (#31) installed in Housing (#8).**

### 9-9 INSTALLING THE BRAKE STACK

#### A. Assembly Tips

One side of the steel Drive Plates (#12) and (#18) has a slight radius on all edges due to the manufacturing process.

Install this radius side first, tilting the drive plates slightly to get them started and positioned within the (4) brake lugs.

The Friction Discs (#13) will also go on the Hub (#2) spline easier if also slightly tilted.

#### B. Horizontal Mounted Coupler Brakes

See Section 2-2 Brake Stack Assembly Configurations on Page 4 for the exact quantity of Drive Plates (#12) and Friction Discs (#13) for your Specific Torque Requirements.

1. Apply 60 PSI air pressure to the brake port located on the Piston Housing (#10) to fully retract the Piston (#3).
2. While air pressure is being applied, install the Brake Stack on the Hub (#2) spline and the (4) brake lugs on the Piston Housing (#10).

Always start with a Drive Plate (#12), then a Friction Disc (#13), then another Drive Plate (#12), etc.

**NOTE** - The extra spacer Drive Plates (#12) on Assembly Configurations "A" and "K" should always be installed last, as shown, away from the piston side.

#### C. Vertical Mounted Coupler Brakes

See Section 2-3 Brake Stack Assembly Configurations on Pages 4 and 5 for the exact quantity of Drive Plates (#18) with (4) Separator Springs (#17) each, Friction Discs (#13) and Drive Plates (#12) without Separator Springs (#17).

1. Apply 60 PSI air pressure to the brake port located on the Piston Housing (#10) to fully retract the Piston (#3).
2. While air pressure is being applied, install the Brake Stack on the Hub (#2) spline and the (4) brake lugs on the Piston Housing (#10).

Always start with a Drive Plate (#18) with the (4) Separator Springs (#17) pointed away from the Piston (#3), then a Friction Disc (#13), then another Drive Plate (#18), etc. Ending the stack with the correct quantity of Drive Plates (#12) **except where noted on next page.**

**NOTES:**

1. On Brake Stack Assembly Configurations “AVU” and “KVU” (*Vertical Up Mounted Brakes*) the Drive Plates (#12) are installed first, next to the Piston (#3), then the Friction Discs (#13) and the Drive Plates (#18) with the (4) Separator Springs (#17) pointed toward the piston side.

2. On Brake Stack Assembly Configurations “AVD” and “KVD” (*Vertical Down Mounted Brakes*) the Drive Plates (#12) are installed last, away from the piston side. **Also install the (2) Set Screws (#154) into the two opposite lugs.**

**This is done to reduce residual drag or friction on the brake stack in the unclamped position (Running) Mode.**

**9-10 INSTALLING END HOUSING (#9) TO THE BRAKE ASSEMBLY**

(See Figures 10.1 and 10.2)

1. Lubricate the O-ring (#30) and install it on the Piston Housing (#10). Also lubricate the Wear Sleeve (#86) on the Hub (#2) and the lip of the Oil Seal (#35) installed in the End Housing (#9) with a little **White Grease**.
2. Slide the End Housing (#9) over the extended shaft of the Hub (#2) and attach it to the Piston Housing (#10) with (8) Screws (#72) and (8) Lockwashers (#127).

See Figure 10.3 to install the brake mounted Pneumatic Control Valve.

**Torque the screws to the following specifications:**

MB-210, 210L.....14 Lb. Ft.  
 MB-250, 280 & 320.....25 Lb. Ft.

**CAUTION - Be very careful not to damage the lip of the Oil Seal (#35) when installing this End Housing (#9).**

3. Release the air pressure from the brake port.
4. Measure the end of the extended shaft of the Hub (#2) to the C-Face Flange Face of the End Housing (#9) as shown in Figure 9.12.

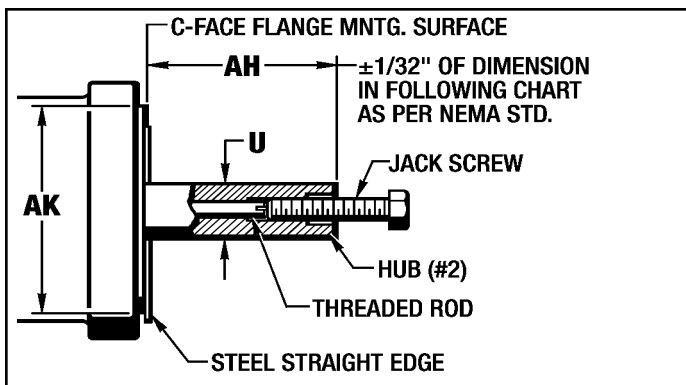

Figure 9.12 - Final Positioning of the Hub (#2)

**NOTE -** Tape a steel straight edge to the C-Face Flange to get an accurate measurement.

**FINAL HUB (#2) ALIGNMENT DIMENSIONS**

BRAKE SIZE	NEMA MOUNTING (Frame Size)	AK (Inches)	U (Inches)	AH (Inches)
MB-210	182T	8.50	1.125	2.63
	184T			2.75
	213U			
	215U			
MB-210L and MB-250	213T	8.50	1.375	3.13
	215T			3.50
	254U			
	256U			
MB-250	254T	8.50	1.625	3.75
	256T			
MB-280	284U	10.50	1.875	4.63
	286U			4.38
	284T			
	286T			
MB-320	324U	12.50	1.875	5.38
	326U			

5. If it measures under the Required Dimension “AH”, then tighten down the Jack Bolt (*Clockwise*) to bring the Hub (#2) out to the Required Dimension. Position tolerance is  $\pm 1/32$ ”.
6. Remove the Threaded Rod and Jack Bolt.
7. Install the **Special Assembly Tool** into the end of the Hub (#2) and into the Collet (#110). Screw the rod about 4 or 5 turns into the Collet (#110). The Tool Number is **601-13-047** for the MB-210, 210L brake and **601-18-002** for the MB-250, 280 and 320.
8. Grab a hold of the handle and yank hard to seat the Collet (#110) completely into the Hub (#2) bore as shown in Figure 9.13.

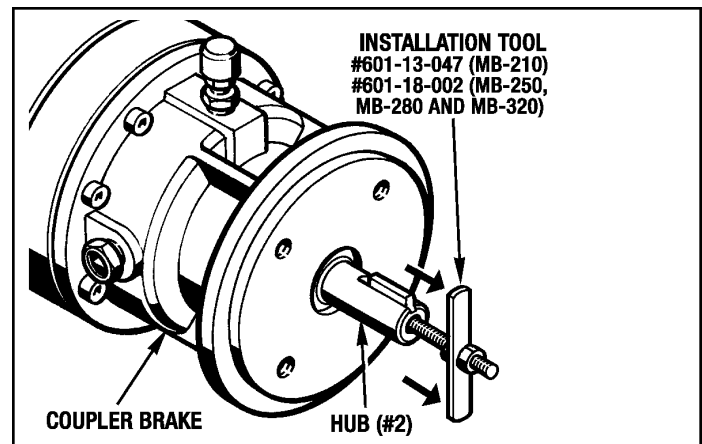

Figure 9.13 - Seating Collet (#110) Completely Into Hub (#2)

9. Install the Key (#180) into the Hub (#2) if required.
10. Remove the Special Assembly Tool and install the Collet Locking Stud (#156), Lockwasher (#168) and Locking Nut (#136). Apply Blue Loctite #242 to the collet end of the Stud (#156).

**Torque the Locking Nut (#136) to the following specifications:**

**A. MB-210 and MB-210L Coupler Brake**

7/8" Dia. Motor Shaft . . . . .	<b>60 Lb. Ft.</b>
1-1/8" Dia. Motor Shaft . . . . .	<b>75 Lb. Ft.</b>
1-3/8" Dia. Motor Shaft . . . . .	<b>60 Lb. Ft.</b>

**B. MB-250, 280 & 320 Coupler Brakes**

1-1/8" Dia. Motor Shaft . . . . .	<b>160 Lb. Ft.</b>
1-3/8" Dia. Motor Shaft . . . . .	<b>180 Lb. Ft..</b>
1-5/8" Dia. Motor Shaft . . . . .	<b>180 Lb. Ft.</b>
1-7/8" Dia. Motor Shaft . . . . .	<b>180 Lb. Ft..</b>

It may be necessary to hold the Hub (#2) while you torque this Collet Locking Nut (#136) down so it does not turn. Use an open end adjustable wrench, or spanner wrench, to hold the hub as shown in *Figure 9.14*.

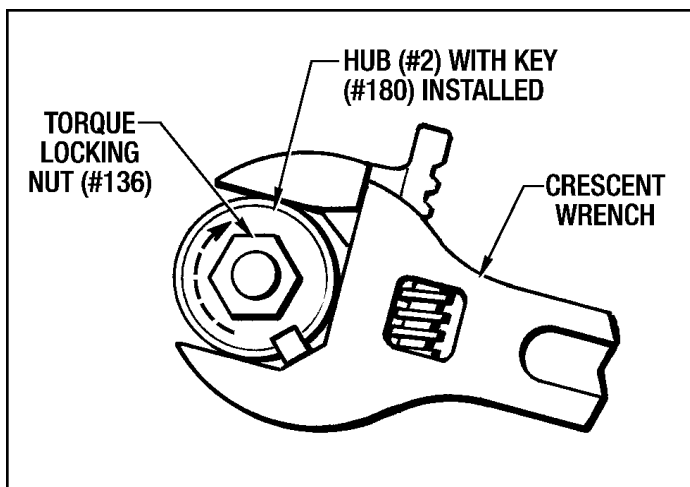

*Figure 9.14 - Holding Hub (#2)*

**9-11 FINAL REASSEMBLY**

1. Install the Air Breather (#44), Sight Gauge (#46) and any other Pipe Plugs and Fittings removed for Disassembly.
2. Check the Operation of the Brake as described in **Section 5 - Operational Checks**.
3. Fill the brake with fresh oil as described in **Section 4 - Lubrication**.
4. Return the brake to the service location.

**9-12 MOUNTING MOTOR & BRAKE TO GEAR REDUCER**

(See *Figure 9.15*)

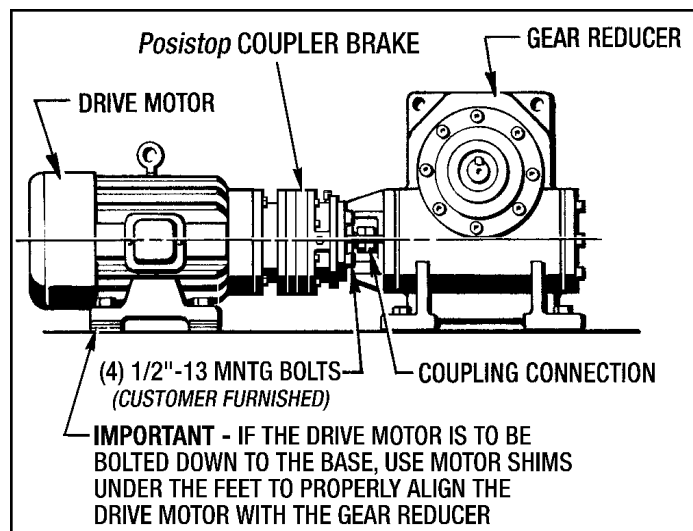

*Figure 9.15 - Motor and Gear Reducer Alignment*

It is recommended that you use a Coupling, rather than a hollow shaft to connect the Hub (#2) to the Gear Reducer.

1. Attach the Drive Motor and Brake Assembly to the Gear Box or Driven Machinery with the (4) 1/2"-13 Mounting Bolts (*Customer Furnished*). **Torque to 60 Lb. Ft.** Connect the coupling as per manufacturer's specifications.
2. If the Drive Motor is to be bolted down to the base, use motor shims under the feet to properly align the drive motor with the gear reducer as shown in *Figure 9.15*. **This is very important so the Coupler Brake will not be pulled down or pushed up.**
3. Connect shop air and electrical service to the Control Valve.

**Your Posistop Coupler Brake is now ready for service.**

# Section 10

## ORDERING REPLACEMENT PARTS

### 10-1 GENERAL INFORMATION

This section illustrates, lists and describes all parts for the **Posistop MB-210, MB-250, MB-280 and MB-320 Coupler Brake.**

Parts are identified on the exploded views with Part Reference Numbers. These Numbers correspond to the Part Reference Number given in the Parts Lists. The Part Name and Quantity Used is also given in the Parts List. This Part Reference Number, Part Name and Quantity should be used when ordering Replacement Parts.

### 10-2 FACTORY REBUILD SERVICE

Reconditioning Service is offered by **Force Control Industries, Inc.** at the factory. A complete factory rebuild will be 50% the cost of a new unit if the housings are reusable. If Housings need to be replaced, there will be an additional cost.

Contact **Force Control Industries, Inc.** for authorization and shipping instruction before returning a drive unit for this service. **Force Control** cannot be responsible for units returned to the factory without prior notice and authorization.

Care must be given to the packing of returned brakes. Always protect mounting surfaces by attaching to a skid. Shipment-damaged brakes always delays repairs. It is usually impossible to recover damage costs from the carrier. When possible, describe the problem experienced on your shipping papers.

Return to: **Force Control Industries, Inc.**  
3660 Dixie Highway  
Fairfield, Ohio 45014  
Phone: (513) 868-0900  
Fax: (513) 868-2105  
E-Mail: [info@forcecontrol.com](mailto:info@forcecontrol.com)

### 10-3 ORDERING REPLACEMENT PARTS

When ordering replacement parts, please specify all of the following information:

1. **Brake Model Number.** (On the Name Plate.)  
(See below.)
2. **Brake Serial Number.** (On the Name Plate.)
3. **Part Reference Number.** (From the parts list or exploded view drawing.)
4. **Part Name.** (From the parts list.)
5. **Quantity.** (From the parts list.)
6. **Complete Shipping Information.**

Failure to include information for items 1 through 6 will only delay your parts order. Unless another method is specified for item 6, parts weighing less than 150 Lbs. will be shipped United Parcel Service. Parts weighing more than 150 Lbs. will be shipped Motor Freight. Air freight and other transportation services are available but only if specified on your order.

### 10-4 NAME PLATE INFORMATION

The Name Plate will be located on the Piston Housing (#10). (See below.)

The name plate is a rectangular label with a double-line border. On the left is the Force Control Industries logo. To the right of the logo, the text reads: "Force Control Industries, Inc. Fairfield, Ohio" and "For Service / Parts Call: 513-868-0900". Below this, it says "Posistop® Brake" followed by a box for "Model No." and another box for "Serial No.". At the bottom left, it says "Use Mobil ATF-210". An arrow points from the "Model Number" text below to the "Model No." box.

Model Number (See next page.)

# Posistop Coupler Brake Model Number Information

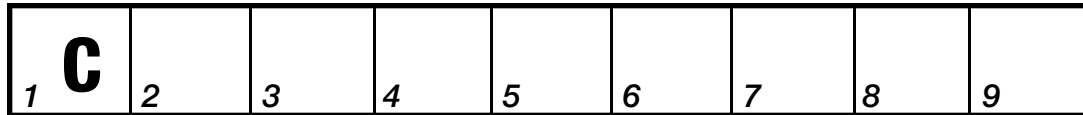

**COUPLER  
BRAKE (1)**

**BRAKE SIZE (2)**

Std.	Euro	
<b>C</b>	<b>K</b>	= 210
<b>Q</b>	<b>T</b>	= 210L
<b>D</b>	<b>L</b>	= 250
<b>E</b>	<b>M</b>	= 280
<b>F</b>	<b>N</b>	= 320

**INPUT SHAFT (3)**

<b>B</b>	= 7/8" Dia. Collet Bore
<b>C</b>	= 1-1/8" Dia. Collet Bore
<b>D</b>	= 1-1/4" Dia. Collet Bore
<b>E</b>	= 1-3/8" Dia. Collet Bore
<b>F</b>	= 1-5/8" Dia. Collet Bore
<b>G</b>	= 1-7/8" Dia. Collet Bore

**STATIC TORQUE (4)**

<b>E</b>	= 20 Ft. Lbs.	<b>L</b>	= 120 Ft. Lbs.
<b>F</b>	= 30 Ft. Lbs.	<b>M</b>	= 150 Ft. Lbs.
<b>G</b>	= 45 Ft. Lbs.	<b>N</b>	= 200 Ft. Lbs.
<b>H</b>	= 60 Ft. Lbs.	<b>P</b>	= 225 Ft. Lbs.
<b>J</b>	= 75 Ft. Lbs.	<b>Q</b>	= 300 Ft. Lbs.
<b>K</b>	= 90 Ft. Lbs.	<b>R</b>	= 450 Ft. Lbs.

**REVISION (9)**  
(By Force Control)

**REDUCER RATIO (7, 8)**

**0 0** = Std. Coupler

Round off to two places. Anything over 99:1 will be a special model number. Use "00" for Standard Coupler

**MOUNTING CONFIGURATION (6)**

<b>H</b>	= Horizontal
<b>V</b>	= Vertical-Output Up
<b>R</b>	= Vertical-Output Down

**OUTPUT SHAFT (5)**  
Standard Only

<b>C</b>	= 1-1/8" Dia.
<b>D</b>	= 1-1/4" Dia.
<b>E</b>	= 1-3/8" Dia.
<b>F</b>	= 1-5/8" Dia.
<b>G</b>	= 1-7/8" Dia.

**REDUCER SIZE (5)**  
Eurodrive Only

With Feet	Without Feet	
<b>A</b>	<b>J</b>	= 42
<b>B</b>	<b>K</b>	= 62
<b>C</b>	<b>L</b>	= 70.
<b>D</b>	<b>M</b>	= 72
<b>E</b>	<b>N</b>	= 80
<b>F</b>	<b>P</b>	= 82
<b>G</b>	<b>Q</b>	= 90
<b>H</b>	<b>R</b>	= 92

**Repair Parts List (Figure 10.1)**  
**Posistop MB-210 and MB-210L COUPLER BRAKE**

REF No.	PART NAME	QTY.	REF No.	PART NAME	QTY.
2	Hub .....	1	*39	O-Ring .....	2
3	Piston .....	1	*40	O-Ring .....	2
8	Housing .....	1	*42	Liner, I.D. Sealing .....	1
9	End Housing .....	1	*43	Liner, O.D. Sealing .....	1
10	Piston Housing .....	1	**45	Air Breather .....	1
*12	Drive Plate		**46	Sight Gauge .....	1
	(Horizontal Brakes)		49	Pipe Plug, 1/4" NPT .....	1
	20 Ft. Lbs. Torque .....	6	52	Threaded Insert .....	4
	30, 45, 60 and 90 Ft. Lbs. Torque .....	4	72	Soc. Hd. Cap Screw, 5/16"-18 x 7/8" Lg. . .	8
	(Vertical Brakes)		74	Pipe Plug, Mag. 1/4" NPT, Sq. Hd. ....	2
	20 Ft. Lbs. Torque .....	4	75	Pipe Plug, 1/2" NPT .....	1
	30, 45, 60 and 90 Ft. Lbs. Torque .....	1	76	Reducer Bushing, 1/2" x 1/4" .....	1
*13	Friction Disc		86	Wear Sleeve .....	1
	20 Ft. Lbs. Torque .....	2	*104	O-Ring .....	1
	30, 45, 60 and 90 Ft. Lbs. Torque .....	3	110	Collet, Taper .....	1
*17	Separator Springs (Vertical Brakes Only)		*126	Dyna-Seal .....	4
	20 Ft. Lbs. Torque .....	8	127	Lockwasher, 5/16" .....	8
	30, 45, 60 and 90 Ft. Lbs. Torque .....	12	128	Lockwasher, 5/16" .....	6
*18	Drive Plate, w/ Rivet (Vertical Brakes Only)		136	Allen Nut. 1/2"-13 .....	1
	20 Ft. Lbs. Torque .....	2	150	Screw. 1/2"-13 x 2-3/4" Lg. (210L Only) . .	4
	30, 45, 60 and 90 Ft. Lbs. Torque .....	3	152	Screw, 1/2"-13 x 1-3/4" Lg. (210 Only) . . .	4
*20	Ball Bearing .....	1	153	Soc. Hd. Cap Screw, 5/16"-18 x 2" Lg. . . .	6
*30	O-Ring .....	1	154	Soc. Set Screw, #10-24 x 1/2" Lg	
*31	Oil Seal .....	1		(Vertical Down Brakes Only) .....	2
*32	Wear Sleeve .....	1	156	Stud - Collet Locking, 1/2"-13 .....	1
*34	O-Ring .....	6	158	Dowel Pin, 1/4" Dia. x 2" Lg. ....	1
*35	Oil Seal .....	1	168	1/2" Lockwasher .....	1
*36	Compression Spring		180	Key .....	1
	20 and 30 Ft. Lbs. Torque .....	2			
	45 Ft. Lbs. Torque .....	3			
	60 Ft. Lbs. Torque .....	4			
	90 Ft. Lbs. Torque .....	6			

\* - Indicates parts in Minor Overhaul Kit.

\*\* - Indicates parts in Major Overhaul Kit. (This Major Overhaul Kit also includes all parts in the Minor Overhaul Kit.)

See **Section 2** for actual Brake Stack Assembly Configurations.

## Posistop MB-210 and MB-210L COUPLER BRAKE

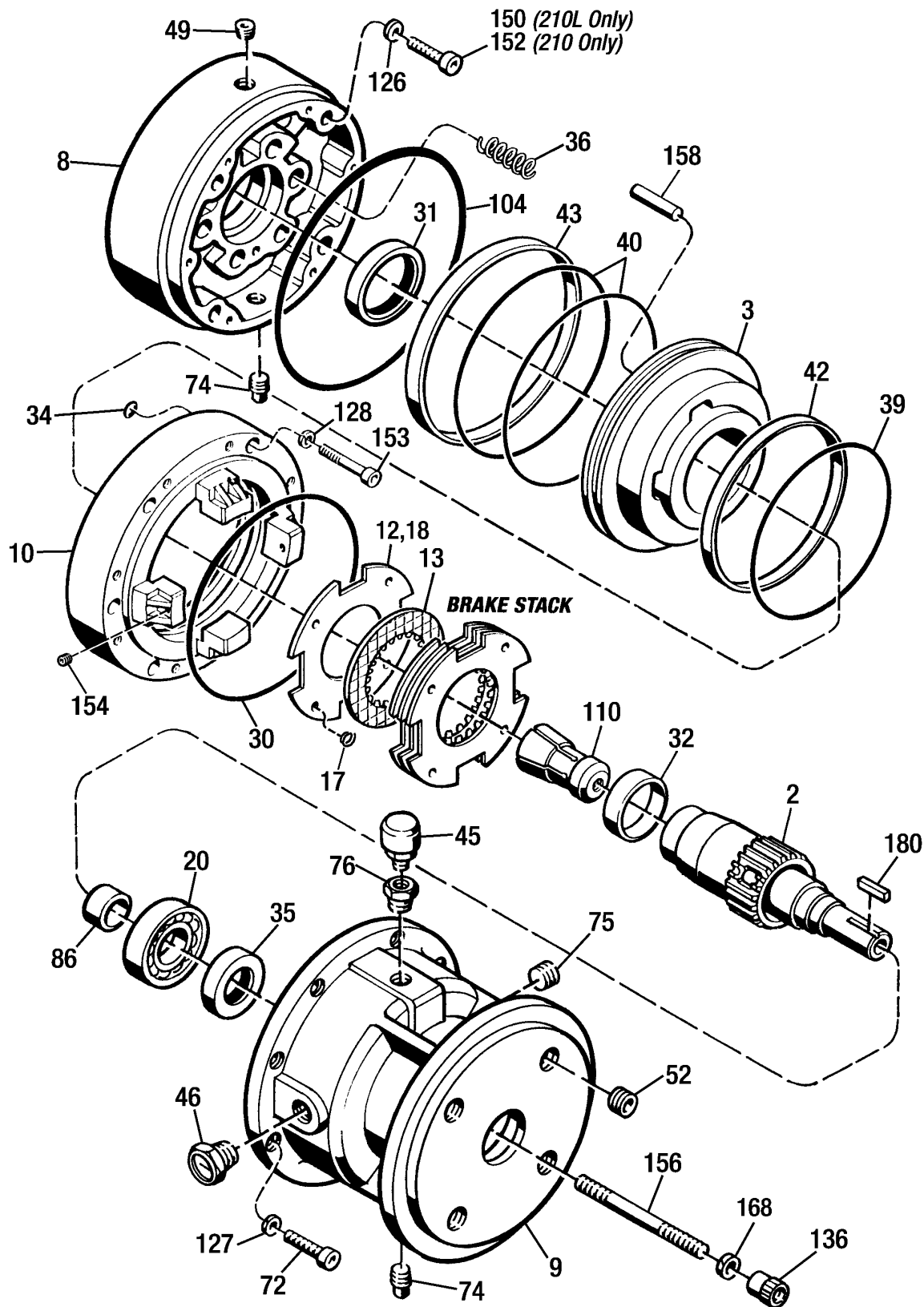

Figure 10.1 - MB-210 and MB-210L Coupler Brake

**FORCE CONTROL INDUSTRIES, INC.**



MEX (55) 53 63 23 31 MTY (81) 83 54 10 18  
 QRO (442) 1 95 72 60 ventas@industrialmagza.com

**Repair Parts List (Figure 10.2)**  
**Posistop MB-250, MB-280 & MB-320 COUPLER BRAKE**

REF No.	PART NAME	QTY.	REF No.	PART NAME	QTY.
2	Hub	1	*39	O-Ring	1
3	Piston	1	*40	O-Ring	2
8	Housing	1	*42	Liner, I.D. Sealing	1
9	End Housing	1	*43	Liner, O.D. Sealing	1
10	Piston Housing	1	**45	Air Breather	1
11	Piston Retainer	1	**46	Sight Gauge	1
*12	Drive Plate		67	Pipe Cap, 1/8" NPT	1
	<i>(Horizontal Brakes)</i>		72	Soc. Hd. Cap Screw, 3/8"-16 x 1-1/4" Lg	16
	"K" Stack Configuration	7	73	Pipe Plug, 1/8" NPT	1
	All other Stack Configurations	6	74	Pipe Plug, Mag. 1/4" NPT, Sq. Hd.	1
	<i>(Vertical Brakes)</i>		75	Pipe Plug, 1/2" NPT	1
	"KV" Stack Configuration	3	76	Reducer Bushing, 1/2" x 1/4"	1
	All other Stack Configurations	1	77	Pipe Nipple, 1/8"NPT x 2" lg.	1
*13	Friction Disc		86	Wear Sleeve	1
	"K" & "KV" Stack Configurations	4	*104	O-Ring	1
	All other Stack Configurations	5	110	Collet, Taper	1
*17	Separator Springs <i>(Vertical Brakes Only)</i>		113	Key	1
	"KV" Stack Configuration	16	127	Lockwasher, 3/8"	16
	All other Stack Configurations	20	128	Lockwasher, 1/2"	4
*18	Drive Plate, w/ Rivets <i>(Vertical Brakes Only)</i>		129	Lockwasher, 3/8"	8
	"KV" Stack Configuration	4	135	Hex Nut, 5/8"11 <i>(MB-280 &amp; 320)</i>	4
	All other Stack Configurations	5	150	Hex. Hd. Screw,	
*20	Ball Bearing	1		1/2"-13 x 2-1/4" Lg. <i>(MB-250)</i>	4
*30	O-Ring	2		5/8"-11 x 2-1/2" Lg.	4
*31	Oil Seal	1	151	Hex. Hd. Screw, 3/8"-16 x 1-1/4" Lg.	8
*32	Wear Sleeve	1	154	Soc. Set Screw, #10-24 x 1/2" Lg.	
*33	O-Ring	1		<i>(Vertical Down Brakes Only)</i>	2
*35	Oil Seal	1	156	Stud - Collet Locking, 5/8"-11	1
*36	Compression Spring		168	Lockwasher, 5/8"	1
	<b><i>(MB-250 and MB-280)</i></b>				
	75 Ft. Lbs. Torque	2			
	150 Ft. Lbs. Torque	4			
	225 Ft. Lbs. Torque	6			
	300 Ft. Lbs. Torque	8			
	<b><i>(MB-320)</i></b>				
	120 Ft. Lbs. Torque	3			
	150 Ft. Lbs. Torque	3			
	200 Ft. Lbs. Torque	4			
	300 Ft. Lbs. Torque	6			
	450 Ft. Lbs Torque	9			

\* - Indicates parts in Minor Overhaul Kit.

\*\* - Indicates parts in Major Overhaul Kit. (This Major Overhaul Kit also includes all parts in the Minor Overhaul Kit.)

See **Section 2** for actual Stack Assembly Configuration.

# Posistop MB-250, MB-280 & MB-320 COUPLER BRAKE

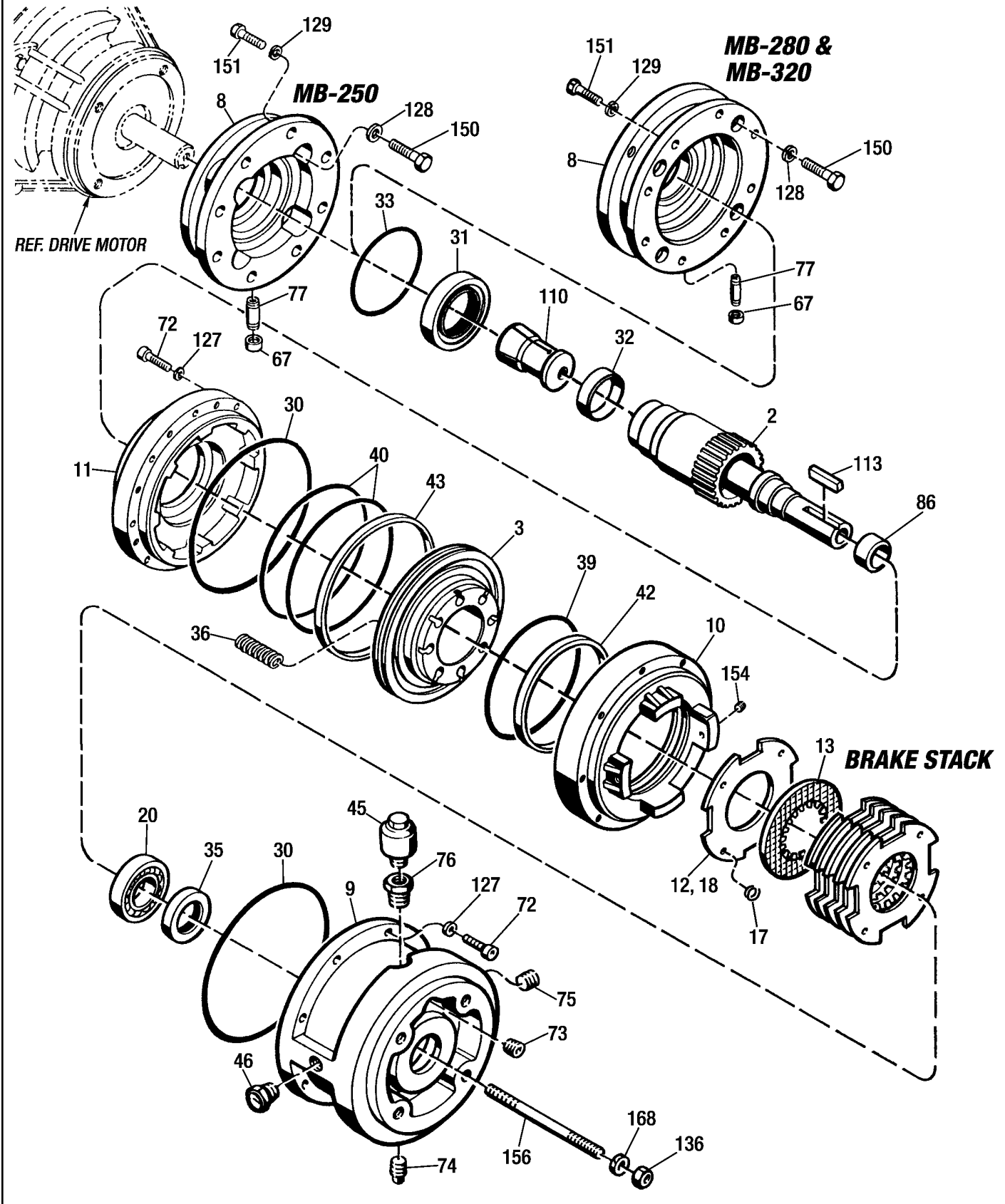

Figure 10.2 - MB-250, MB-280 and MB-320 Coupler Brake

**FORCE CONTROL INDUSTRIES, INC.**



MEX (55) 53 63 23 31 MTY (81) 83 54 10 18  
 QRO (442) 1 95 72 60 ventas@industrialmagza.com

**Repair Parts List (Figure 10.3)**  
**PNEUMATIC CONTROL VALVE MOUNTING KIT**

REF No.	PART NAME	QTY.	REF No.	PART NAME	QTY.
270	Control Valve .....	1	276	Hose .....	1
271	Mounting Bracket .....	1	277	Hose Fitting .....	1
272	Soc. Hd. Cap Screw, 1/4"-20 x 1-1/2" Lg. .	2	278	Hose Fitting .....	1
273	Soc. Hd. Cap Screw (MB-210, 210L) 5/16"-18 x 2" Lg. ....	2	280	90° Swivel Elbow .....	1
	(MB-250, 280 & 320) 3/8"-16 x 2" Lg. ...	2	281	Street Elbow (MB-210, 210L) 1/8" .....	1
274	Lockwasher, 1/4" .....	2		(MB-250, 280 & 320) 1/4" .....	1
275	Lockwasher (MB-210, 210L) 5/16" .....	2	282	Muffler .....	1
	(MB-250, 280 & 320) 3/8" .....	2			

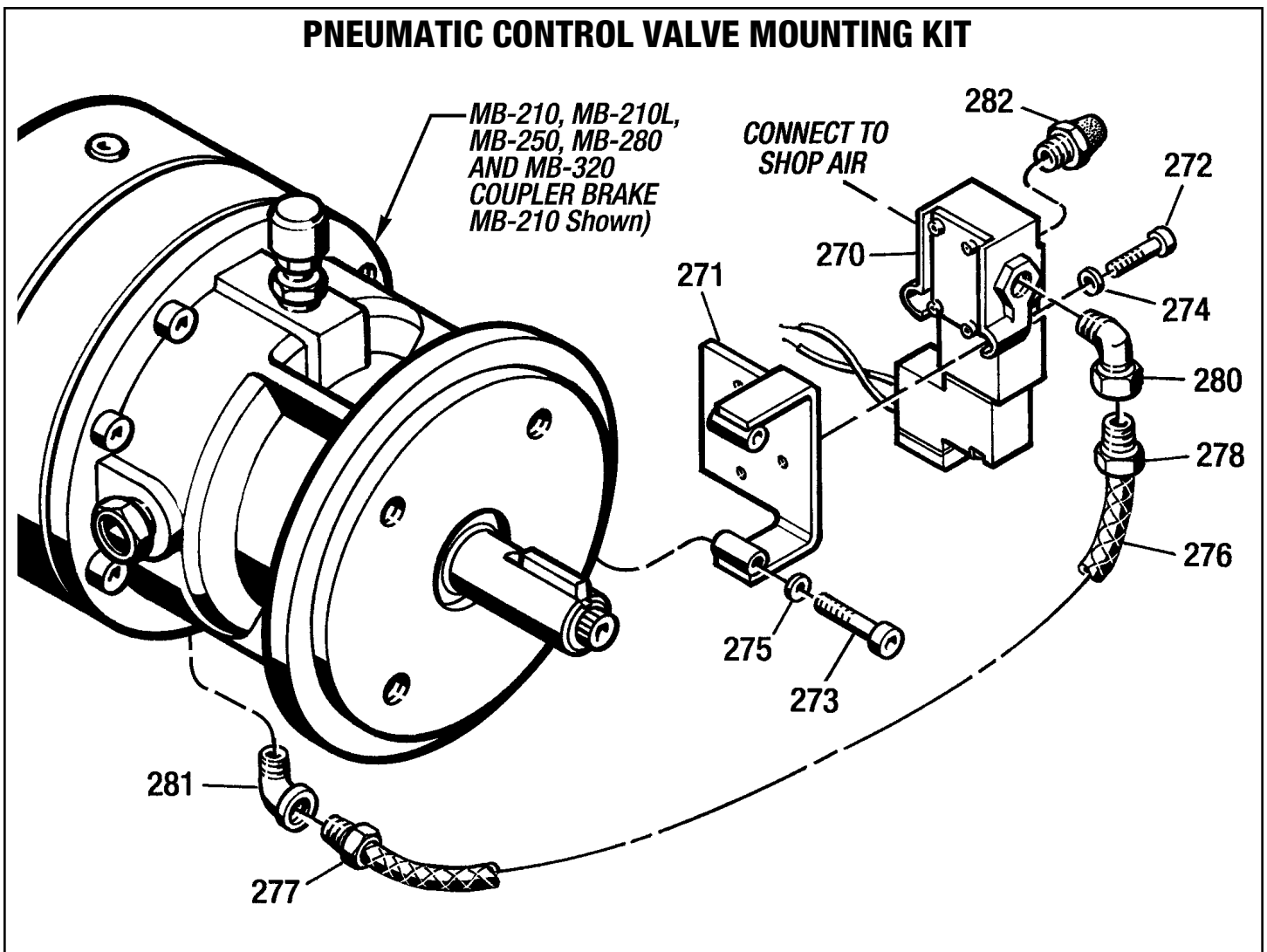
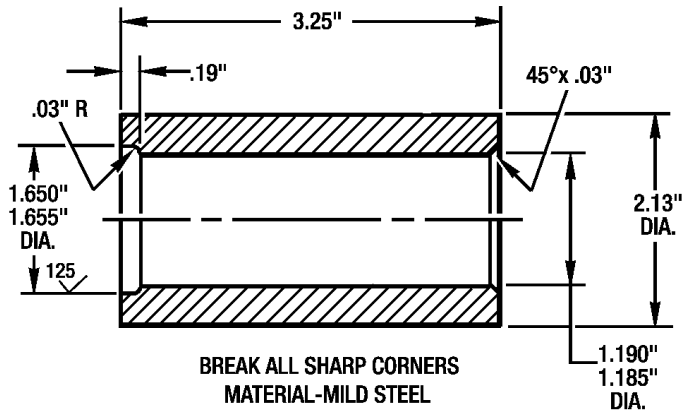
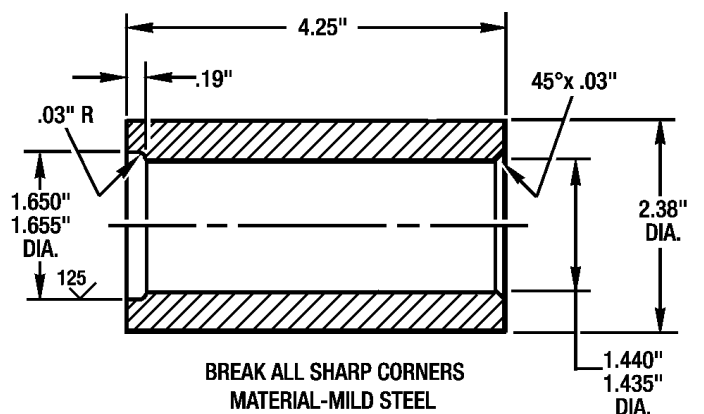

Figure 10.3 - Pneumatic Control Valve Mounting Kit

## DIMENSIONS FOR WEAR SLEEVE ASSEMBLY TOOLS



**WEAR SLEEVE ASSEMBLY TOOL #601-13-048**  
(1-1/8" Dia. Output Shaft)



**WEAR SLEEVE ASSEMBLY TOOL #601-13-049**  
(1-3/8" Dia. Output Shaft)

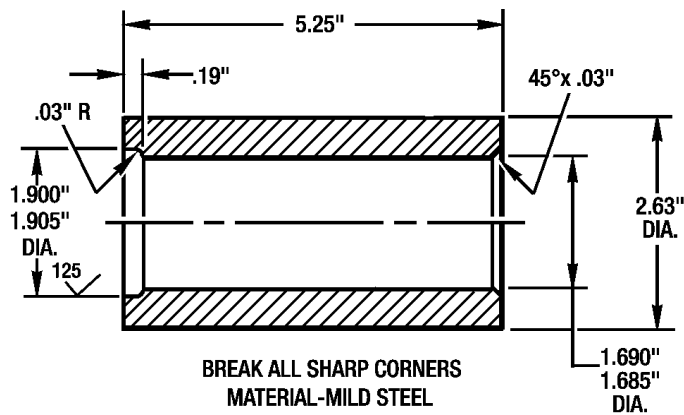

**WEAR SLEEVE ASSEMBLY TOOL #601-16-003**  
(1-5/8" Dia. Output Shaft)

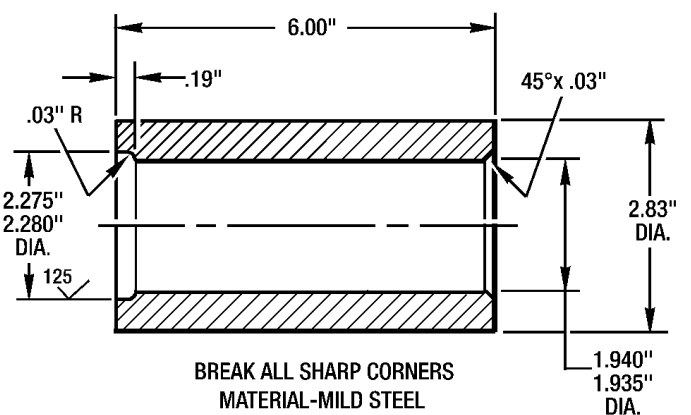

**WEAR SLEEVE ASSEMBLY TOOL #601-17-006**  
(1-7/8" Dia. Output Shaft)

# **FORCE CONTROL INDUSTRIES, INC.**

***Worldwide Leader in “Oil Shear” Product Design.***

*Providing today's industries  
with Oil Shear Clutch and  
Brake Drives that deliver...*

● *Flexibility* ● *Performance*  
*and* ● *Dependability*

---

---

**“BUILT TO LAST - GUARANTEED TO PERFORM”**

---

---



## **FORCE CONTROL INDUSTRIES, INC.**

### **MAIN OFFICE**

P.O. Box 18366  
Fairfield, Ohio 45018

3660 Dixie Highway  
Fairfield, Ohio 45014

Tel: (513) 868-0900  
Fax: (513) 868-2105

E Mail: [info@forcecontrol.com](mailto:info@forcecontrol.com)  
Web Page: [www.forcecontrol.com](http://www.forcecontrol.com)