

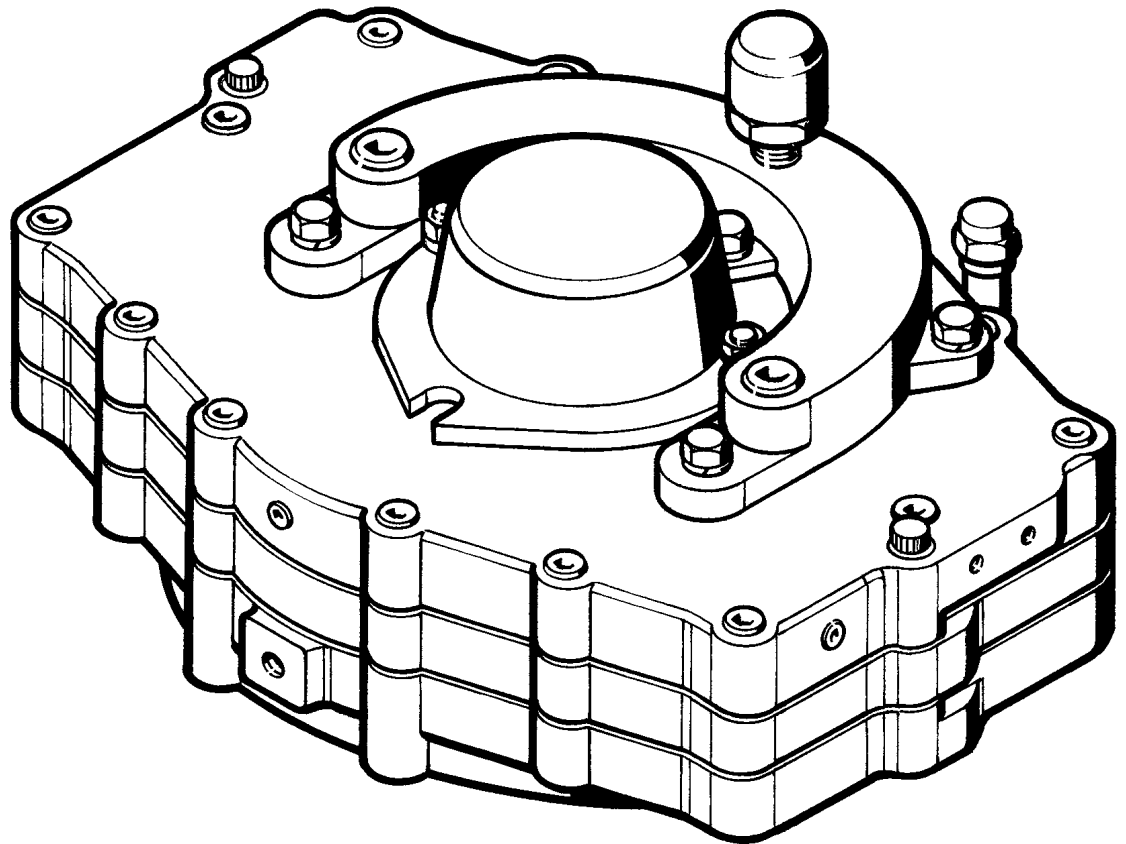

502-CPB-001-02

SERVICE MANUAL AND REPAIR PARTS FOR *Posistop Curing Press Brake*



WARNING - Read this manual before any installation, maintenance or operation.



FORCE CONTROL INDUSTRIES, Inc.

**MANUFACTURERS OF MECHANICAL AND
ELECTRICAL POWER TRANSMISSION EQUIPMENT**



MEX (55) 53 63 23 31 MTY (81) 83 54 10 18
QRO (442) 1 95 72 60 ventas@industrialmagza.com

Limited Warranty

Force Control Industries, Inc. ("Force Control") warrants its products to be free from defects in material and workmanship under normal and proper use for a period of one year from the date of shipment. Any products purchased from Force Control that upon inspection at Force Control's factory prove to be defective as a result of normal use during the one year period will be repaired or replaced (at Force Controls'option) without any charge for parts or labor. This limited warranty shall be void in regard to (1) any product or part thereof which has been altered or repaired by a buyer without Force Control's previous written consent or (2) any product or part thereof that has been subjected to unusual electrical, physical or mechanical stress, or upon which the original identification marks have been removed or altered. Transportation charges for shipping any product or part thereof that the buyer claims is covered by this limited warranty shall be paid by the buyer. If Force Control determines that any product or part thereof should be repaired or replaced under the terms of this limited warranty it will pay for shipping the repaired or replaced product or part thereof back to the buyer. EXCEPT FOR THE EXPRESS WARRANTY SET OUT ABOVE, FORCE CONTROL DOES NOT GRANT ANY WARRANTIES EITHER EXPRESSED OR IMPLIED, INCLUDING IMPLIED WARRANTIES OF MERCHANTABILITY OR FITNESS FOR USE. The warranty obligation set forth above is in lieu of all obligations or liabilities of Force Control for any damages. Force Control specifically shall not be liable for any costs incurred by the buyer in disconnecting or re-installing any product or part thereof repaired or replace under the limited warranty set out above. FORCE CONTROL EXPRESSLY EXCLUDES ALL LIABILITY FOR ANY INDIRECT OR CONSEQUENTIAL DAMAGES THE BUYER MAY SUSTAIN IN CONNECTION WITH THE DELIVERY, USE, OR PERFORMANCE OF FORCE CONTROL PRODUCTS. Under no circumstances shall any liability for which Force Control is held responsible exceed the selling price to the buyer of the Force Control products that are proven to be defective. This limited warranty may be modified only in writing signed by a duly authorized officer of the company. This limited warranty applies exclusively to Force Control products; warranties for motors and gear reducers and other component parts may be provided by their respective manufactures. Any legal action for breach of any Force Control warranty must be commenced within one year of the date on which the breach is or should have been discovered.

A Return Goods Authorization (RGA) number must be obtained from the factory and clearly marked on the outside of the package before any equipment will be accepted for warranty work. Force Control will pay the shipping costs of returning the owner parts that are covered by warranty.

Force Control believes that the information in this document is accurate. The document has been carefully reviewed for technical accuracy. In the event that technical or typographical errors exist, Force Control reserves the right to make changes to subsequent editions of this document without prior notice to holders of this edition. The reader should consult Force Control if errors are suspected. In no event shall Force Control be liable for any damages arising out of or related to this document or the information contained in it.

Size 10 Curing Press Motor Brake

TABLE OF CONTENTS

<p>Section 1 - DESCRIPTION AND OPERATION</p> <p>1-1 The Oil Shear Principle.....1</p> <p>1-2 Curing Press Motor Brake Description and Typical Application.....1</p> <p>1-3 Curing Press Motor Brake Features.....1</p> <p>1-4 Curing Press Motor Brake Operation2</p> <p>Section 2 - SPECIFICATIONS</p> <p>2-1 Dimensional Specifications3</p> <p>2-2 Torque Specifications.....3</p> <p>Section 3 - INSTALLATION</p> <p>3-1 Disassembly Prior to Installation4</p> <p>3-2 Initial Mounting and Alignment of the Brake to the Drive Motor4</p> <p style="padding-left: 20px;"><i>Step 1</i> - Locating the Hub4</p> <p style="padding-left: 20px;"><i>Step 2</i> - Shaft and Mounting Face Runout.....5</p> <p>3-3 Final Installation Procedure5</p> <p>Section 4 - LUBRICATION</p> <p>4-1 Checking the Oil Level6</p> <p>4-2 Changing the Oil.....6</p> <p style="padding-left: 20px;">A. Vertical Mounted Brakes6</p> <p style="padding-left: 20px;">B. Horizontal Mounted Brakes6</p> <p>4-3 Type of Oil6</p> <p>Section 5 - OPERATIONAL CHECKS</p> <p>5-1 Brake Operational Checks7</p> <p>Section 6 - TROUBLE SHOOTING</p> <p>6-1 Trouble Shooting Chart.....8</p> <p>Section 7 - DISASSEMBLY</p> <p>7-1 Initial Disassembly Procedure9</p> <p>7-2 Removing the Brake Stack9</p> <p>7-3 Removing Piston Seals10</p> <p>7-4 Pistons and Thrust Plate Disassembly10</p> <p>7-5 Removing Wear Sleeves and Oil Seals11</p>	<p>Section 8 - CLEANING AND INSPECTION</p> <p>8-1 Cleaning and Inspection11</p> <p>8-2 Repair and Replacement.....11</p> <p>Section 9 - REASSEMBLY</p> <p>9-1 General Reassembly Instructions12</p> <p>9-2 Installing Oil Seals (#31)12</p> <p>9-3 Installing Wear Sleeves (#32)</p> <p style="padding-left: 20px;">A. Installing Top Wear Sleeve (#32).....12</p> <p style="padding-left: 20px;">B. Installing Bottom Wear Sleeve (#32).....13</p> <p>9-4 Installing Hub (#2) and Input Housing (#7) to the Drive Motor13</p> <p>9-5 Installing Piston Housing (#10)13</p> <p>9-6 Installing Brake Stack14</p> <p>9-7 Thrust Plate and Piston Reassembly.....14</p> <p>9-8 Installing Brake Springs (#36) and End Housing (#9)15</p> <p>Section 10 - ILLUSTRATED PARTS LIST</p> <p>10-1 General Information.....16</p> <p>10-2 Factory Rebuild Service.....16</p> <p>10-3 Ordering Replacement Parts16</p> <p>10-4 Name Plate Information.....16</p> <p>10-5 Model Number Information17</p> <p>Repair Parts List18</p> <p>Figure 10.1 - Curing Press Brake Repair Parts.....19</p>
--	--

Section 1

DESCRIPTION AND OPERATION

1-1 THE OIL SHEAR PRINCIPLE

Conventional clutches and brakes depend on the friction between solid surfaces operating in air to transmit torque. Friction does the job, but produces a great amount of **Heat and Wear**, causing an increase in replacement parts, break-down and maintenance time.

Oil Shear Technology was pioneered by **Force Control** in 1959 and resulted in one of the most energy efficient Brake/Clutch Variable Drive Systems available today.

In 1970 **Force Control** introduced an integral Oil Pump, which requires no additional parts. The oil pump forces a positive oil feed from the center of the brake disc stack to "Float" the friction surfaces in a continuously circulating bath of oil.

The oil molecules tend to cling to each other and also the the friction surfaces. As moving and stationary surfaces are brought together, a thin but positive film of oil is maintained between them and is controlled by the clamping pressure and grooves designed into the braking surfaces.

Torque is transmitted from one surface to the other through the viscous shear of the oil film. The braking surfaces are protected by this oil film, which reduces wear and also effectively transmits heat away from the braking surfaces.

...thus brake wear is greatly reduced along with all routine maintenance common to conventional dry motor brakes.

1-2 CURING PRESS MOTOR BRAKE DESCRIPTION AND TYPICAL APPLICATION

(See Figure 1.1)

The Posistop Curing Press Motor Brake is a multiple surface, spring set and pneumatic release motor brake that was designed specifically for the tire manufacturing plants that produces consumer tires.

The Curing Press has hot molds to shape and vulcanize the tire. A brake motor rotates the mold mechanism from a fully closed position to a fully open position and back. The purpose of this **Posistop Curing Press Motor Brake** is to provide a positive means of stopping the mold in either the open or closed position. The closed position is very critical. The mold needs to close at

FORCE CONTROL INDUSTRIES, INC.

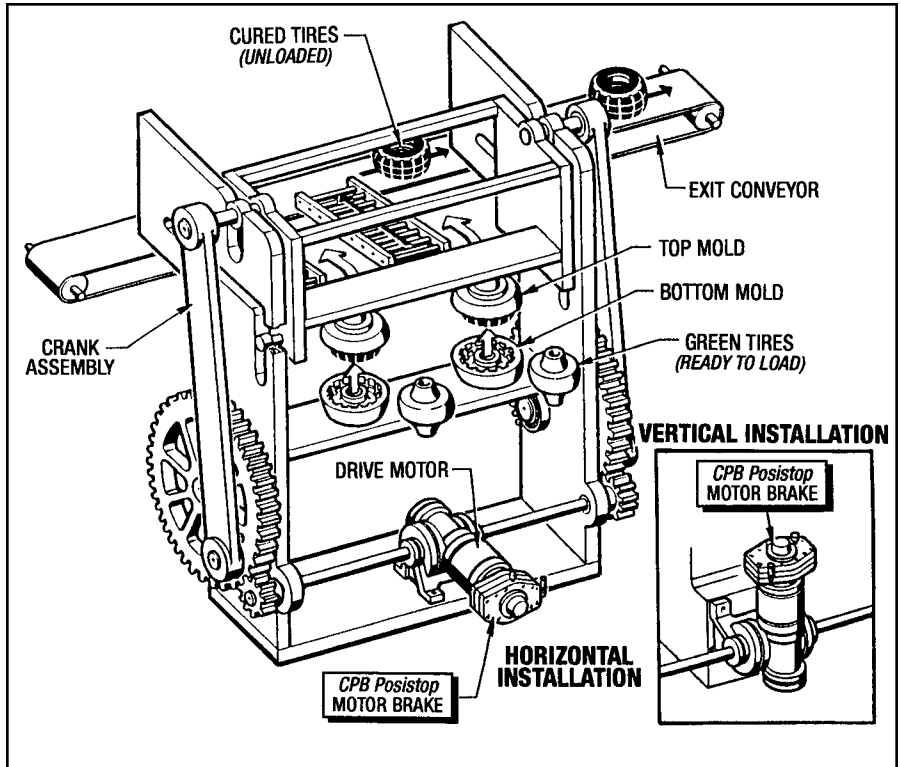

Figure 1.1 - Tire Curing Press

exactly the right moment or the mold can become damaged.

1-3 CURING PRESS MOTOR BRAKE FEATURES

The most important Feature is the fact that it will reduce maintenance time and provide a very long service life.

- Easy retro-fit on existing machinery.
- Totally enclosed design prevents contamination and corrosion.
- Heavy-duty housings combined with precision machined parts guarantee performance.
- Self adjusting, maintenance free.
- Internal integral oil pump to maintain the **Oil Shear Principle**.
- Multiple surface brake stack which distributes the braking torque along the whole hub rather than on a single braking surface, reducing the heat and wear on each braking surface.
- 48 Ft. Lbs. to 145 Ft. Lbs. braking torque.
- 7-1/4" Dia. or 9" Dia. mounting bolt circle.
- Vertical or horizontal mounting.

1-4 CURING PRESS MOTOR BRAKE OPERATION

The Curing Press Motor Brake Cross Section (Figure 1.2) shows the brake in the normally spring set braked position.

Compressed air, controlled by an external pneumatic control valve, enters the piston chambers which moves the (4) pistons to disengage the brake stack, allowing the drive motor to rotate freely.

When the air is released the (4) pistons, which are spring loaded, returns to the braking position.

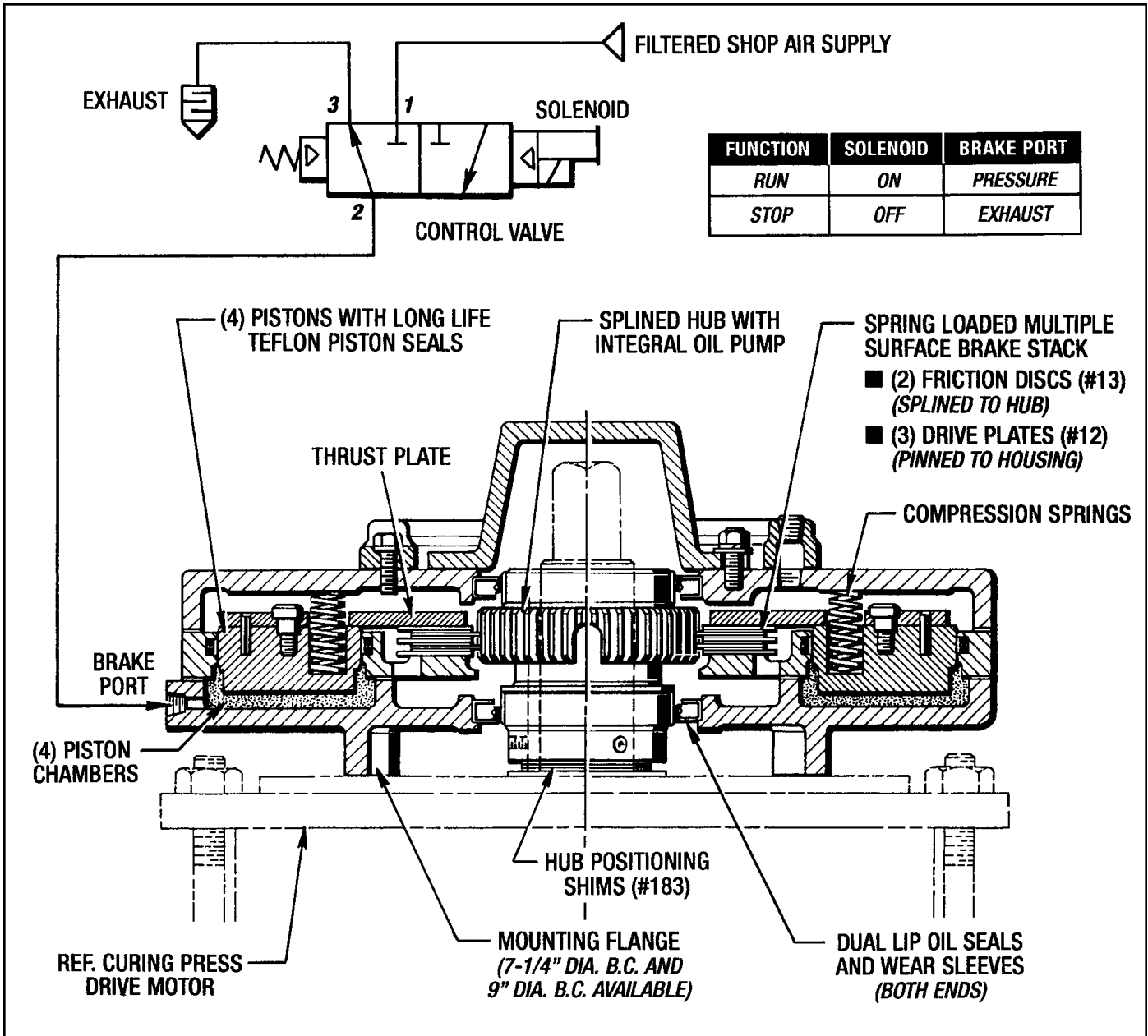
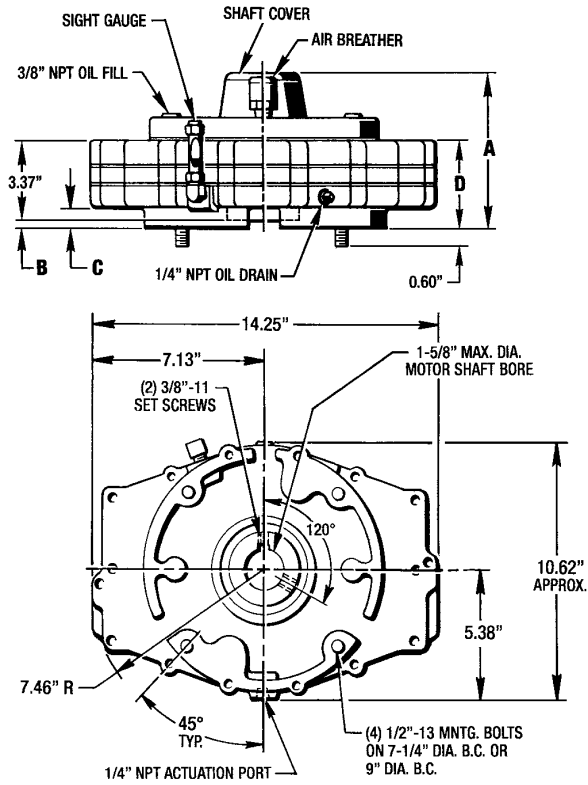

Figure 1.2 - Curing Press Brake Section

Section 2 SPECIFICATIONS

2-1 DIMENSIONAL SPECIFICATIONS

VERTICAL INSTALLATION



DIA. B.C.	DIMENSION (Inches)			
	A	B	C	D
7.25"	6.24	0.25	0.87	3.63
9.00"	6.12	0.12	0.75	3.50

HORIZONTAL INSTALLATION

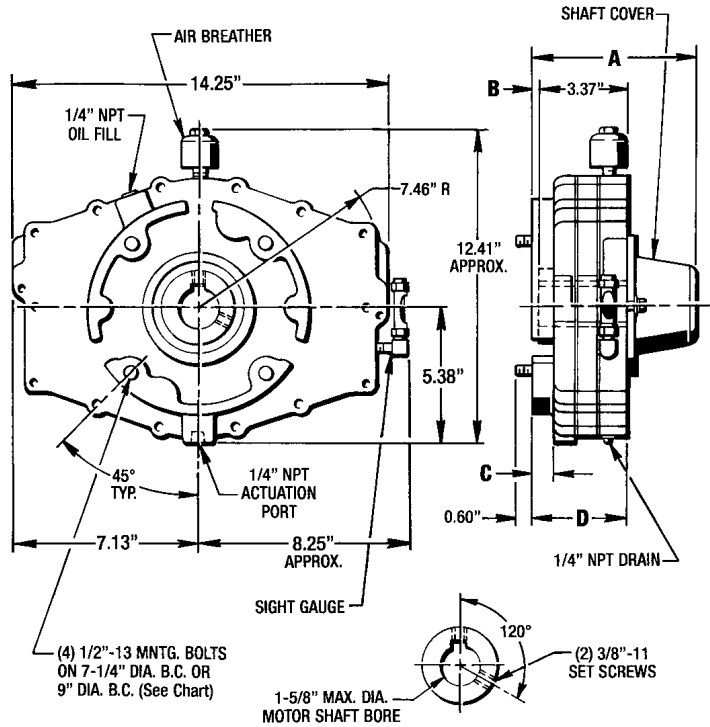

DIA. B.C.	DIMENSION (Inches)			
	A	B	C	D
7.25"	6.24	0.25	0.81	3.63
9.00"	6.12	0.12	0.69	3.50

2-2 - TORQUE SPECIFICATIONS

STATIC TORQUE (Ft. Lbs.)	DYNAMIC TORQUE (Ft. Lbs.)	MINIMUM PRESSURE TO RELEASE (PSI)	CYCLIC WK ² (Lb. Ft. ²)	MAX KE PER ENGMT. (Ft. Lbs.)	PISTON VOLUME (Cu. Ins.)
48	42	24	.0465	7,400	12
75	65	35			
95	82	47			
120	104	60			
145	126	70			

Max. Operating Speed - 1800 RPM

Approx. Fluid Capacity - 1 Quart

FORCE CONTROL INDUSTRIES, INC.



MEX (55) 53 63 23 31 MTY (81) 83 54 10 18
 QRO (442) 1 95 72 60 ventas@industrialmagza.com

SECTION 3 INSTALLATION

IMPORTANT SAFETY PRECAUTIONS

The Curing Press Motor Brake described in this manual must not be installed in any manner except as specified and must not be operated at speeds, torque loads or temperatures other than those specified. Failure to limit operation of the brake to the conditions specified could damage the unit and may cause malfunction or damage to interconnecting equipment.

WARNING

The following precautions must be taken if the installation of the Curing Press Motor Brake is to be a retrofit for an existing application. Before attempting installation, open the motor disconnect, shut off the control electrical supply and lock them out to avoid any possibility of personal injury. Be sure that any mechanisms holding inclined or vertical loads are locked mechanically with cribbing or other means.

The Curing Press Motor Brake is partially pre-assembled at the factory for ease of shipment and installation.

The Brake is also shipped dry with no oil in it. The oil will have to be added after installation.

The Breather (#44) and Sight Gauge (#46) may be shipped loose with red plastic plugs installed in the holes. These plugs will have to be removed at a later time. If the Breather (#44) and Sight Gauge (#46) is installed they will not have any pipe dope on the threads. Remove them so they won't get damaged.

The Gasket (#121) will also be shipped loose.

The Hub (#2) and Shims (#183) plus the mounting screws and seal washers will also be shipped loose.

NOTE - There will be (4) Screws (#152) and (4) Brass Washers (#81) for a 7-1/4" Dia. B.C. If you have a 9" Dia. B.C. there will be (4) Screws (#152), (2) Brass Washers (#81) and (2) Lock Washers (#167).

The Brake will have to be partially disassembled to install it on to the Curing Press Drive Motor.

3-1 DISASSEMBLY PRIOR TO INSTALLATION

(See Figure 10.1 for a visual reference to all parts.)

1. Remove the (14) Screws (#149) and (14) Lockwashers (#127) from the top of the End Housing (#9).
2. Remove the Breather (#44) and the Sight Gauge (#46), if they are still installed so they don't get damaged in the Installation Procedure.

3. Remove the (2) 3/8" NPT Pipe Plugs (#73) in the top of the brake.

NOTE - These (2) Pipe Plugs (#73) are located in the top of the End Housing (#9) for Horizontal Brakes and they are located in the top of the Oil Shroud (#224) for Vertical Brakes.

4. Insert an allen wrench in the (2) pipe tap holes and back-out the (2) 3/8"-16 Soc. Hd. Screws (#153) that holds the Piston Housing (#10) to the Input Housing (#10).

NOTE - It is not recommended that these (2) Screws (#153) be completely removed because the (2) Lockwashers (#128) can fall off when the screws are lifted out. Just back them out enough so the screw threads are free from the Input Housing (#7).

5. Carefully lift the End Housing (#9) and Piston Housing (#10) Sub-Assembly straight up and off the Input Housing (#7).
6. Set this Sub-Assembly on a flat surface with the Shaft Cover (#212) pointed up. Remove this Shaft Cover (#212) from the top of the End Housing (#9) and set it aside.

3-2 INITIAL MOUNTING AND ALIGNMENT OF THE BRAKE TO THE DRIVE MOTOR

(See Figure 3.1)

Make sure the motor shaft and motor mounting surface is clean and free of any nicks or burrs. Lightly coat the motor shaft with white lithium grease before any further installation.

A special **Assembly Tool (#601-CPB-001)** needs to be used to correctly position the Hub (#2) on to the Drive Motor Shaft and to correctly align and mount the Input Housing (#7) to the motor face. This Assembly Tool is not furnished with your Curing Press Motor Brake, but can be ordered from **Force Control** with the Part Number **#601-CPB-001**. The procedure is as follows:

Step #1 - Locating the Hub

1. Place enough Hub Shims (#183) on the motor shaft so there is a gap under the Assembly Tool as shown in Figure 3.1. **The Maximum Gap is .060"**.

NOTE - If the gap is large enough for a Hub Shim (#183) to fit between the Assembly Tool and the motor mounting surface then remove (1) Hub Shim (#183) from the motor shaft..

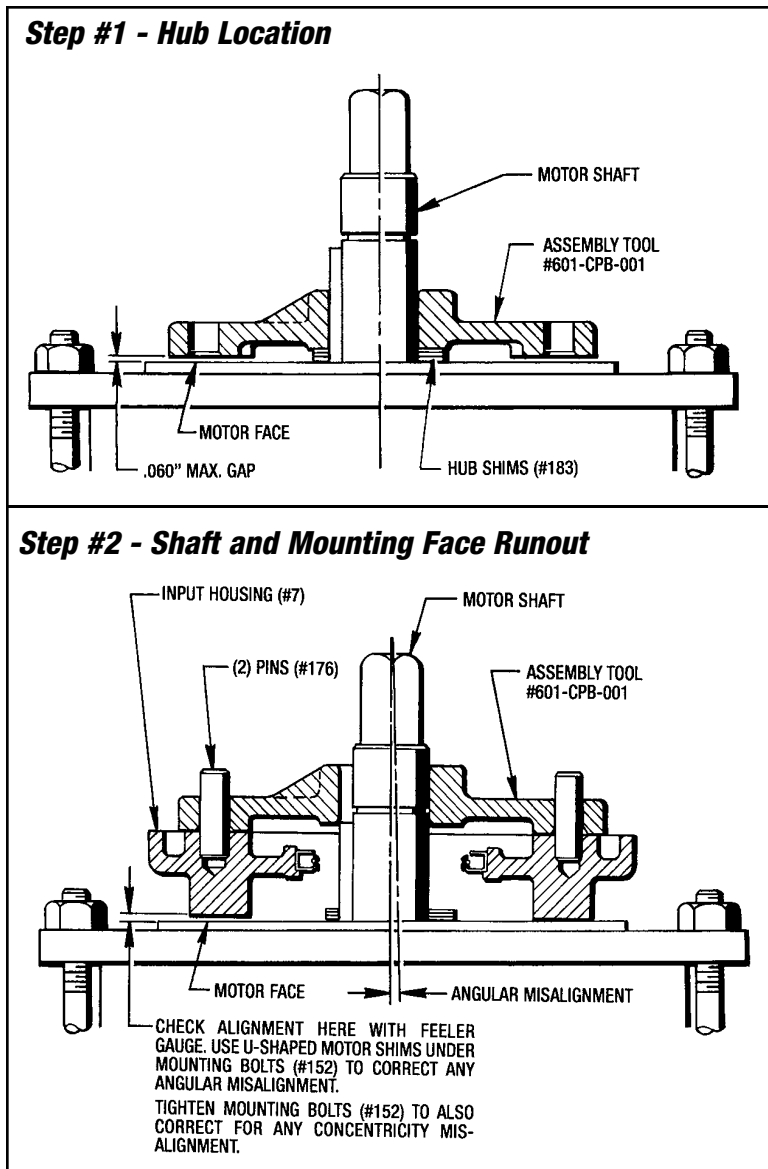

Figure 3.1 - Curing Press Motor Brake Installation

Step #2 - Shaft and Mounting Face Runout

1. Place the **Assembly Tool #601-CPB-001** over the (2) Dowel Pins (#176) until it rests on the Input Housing (#7) as shown in Figure 3.1.
2. Place both the Input Housing (#7) and Assembly Tool on to the motor mounting face and motor shaft. **Do not attach at this time.**
3. Using a feeler gauge, check the angular alignment between the Input Housing (#7) and the motor mounting surface. Use U-Shaped Motor Shims, which are not furnished, to correct any angular misalignment.
4. Install the mounting screws, brass washers and lock-washers. Use **Red Loctite #271** only on the screws that have brass washers under the head. Tighten down and torque to **60 Ft. Lbs.**

NOTE - There will be (4) Screws (#152) and (4) Brass Washers (#81) for a 7-1/4" Dia. B. C.

There will be (4) Screws (#152), (2) Brass Washers (#81) and (2) Lock Washers (#167) for a 9" Dia. B.C.

Tightening these mounting screws will also automatically correct any concentricity misalignment.

5. Remove Assembly Tool from the motor shaft.
6. Lightly coat the lip of the bottom Oil Seal (#31) which is in the bore of the Input Housing (#7) and the Wear Sleeve (#32) on the Hub (#2) with oil or vaseline.

CAUTION - Make sure that the (2) Set Screws (#108) located in the Hub (#2) are not backed out too far. They will damage the lip on the Oil Seal (#31) if they are sticking out too far.

7. Carefully slide the Hub (#2) onto the motor shaft and into the bottom Oil Seal (#31) until it rests on the Hub Shims (#183). **Be very careful not to damage the oil seal lip.**

8. Tighten the (2) Set Screws (#108) in the Hub (#2). **Use Blue Loctite #242 and torque to 25 Ft. Lbs.**

NOTE - There are (3) openings in the bottom flange for access to these (2) set screws.

3-3 FINAL INSTALLATION PROCEDURE

(See Figure 10.1)

1. Position the Gasket (#121) on the top mounting face of the Input Housing (#7). Use the (2) Pins (#158) for alignment **Apply Permatex 30 to both sides of this gasket.**

2. Lightly coat the lip of the top Oil Seal (#31) which is in the bore of the End Housing (#9) and the top Wear Sleeve (#32) located on the Hub (#2) with oil or vaseline.
3. With the overhead hoist, carefully lower the End Housing (#9) and Piston Housing (#10) Sub-Assembly into position over the Hub (#2) and on to the Input Housing (#7). **Be very careful not to damage the lip of the Oil Seal (#31) located in the End Housing (#9).**

NOTES:

- a. Make sure the spline on the Hub (#2) is aligned with the splines in the Friction Discs (#13). Use a barring tool to align the motor shaft and hub spline with the friction disc splines.
- b. Also make sure the (2) Dowel Pins (#176) sticking up out of the Input Housing (#7) align up with the holes in the Drive Plates (#12).

- c. With a flash light check through the (2) 3/8" NPT holes in the top of the End Housing (#9) or the Oil Shroud (#224) to see if the (2) Screws (#153) and (2) Lockwashers (#128) are in place.
- d. Finally make sure that when the Sub-Assembly is lowered into place that the Gasket (#121) remains in place.
4. Insert an allen wrench through the (2) 3/8" NPT holes and tighten the (2) Screws (#153). **Torque to 25 Ft. Lbs.**
 5. Install the (14) Screws (#149) and (14) Lockwashers into the End Housing (#9). **Torque to 25 Ft. Lbs.**
 6. Attach the Shaft Cover (#224) to the top of the End Housing (#9) with (2) Set Screws (#155), (2) Lockwashers (#129), (2) Flat Washers (#193) and (2) Hex Nuts (#135).

Before going any further make an Operational Check as described in Section 5 to make sure the (4) Pistons (#3) are operating properly.

7. Replace the Air Breather (#44) into the top of the brake, the Elbow (#220) and the Sight Gauge (#46) into the Input Housing (#7). Use pipe dope on the threads.
8. Fill your Curing Press Motor Brake with oil as described in **Section 4 - Lubrication**.
9. Replace the (2) Pipe Plugs (#73) into the top of the End Housing (#9) or the Oil Shroud (#224).

This completes the Installation Procedure and your Curing Press Motor Brake is ready for service.

Section 4 LUBRICATION

4-1 CHECKING THE OIL LEVEL

(See Figure 4.1)

Check the oil level when the brake is initially installed and weekly thereafter or until experience dictates otherwise. Always check the oil with the brake stationary (not running). The oil level is to be as shown in Figure 4.1.

4-2 CHANGING THE OIL

(See Figure 4.1)

IMPORTANT - Always open the disconnects to the drive motor and lock them out before changing the oil.

Completely change the oil in your brake every 3 months. Change the oil more frequently in harsh environments or high cyclic applications.

A. Vertical Mounted Brakes

1. Remove the Pipe Plug (#64) and drain the oil from the brake. Replace this plug when all of the oil is drained out.
2. Remove the Pipe Plug (#268) located in the Street Elbow (#132) in the side of the End Housing (#9).
3. Fill the brake to the proper level as shown in Figure 4.1.

CAUTION - Do not overfill the brake. Excess oil will cause the brake to overheat.

B. Horizontal Mounted Brakes

1. Remove the Pipe Plug (#64) and drain the oil from the brake. Replace this plug when all of the oil is drained out.
2. Remove one of the Pipe Plugs (#73) located in the top of the End Housing (#9).
3. Fill the brake to the proper level as shown in Figure 4.1.

CAUTION - Do not overfill the brake. Excess oil will cause the brake to overheat.

4-3 TYPE OF OIL

Use only Mobil Automatic Transmission Fluid ATF-210 (Type "F") or Mobil Multi-purpose Automatic Transmission Fluid.

Other fluids may be used for special applications.

Always use the type of fluid specified on the Name Plate. If the Name Plate is missing or there is any doubt about the proper fluid to use contact Force Control Industries, Inc.

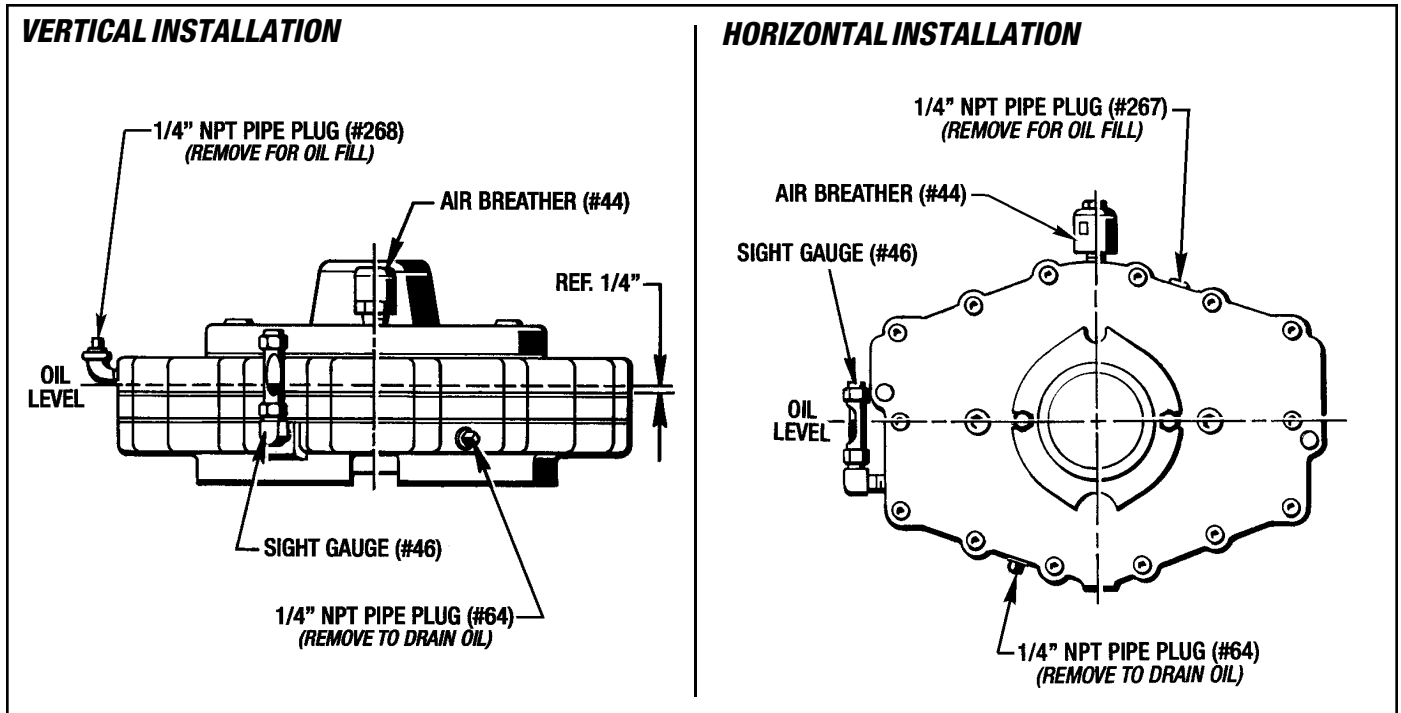

Figure 4.1 - Lubrication

Section 5 OPERATIONAL CHECKS

CAUTION - Make these Operational Checks only when the brake is shut down. Open the motor disconnects and lock them out to avoid any personal injury.

5-1 BRAKE OPERATIONAL CHECKS

Provisions for manual operation is to be made if the brake has been removed for repair. Set up a temporary manually controlled air supply with a quick-acting shut-off valve and a pressure gauge. (See Figure 5.1)

1. Apply the air pressure to the brake and quickly shut the air off. Observe the pressure gauge to see if there is a significant pressure drop.

If there is a pressure drop of 5 PSI or more within a 30 Second time, the brake is not operating correctly.

This would indicate that the piston seals or gaskets are worn or damaged and would need to be replaced.

2. Exhaust the air pressure and attempt to manually turn the hub. The hub should be locked in position. If the hub can be turned then the pistons did not return to the normal brake position.

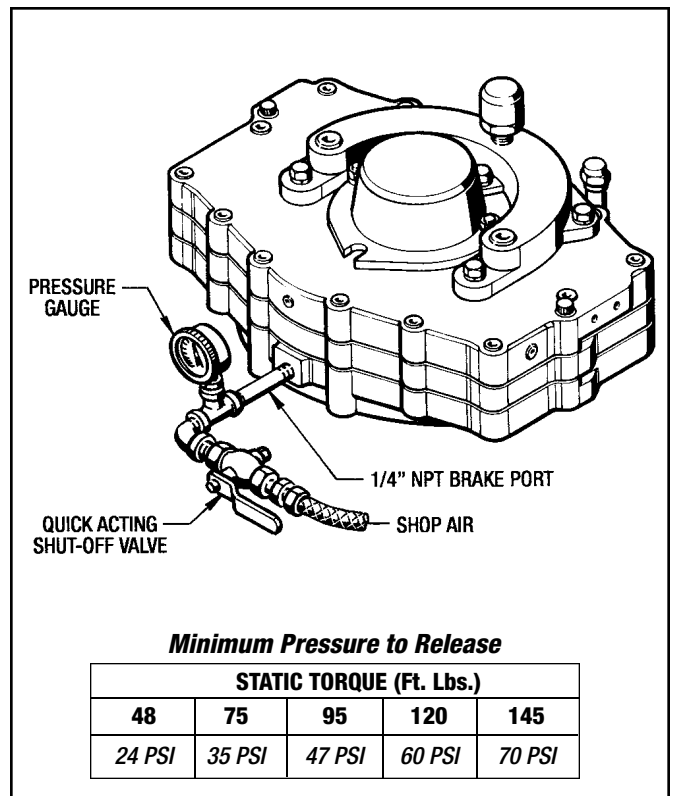

Figure 5.1 - Pneumatic Set-Up for Operational Checks

FORCE CONTROL INDUSTRIES, INC.



MEX (55) 53 63 23 31 MTY (81) 83 54 10 18
 QRO (442) 1 95 72 60 ventas@industrialmagza.com

Section 6 TROUBLE SHOOTING

6-1 TROUBLE SHOOTING CHART

TROUBLE	POSSIBLE CAUSE	REMEDY
A. Brake fails to engage properly.	Pistons sticking or binding. Worn Friction Discs. Weak or broken springs. Air pressure not exhausting or slow in exhausting.	Disassemble to the extent necessary and inspect for damaged parts. Replace brake stack. Replace as needed. Check control valve or muffler and clean or replace as necessary.
B. Brake engages too quickly.	Low oil level.	Check oil level and correct.
C. Noise and vibration.	Improper or loose mounting on motor.	Check mounting bolts and alignment. If partial disassembly is required refer to Section 3 - Installation.
D. Brake fails to disengage properly.	Low air pressure. Piston sticking or binding Control valve not functioning properly.	Increase air pressure. (See Section 2) Disassemble to the extent necessary and inspect for damaged parts. Check valve operation and replace if necessary.
E. Brake overheats (Over 225° F.)	Brake not engaging or disengaging properly causing excessive slippage. Improper oil level.	Refer to troubles A and D. Check oil level and correct.
F. Oil leakage.	Oil seal lip or wear sleeve damaged. Bad alignment. External bolts not tight. Gaskets damaged.	Check for oil leaking around shaft. Replace if necessary. Check and correct alignment. Tighten all external bolts. Check and replace if necessary.
G. Oil leakage at breather.	Oil level too high.	Drain excess oil.
H. Brake does not repeat.	Air pressure changed. *Oil temperature changed. Inconsistent stopping signal.	Check and adjust air pressure. Check temperature. Check control circuit.

* - **NOTE:** For installations requiring precise starting and stopping, operating temperatures are very important. Operating temperatures between 116° F. and 165° F. are recommended.

Section 7 DISASSEMBLY

Unless the brake is to be completely overhauled, it should only be disassembled to the extent necessary to gain access to the worn or damaged parts.

An overhead crane and soft sling is recommended for lifting any heavy parts.

WARNING:
Shut-Off and Lock-Out all air and electrical power before attempting to make any repairs to your Curing Press Motor Brake.

See *Figure 10.1* for a visual reference to all parts being disassembled.

7-1 INITIAL DISASSEMBLY PROCEDURE

(See *Figure 10.1*)

1. First drain all the oil from the brake as described in **Section 4 - Lubrication**. Save or discard as condition warrants.
2. Remove the Sight Gauge (#46) and the Air Breather (#44) so they won't get damaged.
3. Disconnect the pneumatic control valve, fittings and hoses that would get in the way of further disassembly.

7-2 REMOVING THE BRAKE STACK

(See *Figure 10.1*)

1. Remove the (2) Hex Nuts (#135), (2) Lockwashers (#129) and (2) Flat Washers (#193) and take the Shaft Cover (#212) off the End Housing (#9).
2. Take the (14) Screws (#149) and (14) Lockwashers (#127) out of the End Housing (#9).

Then carefully remove the remaining (2) Ferry Head Screws (#72) and (2) Lockwashers (#128) from the top of the End Housing (#9).

CAUTION - This End Housing (#9) is under extreme spring pressure so remove these (2) Screws carefully and in an even manner to release the spring pressure.

3. Lift the End Housing (#9) and Gasket (#122) off the Piston Housing (#10). Discard the gasket. (See *Figure 7.1*)
4. Remove the Springs (#36) from the spring pockets in the (4) Pistons (#3). Make a free-hand sketch of spring locations. (*Ref. Figure 9.6*) This will help you at Reassembly.

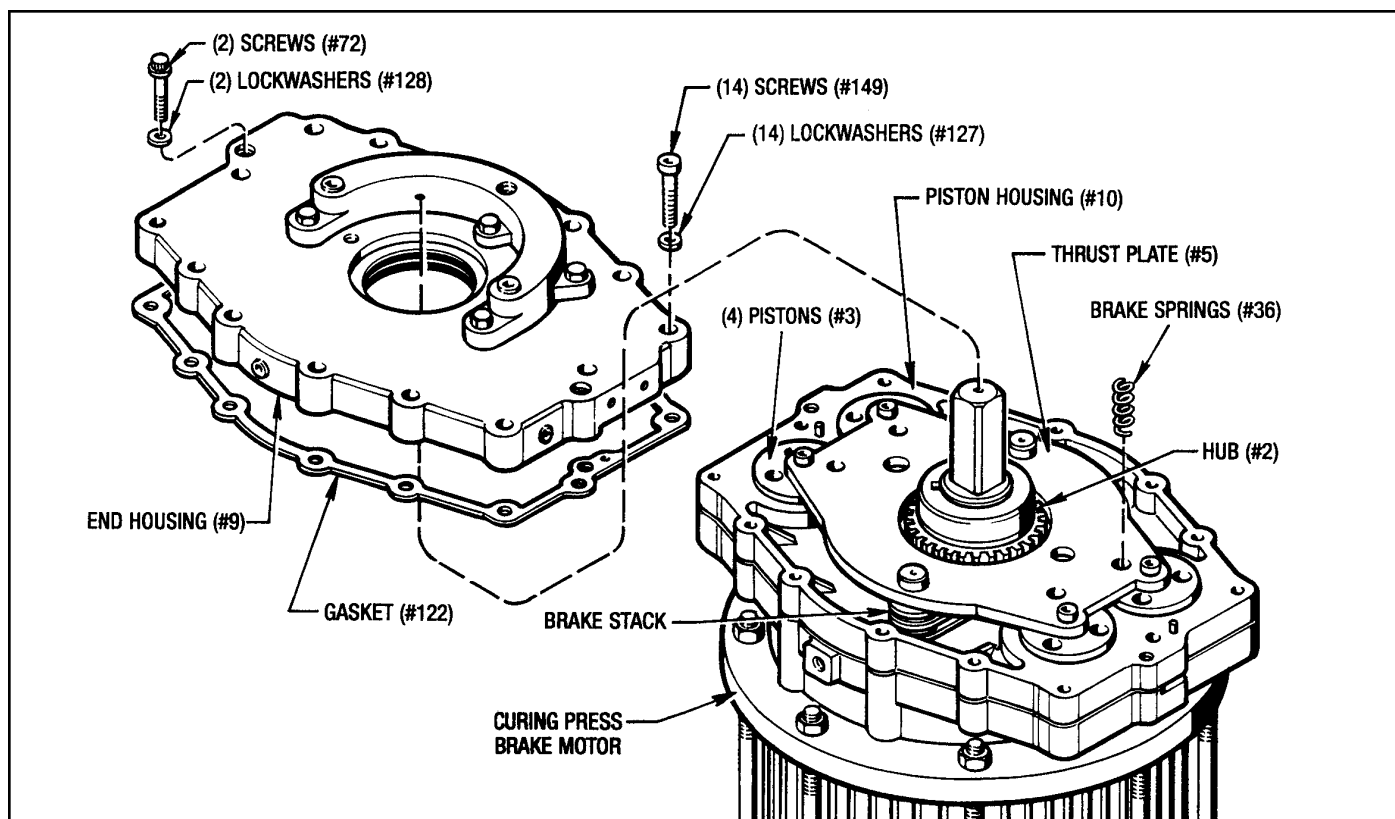

Figure 7.1 - Removing End Housing

FORCE CONTROL INDUSTRIES, INC.



MEX (55) 53 63 23 31 MTY (81) 83 54 10 18
 QRO (442) 1 95 72 60 ventas@industrialmagza.com

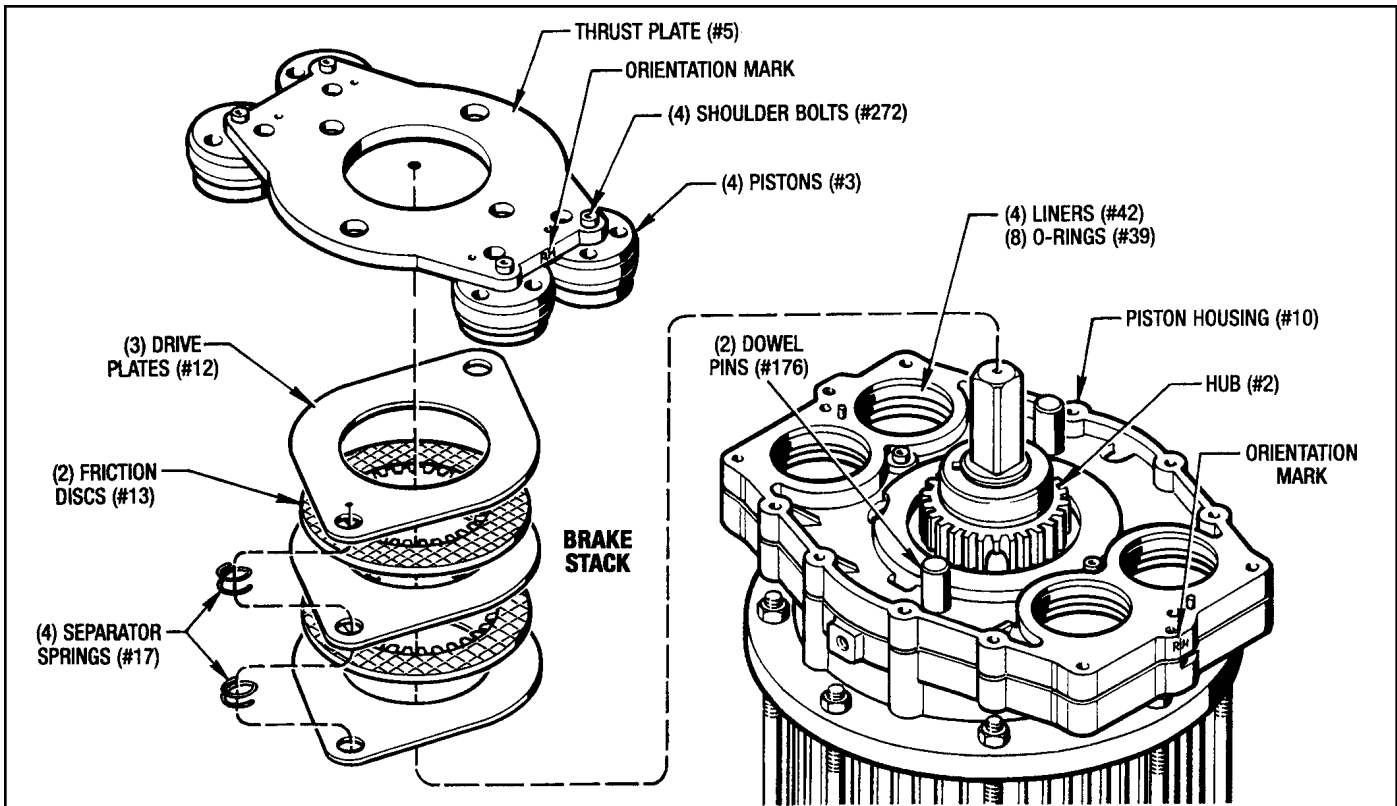

Figure 7.2 - Removing Thrust Plate, Pistons and Brake Stack

5. Pry the Thrust Plate and Piston Sub-Assembly straight up and out of the Piston Housing (#10). Be very careful not to damage the (4) Piston Liners (#42) in each of the piston bores. (See Figure 7.2)

IMPORTANT - Keep this Thrust Plate and Piston Sub-Assembly in the same orientation for reassembly. With a magic marker, mark one of the matching sides of both the Thrust Plate and the Piston Housing to help you at reassembly. (See Figure 7.2)

6. Remove the Brake Stack from the Hub (#2) spline and the (2) Dowel Pins (#176).

NOTE - The Brake Stack will consist of (3) Drive Plates (#12), (2) Friction Discs (#13) and (4) Separator Springs (#17). (See Figure 7.2)

If this is the only repair to be made then jump ahead to Section 9 - Reassembly.

7-3 REMOVING PISTON SEALS

(See Figure 7.3)

1. Remove the (2) Screws (#153) and (2) Lockwashers (#128) from the Piston Housing (#10). Pry the Piston Housing (#10) and Gasket (#121) off the Input Housing (#7). Discard the Gasket.

NOTE: This Piston Housing does not have to be removed to replace the piston seals.

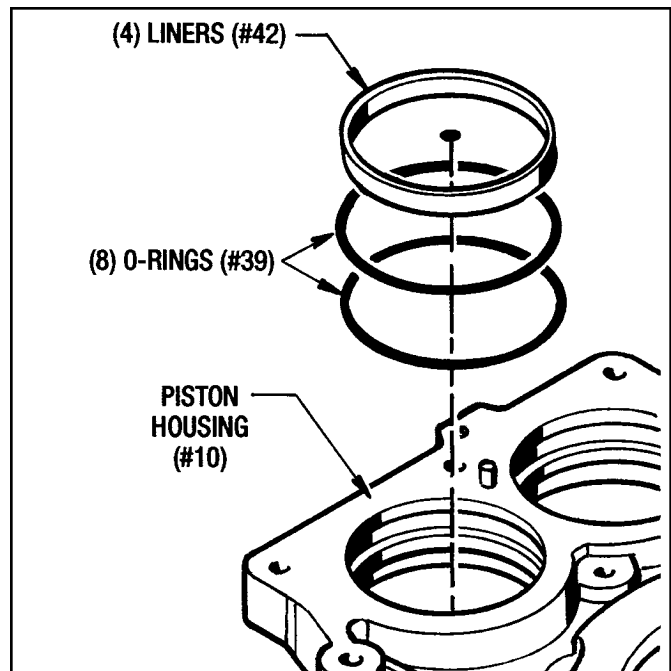

Figure 7.3 - Removing Piston Seals

2. Pry each Piston Liner (#42) and (2) O-Rings (#39) out of each piston bore and discard them.

7-4 PISTONS AND THRUST PLATE DISASSEMBLY

If any of the (4) Pistons (#3) have been damaged and have to be replaced, then use the following disassembly procedure to remove them.

- Each of the (4) Screws (#272) that holds a Piston (#3) to the Thrust Plate (#5) has Loctite #271 on the threads so you will have to use a blow torch first to remove them. **Be sure to use gloves when handling heated parts.**

7-5 REMOVING WEAR SLEEVES AND OIL SEALS

- Loosen the (2) Set Screws (#108) and pull the Hub (#2) straight up and off the motor shaft and out of the bottom Oil Seal (#31). **Be careful not to damage the lip of the Oil Seal (#31).**
- With a chisel the same width as the Wear Sleeve (#32), make about 8 to 10 notches in each Wear Sleeve to be replaced. They can then be removed by hand. (See Figure 7.4)
- The top Oil Seal (#31) can be pressed out of the End Housing (#9) with an arbor press.
- Take the Input Housing (#7) off the drive motor to remove the bottom Oil Seal (#31). The mounting screws have **Red Loctite #271** on them so they will have to be heated up with a blow torch to remove them. **Be sure to use gloves when handling heated parts.** Discard the (2) or (4) Brass Washers under the screw heads. They have to be replaced with new ones at Reassembly.

- Use an arbor press to remove the Oil Seal (#31) from the Input Housing (#9) bore.

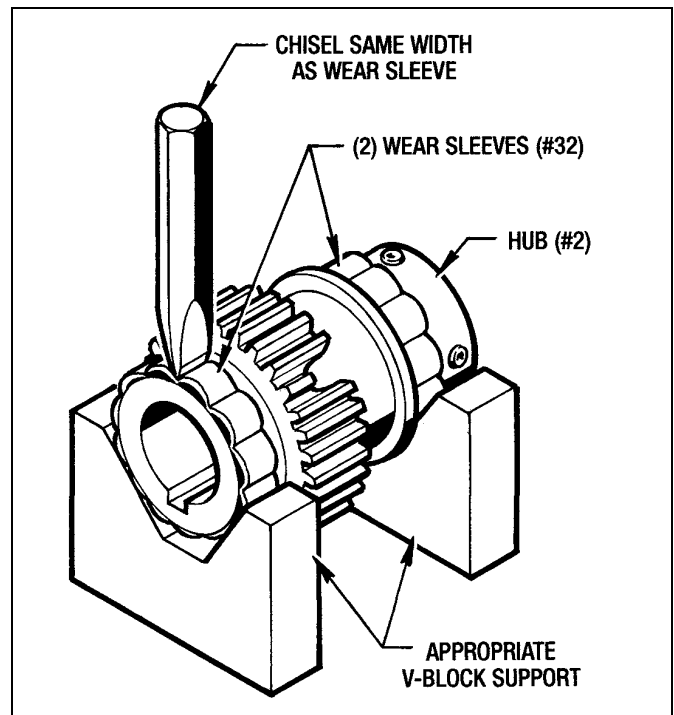

Figure 7.4 - Removing Wear Sleeves (#32)

Section 8 CLEANING AND INSPECTION

8-1 CLEANING AND INSPECTION

Clean metal parts in a suitable solvent and dry in a stream of low pressure compressed air. The Brake Drive Plates (#12) can be cleaned in a solvent, but **DO NOT** clean the Brake Friction Discs (#13) in solvent. Use only a clean, dry and lint-free rag to clean these Friction Discs. (Solvent will damage the resilient paper-based friction material used on the Friction Discs). Keep the Drive Plates and Friction Discs in the same order as they were removed. After cleaning, inspect parts for cracks, distortion, scoring, nicks, burrs or other damage would affect serviceability. Pay particular attention to the following:

- Check the friction disc wear surfaces for scoring, galling or evidence of uneven wear.
- Check the brake drive plates for scoring or galling. Make sure they are flat. If a perceptible ridge is worn in any of the drive plates, replace all of the drive plates and friction discs as a complete set.
- Carefully check the (4) pistons and bore surfaces for nicks, scratches, scoring or other damage which would affect operation or cause leakage.

- Carefully check the (4) Piston Liners (#42) and the (8) O-Rings (#39) for wear or any condition that would cause leakage.
- Pay particular attention to the (2) Wear Sleeves (#32) located on the Hub (#2) and the (2) Oil Seals (#31). Check for nicks or scratches which would cause leakage. Replace any damaged parts.

8-2 REPAIR AND REPLACEMENT

A fine stone or crocus cloth may be used to remove minor surface defects from parts so long as the operating or sealing action of the part is not affected. The use of coarser abrasives or other machining methods should not be attempted. Otherwise, damaged parts should be replaced.

Replacement is recommended also for the following, as applicable:

- Replace all O-Rings, Liners, Gaskets and Oil Seals removed during the course of disassembly.
- Replace Brake Friction Discs and Drive Plates in complete sets only.

Section 9 REASSEMBLY

9-1 GENERAL REASSEMBLY INSTRUCTIONS

1. See *Figure 10.1* for a visual reference to all parts being reassembled.
2. Do not use any gasket sealant when installing both Gaskets (#122) and (#123).
3. Apply Copper Coat to both sides of Gasket (#121) when installing it.
4. Lubricate the lips of both Oil Seals (#31), Piston Liners (#42) and O-Rings (#39) with Vaseline (or equivalent) immediately before reassembly and installation of any mating parts. The same oil that is used in the brake can also be used instead of Vaseline.
5. Use **Red Loctite #271** on the Shoulder Screw (#272) and Mounting Screws (#152) that uses a Brass Washer (#81) under the head. **NOTE:** Any screws that uses lockwashers does not require any thread adhesive.

Also use this **Red Loctite #271** for installation of the (2) Wear Sleeves (#32) on the Hub (#2).

Use **Blue Loctite #242** on the (2) Set Screws (#108) that holds the Hub (#2) on the motor shaft.

Clean off any excess adhesive with **Loctite #755 Adhesive Cleaner**.

6. Use **Permatex #30 Gasket Sealant** on the O.D. of the (2) Oil Seals (#31) when installing them.

9-2 INSTALLING OIL SEALS (#31)

(See *Figure 10.1*)

1. First thoroughly clean the oil seal bores in the End Housing (#9) and the Input Housing (#7). **Make sure they are clean and free of any foreign material.**
2. Apply a thin coat of **Permatex #30 Sealant** to the oil seal bores.
3. Press both Oil Seals (#31) into the bores with an arbor press.
4. Clean off any excess Sealant.

9-3 INSTALLING WEAR SLEEVES (#32)

(See *Figure 10.1*)

Make sure that the surfaces of Hub (#2) are thoroughly cleaned before installing either Wear Sleeve (#32).

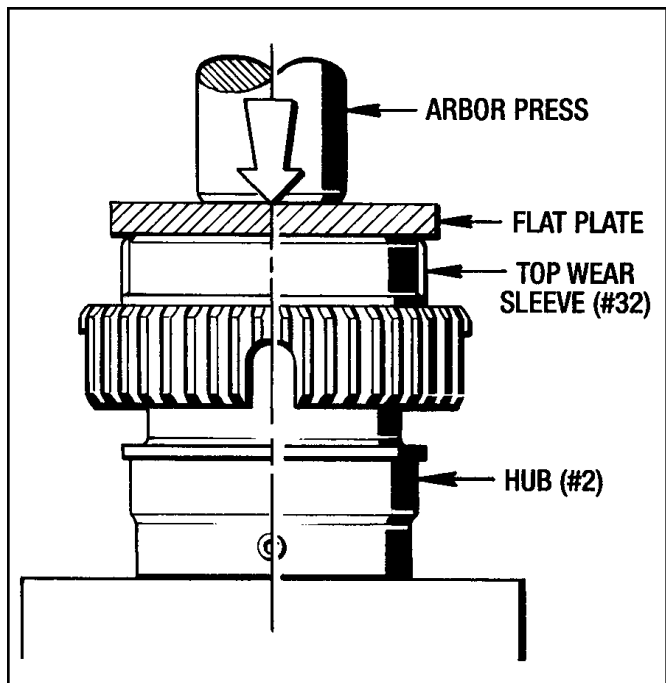

Figure 9.1 - Installing Top Wear Sleeve (#32)

A. Installing Top Wear Sleeve (#32)

1. Apply **Red Loctite #271** to the hub diameter and press the top Wear Sleeve (#32) on to the Hub (#2) with an arbor press as shown in *Figure 9.1*. Clean off any excess adhesive.

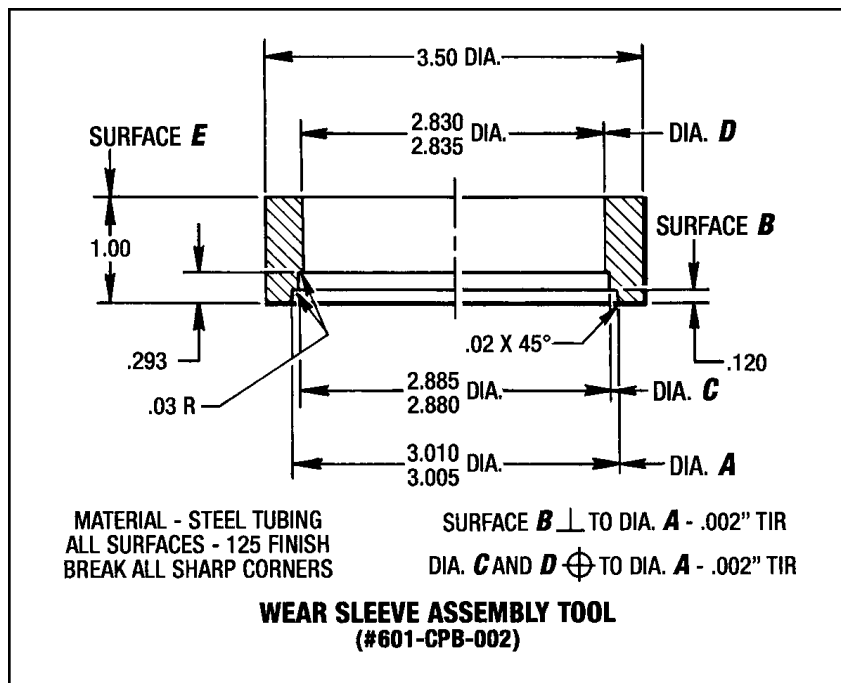

Figure 9.2 - Wear Sleeve Assembly Tool

B. Installing Bottom Wear Sleeve (#32)

A Special Assembly Tool must be used to install this bottom Wear Sleeve (#32) on to the Hub (#2).

Dimensions and Specifications are given in *Figure 9.2* if you prefer to make your own tool. It can also be ordered from **Force Control Industries, Inc.** with the **Part Number #601-CPB-002**.

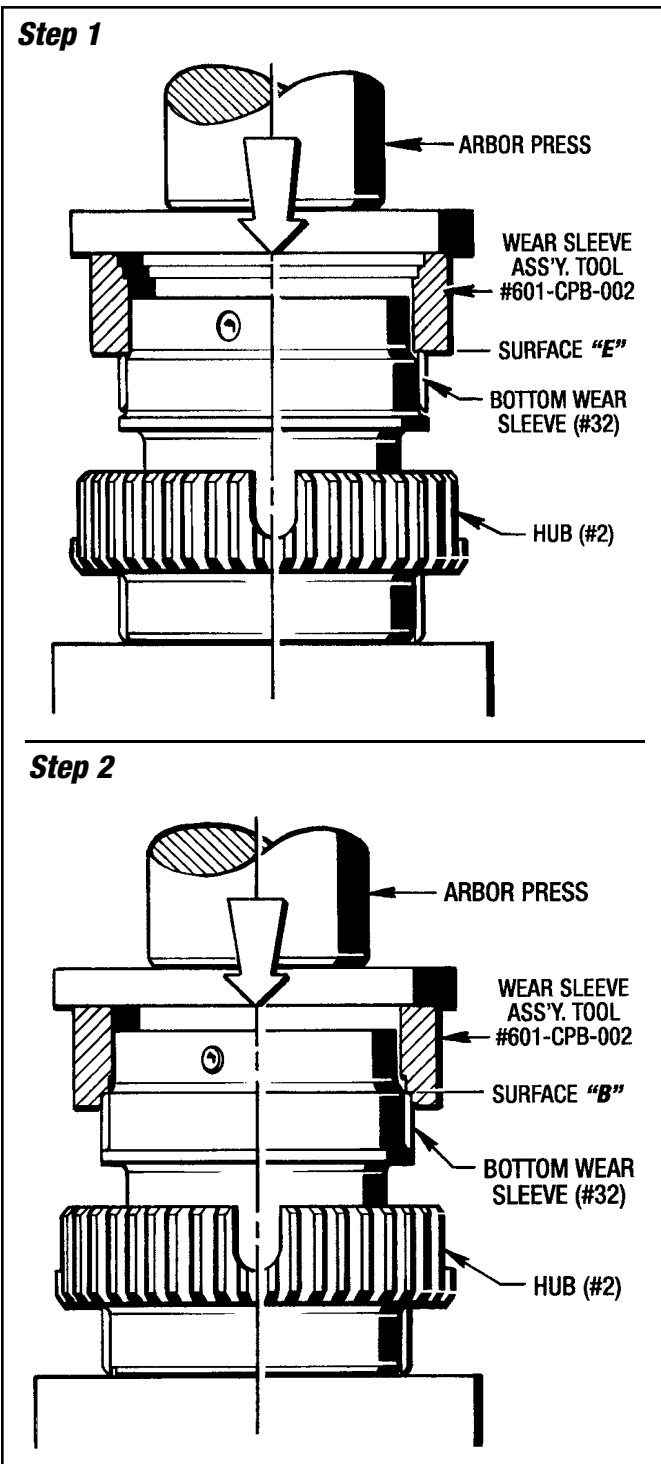

Figure 9.3 - Installing Bottom Wear Sleeve (#32)

1. Apply **Red Loctite #271** to the hub diameter.
2. With an arbor press and the Wear Sleeve Assembly Tool, install the bottom Wear Sleeve (#32) on to the Hub (#2) as shown in *Figure 9.3*.

Step 1 - Using surface "E", press the Wear Sleeve (#32) down on the Hub (#2) as far as it will go. (See *Figure 9.3*.)

Step 2 - Turn the Wear Sleeve Assembly Tool over and with surface "B" finish pressing the Wear Sleeve (#32) down until it is completely seated on the Hub (#2). (See *Figure 9.3*.) **Clean off any excess Loctite.**

9-4 INSTALLING HUB (#2) AND INPUT HOUSING (#7) TO THE DRIVE MOTOR

(See *Figure 10.1*)

Use the exact same procedure as described in **Section 3-2 Initial Mounting and Alignment of the Brake to the Drive Motor** to correctly position the Hub (#2) on the drive motor shaft and to align and mount the Input Housing (#7) to the drive motor. **This complete procedure is given on pages 4 and 5.**

9-5 PISTON HOUSING (#10) REASSEMBLY AND INSTALLATION

(See *Figure 10.1*)

1. Install the (8) O-Rings (#39) and (4) Piston Liners (#42) into the (4) piston bores. (See *Figure 9.4*)

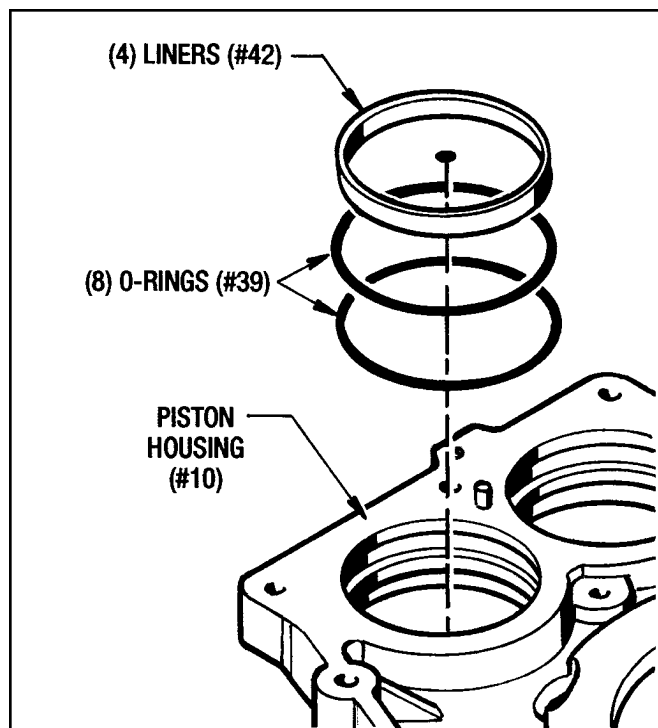

Figure 9.4 - Installing Piston Seals

NOTE - First lubricate the O-Rings and Liners with oil or grease before installing them into the Piston Housing.

2. Position a new Gasket (#121) on the Input Housing (#7). Use the (2) Pins (#158) for alignment. **Use Copper Coat on both sides of the gasket.**
3. Attach the Piston Housing (#10) with (2) Screws (#153) and (2) Lockwashers (#128). **Torque to 25 Ft. Lbs.**

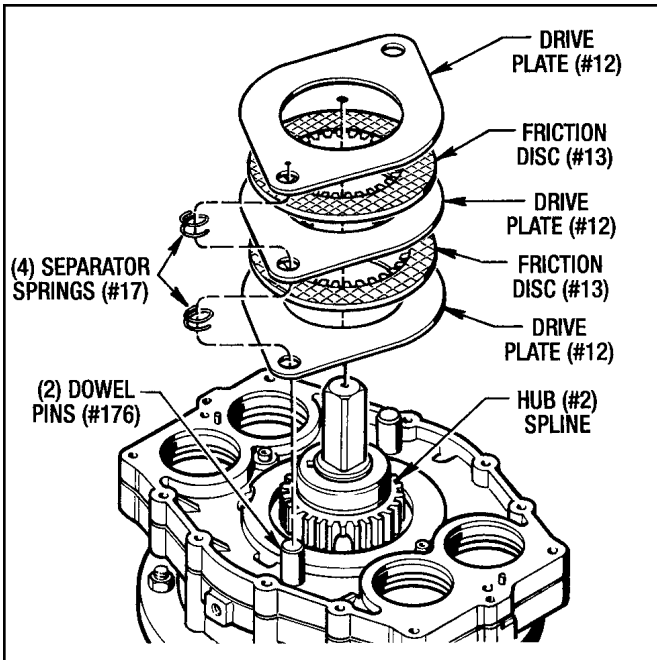

Figure 9.5 - Installing the Brake Stack

9-6 INSTALLING BRAKE STACK

(See Figure 10.1)

1. Install a new Brake Stack on the Hub (#2) spline and the (2) Dowel Pins (#176) as shown in Figure 9.5.

First place a Drive Plate (#12) over the (2) Dowel Pins (#176). Then (2) Separator Springs (#17) and (1) Friction Disc (#13). Another Drive Plate (#12) then (2) more Separator Springs (#17) and (1) more Friction Disc (#13). Last, place (1) more Drive Plate (#12) on the stack.

9-7 THRUST PLATE AND PISTON REASSEMBLY

(See Figure 10.1)

1. If the (4) Pistons (#3) had to be removed from the Thrust Plate (#5) then re-attach the (4) new Pistons (#3) to the Thrust Plate (#5) with (4) Shoulder Screws (#272). **Use Red Loctite #271 and torque to 14 Ft. Lbs.**
2. Insert this Piston Sub-assembly into the Piston Housing (#10) as shown in Figure 7.2. **Be very careful not to damage the (4) Piston Liners (#42) in the piston bores.**

NOTES:

1. Make sure the I.D. of the (4) Liners (#42) and the O.D. of each Piston (#3) is well lubricated with oil or vaseline.
2. Also make sure that the orientation marks on the Thrust Plate (#5) and the Piston Housing (#10), which were made at disassembly, match up with each other. (See Figure 7.2)

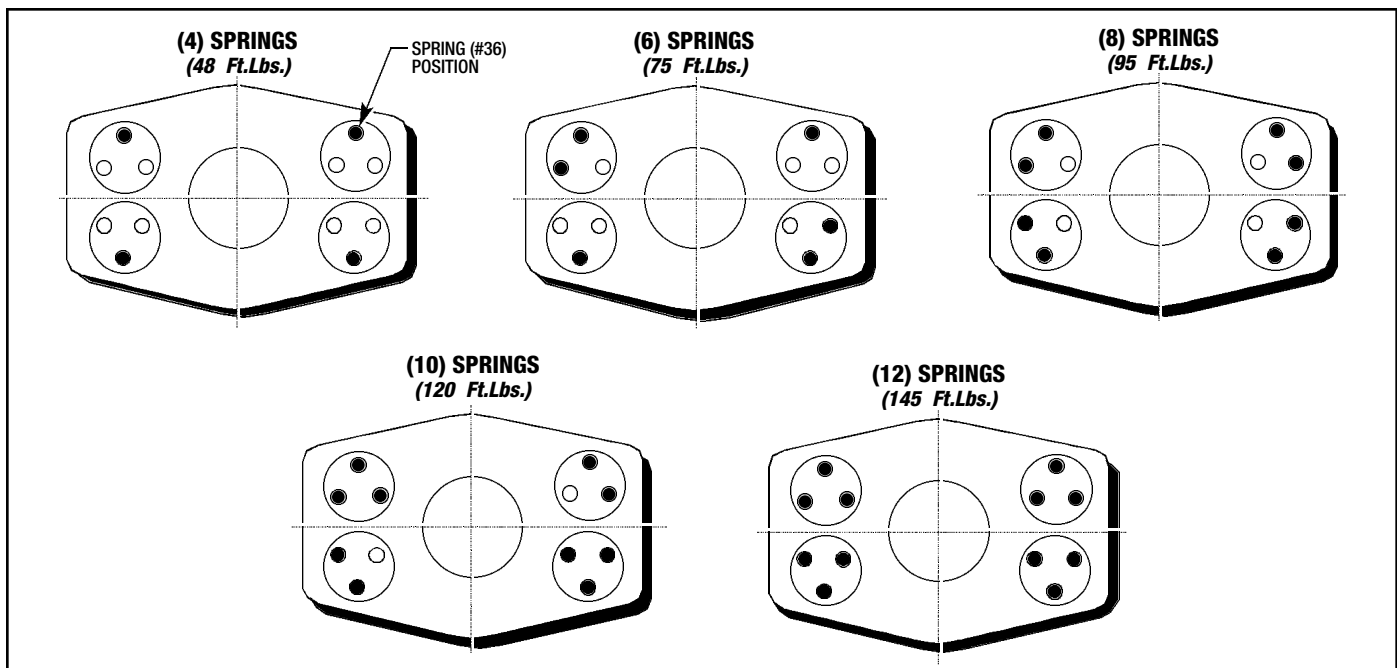

Figure 9.6 - Correct Placement of Springs (#36)

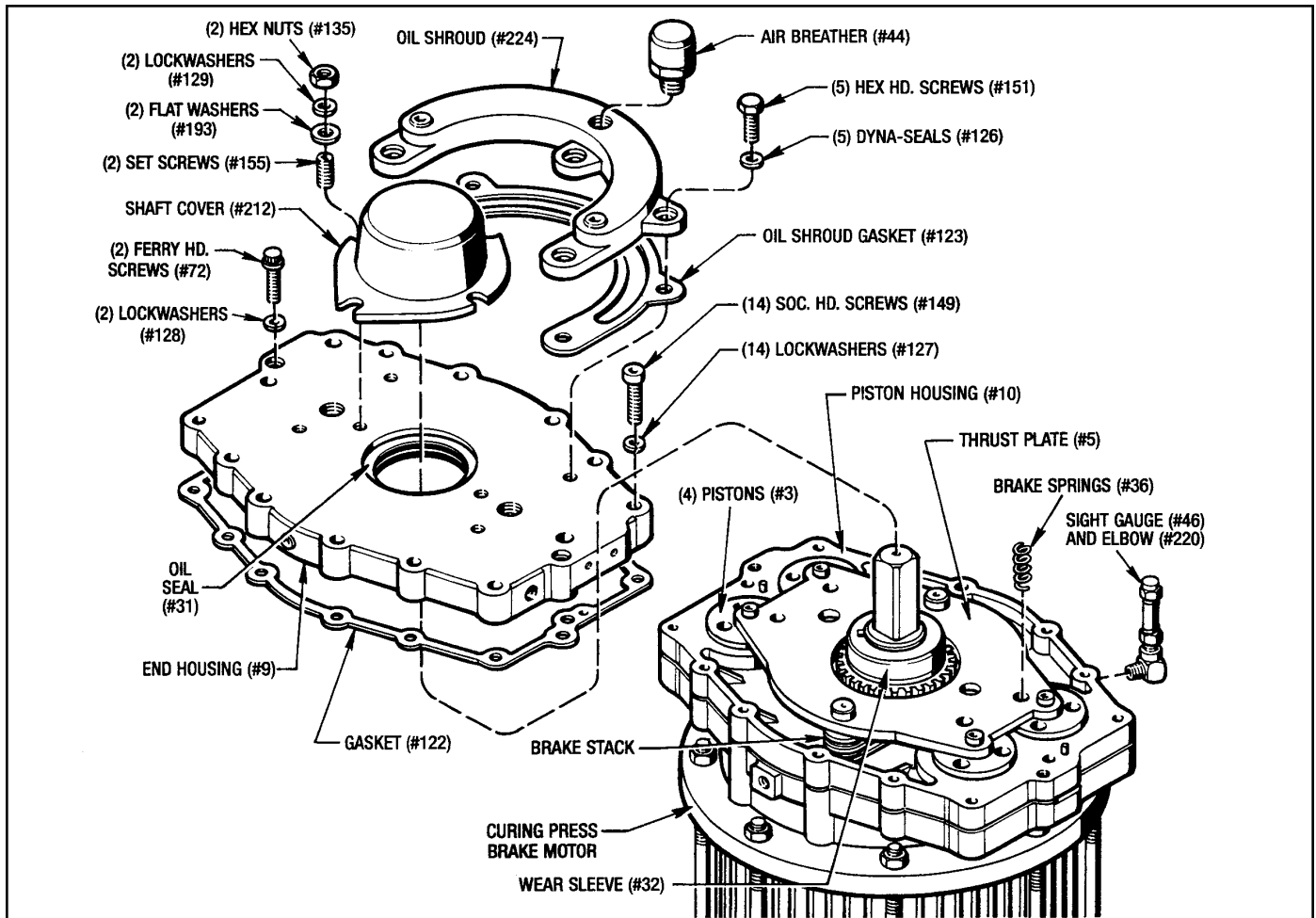

Figure 9.7 - Final Reassembly

9-8 INSTALLING BRAKE SPRINGS (#36) AND END HOUSING (#9)

(See Figure 10.1)

1. Place the proper amount of Springs (#36) into each Piston (#3) for your Torque Requirements. (See Figure 9.6 .)
2. Place a new Gasket (#122) on the Piston Housing (#10). Use the (2) Pins (#158) for alignment. **Do not use any Gasket Sealant on this gasket.**
3. Attach the End Housing (#9) to the Piston Housing (#10) with the following procedure.

NOTE - Lubricate the lip of the Oil Seal (#31) in the End Housing (#9) and the Wear Sleeve (#32) on the Hub (#2) with oil or vaseline before Reassembly. **Be very careful when attaching this End Housing (#9) so you don't damage the oil seal lip.**

4. The Springs (#36) have to be compressed evenly so first install the (2) Ferris Hd. Screws (#72) and (2) Lockwashers (#128). **Only tighten down enough so the (14) Screws (#149) can be engaged.**

5. Install the (14) Screws (#149) and (14) Lockwashers (#127). **Tighten these (14) Screws (#149) down in an even manner to properly compress the Springs (#36).**

6. **Torque all (16) Screws to 25 Ft. Lbs.**

Before going any further make an Operational Check to see if the pistons are operating properly. (**See Section 5 - Operational Checks on page 7.**)

Step 1 - Before applying air pressure try to turn the drive motor shaft with a barring bar. The drive motor shaft should not be able to be turned.

Step 2 - Apply the proper air pressure and try to turn the drive motor shaft with the barring bar. The drive motor shaft should be able to be turned.

7. Attach the Shaft Cover (#212) with (2) Set Screws (#155), (2) Lockwashers (#129) and (2) Flat Washers (#193).

NOTES:

1. Use **Red Loctite #271** on the bottom part of the (2) Set Screws (#155) to act as a sealant in the housing.

2. Make sure you leave enough exposed thread above the cover flange so the Flat Washer (#193), Lockwasher (#129) and the Nut (#135) fits. **Torque the Hex Nut to 14 Ft. Lbs.**
8. On Vertical Brakes, place the Oil Shroud Gasket (#123) and Oil Shroud (#224) in place on the End Housing (#9). Attach with (2) Hex Hd. Screws (#151) and (2) Dyna-Seals (#126). **Torque to 14 Ft. Lbs.**

NOTE - Do not use any gasket sealant on this gasket.

9. Re-install the Sight Gauge (#46), Air Breather (#44) and any other fittings or pipe plugs removed at dis-assembly.
10. Fill the brake with fresh oil as indicated in **Section 4 - Lubrication.**
11. Re-connect the control valve and any pneumatic piping that was removed.

Reassembly is now complete and your Posistop Curing Press Motor Brake is ready for service.

Section 10 ILLUSTRATED PARTS LIST

10-1 GENERAL INFORMATION

This section illustrates, lists and describes all parts for the **Curing Press Motor Brake**. Parts are identified on the exploded views with Part Reference Numbers. These Numbers correspond to the Part Reference Number given in the Parts Lists. The Part Name and Quantity Used is also given in the Parts List. This Part Reference Number, Part Name and Quantity should be used when ordering Replacement Parts.

10-2 FACTORY REBUILD SERVICE

Reconditioning Service is offered by Force Control Industries, Inc. at the factory. A complete factory rebuild will be 50% the cost of a new unit if the housings are reusable. If housings need to be replaced, there will be an additional cost.

Contact **Force Control Industries, Inc.** for authorization and shipping instruction before returning a drive unit for this service. Force Control cannot be responsible for units returned to the factory without prior notice and authorization.

Care must be given to the packing of returned brakes. Always protect mounting surfaces by attaching to a skid. Shipment-damaged brakes always delays repairs. It is usually impossible to recover damage costs from the carrier. When possible, describe the problem experienced on your shipping papers.

Return to: **Force Control Industries, Inc.**
3660 Dixie Highway
Fairfield, Ohio 45014
Phone: (513) 868-0900
Fax: (513) 868-2105
E-Mail: info@forcecontrol.com

10-3 ORDERING REPLACEMENT PARTS

When ordering replacement parts, please specify all of the following information:

1. Brake Model Number (*On the Name Plate.*)
(*See next page.*)
2. Brake Serial Number (*On the Name Plate.*)
3. Part Reference Number (*From the parts list or exploded view drawing.*)
4. Part Name (*From the parts list.*)
5. Quantity (*From the parts list.*)
6. Complete Shipping Information.

Failure to include information for items 1 through 6 will only delay your parts order. Unless another method is specified for item 6, parts weighing less than 150 Lbs. will be shipped United Parcel Service. Parts weighing more than 150 Lbs. will be shipped Motor Freight. Air freight and other transportation services are available but only if specified on your order.

10-4 NAME PLATE INFORMATION

The Name Plate will be located on the End Housing (#9). (*See next page.*)

10-5 MODEL NUMBER INFORMATION



Force Control Industries, Inc. Fairfield, Ohio
 For Service / Parts Call: **513-868-0900**

Posistop® Brake Model No.
 Serial No.

Use Mobil ATF 210

Example:

CPB-10-120-9-5-U-V7-1

Size 10 Curing Press Brake with 120 Ft. Lbs. Torque, 9' B.C., 1-5/8" Dia. Bore, Vertical Mounting, Control Valve-Preplumbed & Mounted.

Model Number...

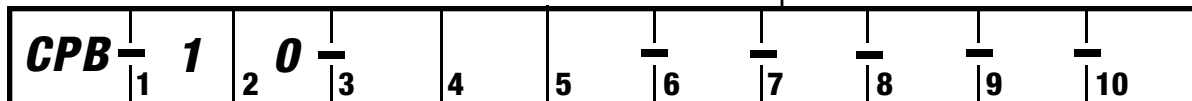

Curing Press Brake

Brake Size (1, 2)

1 0 = Size 10 Brake

Torque (3, 4, 5)

Size 10 Brake

1 4 5 = 145 Ft. Lbs.

1 2 0 = 120 Ft. Lbs.

0 9 5 = 95 Ft. Lbs.

0 7 5 = 75 Ft. Lbs.

0 4 8 = 48 Ft. Lbs.

Bolt Circle (6)

7 = 7-1/4" Dia.

9 = 9" Dia

Control Valve (9)

V 1 = Ship Valve Loose

V 7 = Preplumb & Mount

N = None

Mounting (8)

H = Horizontal

U = Vertical (*Brake Up*)

Bore Diameter (7)

1 = 1-1/8" Dia.

3 = 1-3/8" Dia.

5 = 1-5/8" Dia.

S = Special

Revision (10)

By Force Control

Repair Parts List *Curing Press Motor Brake*

REF. No.	PART NAME	QTY.	REF. No.	PART NAME	QTY.
2	Hub.....	1	*121	Gasket 7" Housing	1
3	Piston	4	*122	Gasket Piston Housing.....	1
5	Brake Pressure Plate.....	1	*123	Oil Shroud Gasket (<i>Vertical Only</i>)	1
7	Input Housing.....	1	*126	Dyna-Seal, 5/16"	5
9	End Housing.....	1	127	Lockwasher, 3/8"	14
10	Piston Housing.....	1	128	Lockwasher, 3/8"	4
*12	Drive Plate	3	129	Lockwasher, 5/16"	2
•13	Friction Disc	2	132	90° Street Elbow, 1/4" NPT	1
*17	Separator Springs	4	135	Hex Nut, 5/16"-18.....	2
*31	Oil Seal.....	2	149	Soc. Hd. Cap Screw, 3/8"-16 x 2-1/2" Lg.	14
*32	Wear Sleeve.....	2	151	Soc. Hd. Cap Screw, 5/16"-18 x 1.5" Lg. (<i>Vertical Only</i>)	5
*36	Compression Spring				
	48 Ft. Lbs.....	4	152	Soc. Hd. Cap Screw, 1/2"-13 x 1-3/4" Lg.	4
	75 Ft. Lbs.....	6	153	Soc. Hd. Cap Screw, 3/8"-16 x 1" Lg.	2
	95 Ft. Lbs.....	8	155	Soc. Set Screw, 5/16"-18 x 1-1/4" Lg.	2
	120 Ft. Lbs.....	10	158	Dowel Pin, 1/4" x 7/8" Lg.....	4
	145 Ft. Lbs.....	12	167	Lockwasher, 1/2" (<i>9" Dia. B.C. Only</i>)	2
*39	O-Ring	8	176	Dowel Pin, 5/8" x 2" Lg.	2
*42	Liner, I.D. Sealing.....	4	180	Hub Key	
44	Air Breather	1		1/4" Sq. x 2-1/2" (<i>1-1/8" - 1-1/4" Dia. Hub</i>)	1
46	Sight Gauge, Stand-Off	1		5/16" Sq. x 2-1/2" (<i>1-3/8" Dia. Hub</i>)	1
64	Pipe Plug, 1/4" NPT Mag. Sq. Hd.....	1		3/8" Sq. x 2-1/2" (<i>1-5/8" Dia. Hub</i>)	1
72	Ferry Hd. Cap Screw, 3/8"-16 x 2" Lg.....	2	*183	Hub Positioning Shims.....	AR
73	C'Sunk Pipe Plug, 3/8" NPT.....	2	193	Flat Washer, 1/4"	2
75	C'Sunk Pipe Plug, 1/4" NPT.....	3	212	Shaft Cover	1
*81	Brass Washer, 7/16"		220	Brass Elbow, 1/4" NPT.....	1
	7-1/4" Dia. B.C.....	4	224	Oil Shroud (<i>Vertical Only</i>)	1
	9" Dia. B.C.	2	267	C'Sunk Pipe Plug, 1/4" NPT.....	1
108	Soc. Set Screw, 3/8"-16 x 3/8" Lg.....	2	268	Sq. Hd. Pipe Plug, 1/4" NPT	1
119	Roll Pin, 3/16" x 3/4" Lg.	4	272	Shoulder Bolt, 3/8" x 3/8".	4

AR - As Required

* - Indicates Parts in Overhaul Kit.

CURING PRESS MOTOR BRAKE

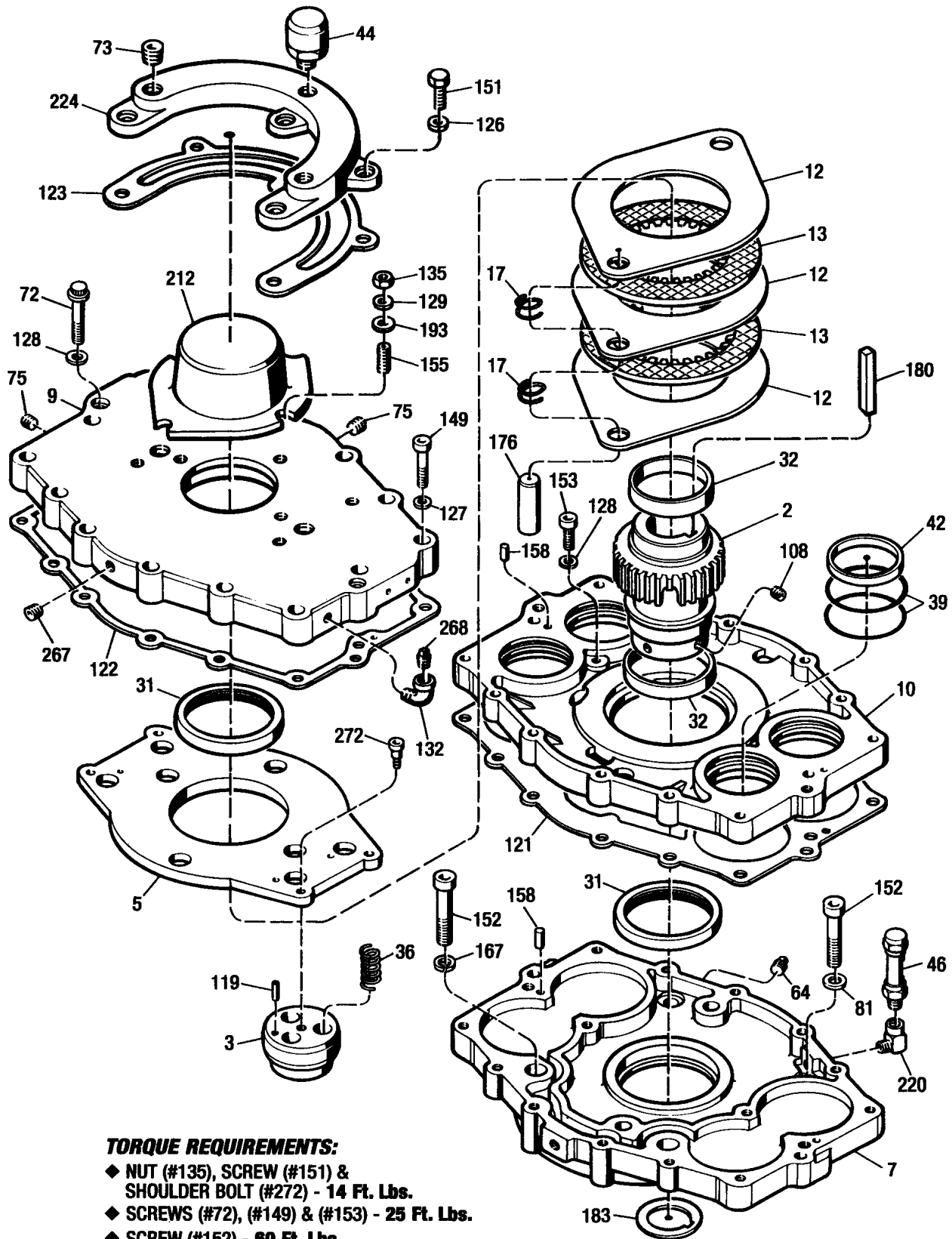

Figure 10.1 - Curing Press Brake Repair Parts

FORCE CONTROL INDUSTRIES, INC.



MEX (55) 53 63 23 31 MTY (81) 83 54 10 18
 QRO (442) 1 95 72 60 ventas@industrialmagza.com

FORCE CONTROL INDUSTRIES, Inc.

*Providing today's industries
with Oil Shear Clutch and
Brake Drives that delivers:
Flexibility • Efficiency
Endurance • Performance
Dependability*

"Built to Last - Guaranteed to Perform"



FORCE CONTROL INDUSTRIES, Inc.

MAIN OFFICE

P.O. Box 18366
Fairfield, Ohio 45018

3660 Dixie Highway
Fairfield, Ohio 45014

Tel: (513) 868-0900

Fax: (513) 868-2105

E-Mail: info@forcecontrol.com

DETROIT OFFICE

24419 Sorrentino Court
Clinton Twp., Mich. 48035

Tel: (810) 792-5710

Fax: (810) 792-7329

E-Mail: info@forcecontrol.com