

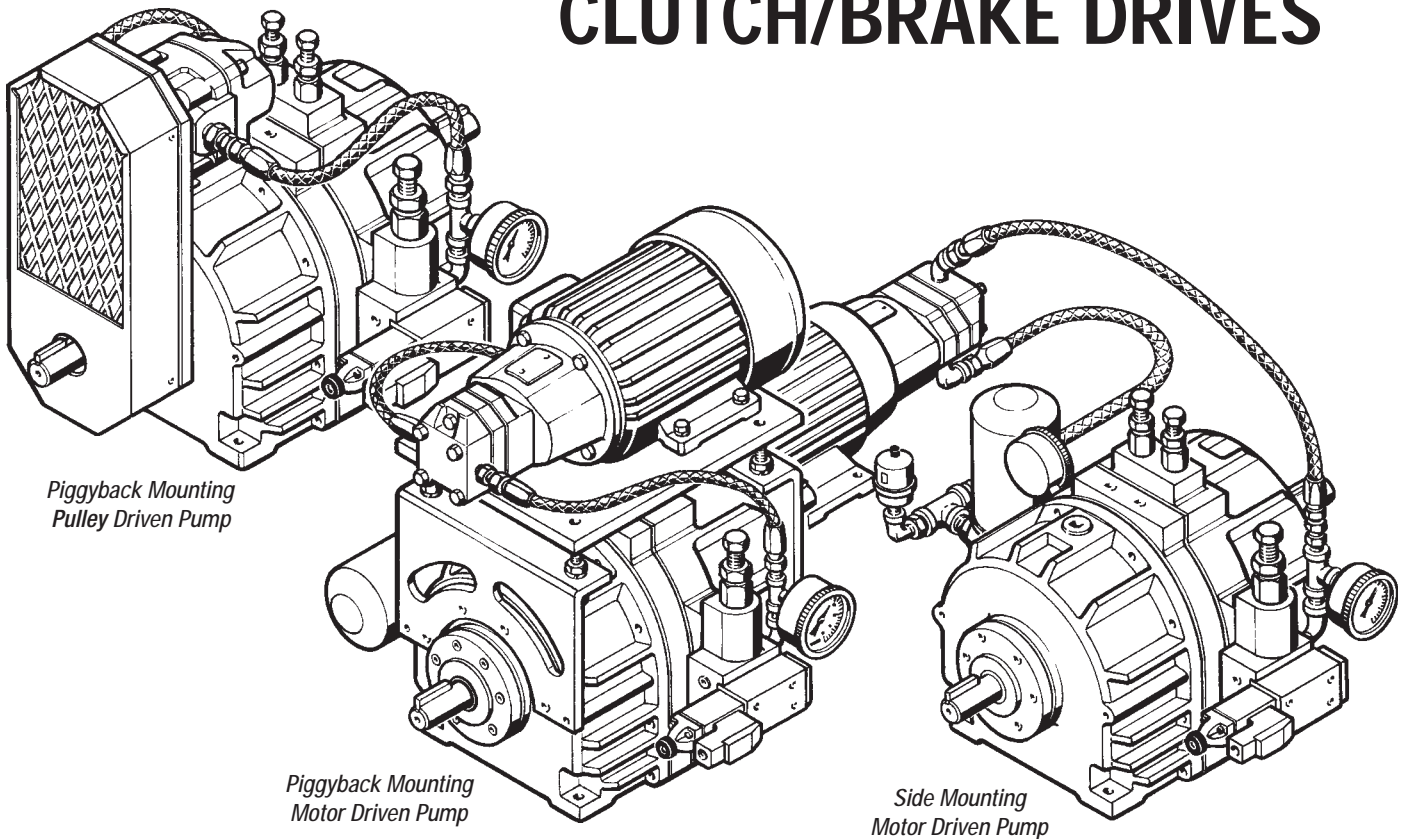

502-EH-2.5-001-01

SERVICE MANUAL AND REPAIR PARTS FOR Size EH-2.5 *Posidyne*[®] Electro/Hydraulic CLUTCH/BRAKE DRIVES



*Piggyback Mounting
Pulley Driven Pump*

*Piggyback Mounting
Motor Driven Pump*

*Side Mounting
Motor Driven Pump*



FORCE CONTROL INDUSTRIES, INC.

WARNING - Read this manual before any installation, maintenance and operation.

MANUFACTURERS OF MECHANICAL AND ELECTRICAL POWER TRANSMISSION EQUIPMENT



MEX (55) 53 63 23 31 MTY (81) 83 54 10 18
QRO (442) 1 95 72 60 ventas@industrialmagza.com

Limited Warranty

Upon written approval of the application by Force Control Industries, Inc. the standard warranty period will be extended to 24 months from date of shipment.

Force Control Industries, Inc. ("Force Control") warrants its products to be free from defects in material and workmanship under normal and proper use for a period of one year from the date of shipment. Any products purchased from Force Control that upon inspection at Force Control's factory prove to be defective as a result of normal use during the one year period will be repaired or replaced (at Force Controls' option) without any charge for parts or labor. This limited warranty shall be void in regard to (1) any product or part thereof which has been altered or repaired by a buyer without Force Control's previous written consent or (2) any product or part thereof that has been subjected to unusual electrical, physical or mechanical stress, or upon which the original identification marks have been removed or altered. Transportation charges for shipping any product or part thereof that the buyer claims is covered by this limited warranty shall be paid by the buyer. If Force Control determines that any product or part thereof should be repaired or replaced under the terms of this limited warranty it will pay for shipping the repaired or replaced product or part thereof back to the buyer. EXCEPT FOR THE EXPRESS WARRANTY SET OUT ABOVE, FORCE CONTROL DOES NOT GRANT ANY WARRANTIES EITHER EXPRESSED OR IMPLIED, INCLUDING IMPLIED WARRANTIES OF MERCHANTABILITY OR FITNESS FOR USE. The warranty obligation set forth above is in lieu of all obligations or liabilities of Force Control for any damages. Force Control specifically shall not be liable for any costs incurred by the buyer in disconnecting or re-installing any product or part thereof repaired or replace under the limited warranty set out above. FORCE CONTROL EXPRESSLY EXCLUDES ALL LIABILITY FOR ANY INDIRECT OR CONSEQUENTIAL DAMAGES THE BUYER MAY SUSTAIN IN CONNECTION WITH THE DELIVERY, USE, OR PERFORMANCE OF FORCE CONTROL PRODUCTS. Under no circumstances shall any liability for which Force Control is held responsible exceed the selling price to the buyer of the Force Control products that are proven to be defective. This limited warranty may be modified only in writing signed by a duly authorized officer of the company. This limited warranty applies exclusively to Force Control products; warranties for motors and gear reducers and other component parts may be provided by their respective manufactures. Any legal action for breach of any Force Control warranty must be commenced within one year of the date on which the breach is or should have been discovered.

A Return Goods Authorization (RGA) number must be obtained from the factory and clearly marked on the outside of the package before any equipment will be accepted for warranty work. Force Control will pay the shipping costs of returning the owner parts that are covered by warranty.

Force Control believes that the information in this document is accurate. The document has been carefully reviewed for technical accuracy. In the event that technical or typographical errors exist, Force Control reserves the right to make changes to subsequent editions of this document without prior notice to holders of this edition. The reader should consult Force Control if errors are suspected. In no event shall Force Control be liable for any damages arising out of or related to this document or the information contained in it.



Table of Contents

Section 1-DESCRIPTION and OPERATION

1-1 The Oil Shear Principle	1
1-2 Description	1
1-3 Operation	1
1-4 Available Mounting Configurations	2
1-5 Other Available Options	2

Section 2-SPECIFICATIONS

2-1 Model Designations	3
2-2 Specifications	3

Section 3-INSTALLATION

3-1 Receiving the Drive	4
3-2 Mounting the Drive	4

Section 4-LUBRICATION

4-1 Checking the Oil Level	5
4-2 Oil Capacity	5
4-3 Changing the Oil	5
4-4 Type of Oil	5

Section 5-OPERATIONAL CHECKS

5-1 Checking Piston Actuation	6
5-2 Checking Clutch/Brake Engagement	6
5-3 Drive Motors	6

Section 6-TROUBLESHOOTING

6-1 Trouble Shooting Chart	7
6-2 Checking Clutch/Brake Stacks for Wear	9
6-3 Motor Driven Hydraulic Pump Units	9
A. Brake Stack Wear	9
B. Clutch Stack Wear	9

Section 7-DISASSEMBLY

7-1 General Disassembly Procedure	10
7-2 Removing Hydraulic Control Valves	10
7-3 Removing C-Face Mntd. Motor and C-Face Flanges	11
7-4 Removing Fan Shroud and Fan	11
7-5 Removing Positioning Encoder Assembly	11
7-6 Removal of Quadrature Sensor & Magnetic Pick-Up	11
7-7 Access to Clutch and Brake Stacks	11
7-8 Removing Piston Housing Assembly	12
7-9 Removing Piston Seals	12
7-10 Piston Disassembly	12
7-11 Output Housing Disassembly	13
7-12 Disassembly of Input Housing Sub-Assembly	13
A. Removing Water Cooled Heat Exchanger	13
B. Removing Male Input Shaft	13
C. Removing Quill Input Shaft	14

Section 8-CLEANING and INSPECTION

8-1 Cleaning and Inspection	15
8-2 Repair and Replacement	15

Section 9-REASSEMBLY

9-1 General Reassembly Instructions	15
9-2 Reassembly of Input Housing Sub-Assembly	15
A. Installing Male Input Shaft	15
B. Installing Quill Input Shaft	16
9-3 Installing Water Cooled Heat Exchanger	16
9-4 Output Housing Installation	17
9-5 Reassembly of Piston Sub-Assembly	18
9-6 Installing Piston Sub-Assembly and Piston Springs ..	18
9-7 Installing Piston Retainer	19
9-8 Installing Clutch Stack	19
9-9 Installing Input Housing Sub-Assembly	19
9-10 Installing Hydraulic Control Valves	19
9-11 Installing Positioning Encoder Assembly	19
9-12 Installing Quadrature Encoder and Magnetic Pick-up	20
A. Quadrature Encoder	20
B. Magnetic Pick-up Sensor	20
9-13 Installing Fan and Fan Shroud	21
9-14 Attaching C-Face Adapters	21
A. Output C-Face Adapter	21
B. Input C-Face Adapters	21
9-15 Final Reassembly	21

Section 10-ILLUSTRATED PARTS LIST

10-1 General Information	22
10-2 Drive Motors	22
10-3 Factory Rebuild Service	22
10-4 Ordering Replacement Parts	22
10-5 Name Plate	22

REPAIR PARTS

Figure 10.1 - EH-2.5 <i>Posidyne</i> Clutch/Brake Assembly	25
Figure 10.2 - Output C-Face Adapter(8-1/2" AK Dia.)	26
Figure 10.3 - Input Housing Sub-Assembly	27
Figure 10.4 - Fan Cooling	29
Figure 10.4 - Water Cooling	29
Figure 10.5 - Positioning Encoder Assembly	31
Figure 10.5 - Hydraulic Control Valves	31
Figure 10.6 - Piggyback Mounting/Motor Driven Pump	33
Figure 10.7 - Piggyback Mounting/Pulley Driven Pump	35
Figure 10.8 - Side Mounting/Motor Driven Pump	37

Section 1

DESCRIPTION and OPERATION

1-1 THE OIL SHEAR PRINCIPLE

Conventional clutches and brakes depend on the friction between solid surfaces operating in air to transmit torque. Friction does the job, but produces a great amount of heat and wear. The *EH-2.5 Posidyne* Clutch/Brake unit is an oil shear drive, with the friction surfaces operating in a bath of oil. The oil molecules tend to cling to each other, and to the friction surfaces. As moving and stationary elements are brought together, a thin but positive film of oil is maintained between them. The oil film is controlled by a clamping pressure and by carefully designed grooves in the elements. Torque is transmitted from one element to the other through the viscous shear of the oil film. So long as there is relative motion between the elements, they are protected by the oil, thus greatly reducing wear. The oil bath also effectively transmits heat away from the friction elements.

1-2 DESCRIPTION

(See Figure 1.1)

In the *EH-2.5 Posidyne* Clutch/Brake, the friction surfaces

consist of alternate carbon steel plates and advanced friction material on steel discs. The oil control grooves are molded into the friction material disc surfaces. The discs have internal teeth which mate with a spline on the output shaft for both clutch and brake applications. The steel plates are keyed to the input shaft in the clutch and to the housing for the brake when used. The splined sections of the *Posidyne* output shaft contain centrifugal impellers to maintain a positive flow of oil between the discs and plates.

As noted in Section 2, Specifications, standard *Posidyne* units may be equipped with a clutch and a brake, or a clutch only. The Clutch is operated by hydraulic pressure. The *Posidyne* brake may be pressure operated, or it may be spring loaded to operate automatically when the clutch is released, or a combination of both springs and pressure.

1-3 OPERATION

The *EH-2.5 Posidyne* cross-section (Figure 1.1) shows the drive with the Brake engaged. A nominal braking force

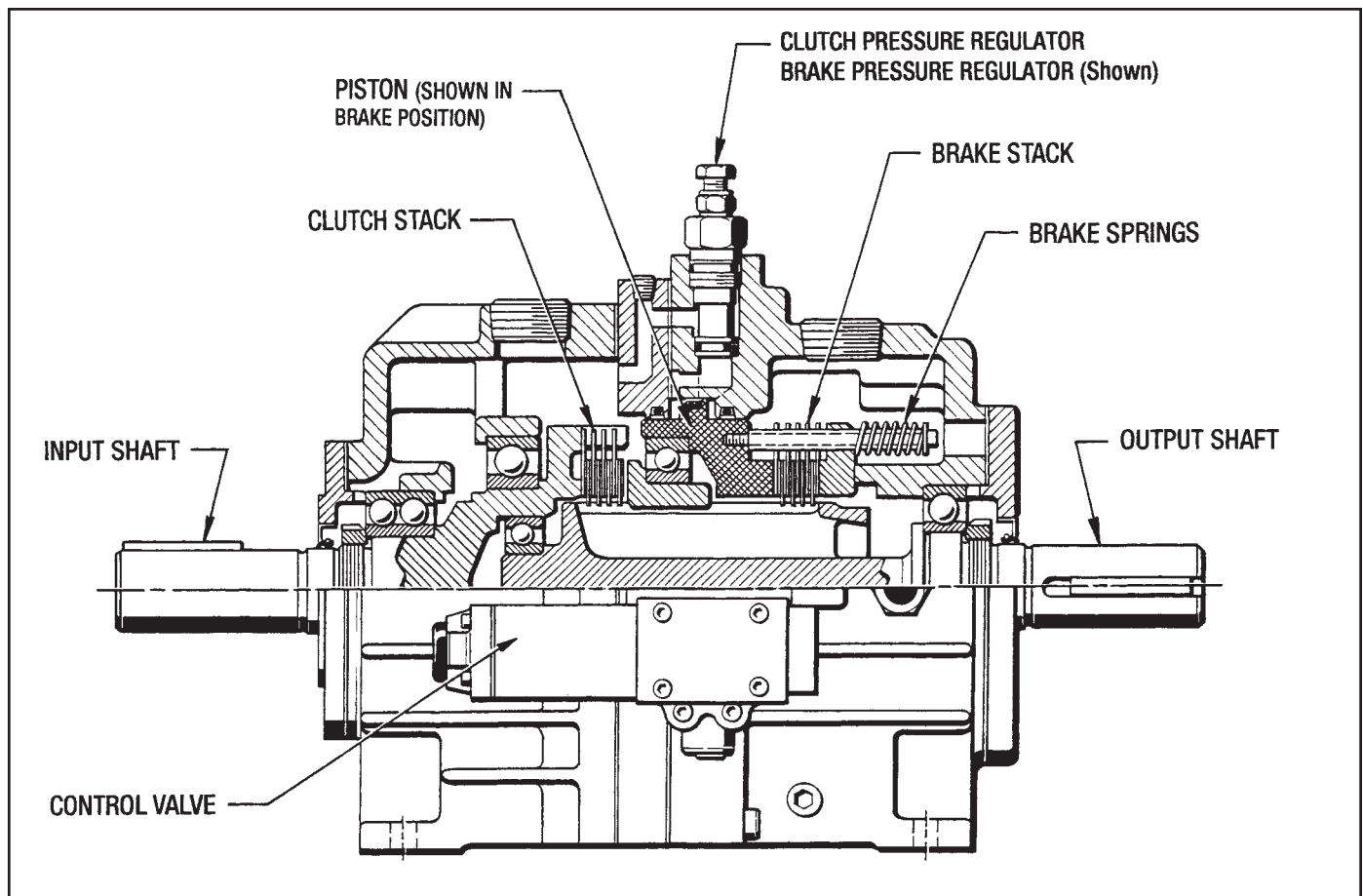

Figure 1.1 - *EH-2.5 Posidyne* Clutch/Brake Unit

is provided by springs located in the Output Housing.. Heavier springs are used to provide a greater braking force, when needed. Pressure Assist (as shown), controlled by external valves, also provides a greater braking force. The drive is normally in the Brake Position. The Drive Plates are keyed to the Output Housing and the Friction Discs are splined to the Output Shaft. The Output Shaft is not able to rotate in the Brake Position.

The Clutch is engaged when the hydraulic pressure is exhausted from the Brake Port and applied to the Clutch Port. The Piston moves to compress the Clutch Stack on the Input Shaft. The Drive Plates are keyed to the Input Shaft and the Friction Discs are splined to the Output Shaft. This allows both shafts to rotate at the same speed.

1-4 AVAILABLE MOUNTING CONFIGURATIONS

There are (3) basic mounting configurations for the EH-2.5 *Posidyne* Clutch/Brake Units.

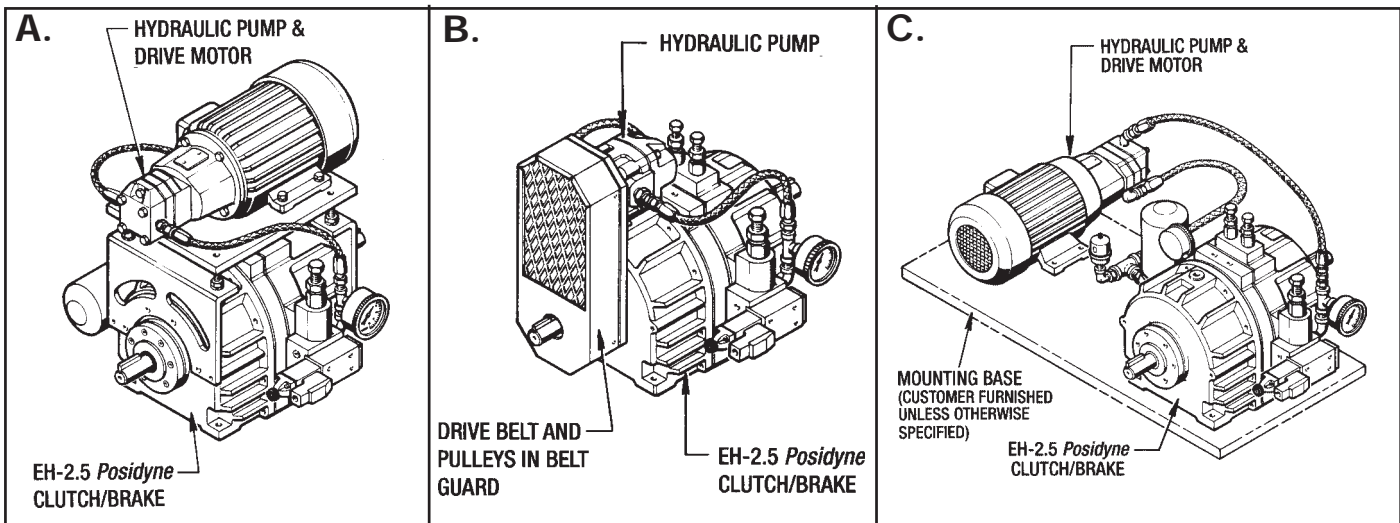

Figure 1.2 - Mounting Configurations

A. Piggyback Mounting/Motor Driven Pump

(See Figures 1.2A and 10.6)

The Hydraulic Pump and Drive Motor is piggyback mounted above the *Posidyne* Unit for an efficient and compact design.

B. Piggyback Mounting/Belt Driven Pump

(See Figures 1.2B and 10.7)

(Non-Reversing Applications Only)

This Piggyback Mounted Unit uses a Timing Belt and Pulleys to drive the Hydraulic Pump, which is driven off the Input Shaft.

C. Side Mounting/Motor Driven Pump

(See Figures 1.2C and 10.8)

The Hydraulic Pump and Drive Motor is mounted on the side of the *Posidyne* Unit usually on a common base which is customer furnished unless otherwise specified.

1-5 OTHER AVAILABLE OPTIONS

- Quill Input Shaft, C-Face Mounting.** (Not available with Mounting Configuration B.)
 - 4-1/2" AK, 7/8" U
 - 8-1/2" AK, 1-1/8" U
 - 8-1/2" AK, 1-3/8" U
- Output C-Face Mounting.**
 - 4-1/2" AK, 7/8" U
 - 8-1/2" AK, 1-1/8" U
 - 8-1/2" AK, 1-3/8" U
- Fan Cooling.** (Not available with Quill Input Shaft or Mounting Configuration B)
- Water Cooling.**
- Positioning Encoder Assembly.** (Not available with C-Face Mounting on the Output Shaft.)

Contact Force Control Factory for further information on Available Options and Mounting Configurations.

Section 2 SPECIFICATIONS

(EH-2.5 Posidyne CLUTCH/BRAKE)

NOTE:

Type A and B units both have spring actuated brakes. The difference is that type B units have additional springs.

2-1 MODEL DESIGNATIONS

The model designations specifies the size (EH-2.5.) and internal logic type. The types are:

- S** - Pressure set clutch, light spring set brake with pressure assist.
- SA** - Pressure set clutch, medium spring set brake with pressure assist.
- A** - Pressure set clutch, medium spring set brake (See NOTE following).
- B** - Pressure set clutch, heavy spring set brake (See NOTE following).
- C** - Pressure set clutch, no brake.
- P** - Pressure set clutch and brake, No springs.

2-2 SPECIFICATIONS

Specifications for the EH-2.5 Posidyne Clutch/Brake Drives are listed in Table 2.1

TORQUE RATINGS

The torque ratings listed are based on maximum actuation pressure as specified in the Table 2.1.

Table 2.1 SPECIFICATIONS

Size	Logic	Clutch Torque (Lb. In.)		Brake Torque (Lb. In.)				Max. (RPM)		Max. KE per Engmt. (Ft. Lbs.)	Average Thermal HP			Inertia of Cyclic Parts (Lb. Ft. ²)
		Static @ PSIG	Dynamic @ PSIG	Springs Only		w/ Max. Pr. Assist		Basic & Fan Cool	Water Cool		Cooling*			
				Static	Dyn	Static	Dyn				Basic	Fan	Water **	
													Basic	Fan
2.5	S	1116 @ 100	964 @ 100	122	105	1183 @ 70	1022 @ 70	1800	3600	7500	.70	2.00	4.00	.20
	SA	1245 @ 150	1075 @ 150	424	366	1378 @ 63	1190 @ 63							
	A	1237 @ 150	1068 @ 150	424	366	---	---							
	B	794 @ 161	686 @ 161	860	743	---	---							
	C	1063 @ 119	918 @ 119	---	---	---	---							
	P	1160 @ 95	964 @ 95	0	0	1183 @ 88	1022 @ 88							

NOTES:

* Ratings based on 1800 RPM operating speed and 70° ambient temperature.

** Cooling water flow requirements in GPM equals .10 x calculated thermal horsepower.

Section 3

INSTALLATION

3-1 RECEIVING THE DRIVE

Check the drive for shortage or damage immediately after arrival. Prompt reporting to the carrier's agent, with notations made on the freight bill, will expedite satisfactory adjustment by the carrier. When unloading or handling the drive, keep it upright. All Drives are filled with oil, ready to run, when shipped. However, before placing the unit in service or storage, check the oil level to make sure none has spilled out in transit. Add oil if necessary (refer to **Section 4 - Lubrication**). Remove the red plastic plug and install the Air Breather (#45). If the drive is not to be installed and operated soon after arrival, store it in a clean, dry place having slow, moderate change in ambient temperature.

3-2 MOUNTING THE DRIVE

Installation of the Drive should be made in much the same manner, and receive the same care for a precision gear reducer. Note the following precautions when mounting the drive:

1. The Drive should be mounted on a firm, level base or foundation, common with both the driving and driven components.
2. Use SAE Grade 5 Hex. Hd. Cap Screws to bolt the drive securely into place. Before tightening down the bolts, check alignment with both the driving and driven machinery, then recheck after tightening.
3. If the input or output shaft is to be directly coupled, use only a flexible coupling (with horsepower service factor 3 to 1) to take care of maximum torque requirements. Make sure that the shafts to be coupled are concentric within 0.005 in. TIR. Check for horizontal, vertical and angular misalignment. Use shims as necessary to correct.

CAUTION:

Do not drive couplings or bushings on shaft.

4. If the Drive is to be connected through a belt, chain or gear drive, locate as close as possible to the housing to minimize overhung loads. Make sure that the sheaves, sprockets or gears are in line and that the shafts are parallel.
5. After the machinery has been in operation for a few hours, make sure that all mounting bolts are tight and recheck the alignment of all components.
6. After machinery has been in operation for 40 hours check the mounting bolts and tighten if necessary.

Section 4 LUBRICATION

4-1 CHECKING THE OIL LEVEL

When the drive is installed and weekly thereafter, or until experience dictates otherwise, check the oil level. Always check the oil level with the drive at room temperature and while it is not running.

The drive has an oil sight gauge located at the output end of the drive. The oil level is to be at the center of the gauge.

4-2 OIL CAPACITY

The **Oil Capacity** for the EH-2.5 *Posidyne* is **3 quarts**.

4-3 CHANGING THE OIL

IMPORTANT

Open the disconnects to the drive motors before attempting to change the oil.

After the first 30 days of operation completely drain the oil from the drive using the drain plugs provided. Remove and replace the cartridge oil filter with a new filter. If the oil sight glass is dirty it should be removed and cleaned.

Reinstall the drain plugs and refill the drive to the center of the sight glass with fresh oil.

After the first oil change check the oil level and color of the oil at least once per month. Maintain the oil level to the center of the sight glass by adding additional oil as needed. The oil and filter should be changed after every 12 months of operation there after.

CAUTION

Do not overfill the Drive Unit. Excess oil will cause the unit to overheat.

4-4 TYPE OF OIL

Use only **Mobil Automatic Transmission Fluid ATF-210 (type "F")** or **Mobil Multi-purpose Automatic Transmission Fluid** for most drives. Other fluids may be specified for special applications. **Always use the type of fluid specified on the Name Plate.**

Section 5 OPERATIONAL CHECKS

Make these Operational Checks with the driver shut down and locked out. Also remove the (2) Inspection Plugs from the drive unit. **Do not remove these inspection plugs while the drive unit is running.**

If automatic controls are used, make provisions for manual operation. If the drive unit has been removed for repair, make temporary, manually controlled hydraulic connections. (See Figure 5.1 for Hydraulic Schematic.)

The Manifold (#105), Control Valve (#387), Pressure Relief Valves (#388 and #400) and the Pressure Gauges (#327 and #397) all have to be in place and attached to the unit. (See Figure 10.5)

5-1 CHECKING PISTON ACTUATION

(Motor Driven Hydraulic Pump Units Only)

1. With the hydraulic pump running, press and hold the "Manual Override" button to apply pressure to the clutch port. At the same time, observe the piston movement to see if it actuates quickly and smoothly. If the piston movement is irregular and has a tendency to stick or bind, internal damage may be indicated. If the piston moves slowly, the piston seals are probably leaking.

Release the "Manual Override" button and observe the piston to see if it returns back to its original position quickly and smoothly.

5-2 CHECKING CLUTCH/BRAKE ENGAGEMENT or INPUT SHAFT Vs. OUTPUT SHAFT ROTATION

(With Male Input Shaft)

1. When applying pressure to the clutch port, simply rotate the input shaft by hand and observe the rotation of the output shaft.

When the pressure is not applied to the clutch or when applied to the "Pressure Assist" brake port, the output shaft should be locked and not able to rotate.

With SCP Logic, the output shaft is free to rotate when pressure is not applied to the brake. Applying pressure to the brake should lock the output shaft.

(With C-Face Mounted Drive Motor)

If the C-Face mounted drive motor is still attached, the input shaft is not accessible to be manually rotated.

1. Temporarily hook-up drive motor and "Bump" it to check the clutch or brake operating modes and output shaft rotation.

CAUTION: Do not attempt to run the drive motor with the inspection plugs removed. They must first be replaced.

5-3 DRIVE MOTORS

Check wiring connections against the wiring diagram on the motor name plate. "Bump" the motor and check direction of rotation. Check all connections for tightness.

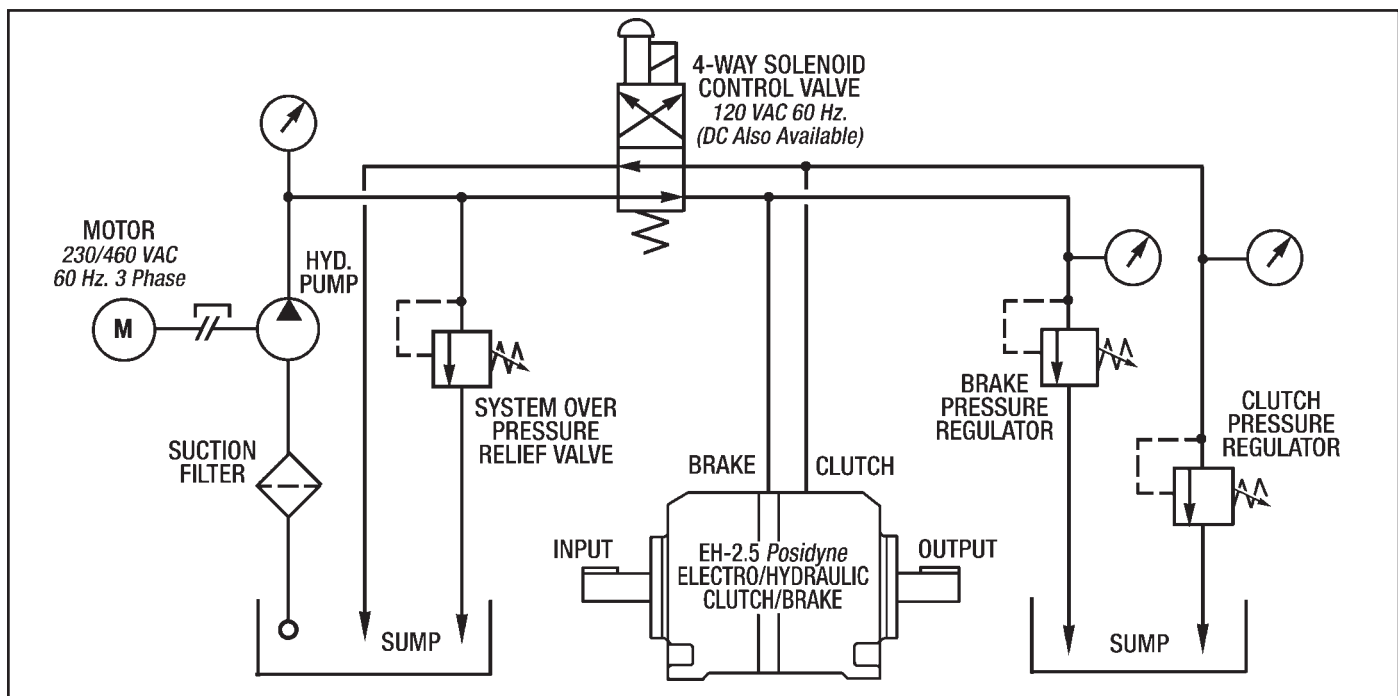

Figure 5.1 - Hydraulic Schematic

Section 6 TROUBLESHOOTING

6-1 TROUBLESHOOTING CHART

TROUBLE	POSSIBLE CAUSE	REMEDY
Both clutch and brake fail to engage properly.	<p>Electrical control circuit.</p> <p>Low hyd. pressure.</p> <p>Hyd. pressure regulator or piping.</p> <p>Worn friction surfaces.</p> <p>Improper type of oil</p>	<p>Check control circuit.</p> <p>Increase hyd. pressure.**</p> <p>Check for improper operation or leaks.</p> <p>Check parts for wear and replace if necessary. (See Section 6-2)</p> <p>Check name plate and change oil if necessary.</p>
Clutch fails to engage properly.	<p>Electrical control circuit.</p> <p>Valve not functioning properly.</p> <p>Internal hyd. leakage.</p> <p>Low hyd. pressure</p> <p>Worn friction surfaces.</p>	<p>Check control circuit.</p> <p>Check valve operation. Replace if necessary.</p> <p>Check and replace O-Rings and Liners if necessary.</p> <p>Increase hyd. pressure.**</p> <p>Check parts for wear and replace if necessary. (See Section 6-2)</p>
Picks up load too quickly.	<p>Hyd. pressure too high.</p> <p>Low oil level.</p>	<p>Reduce hyd. pressure.</p> <p>Check oil level and add if necessary.</p>
Clutch fails to disengage properly.	<p>Electrical control circuit.</p> <p>Valve not functioning properly.</p> <p>Piston sticking-broken return springs.</p>	<p>Check control circuit.</p> <p>Check and replace valve if necessary.</p> <p>Disassemble to extent necessary and inspect for damaged parts.</p>
Noise and vibration	<p>Mounted on poor foundation.</p> <p>Misaligned couplings.</p> <p>Damaged bearings.</p>	<p>Improve installation. Tighten foot bolts.</p> <p>Recheck alignment.</p> <p>Disassemble to extent necessary and inspect for damaged bearings.</p>
Brake fails to engage properly.	<p>Electrical control circuit.</p> <p>Valve not functioning properly.</p> <p>Internal pressure leakage.</p> <p>Low hyd. pressure</p>	<p>Check control circuit.</p> <p>Check valve operation. Replace if necessary.</p> <p>Check and replace O-Rings and Liners if necessary.</p> <p>Increase hyd. pressure.**</p>

TROUBLE	POSSIBLE CAUSE	REMEDY
Brake fails to engage properly. (Continued)	Piston sticking. Weak or broken brake spring. Worn friction surfaces.	Disassemble to extent necessary and check for damaged parts. Replace spring. Check parts for wear and replace if necessary. (See Section 6-2)
Brake fails to disengage properly.	Electrical control circuit. Valve not functioning properly. Piston sticking.	Check control circuit. Check and replace valve if necessary. Disassemble to extent necessary and inspect for damaged parts.
Drive overheats. (Oil temp. above 225° F.)	Inertia or resistance changed. Improper oil level. Improper type of oil. Water turned off. Fan blocked.	Check with Force Control engineering. Check oil level. Add or drain as needed. Check name plate and change oil if necessary Check shut-off valve. Clean shroud.
Oil leakage	Oil seal lips damaged. Gaskets Poor ventilation. Seal retainers loose.	Check to see if oil is leaking around shaft and replace if necessary. Tighten all external bolts. Remove breather and clean. Tighten retainer screws.
Oil leakage out breather.	Damaged seal around piston. Oil level too high.	Disassemble and repair. Drain excess oil.
Excessive shaft end play. (.020" Max.)	Bearings bad.	Disassemble and replace.
Clutch or Brake does not repeat	Hydraulic pressure changed Improper type of oil *Oil temperature changed. Resistance in machine changed.	Check hydraulic pressure and adjust. Check name plate and change oil if necessary. Check temperature. Lubricate bearings.

* - For installations requiring precise starting and stopping, operating temperatures are important. Operating temperatures between 116°F and 165°F are recommended. If the oil is allowed to drop to ambient temperatures overnight, the clutch input shaft should be run approximately 1/2 hour before operating the machinery.

** - Max. Hyd. Pressure:
S Logic - 100 PSI ; SA and A Logics - 150 PSI ; B Logic - 161 PSI ; C Logic - 119 PSI ; P Logic - 95 PSI.

Zinc anode - On all water cooled drives, a brass plug containing a zinc anode is installed in the water line close to one of the water connection ports. **DO NOT REMOVE IT.** The zinc anode is installed to prevent electrolysis damage to the oil cooler. Water supply should enter the oil cooler at the port nearest the zinc anode. The zinc anode should be checked occasionally and replaced before it is completely eroded.

6-2 CHECKING THE BRAKE AND CLUTCH STACKS FOR WEAR

(S, SA, A, B and P Logics)

An easy procedure has been established to visually check the Brake and Clutch Stacks for Wear to determine whether or not they need to be replaced.

Four (4) "Stack Wear" Grooves have been machined in the Brake Pressure Plate (#97) Lugs to facilitate this visual check. Depending on which Logic applies to your unit, only (2) of them are used. (See Figure 6.1)

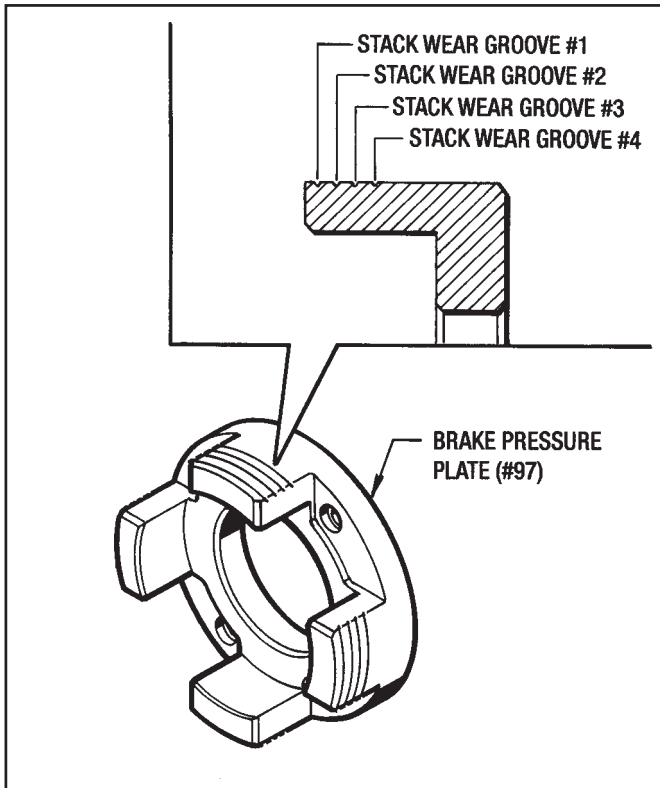

Figure 6.1 - "Stack Wear" Grooves

CAUTION

Disconnect and lock-out all Electrical Power to the Prime Mover. This step must be taken to avoid any possibility of personal injury or damage to the Drive Unit.

6-3 MOTOR DRIVEN HYDRAULIC PUMP UNITS

NOTE: On Piggyback Mounted Units the Drive Motor (#222), Hydraulic Pump (#389) and Motor Mounting Plate (#153) will have to be removed to gain access to the Inspection Ports.

1. Remove the Inspection Plug (#14) from the top of the Output Housing.
2. With the Hydraulic Pump running and with a flashlight observe the position of Surface "A" of the last Drive Plate as shown in Figure 6.2.

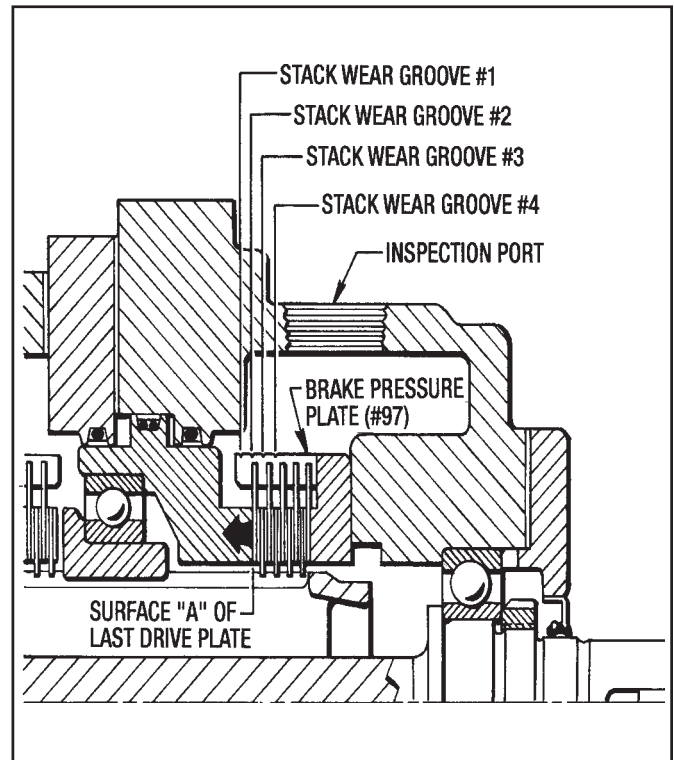

Figure 6.2 - Checking Clutch and Brake Stacks for Wear

A. BRAKE STACK WEAR (See Figure 6.2)

(A, B and SA Logics)

If Surface "A" of the last Drive Plate has moved up to or past the "Stack Wear" Groove (#3), the Brake Stack is worn and needs to be replaced.

(S and P Logics)

If Surface "A" of the last Drive Plate has moved up to or past the "Stack Wear" Groove (#4), the Brake Stack is worn and needs to be replaced.

B. CLUTCH STACK WEAR (See Figure 6.2)

1. Push and hold the "Manual Override" Button on the Control Valve Solenoid (#387).
2. Insert a screwdriver through the inspection port and slide the Brake Stack over to make contact with the piston surface.

(A, B and SA Logics)

If Surface "A" of the last Drive Plate has moved up to or past the "Stack Wear" Groove (#1), the Clutch Stack is worn and needs to be replaced.

(S and P Logics)

If Surface "A" of the last Drive Plate has moved up to or past the "Stack Wear" Groove (#2), the Clutch Stack is worn and needs to be replaced.

Section 7 DISASSEMBLY

7-1 GENERAL DISASSEMBLY PROCEDURE

The EH-2.5 *Posidyne* Clutch/ Brake Unit is comprised of the Input Housing Sub-Assembly and the General Overall Assembly which includes the Clutch Stacks, Piston Retainer, Piston, Brake Stack, Output Housing and Output Shaft.

The Repair Parts Lists and Exploded View Drawings shown in Section 10 are for all Standard and Optional Equipment. They are as follows:

1. EH-2.5 *Posidyne* Clutch/Brake Ass'y (Fig. 10.1)
2. Output C-Face Adapter (8-1/2" AK) (Fig. 10.2)
3. Input Housing Sub-Assembly (Fig. 10.3)
4. Optional Fan Cooling and Water Cooling. (Fig. 10.4)
4. Optional Positioning Encoder Assembly .. (Fig. 10.5)
5. Hydraulic Control Valves (Fig. 10.5)
6. Piggyback Mounting/Motor Driven Pump . (Fig. 10.6)
7. Piggyback Mounting/Pulley Driven Pump (Fig. 10.7)
8. Side Mounting/Motor Driven Pump (Fig. 10.8)

Please refer to these Parts Lists and Exploded View Drawings during the Disassembly Procedure for a visual reference and guide to all parts being disassembled.

NOTES:

1. On Belt Driven or Direct Coupled Units, remove all necessary safety guards, belts, sheaves and couplings.
2. For Water Cooled Units, disconnect water inlet and outlet piping. Drain water from the unit.
3. An overhead crane and a soft sling is also recommended, if necessary, to remove heavy castings and parts.

1. Disconnect the Drive and move it to a suitable work area.
2. Remove drain plugs at the bottom of the Drive Unit and drain out all of the oil into suitable container and either save for reuse or discard as conditions warrants.

(Piggyback Mounting /Motor Driven Pump and Side Mounting/Motor Driven Pump)

(See Figures 10.6 and 10.8)

3. Remove the hydraulic pump, drive motor and all mounting brackets. Also remove all hydraulic hoses and pipe fittings connected to the unit.

(Piggyback Mounting/ Pulley Driven Pump)

(See Figure 10.7)

3. Remove the Belt Guard (#124) by taking out the (4)

Screws (#268) and (4) Lockwashers (#265) in the sides of the Belt Guard.

4. Take the Taper Bushing (#331) off the *Posidyne* Input Shaft. (See Figure 7.1 for procedure.) This will release the tension on the Timing Belt (#334). Take it off the Pulleys.

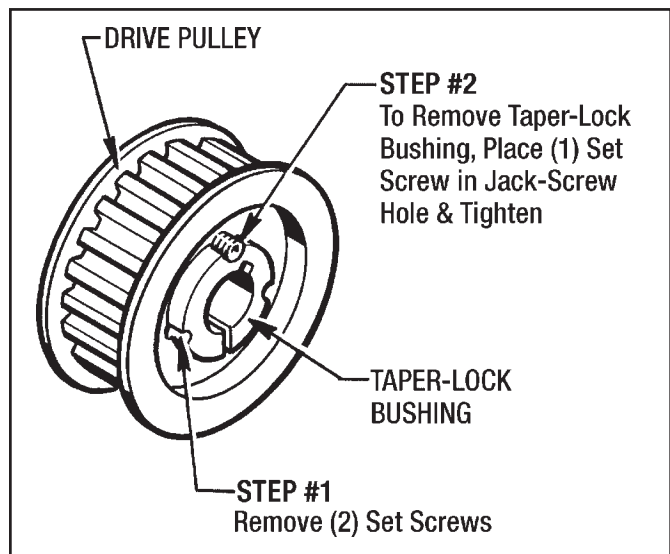

Figure 7.1 - Removing Drive Pulley

5. Disconnect the (2) Hydraulic Hoses from the unit and pump. Remove the attaching Screws (#150) from the Mounting Bracket (#148) and take the bracket and pump assembly off the unit.
6. Remove all other pipe fittings, brackets, filter, etc. that is attached to the *Posidyne* Unit.

7-2 REMOVING HYDRAULIC CONTROL VALVES

(See Figure 10.5)

1. If the Brad Harrison Cable (#902) is still attached to the Control Valve (#387), disconnect it at this time.
2. Remove the (4) Screws (#358) and (4) Lockwashers (#359) and take the Control Valve (#387) off the Manifold (#105).
3. Take the Manifold (#105) off the *Posidyne* Unit by removing the (4) Screws (#198) and (4) Lockwashers (#182).
4. Remove and check the (4) O-Rings (#104) and (1) O-Ring (#103). Replace if necessary.
5. Remove the Pressure Gauges (#327) and Pressure Regulators (#400) from the housing.

NOTE:

There is only (1) Pressure Gauge and (1) Pressure Regulator for Logics "A", "B" and "C".

7-3 REMOVING C-FACE MOUNTED DRIVE MOTOR and C-FACE FLANGES

(With Quill Input Shaft Only)
(See Figure 10.3)

1. Attach an appropriate sling and hoist to the Input Drive Motor for support and removal.
2. Remove (4) Hex Hd. Screws (#415) and (4) Lockwashers (#416) from the C-Face Adapter (#200).
3. Slide the motor shaft out of the Quill Input Shaft (#2).
4. Remove the (4) Soc. Hd. Screws (#201) and (4) Lockwashers (#202) from the C-Face Adapter (#200).
5. Pull the C-Face Adapter (#200) off of the Input Housing.

(With 8-1/2" AK Output C-Face Adapter)
(See Figure 10.2)

1. Remove the (4) Screws (#204) and the (4) Lockwashers (#205) from the C-Face Adapter (#203).
2. Pull the C-Face Adapter (#203) off of the Output Housing.

7-4 REMOVING FAN SHROUD and FAN

(See Figure 10.4)

1. Remove the (2) Screws (#66) from the rear of the Fan Shroud (#24) and remove the Fan Shroud from the Input Housing.
2. Loosen the (2) Set Screws (#70) and pull the Fan (#25) off the Input Shaft (#2).
3. Remove both Keys (#37) and (#180) from the Input Shaft.

7-5 REMOVING POSITIONING ENCODER ASSEMBLY

(See Figure 10.5)

1. If the 5-Pin Brad Harrison Cable (#259) is still attached, disconnect it at this time.
2. Take the Housing Cover (#253) off by removing (4) Screws (#268).
3. Remove the (4) Screws (#76) and (4) Lockwashers (#257) from the Encoder Housing (#17) and pull the housing off the Output Housing.
4. Loosen the Set Screw (#154) and pull the Pulse Gear (#186) off of the Output Shaft (#1).
5. Remove both keys (#181) and (#234) from the Output Shaft.

7-6 REMOVAL OF QUADRATURE SENSOR (#355) and MAGNETIC PICK-UP (#22)

(See Figure 10.5)

NOTE:

The Positioning Encoder Assembly does not have to be removed from the Output Housing to replace the Sensors.

1. Remove the (4) Screws (#225) and take the Top Cover (#372) off the Encoder Housing (#17).
2. Disconnect the wires from the Brad Harrison Cable Connector (#368) to both Sensors.
3. Loosen the Set Screw (#241) and pull the Magnetic Pick-Up (#22) out of the housing. **(Do not remove this set screw.)**
4. Remove the (2) Screws (#226) and lift the Quadrature Sensor (#355) out of the housing.
5. If any Shims (#214) are under this sensor, remove them and save them for Reassembly.

7-7 ACCESS TO THE CLUTCH and BRAKE STACKS

(See Figure 10.1)

We recommend that you set the Drive Unit on the Output End with the Output Shaft in a vertical down position, for ease of disassembly. Supply suitable bracing and clamping to stabilize the Drive Unit for Disassembly.

IMPORTANT NOTE:

When removing the Clutch and Brake Stacks, always keep the Drive Plates and Friction Discs in the same order as they were removed.

A. Clutch Stack

1. Remove the (8) Screws (#69), (2) Screws (#76) and the (10) Lockwashers (#127) from the Output Housing (#9).
2. Using the (2) jackscrew holes in the Input Housing (#8), separate the Input Housing from the Piston Retainer (#11).
3. Remove and discard Gasket (#53).

The Clutch Stack can now be removed from the Output Shaft Spline.

B. Brake Stack *(S, SA, A and B Logics)*

1. Remove the (4) Screws (#62) and (4) Lockwashers (#128) from the Piston Retainer (#11). Using the (2) jackscrew holes, separate the Piston Retainer (#11) from the Output Housing (#9). **Be careful not to damage the Teflon Liner (#42) in the Piston Retainer.**
2. Remove and discard Gasket (#51).
3. Remove the Key (#181) from the Output Shaft (#1).
4. Set the Output Housing upright and remove the (6) Screws (#63) from the Bearing Retainer (#329) located on the output end. Pull the Bearing Retainer (#329) off

the Output Shaft. **Be careful not to damage the lip of the Oil Seal (#31).**

5. Insert a 5/16" allen wrench into the (4) cavities and back-out the Screws (#151). Pull out the Screws (#151), Washers (#264), Springs (#31) and Sleeves (#30). (See Figure 7.2).

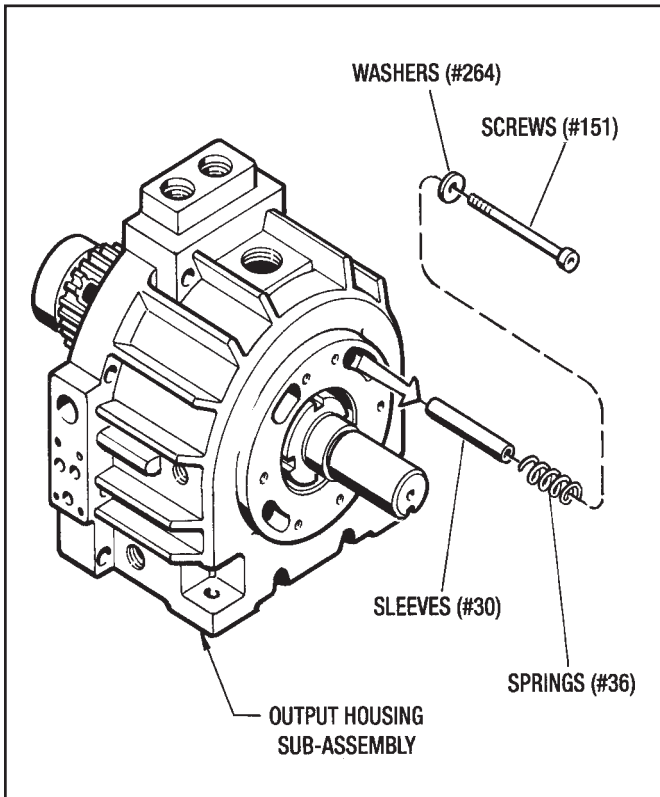

Figure 7.2 - Removing Brake Springs

6. Pull the Piston Sub-Assembly off the Output Shaft Spline and out of the Output Housing. **Be careful not to damage the Teflon Liner (#43) in the Piston.**

The Brake Stack can now be removed from the Output Shaft Spline.

(P Logic - No Springs)

1. Remove the (4) Screws (#62) and (4) Lockwashers (#128) from the Piston Retainer (#11). Using the (2) jackscrew holes, separate the Piston Retainer (#11) from the Output Housing (#9). **Be careful not to damage the Teflon Liner (#42) in the Piston Retainer.**
2. Remove and discard Gasket (#51).
3. Pull the Piston Sub-Assembly off the Output Shaft Spline and out of the Output Housing. **Be careful not to damage the Teflon Liner (#43) in the Piston.**

The Brake Stack can now be removed from the Output Shaft Spline.

7-8 REMOVING PISTON HOUSING ASSEMBLY

(P Logic Only)

1. Remove the (4) Screws (#62) and (4) Lockwashers (#128) from the Piston Retainer (#11). Using the (2) jackscrew holes, separate the Piston Retainer (#11) from the Output Housing (#9). **Be careful not to damage the Teflon Liner (#42) in the Piston Retainer.**
2. Remove and discard Gasket (#51).
3. Remove the Key (#181) from the Output Shaft (#1).
4. Set the Output Housing upright and remove the (6) Screws (#63) from the Bearing Retainer (#329) located on the output end. Pull the Bearing Retainer (#329) off the Output Shaft. **Be careful not to damage the lip of the Oil Seal (#31).**
5. Insert a 5/16" allen wrench into the (4) cavities and back-out the Screws (#76). Pull out the Screws (#76), Washers (#264), Springs (#31) and Sleeves (#30). (See Figure 7.2).
6. Pull the Piston Sub-Assembly off the Output Shaft Spline and out of the Output Housing. **Be careful not to damage the Teflon Liner (#43) in the Piston.**

If replacement of the Clutch and Brake Stacks is the only repair to be done, then proceed to **Section 8 CLEANING and INSPECTION.**

7-9 REMOVING PISTON SEALS (Teflon Liners and O-Rings)

(See Figure 10.1)

It is recommended that all Liners and O-Rings that are removed at Disassembly should be replaced with new ones at Reassembly.

(S, SA, C and P Logics)

1. Remove the Teflon Liner (#42) and O-Ring (#39) from the Output Housing (#9) and discard, if necessary.

(A, B, S, SA and P Logics)

2. Remove the Teflon Liner (#42) and O-Ring (#39) from the Piston Retainer (#11) and discard, if necessary.

(All Logics)

3. Remove the Teflon Liner (#43) and (2) O-Rings (#40) from the Piston (#3) and discard, if necessary.

7-10 PISTON DISASSEMBLY

(See Figures 7.3 and 10.1)

IMPORTANT

Only disassemble this Piston if either the Thrust Plate (#5) or Bearing (#27) needs to be replaced.

1. Press the Thrust Plate (#5) and the Bearing (#27) out of the Piston (#3) with an arbor press as shown in *Figure 7.3*.

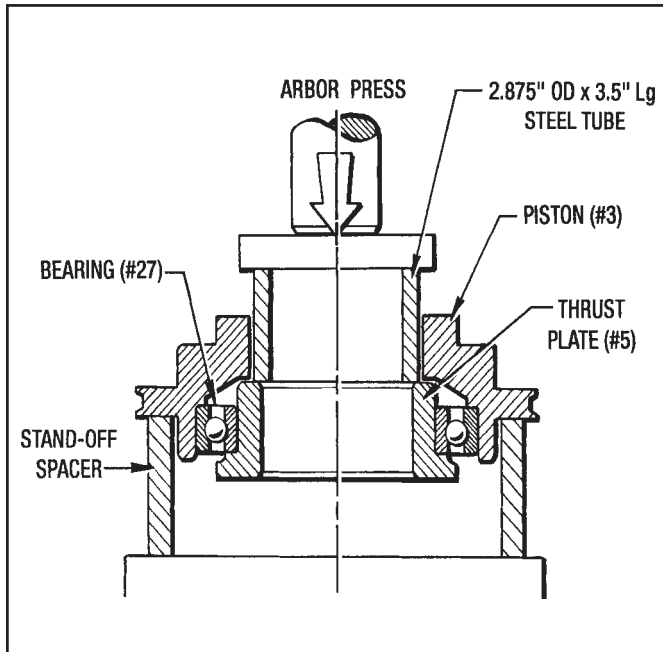

Figure 7.3 - Piston Disassembly

7-11 OUTPUT HOUSING DISASSEMBLY

(See *Figure 10.1*)

(P Logic Only)

1. If the Key (#181) is still in the Output Shaft, remove it at this time.
2. Remove the Bearing Retainer (#329) by taking out (6) Screws (#63). Pull the Bearing Retainer off and over the Output Shaft, **being careful not to damage the lip of Oil Seal (#31)**.

(All Logics)

3. Check the Oil Seal (#31) and if it needs replaced, press it out of the Bearing Retainer (#329) with an arbor press.
4. Remove and discard Gasket (#54).

(All Logics but C Logic)

5. If necessary, remove the Brake Pressure Plate (#97) by taking out (4) screws (#64).

(C Logic Only)

5. Loosen the (3) Set Screws (#130) and take the Spacer (#129) off the Output Shaft Spline. If necessary, remove the (4) Screws (#305) and (4) Lockwashers (#265) and take the Retainer Plate (#302) out of the Output Housing

(All Logics)

6. With a mallet, tap the Output Shaft out of the Output Housing as shown in *Figure 7.4*.

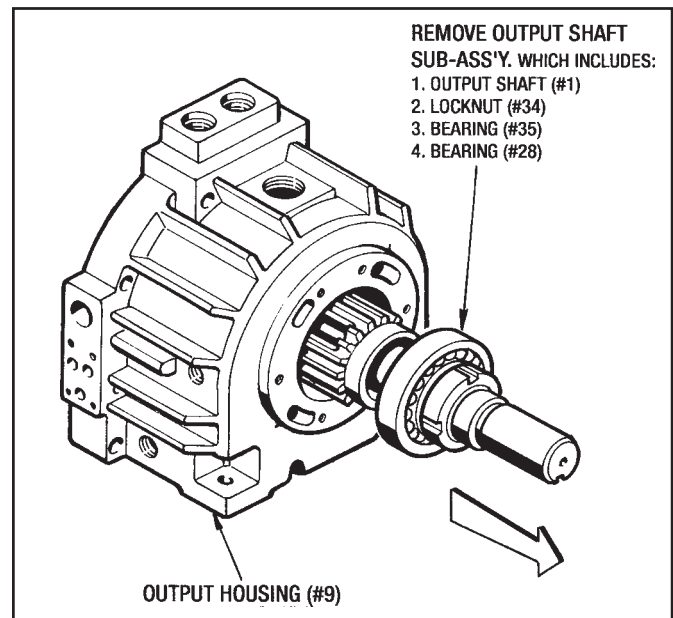

Figure 7.4 - Removing Output Shaft

IMPORTANT

Do not attempt to remove the Output Shaft unless Bearings (#28) and (#35) are damaged and have to be replaced.

7. Heat up the Locknut (#34) and remove it from the Output Shaft. (Also clamp the Output Shaft in a vise to make the disassembly easier.)
8. With a bearing splitter or puller, remove Bearings (#28) and (#35).

7-12 DISASSEMBLY OF INPUT HOUSING SUB-ASSEMBLY

(See *Figure 10.3*)

A. Removing Water Cooled Heat Exchanger

(See *Figure 10.5*)

NOTES:

1. Only remove the Heat Exchanger (#48) if replacement or repair is required.
2. It will be necessary to use a suitable punch to drive the tube ends out of the Input Housing. Care must be taken not to damage external machined surfaces.

1. Remove all external fittings from the Input Housing.
2. Remove (2) Screws (#56).
3. Tap out the tube ends, with a suitable punch, from the Housing (#8) and remove the Heat Exchanger (#48).

B. Removing Male Input Shaft

IMPORTANT

Do not attempt to remove the Input Shaft unless Bearings (#26) and (#38) are damaged and have to be replaced.

1. If the Key (#180) is still intact in the Input Shaft (#2), remove it at this time.
2. Remove (6) Screws (#63) and remove the Bearing Retainer (#7) taking care not to damage the lip of the Oil Seal (#31).
3. Check Oil Seal (#31) and replace if necessary. If replacement is necessary, use an arbor press to press it out of the Bearing Retainer (#7).
4. Remove and discard Gasket (#55).
5. Take the Locknut (#34) off the Input Shaft.
6. Place the Input Housing (#8) into an arbor press with the Input Shaft pointing up. Use appropriate spacers under the housing. Press the Input Shaft (#2) down and out of the housing.
7. Lift the Bearing (#26) out of the bearing bore.
8. Use a Bearing Splitter to remove Bearing (#38) from the Input Shaft. (See Figure 7.5)

3. Check Oil Seal (#208) and replace if necessary. If replacement is necessary, use an arbor press to press it out of the Bearing Retainer (#207).
4. Remove and discard Gasket (#206).
5. Take the Locknut (#209) off the Input Shaft.
6. Place the Input Housing (#8) into an arbor press with the Input Shaft pointing up. Use appropriate spacers under the housing. Press the Input Shaft (#2) down and out of the housing.
7. Lift the Bearing (#26) out of the bearing bore.
8. Use a Bearing Splitter to remove Bearing (#38) from the Input Shaft. (See Figure 7.5)

**Disassembly is now complete for your
EH-2.5 Posidyne Clutch/ Brake Unit**

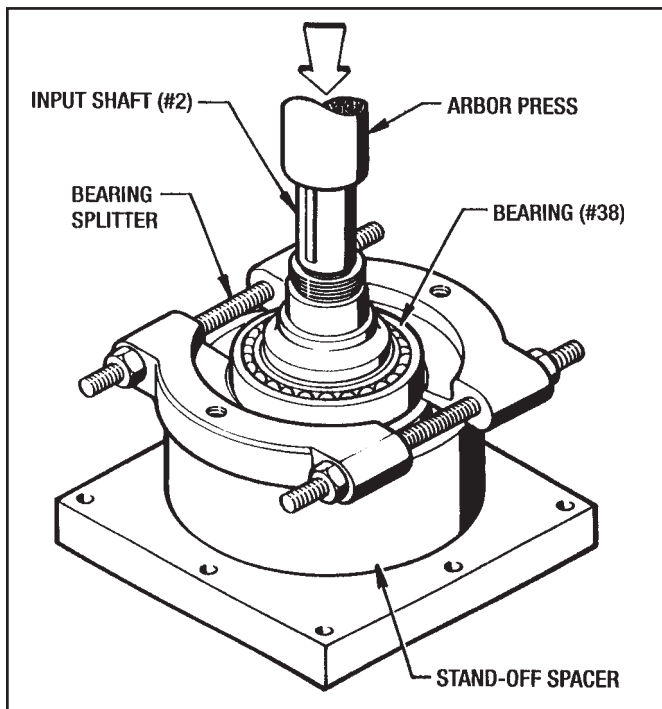

Figure 7.5- Removing Bearings From Input Shaft

C. Removing Quill Input Shaft

IMPORTANT

Do not attempt to remove the Input Shaft unless Bearings (#26) and (#38) are damaged and have to be replaced.

1. If the Key (#180) is still intact in the Input Shaft (#2), remove it at this time.
2. Remove (6) Screws (#110) and remove the Bearing Retainer (#207) taking care not to damage the lip of the Oil Seal (#208).

Section 8

CLEANING and INSPECTION

8-1 CLEANING AND INSPECTION

Clean metal parts in a suitable solvent and dry in a stream of low pressure compressed air. The Clutch and Brake Drive Plates (#13) and (#269) can be cleaned in a solvent, but **DO NOT** clean the Clutch and Brake Friction Discs (#12) in solvent. Use only a clean, dry and lint-free rag to clean these Friction Discs. (Solvent will damage the resilient paper-based friction material used on the Friction Discs). Keep the Drive Plates and Friction Discs in the same order as they were removed. After cleaning, inspect parts for cracks, distortion, scoring, nicks, burrs or other damage would affect serviceability. Pay particular attention to the following:

1. Check the disc wear surfaces for scoring, galling or evidence of uneven wear.
2. Check the clutch and brake plates for scoring or galling. Make sure they are flat. If a perceptible ridge is worn in any of the drive plates, replace all of the drive plates and friction discs as a complete set.
3. Carefully check the piston and bore surfaces for nicks, scratches, scoring or other damage which would affect operation or cause leakage.

4. Pay particular attention to shafts in the area of rotary seals. Check for nicks, scratches which would cause leakage. Replace any damaged parts.
5. It is not necessary to remove the ball bearings to check their operation. Slowly rotate the free race of each bearing by hand checking to see if it turns freely without rough or flat spots.

8-2 REPAIR AND REPLACEMENT

A fine stone or crocus cloth may be used to remove minor surface defects from parts so long as the operating or sealing action of the part is not affected. The use of coarser abrasives or other machining methods should not be attempted. Otherwise, damaged parts should be replaced.

Replacement is recommended also for the following, as applicable:

1. Replace all O-Rings, Liners, Gaskets and Oil Seals removed during the course of disassembly.
2. Replace Clutch or Brake Discs and Drive Plates in complete sets only.

Section 9

REASSEMBLY

9-1 GENERAL REASSEMBLY INSTRUCTIONS

1. Lubricate O-Rings and the lips of all the Oil Seals with the same oil as used in the Drive Unit immediately before Reassembly and Installation of any mating parts.
2. O-Ring Liners (#43) will be easier to install if heated in an oven to 250° F. maximum.

The installation of press fitted parts can be eased by heating the outside parts in an oven. Heat Bearings to 250° F. maximum. **Always wear suitable gloves when handling heated parts.**
3. Apply Gasket Sealant (Permatex #30), or equivalent, to all flat gaskets except where otherwise noted.
4. Use Cap Screw Adhesive (Loctite #271), or equivalent, on all Cap Screws and Locknuts. Use sparingly and clean off any excess with (Loctite (#755) Adhesive Cleaner.
5. Unless otherwise specified, torque all bolts to **SAE Grade 5** specifications.

Basically the Reassembly is just a reverse order of the Disassembly Procedure described in Section 7.

9-2 REASSEMBLY OF INPUT HOUSING SUB-ASSEMBLY

(See Figure 10.3)

A. Installing Male Input Shaft

1. Press Bearing (#38) onto the Input Shaft (#2) with an arbor press.
2. Insert the Input Shaft (#2) with the Bearing (#38) on it into the rear of the Input Housing (#8) until the Bearing (#38) seats in the bearing bore.
3. Set the Input Housing into an arbor press as shown in Figure 9.1. Place the Bearing (#26) onto the Input Shaft with the bearing loading slots up. With an appropriate sized tube, as shown, press on the inner race of the bearing until it bottoms out. **(Do not press on the bearing cage of the outer race.)**
4. Install Locknut (#34) onto the Input Shaft (#2). Use Thread-Locker (Loctite #271) on the threads. **Wipe off any excess.**

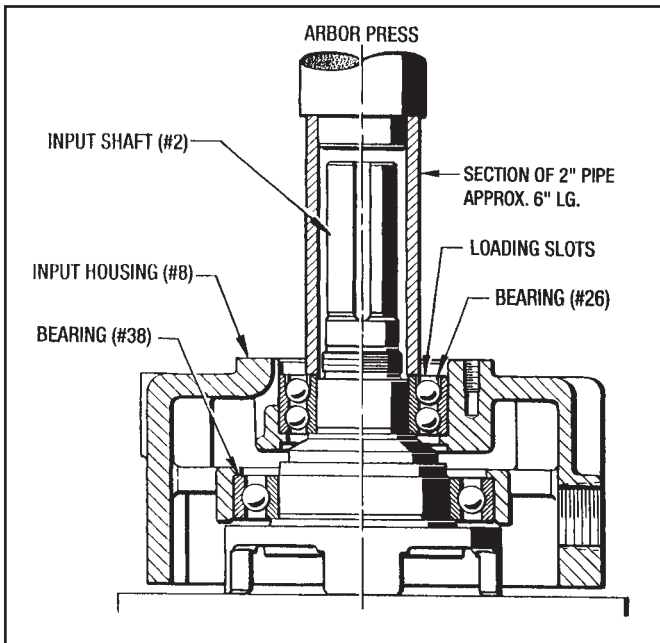

Figure 9.1 - Installing Male Input Shaft

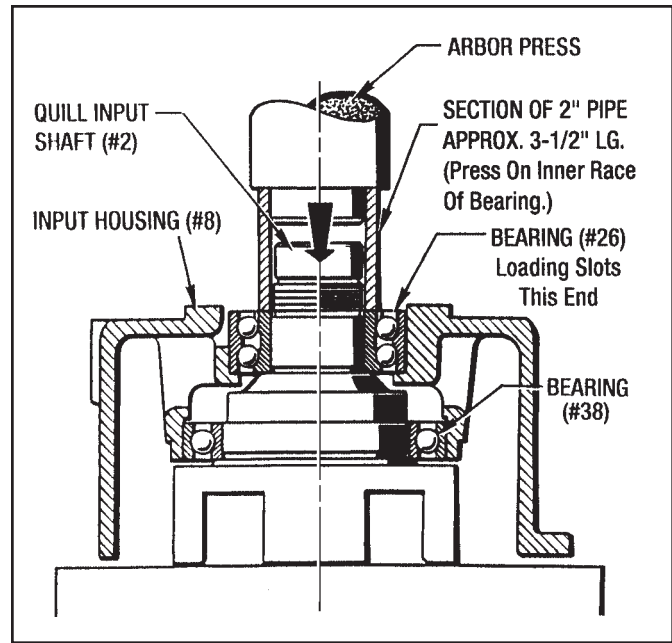

Figure 9.2- Installing Quill Input Shaft

5. Apply a thin coat of Sealant (Permatex #30) to the oil seal bore in the Bearing Retainer (#7) or (#16) and press the Oil Seal (#31) into the bore.
6. Place the Gasket (#55) onto the Bearing Retainer (#7), aligning the screw holes up. **(Do not use any gasket sealant on this gasket.)**
7. Place masking tape over the keyway and slide the Bearing Retainer (#7) or (#16) with the Gasket (#55) over the shaft, being careful not to damage the lip of the Oil Seal (#31). Attach with (6) Screws (#63). **Torque to 9 Ft. Lbs.**
8. Replace Key (#180) back into the Input Shaft.

B. Installing Quill Input Shaft

1. Press Bearing (#38) onto the Input Shaft (#2) with an arbor press.
2. Insert the Input Shaft (#2) with the Bearing (#38) on it into the rear of the Input Housing (#8) until the Bearing (#38) seats in the bearing bore.
3. Set the Input Housing into an arbor press as shown in Figure 9.2. Place the Bearing (#26) onto the Input Shaft with the bearing loading slots up. With an appropriate sized tube, as shown, press on the inner race of the bearing until it bottoms out. **(Do not press on the bearing cage of the outer race.)**
4. Install Locknut (#209) onto the Input Shaft (#2). Use Thread-Locker (Loctite #271) on the threads. **Wipe off any excess.**
5. Apply a thin coat of Sealant (Permatex #30) to the oil seal bore in the Bearing Retainer (#207) and press the Oil Seal (#208) into the bore.

6. Place the Gasket (#206) on to the Bearing Retainer (#207), aligning the screw holes up. **(Do not use any gasket sealant on this gasket.)**
7. Slide the Bearing Retainer (#207) with the Gasket (#206) over the shaft, being careful not to damage the lip of the Oil Seal (#208). Attach with (6) Screws (#210). **Torque to 14 Ft. Lbs.**
8. Replace Key (#180) back into the Input Shaft.

9-3 INSTALLING WATER COOLED HEAT EXCHANGER (See Figures 9.3 and 10.4)

1. Guide the Heat Exchanger (#48) into the Input Housing, making sure that the tube ends project out the (2) holes in the rear face of the Housing. Attach with (2) Screws (#56).
2. Mark the tubing approximately 1/16" beyond the face of the housing. (See Figure 9.3).
3. Remove the Heat Exchanger from the Housing and cut off the tubes on the 1/16" marks. **NOTE:** The ends of the tubes must be free of all burrs before reassembly.
4. Reinstall the Heat Exchanger back into the Housing. Apply Loctite #271 to the tubing O.D. Then place the (2) Compression Fittings with Ferrules (#71) on the tubing. (See Figure 9.3).

IMPORTANT

When tightening Fittings (#71), do not over-tighten and then back off. This will cause the compression seal to leak.

5. Install all external pipe fittings shown on Figure 10.5.

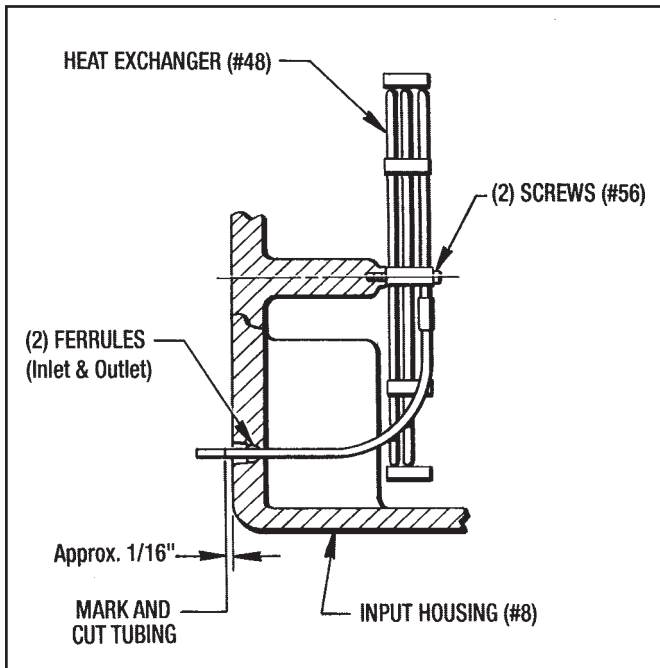

Figure 9.3 - Installing Water Cooled Heat Exchanger

9-4 OUTPUT HOUSING INSTALLATION

(See Figure 10.1)

1. Install both Bearings (#28) and (#35) onto the Output Shaft (#1) with an arbor press.
2. Next install the Locknut (#34) onto the Output Shaft. Use (Loctite #271) on the threads. **Wipe off any excess.**
3. Insert the Output Shaft with the (2) Bearings on it into the Output Housing (#9) until Bearing (#35) seats into the bearing bore. (See Figure 9.4)

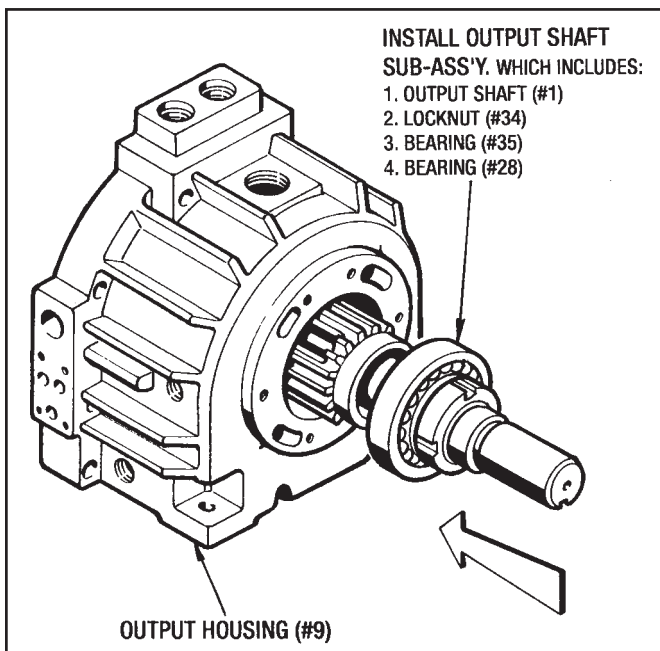

Figure 9.4 - Installing Output Shaft

(P Logic Only)

4. Press the Oil Seal (#31) into the Bearing Retainer (#329). Install the Gasket (#54) and Bearing Retainer (#329) on to the Output Housing (#9). **Do not use any Gasket Sealant on this gasket. Also be careful not to damage the lip of Oil Seal (#31) on the output shaft keyway.**

(All Logics but P Logic)

4. Temporarily attach the Bearing Retainer (#329) to the Output Housing (#9) with (2) Screws (#63). **Do not tighten these screws at this time.**

Then set the Output Housing in a vertical position with the output shaft down.

(All Logics except C Logic)

5. Attach the Brake Pressure Plate (#97) to the inside of the Output Housing with (4) Screws (#64). **Torque to 14 Ft. Lbs.**
6. Install the Brake Stack onto the Output Shaft Spline (#1) and Brake Pressure Plate (#97). Start with a Drive Plate (#269) then a Friction Disc (#12), ending with a Drive Plate (#269).

Align the notches in the Drive Plate (#269) with the lugs on the Brake Pressure Plate (#97) and the internal teeth in the Friction Discs (#12) with the splined teeth on the Output Shaft (#1).

(C Logic Only)

5. Slide the Spacer, Spider (#129) on to the spline of the Output Shaft (#1). Position the end of the Spacer (#129) .50" from the face of the Output Housing. Tighten (3) Set Screws (#130). (See Figure 9.5)
6. Attach the Retainer Plate (#302) to the inside of the Output Housing with (2) Screws (#305) and (2) Lockwashers (#265) in the (2) bottom holes.

Place the Splash Guard (#196) on the Retainer Plate (#302) and attach with the other (2) Screws (#305) and (2) Lockwashers (#265). **Torque all (4) Screws to 14 Ft. Lbs.**

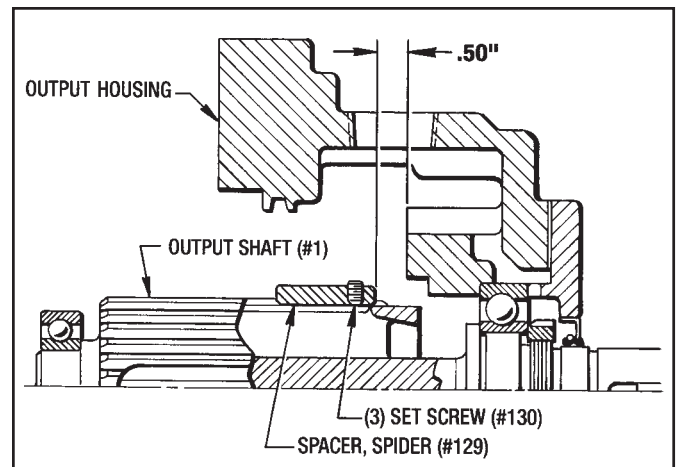

Figure 9.5 - Installing Spacer, Spider (C Logic Only)

9-5 REASSEMBLY OF PISTON SUB-ASSEMBLY

(See Figure 10.1)

1. Apply Sealant (Loctite #620) to the I.D. of Bearing (#27) and press it onto the Thrust Plate (#5). Make sure that the Bearing is firmly seated on the Thrust Plate shoulder.
2. Apply Sealant (Loctite #620) to the O.D. of Bearing (#27). Press the Bearing and Thrust Plate into the Piston (#3). Again, make sure the bearing is firmly seated in the Piston.

(S, SA and P Logics Only)

3. Lubricate the (2) O-Rings (#40) and install them on the Piston (#3).
4. Heat the Teflon Liner (#43) to 200° F. max. and install it on the Piston (#3). Also lubricate this Liner before installing it.

CAUTION

Use suitable work gloves when handling heated parts.

9-6 INSTALLING PISTON SUB-ASSEMBLY and SPRINGS (See Figures 9.6, 9.7 and 10.1)

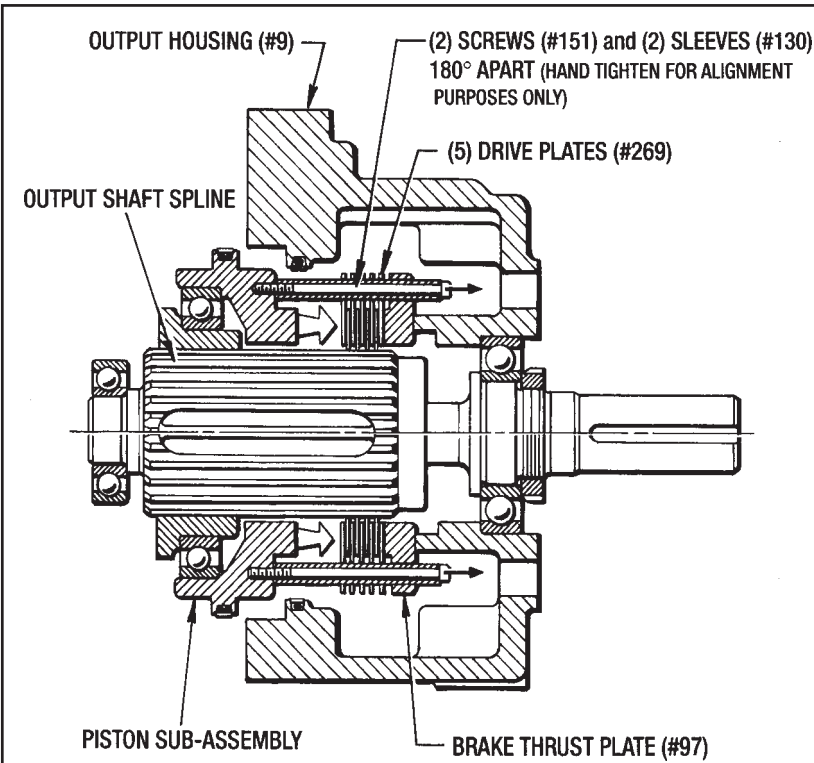

1. Lubricate the O-Ring (#39) and the Teflon Liner (#42) and install them into the Output Housing (#9).

(All Logics except P Logic)

2. Set the unit upright and take the Bearing Retainer (#329) back off the Output Housing.
3. For ease of installation, attach (2) Screws (#151) and (2) Sleeves (#30) to the Piston (#3). **Only hand tighten these screws. Do not install the Springs (#36) or the Washers (#264).**
4. Insert the Piston Sub-Ass'y. down over the Output Shaft Spline and into the Output Housing. Align the (2) Screws (#151) and (2) Sleeves (#30) with the holes in the Drive Plates (#269). **Be careful not to damage the installed Liners (#42) and (#43).** (See Figure 9.6)
5. Remove the (2) Screws (#151) previously installed in the Piston for alignment. Reinstall the proper amount of Sleeves (#30), Springs (#36), Washers (#264) and Screws (#151). (See Figure 9.7 for placement and quantities needed for the different logics.)

Figure 9.6 - Piston Alignment

SA, A and B Logics

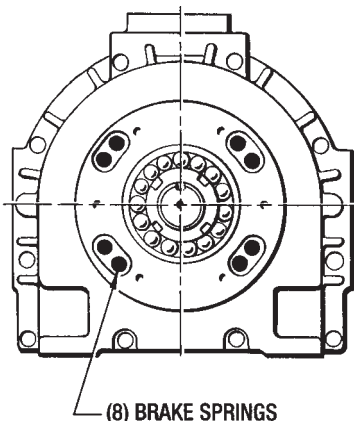

S Logic

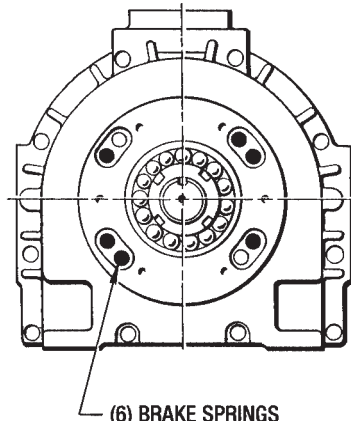

C Logic

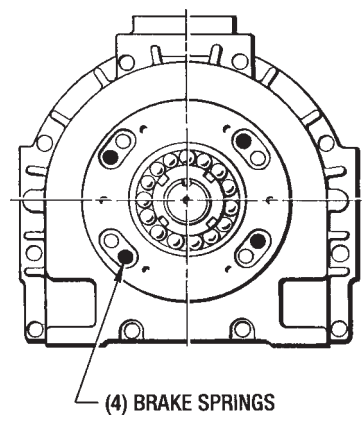

Figure 9.7 - Spring Placement and Quantities

(P Logic Only)

2. Insert the Piston Sub-Ass'y. down over the Output Shaft Spline and into the Output Housing. Align the (2) Pins (#218) with the the slots in the Brake Pressure Plate (#97). **Be careful not to damage the installed Liners (#42) and (#43).**

9-7 INSTALLING PISTON RETAINER

(See Figure 10.1)

1. For ease of further installation, set the unit back to a vertical position with the output shaft in the down position.
2. Lubricate the O-Ring (#39) and the Teflon Liner (#42). Install them into the Piston Retainer (#11). **NOTE:** This O-Ring and Liner is not used for C Logic.
3. Place the Gasket (#51) onto the Output Housing (#9), using the Dowel Pin (#68) to assure proper alignment. **Use Gasket Sealant (Permatex #30). Wipe off any excess.**
4. Push the Piston Retainer (#11) down and over the Piston (#3) and onto the Output Housing. **Be careful not to damage the Teflon Liner (#42) (if used) in the Piston Retainer.**
5. Attach with (4) Screws (#62) and (4) Lockwashers (#128).

IMPORTANT

Compress these (4) Screws in an even manner to compress the Springs (#36) correctly. Torque to 14 Ft. Lbs.

9-8 INSTALLING CLUTCH STACK

(See Figure 10.1)

1. Install the Clutch Stack onto the Output shaft spline, starting with a Friction Disc (#12), then a Drive Plate (#13) ending with a Drive Plate (#13). There are (4) Friction Discs and (4) Drive Plates.

Align the notches in the Drive Plates with each other and align the internal teeth in the Friction Discs with the spline in the Output Shaft.

9-9 INSTALLING INPUT HOUSING SUB-ASSEMBLY

(See Figure 10.1)

1. Place the Gasket (#53) on the Piston Retainer (#11), using the (2) Pins (#68) for alignment. Use (Permatex #30) Gasket Sealant. **Wipe off any excess.**
2. Lower the Input Housing Sub-Assembly down onto the Piston Retainer, aligning the lugs on the Input Shaft (#2) with the notches in the Drive Plates (#13). Press the Input Housing down until the (2) Dowel Pins (#68) engage the Input Housing. Make sure that Gasket (#53) stays in position.

CAUTION

Do not force the Input Shaft Lugs into the Clutch Stack. This could damage the Drive Plates. Lower the Input Housing slowly and, if necessary, manually adjust the Drive Plates.

3. With the (8) Screws (#69), (2) Screws (#76) and (10) Lockwashers (#127) bolt the Housings together. Use (Loctite #271) Thread- Locker on the threads. **Torque to 14 Ft. Lbs.**
4. If your Drive Unit has a Male Input Shaft, but does not have Fan Cooling, install Key (#180) into the Input Shaft (#2).

9-10 INSTALLING HYDRAULIC

CONTROL VALVE *(See Figure 10.5)*

1. Install the Pressure Regulators (#400) into the top of the output housing. **NOTE:** There are (2) Valves for S, SA and P Logics and only (1) valve for A, B and C Logics. The Brake Port is plugged with O-Ring (#228) and Plug (#409).
2. Lubricate and install the (4) O-Rings (#104) and (1) O-Ring (#103) into the Manifold (#105).
3. Mount the Manifold (#105) on to the side of the output housing with (4) Screws and (4) Lockwashers (#182).
4. Install the Relief Valve (#388) into the top of the Manifold (#105).
5. Attach the Control Valve (#901) to the Manifold with (4) Screws (#198) and (4) Lockwashers (#182).
6. Replace any pipe plugs in the manifold that were removed at dis-assembly.

Before proceeding any further an **Operational Check of the Piston Movement should be made.** Apply 60 to 80 PSI as indicated in Section 5 - Operational Checks. Observe the piston movement through the inspection ports.

9-11 INSTALLING POSITIONING

ENCODER ASSEMBLY

(See Figure 10.5)

1. Replace Key (#234) into the *Posidyne* output shaft if it was removed.
2. Slide the Pulse Gear (#186) onto the output shaft and tighten Screw (#154).
3. Slide the Housing (#17) over the Pulse Gear (#186) and attach it to the *Posidyne* Output Housing with (2) Screws (#76) and (2) Washers (#257).

Jump ahead to Section 9-12 and install the Quadrature Encoder (#355) and the Magnetic Pick-Up (#22).

- Attach the Top Cover (#372) with (4) Screws (#225) and the Front Cover (#253) with (4) Screws (#268).

9-12 INSTALLING QUADRATURE ENCODER (#355) AND MAGNETIC PICK-UP (#22)

(See Figure 10.5)

Before installing the Quadrature Encoder and Magnetic Pick-Up a special .015" Shim must be made to set the Gap between them and the Pulse Gear. (See Figure 9.8)

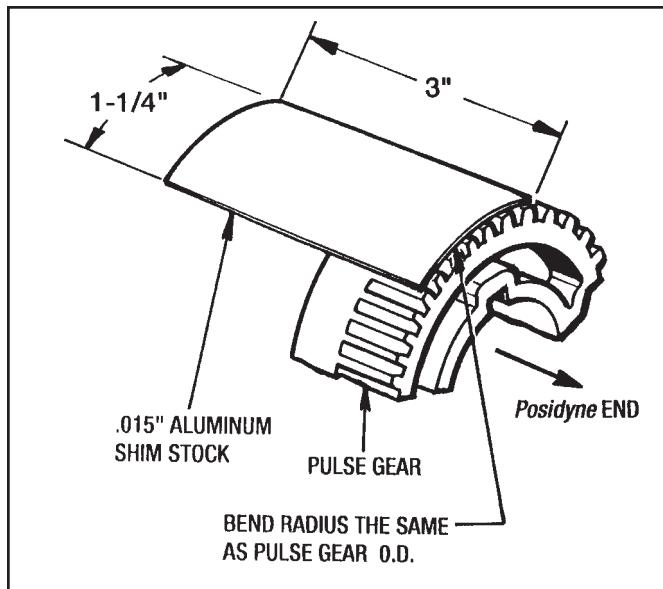

Figure 9.8 - Sensor Gap Shim

A. QUADRATURE ENCODER (See Figure 9.9)

- Looking through the hole where the Encoder is to be placed, check to see that the Pulse Gear (#186) is in position so the teeth will be aligned with the Encoder.

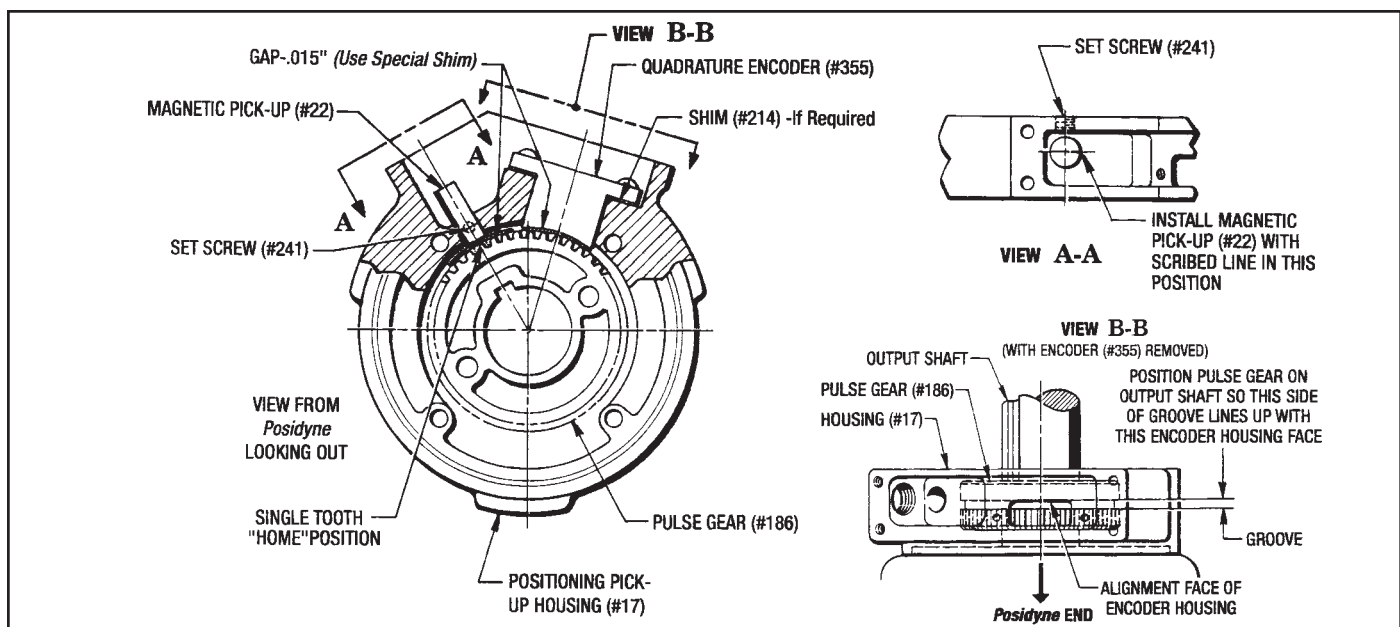

Figure 9.9 - Position Sensors Installation

- Position the Encoder so the (2) mounting holes are lined up with the holes in the housing. Insert the Sensor into the slot and attach with (2) Screws (#226).

NOTES:

- The holes are offset to one side so the Encoder can only be installed one way.
- Do not install any Shims (#214) at this time. **The Gap must be checked first.**
- Check the Gap between the Pulse Gear and the Encoder with the Special .015" Shim that you made. If necessary, remove the Encoder and place Shims (#214) under the Encoder. (Usually .015" is sufficient.) Re-attach the Encoder and re-check the Gap. (See Figure 9.9)
- Connect the sensor wires to the Brad Harrison Connector.

B. MAGNETIC PICK-UP SENSOR (See Figure 9.9)

- Visually check through the hole to see if the single tooth in the Pulse Gear (#186) is aligned with the Sensor and that the teeth for the Quadrature Encoder will not be visible to the Magnetic Pick-Up Sensor.

The Magnetic Pick-Up Sensor has a **Scrubed Line** down one side of it. To facilitate installation, highlight this **Scrubed Line** with a felt tip pen.

- Insert the Magnetic Pick-Up Sensor (#22) into the hole with the **Scrubed Line** in position as shown in Figure 9.9, View A-A.
- Insert the special .015" Shim in between the Pulse Gear and the Sensor. Tighten the Set Screw (#241).
- Connect the sensor wires to the Brad Harrison Connector.

9-13 INSTALLING FAN AND FAN SHROUD

(See Figure 10.4)

1. Install Key (#37) into the Input Shaft.
2. Place Fan (#25) on the Input Shaft and tighten the (2) Set Screws (#70).
3. Place the Fan Shroud (#24) into position and attach with (2) Screws (#66).
4. Install Key (#180) into the Input Shaft.

9-14 ATTACHING C-FACE ADAPTERS

A. Output C-Face Adapter

(See Figure 10.2)

1. Attach the C-Face Adapter (#203) with (8) Screws (#204) and (8) Lockwashers (#205). **Torque to 25 Ft. Lbs.**

B. Input C-Face Adapters

(With Quill Input Shaft Only)

(See Figure 10.3)

1. Attach C-Face Adapter (#200) with (6) Screws (#201) and (6) Lockwashers (#202). **Torque to 25 Ft. Lbs.**

9-15 FINAL REASSEMBLY

(See Figure 10.6)

(Piggyback Mounting/Motor Driven Pump)

1. Re-attach Mounting Brackets, Hydraulic Pump, Drive Motor Assembly.
2. Re-connect the Hydraulic Filter and all Hydraulic Fittings, Hoses and Pipe Plugs removed for Inspection or Disassembly.

(Piggyback Mounting/Pulley Driven Pump)

1. Re-attach the Pump Mounting Bracket (#148) and the Hydraulic Pump (#389).

2. Place the Pulley (#332) with the Taper Bushing (#330) on the pump shaft. Place the Pulley (#333) with the Taper Bushing (#331) on the *Posidyne* input shaft. **Do not tighten them at this time.**
3. Install the Timing Belt (#334) on the pulleys.
4. Now tighten both Taper Bushings as shown in *Figure 9.11*.
5. Replace the Belt Guard (#124).
6. Re-connect the Hydraulic Filter and all Hydraulic Fittings, Hoses and Pipe Plugs removed for Inspection or Disassembly.

(Side Mounting/ Motor Driven Pump)

1. Re-mount the Hydraulic Pump and Drive Motor if it was removed.
2. Re-connect the Hydraulic Filter and all Hydraulic Fittings, Hoses and Pipe Plugs removed for Inspection or Disassembly.

(All Units)

1. Fill the Drive Unit with Mobil Automatic Transmission Fluid type ATF-210 type "F" or Mobil Multi-purpose Automatic Transmission Fluid, as indicated in **Section 4 LUBRICATION.**

IMPORTANT:

Other fluids may be specified for special drives. First Check the Name Tag.

2. Replace all external motor drive parts, safety guards, sheaves, pulleys, belts and couplings on belt drive units.

REASSEMBLY IS NOW COMPLETE AND THE DRIVE UNIT IS READY FOR SERVICE.

Section 10

ILLUSTRATED PARTS LIST

10-1 GENERAL INFORMATION

This section illustrates, lists and describes all available repair parts for the Force Control EH-2.5 *Posidyne* Clutch/ Brake Drives. Parts are identified on the exploded views with Part Reference Numbers. These Numbers correspond to the Part Reference Number given in the Parts List. The Part Name and Quantity Used is also given in the Parts List. This Part Reference Number, Part Name and Quantity should be used when ordering parts.

10-2 DRIVE MOTORS

The motors used with these Drive Units are standard and may be repaired or replaced by any qualified motor rebuild facility or supplier.

10-3 FACTORY REBUILD SERVICE

Reconditioning service is offered by Force Control Industries at the factory. Unless major parts (such as housing, shafts, piston, etc.) are damaged, the cost of complete factory rebuild will be 50% the cost of a new unit. Before returning a unit for this service, however, be sure to first contact the Force Control Industries Service Sales Department for authorization and shipping instructions. Force Control Industries cannot be responsible for units returned to the factory without prior notice and authorization.

Care must be given to the packing of return drives. Always protect mounting feet by attaching to a skid. Shipment-damaged drives always delay repairs. It is usually impossible to recover damage costs from the carrier. When possible describe the problem experienced on your shipping papers.

Return to: **Force Control Industries, Inc.**
3660 Dixie Highway
Fairfield (Hamilton), Ohio 45014
Telephone: 513-868-0900
Fax No.: 513-868-2105

10-4 ORDERING REPLACEMENT PARTS

When ordering replacement parts, please specify all of the following information:

1. **Drive Model Number** (on the nameplate)
2. **Drive Serial Number** (on the nameplate)
3. **Part Reference Number** (from the parts list or exploded view drawing.)
4. **Part Name** (from the parts list)
5. **Quantity** (from the parts list)
6. **Complete Shipping Information**

Failure to include information for items 1 thru 6 will only delay your parts order. Unless another method is specified for item 6, parts less than 150 pounds will be shipped United Parcel Service, parts over 150 pounds will be shipped Motor Freight. Air freight and other transportation services are available but only if specified on your order.

10-5 NAME PLATE AND MODEL NUMBERS

The Name Plate shown is located on the Housing.

Force Control Industries, Inc.	
Fairfield, Ohio	
	<i>For Service / Parts Call</i>
513-868-0900	
Posidyne[®] Clutch/Brake	
Model No.	<input type="text"/>
Serial No.	<input type="text"/>
Use Mobil[®] ATF 210	

NOTES:

Repair Parts List - (Figure 10.1)
EH-2.5 Posidyne CLUTCH/BRAKE ASSEMBLY

REF. No.	PART NAME	QTY.	REF. No.	PART NAME	QTY.
1	Output Shaft	1	*54	Gasket, Bearing Retainer	1
3	Piston	1	62	Soc. Hd. Cap Screw	4
**5	Thrust Plate	1	63	Soc. Hd. Cap Screw	6
9	Output Housing	1	64	Soc. Hd. Cap Screw (Not used on C logic).	4
11	Piston Retainer	1	68	Dowel Pin	2
*12	Friction Disc		69	Soc. Hd. Cap Screw	8
	A,B,S,SA and P Logics	8	72	Pipe Plug	1
	C Logic	4	73	Pipe Plug	2
*13	Drive Plate	4	76	Soc. Hd. Cap Screw	2
14	Inspection Plug	1	90	Reducer Bushing	1
*27	Bearing, Piston	1	97	Brake Pr. Plate (Not used on C logic).	1
*28	Bearing, Pilot	1	116	Filler Drive Plate (Not on C logic)	AR
30	Sleeve (Not used on P logic)		122	Dowel Pin (Not used on C logic).	2
	S Logic	6	127	Lockwasher	10
	SA, A and B	8	128	Lockwasher	4
	C Logic	4	129	Spacer, Spider (C Logic Only)	1
*31	Oil Seal	1	130	Set Screw (C Logic Only)	3
**34	Locknut	1	136	Pipe Plug	2
*35	Bearing, Output Shaft	1	151	Soc. Hd. Cap Screw (Not used on P logic)	
*36	Spring (Not used on P logic)			S Logic	6
	S Logic	6		SA, A and B	8
	SA, A and B	8		C Logic	4
	C Logic	4	181	Key	1
*39	O-Ring		196	Splash Guard (C Logic Only)	1
	A,B and C Logics	1	218	Pin (P Logic Only)	1
	S, SA and P Logics	2	264	Flat Washer (Not used on P logic)	
*40	O-Ring	2		S Logic	6
*42	Teflon Liner, I. D. Sealing			SA, A and B	8
	A,B and C Logics	1		C Logic	4
	S, SA and P Logics	2	265	Lockwasher (C Logic Only)	4
*43	Teflon Liner, O.D. Sealing	1	*269	Drive Plate (Not used on C Logic)	5
**45	Breather	1	302	Retainer Plate (C Logic Only)	1
**46	Sight Gauge	1	305	Cap Screw (C Logic Only)	4
*51	Gasket, Output Housing	1	329	Bearing Retainer	1
*53	Gasket, Input Housing	1	380	Filler Drive Plate	AR

* - Indicates parts in Minor Overhaul Kit.

** - Indicates parts in Major Overhaul Kit. (Plus all parts in the Minor Overhaul Kit.)

AR - As Required

EH-2.5 Posidyne CLUTCH/BRAKE ASSEMBLY

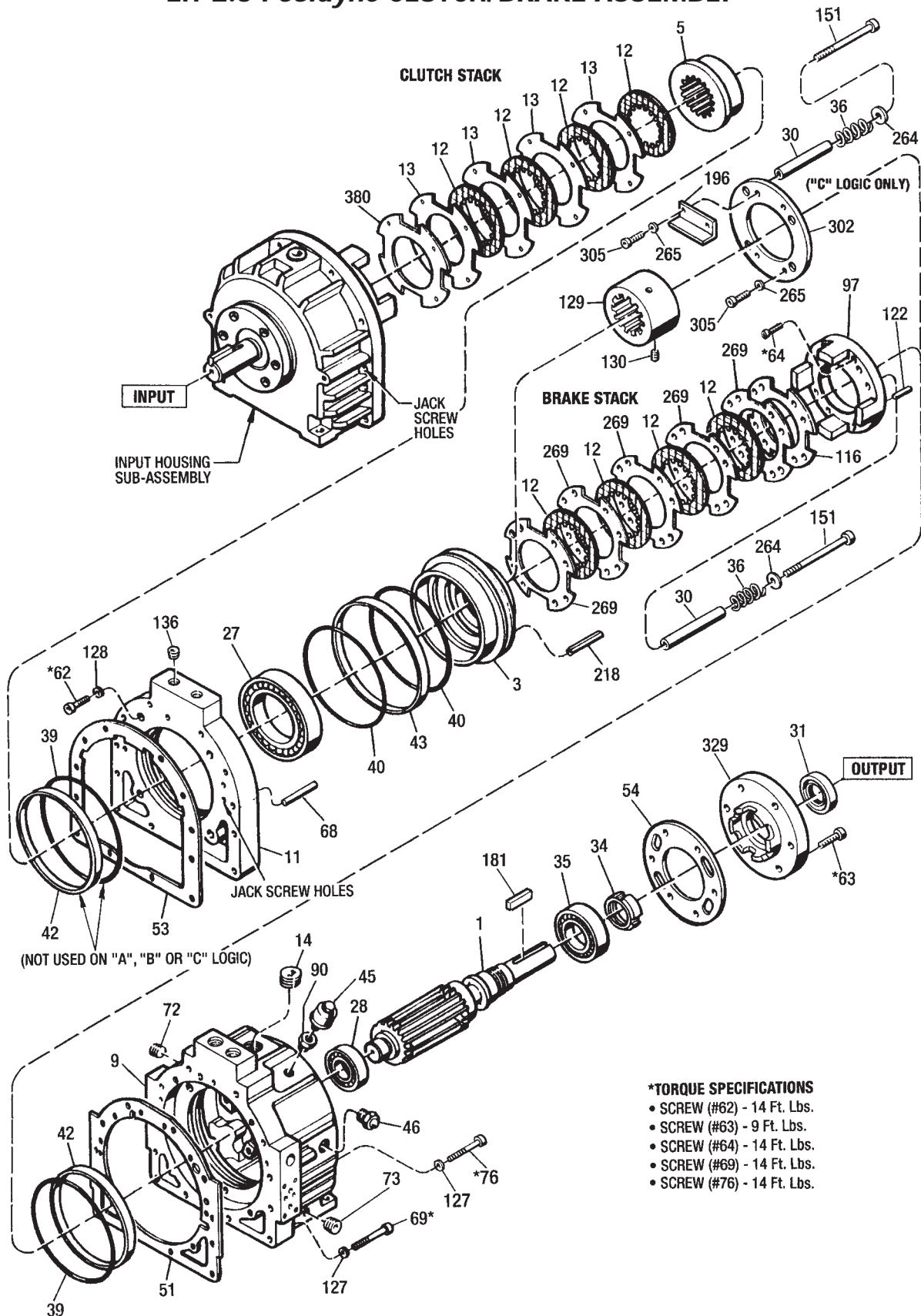

Figure 10.1- EH-2.5 Posidyne Clutch/Brake Assembly

Repair Parts List - (Figure 10.2) & (Figure 10.3)
OUTPUT C-FACE ADAPTER
INPUT HOUSING SUB-ASSEMBLY

REF. No.	PART NAME	QTY.	REF. No.	PART NAME	QTY.
2	Input Shaft	1	200	C-Face Flange, Input	1
7	Bearing Retainer (With Motor Driven Pump)	1	201	Soc. Hd. Cap Screw	6
8	Input Housing	1	202	Lockwasher	6
14	Pipe Plug	1	203	C-Face Flange, Output	1
16	Bearing Retainer (With Pulley Driven Pump)	1	204	Soc. Hd. Cap Screw	8
*26	Bearing	1	205	Lockwasher	8
*31	Oil Seal	1	*206	Gasket	1
**34	Locknut	1	207	Bearing Retainer	1
*38	Bearing	1	*208	Oil Seal	1
*55	Gasket	1	**209	Locknut	1
63	Soc. Hd. Cap Screw	6	210	Soc. Hd. Cap Screw	6
99	Freeze Plug	1	415	Hex. Hd. Cap Screw	4
104	O-Ring	1	416	Lockwasher	4
180	Key	1			

* - Indicates parts in Minor Overhaul Kit.

** - Indicates parts in Major Overhaul Kit (Plus all parts in the Minor Overhaul Kit).

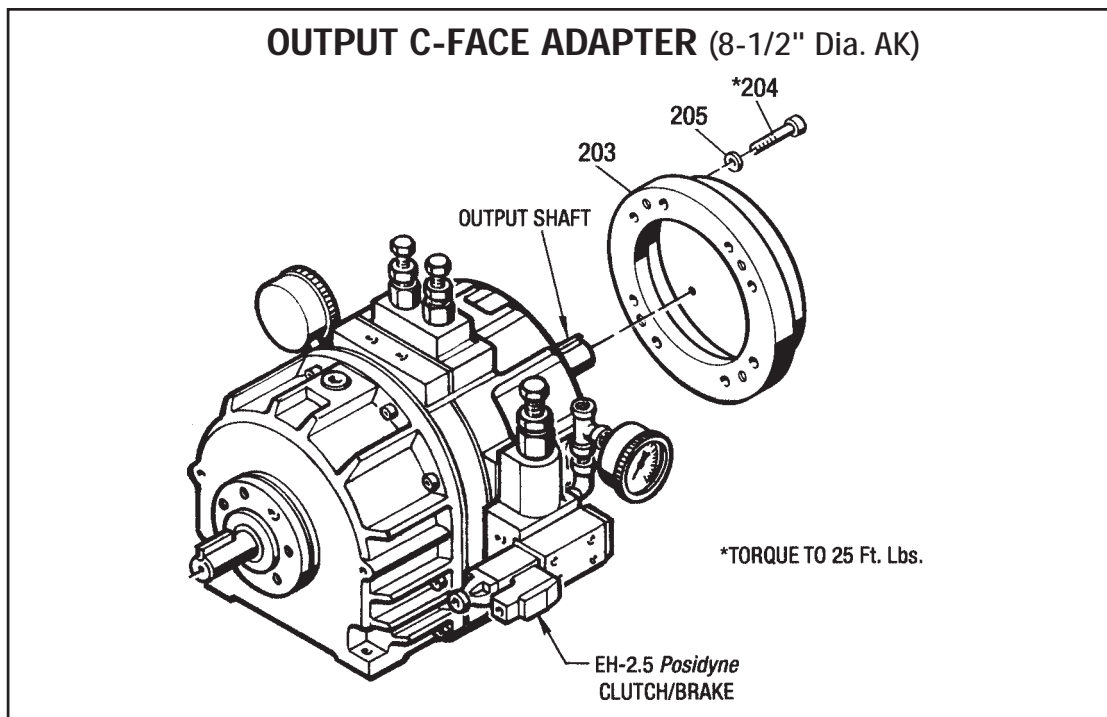
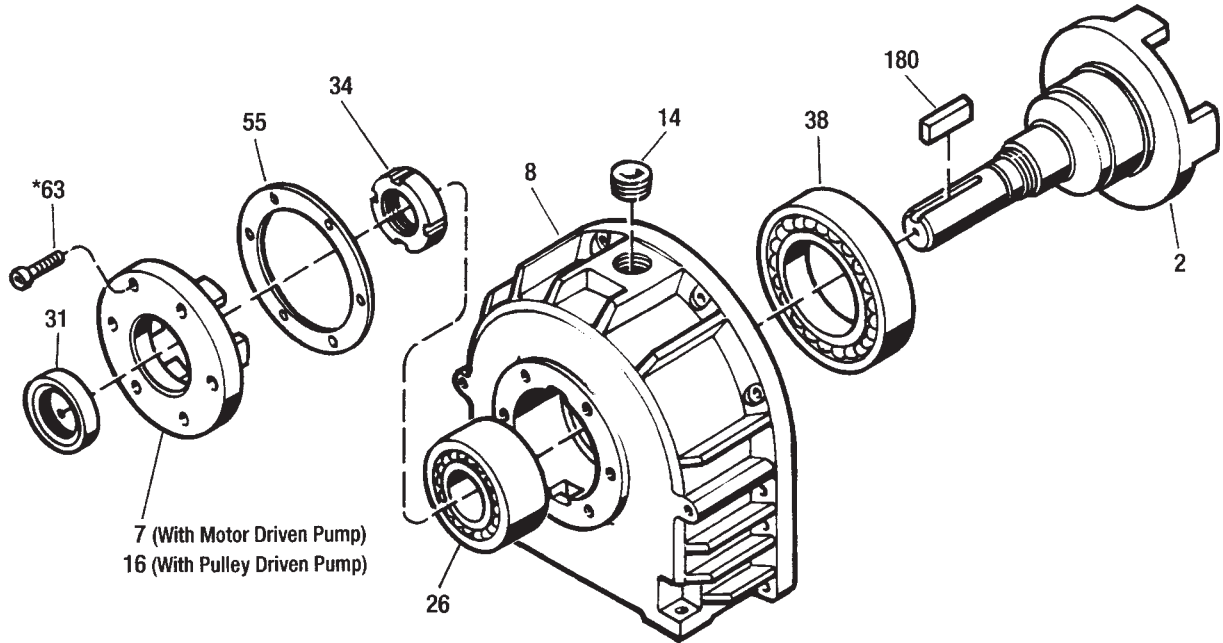

Figure 10.2 - Output C-Face Adapter (8-1/2" AK)

INPUT HOUSING SUB-ASSEMBLY (With Male Input Shaft for Coupling or Belt Drive)



* TORQUE SCREW (#63) to 9 Ft. Lbs.

(With Quill Input Shaft for C-Face Mounting)

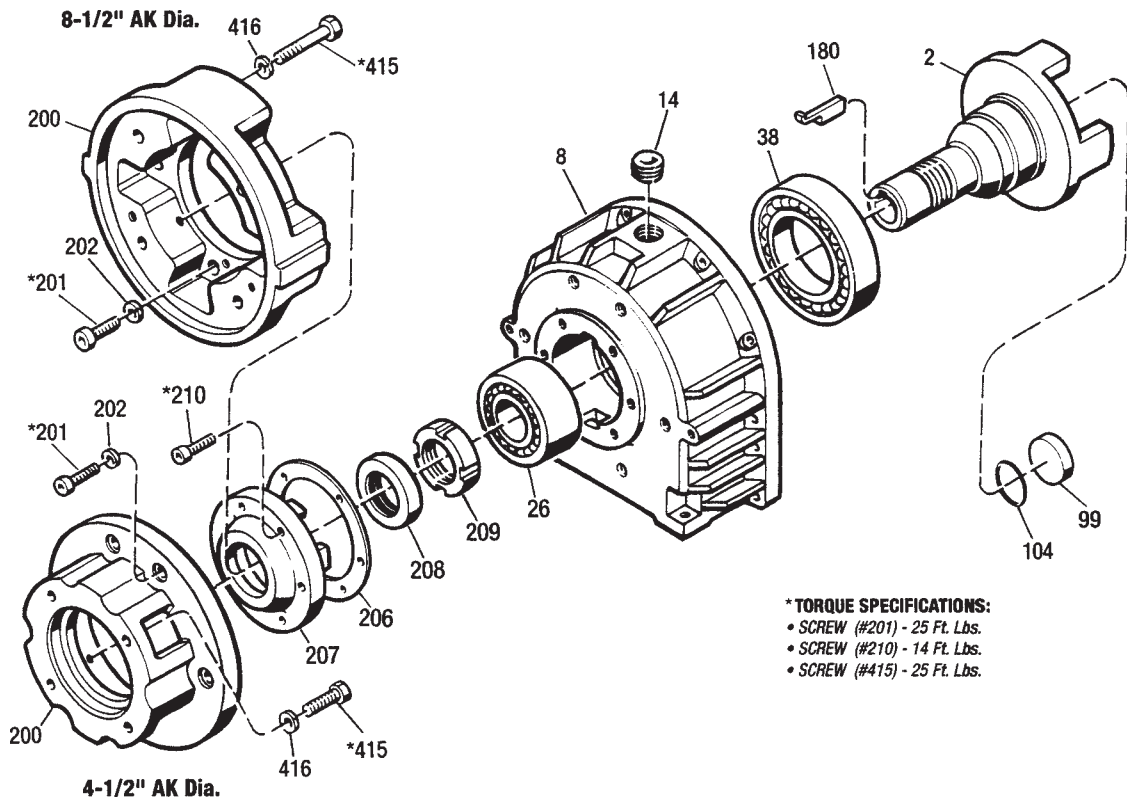

Figure 10.3 - Input Housing Sub-Assembly

Repair Parts List - (Figure 10.4)
FAN COOLING and WATER COOLING OPTIONS

REF. No.	PART NAME	QTY.	REF. No.	PART NAME	QTY.
24	Fan Shroud	1	176	Zinc Anode	1
25	Fan	1	177	Pipe Coupling	1
48	Heat Exchanger	1	178	Pipe Nipple	1
56	Soc. Hd. Cap Screw	2	180	Key	1
66	Soc. Hd. Cap Screw	2	185	Access Cover	2
70	Set Screw	2	237	Anti-Rotational Tag	2
71	Compression Fitting	2	242	Pipe Tee	1
152	But. Hd. Cap Screw	4			

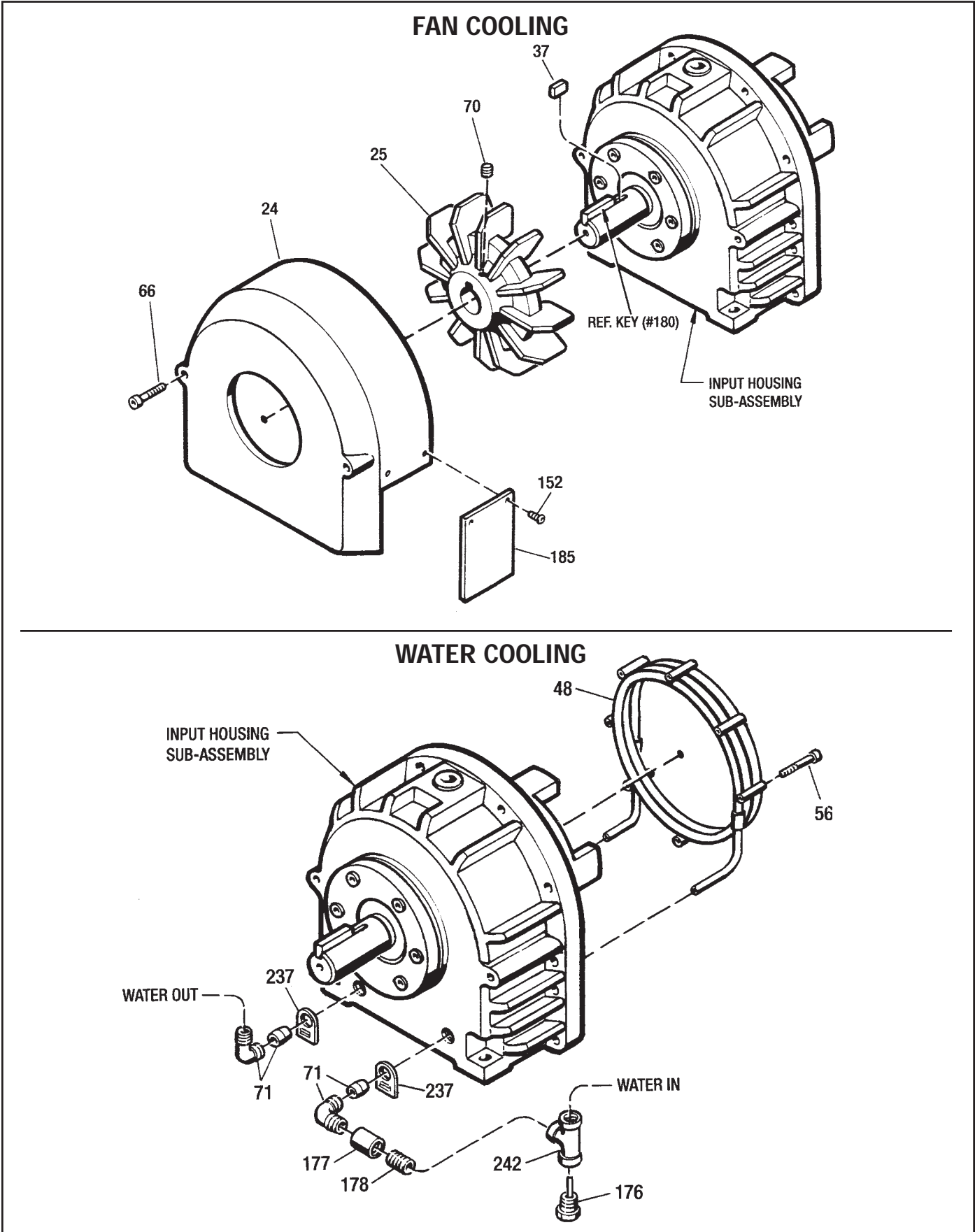

Figure 10.4 - Fan Cooling and Water Cooling Options

Repair Parts List - (Figure 10.5)
OPTIONAL POSITIONING ENCODER ASSEMBLY
HYDRAULIC CONTROL VALVES

REF. No.	PART NAME	QTY.	REF. No.	PART NAME	QTY.
17	Positioning Encoder Housing	1	241	Set Screw	1
22	Magnetic Pickup	1	253	Housing Cover	1
76	Soc. Hd. Cap Screw	4	257	Lockwasher	4
*103	O-Ring	1	259	Cable, 5-Pin Straight	1
*104	O-Ring	4	268	But. Hd. Cap Screw	4
105	Manifold	1	327	Pressure Gauge	
131	Pipe Plug	1		A, B and C Logics	1
137	Pipe Plug			S, SA and P Logics	2
	A, B and C Logics	2	355	Quadrature Pickup	1
	S, SA and P Logics	1	358	Soc. Hd. Cap Screw	4
138	Pipe Nipple, 1/4"	1	359	Lockwasher	4
139	Pipe Tee, 1/4"	1	368	Receptacle, 5-Pin	1
140	Reducer Bushing, 1/4" x 1/8"	1	372	Top Cover	1
154	Set Screw	1	387	Control Valve	1
177	Street Elbow	1	388	Relief Valve	1
182	Lockwasher	4	397	Pressure Gauge	1
186	Pulse Gear	1	400	Pressure Regulator	
198	Soc. Hd. Cap Screw	4		A, B and C Logics	1
*214	Shim	AR		S, SA and P Logics	2
225	But. Hd. Cap Screw	4	409	Plug (A, B and C Logics)	1
226	Rd. Hd. Cap Screw	2	901	Cable Fitting, 3-Pin	1
*228	O-Ring (A, B and C Logics)	1	902	Cable, 3-Pin Straight	1
234	Key	1			

*- Indicates parts in Minor Overhaul Kit

AR- As Required

OPTIONAL POSITIONING ENCODER ASSEMBLY

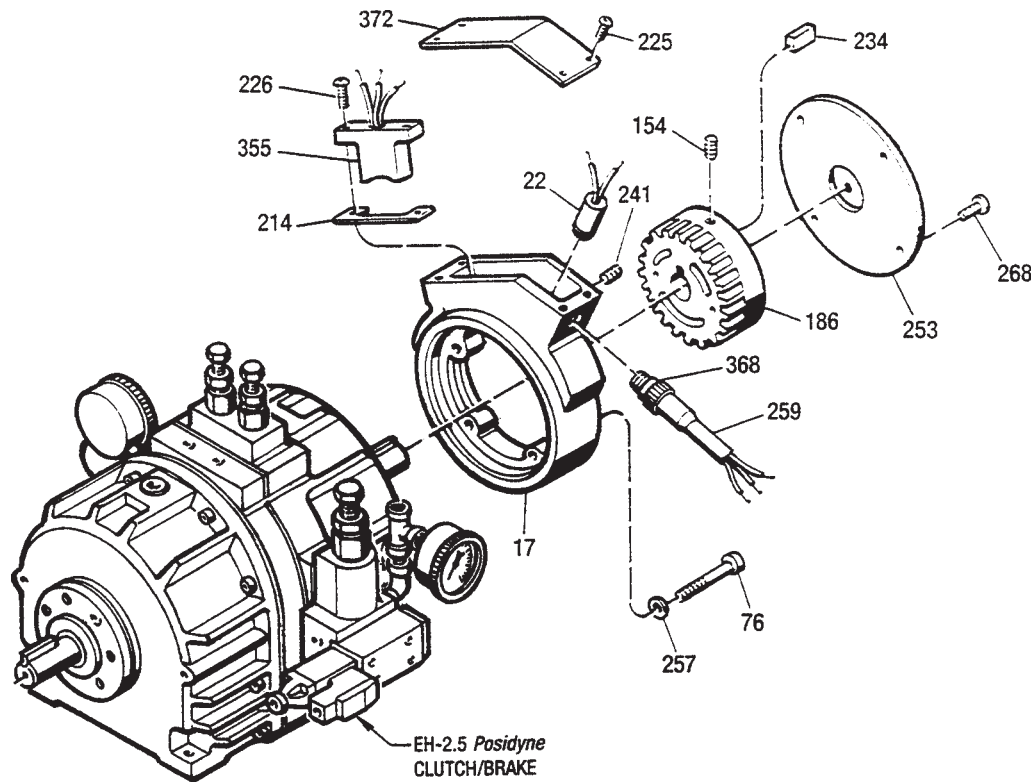

HYDRAULIC CONTROL VALVES

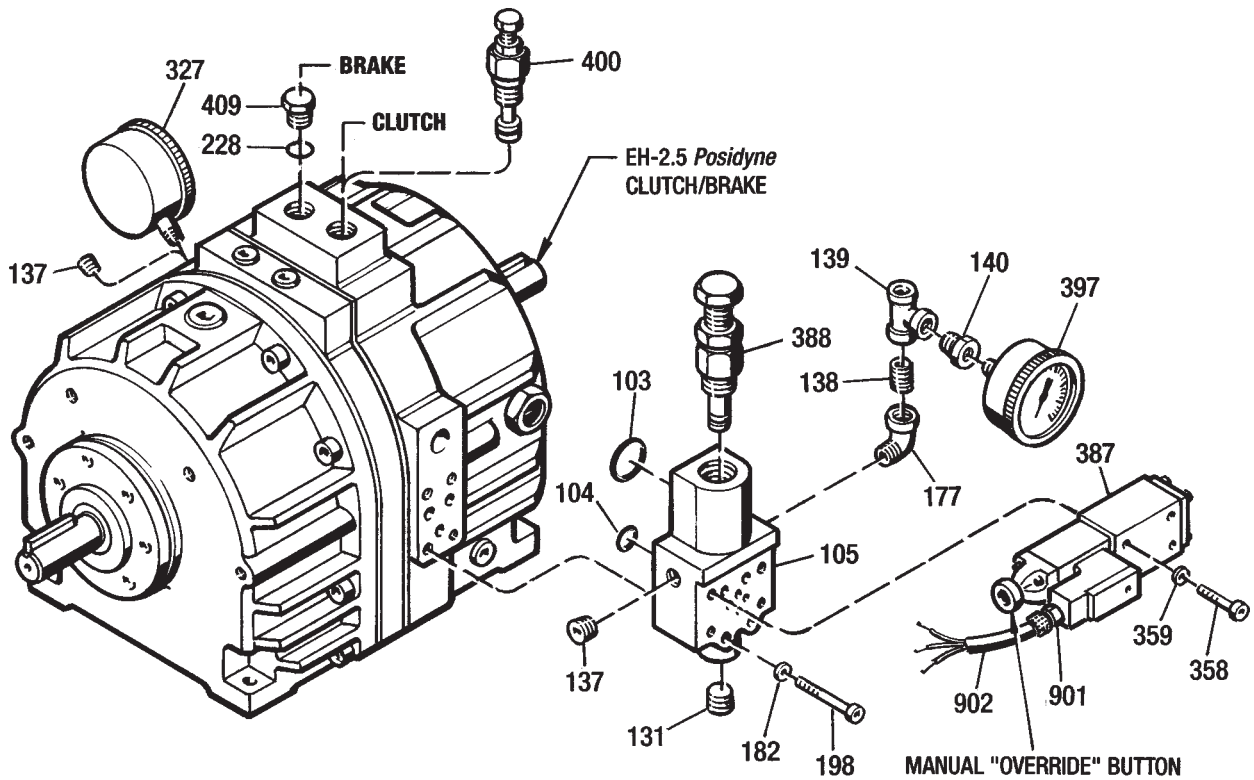

Figure 10.5 - Positioning Encoder Assembly; Hydraulic Control Valves

Repair Parts List - (Figure 10.6)
PIGGYBACK MOUNTING/MOTOR DRIVEN PUMP

REF. No.	PART NAME	QTY.	REF. No.	PART NAME	QTY.
76	Soc. Hd. Cap Screw	4	254	Stud	4
126	Pipe Nipple	1	255	Flat Hd. Cap Screw	4
142	90° Street Elbow	1	257	Lockwasher	8
147	Bracket, Motor Mounting, Input	1	262	Hex. Hd. Cap Screw	4
148	Bracket, Pump Mounting	1	264	Flat Washer	AR
149	Bracket, Motor Mounting, Output	1	305	Hex. Hd. Cap Screw	4
152	Hex Nut	8	357	Hex. Hd. Cap Screw	4
153	Motor Mounting Plate	1	360	Lockwasher	8
165	Filter Support Bracket	1	361	Lockwasher	4
166	Special Pipe Plug	1	370	Soc. Hd. Cap Screw	2
169	Hydraulic Hose	1	371	Lockwasher	3
170	Hydraulic Hose	1	373	Soc. Hd. Cap Screw	1
171	Hose Fitting	3	389	Hydraulic Pump	1
172	Hose Fitting	1	395	Hydraulic Filter	1
174	Swivel Fitting	2	396	Dirty Filter Indicator	1
177	90° Street Elbow	1	747	Coupling Hub, Motor	1
179	Reducer Bushing	2	748	Coupling Spider	1
222	Drive Motor	1	752	Coupling Hub, Pump	1

AR- As Required

PIGGYBACK MOUNTING/ MOTOR DRIVEN PUMP

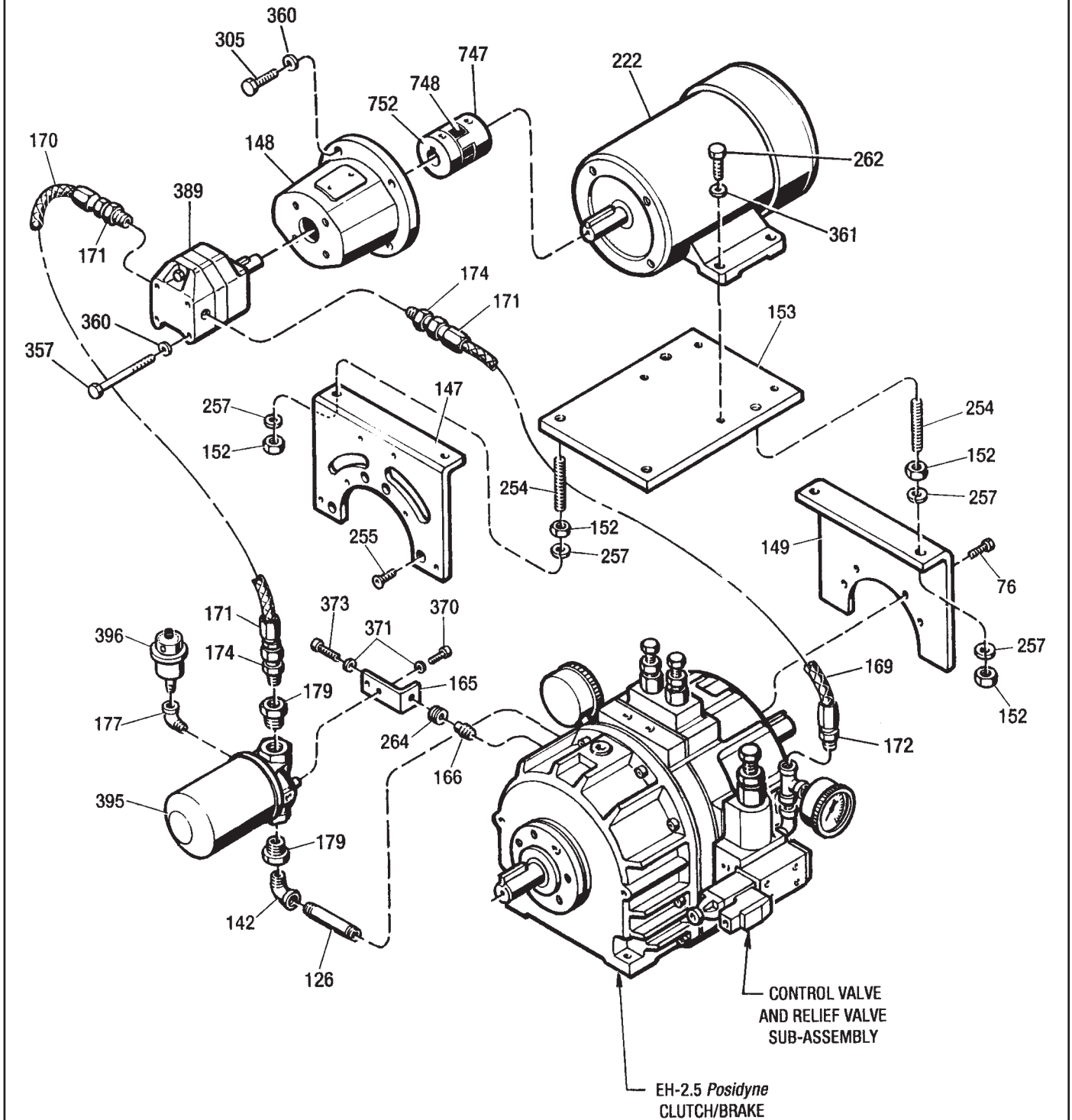

Figure 10.6 - Piggyback Mounting/ Motor Driven Pump

Repair Parts List - (Figure 10.7)
PIGGYBACK MOUNTING/PULLEY DRIVEN PUMP

REF. No.	PART NAME	QTY.	REF. No.	PART NAME	QTY.
124	Belt Guard	1	264	Flat Washer	AR
142	90° Street Elbow	1	265	Lockwasher	8
148	Pump Mounting Bracket	1	268	But. Hd. Cap screw	4
149	Belt Guard Bracket	4	288	Spacer	2
150	Soc. Hd. Cap Screw	6	305	Soc. Hd. Cap Screw	4
156	Pipe Nipple	1	330	Taper Bushing	1
165	Filter Mounting Bracket	1	331	Taper Bushing	1
166	Special Pipe Plug	1	332	Pulley, Pump	1
169	Hydraulic Hose	1	333	Pulley, Posidyne	1
170	Hydraulic Hose	1	334	Drive Belt	1
171	Hose Fitting	1	357	Hex. Hd. Cap Screw	2
172	Hose Fitting	2	360	Lockwasher	2
173	Hose Fitting	1	370	Soc. Hd. Cap Screw	2
174	Swivel Fitting	1	371	Lockwasher	3
175	Swivel Fitting	1	373	Soc. Hd. Cap Screw	1
177	90° Street Elbow	1	389	Hydraulic Pump	1
178	Reducer Bushing	3	395	Hydraulic Filter	1
179	Reducer Bushing	1	396	Dirty Filter Indicator	1

AR-As Required

PIGGYBACK MOUNTING/PULLEY DRIVEN PUMP

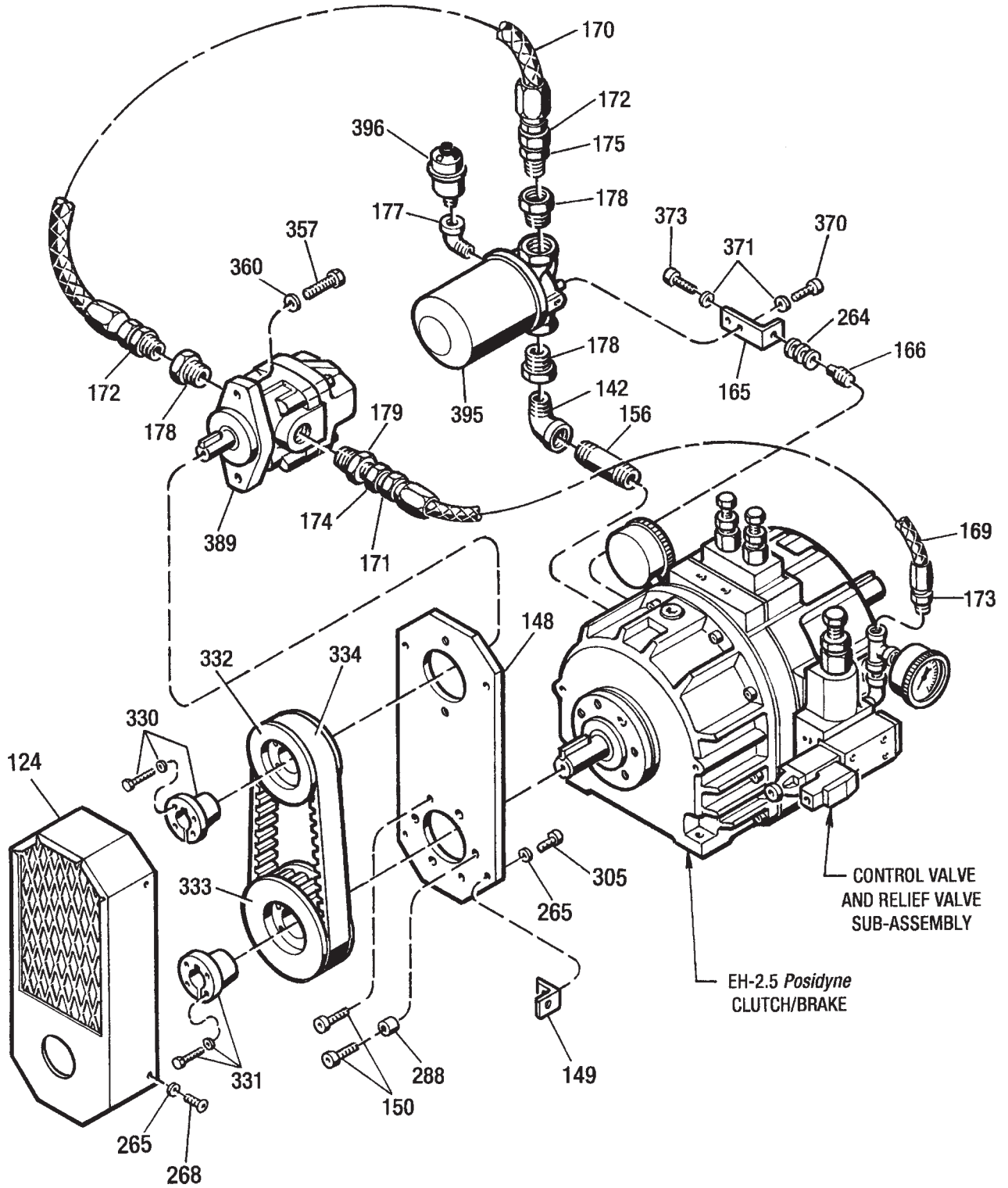

Figure 10.7 - Piggyback Mounting/Pulley Driven Pump

Repair Parts List - (Figure 10.8)
SIDE MOUNTING/MOTOR DRIVEN PUMP

REF. No.	PART NAME	QTY.	REF. No.	PART NAME	QTY.
126	Pipe Nipple	1	178	Reducer Bushing	1
142	90° Street Elbow	1	179	Reducer Bushing	2
143	45° Street Elbow	1	222	Drive Motor	1
148	Pump Mounting Bracket	1	305	Hex. Hd. Cap Screw	4
156	Pipe Nipple	1	357	Hex. Hd. Cap Screw	4
167	Pipe Tee	1	360	Lockwasher	8
169	Hydraulic Hose	1	389	Hydraulic Pump	1
170	Hydraulic Hose	1	395	Filter Assembly	1
171	Hose Fitting	3	396	Dirty Filter Indicator	1
172	Hose Fitting	1	747	Coupling Hub, Motor	1
174	Hose Swivel Adapter	2	748	Coupling Spider	1
177	90° Street Elbow	1	752	Coupling Hub, Pump	1

Manual Revision & Printing History

EH-2.5 Posidyne Clutch/Brake Drives

REVISION NUMBER	REVISION DATE (Mo./Yr.)	PRINTING DATE (Mo./Yr.)	REVISION/ACTION DESCRIPTION	REVISION INITIATED BY: (Name)	REVISION MADE BY: (Name)
502-EH-2.5-001	6/95	-----	New Manual	-----	-----
	-----	7/95	Printed	-----	-----
502-EH-2.5-001-01	12/03		Created complete digital file to create PDF file for the Web. New cover, added Warranty Information, removed Detroit address and added Revision History.	Jerry Brooks	Jerry Brooks

FORCE CONTROL INDUSTRIES, Inc.

*Providing today's industries
with Oil Shear Clutch and
Brake Drives that deliver ...*

- *Flexibility • Efficiency*
- *Endurance • Performance*
- and • *Dependability.*

" Built to Last - Guaranteed to Perform "



FORCE CONTROL INDUSTRIES, Inc.

MAIN OFFICE
P. O. Box 18366
Fairfield, Ohio 45018

3660 Dixie Highway
Fairfield, Ohio 45014

Tel: (513)868-0900
Fax: (513)868-2105



E-Mail: info@forcecontrol.com
Web: www.forcecontrol.com