



502-EL-02-003

# SERVICE MANUAL

AND

# REPAIR PARTS

FOR

## *EL-02 Posidyne Electro/Hydraulic Clutch/Brake Unit*

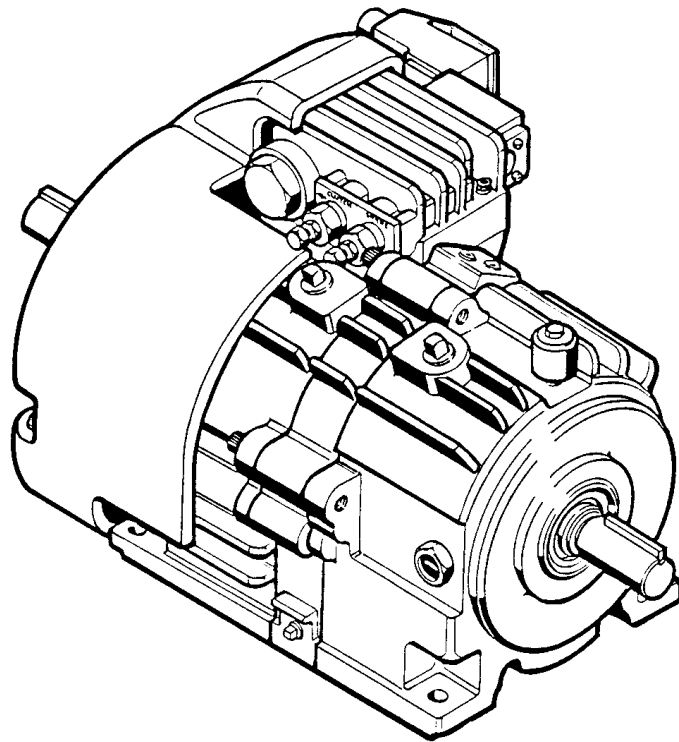

**WARNING - Read this manual before any installation, maintenance and operation.**



**FORCE CONTROL INDUSTRIES, INC.**

**MANUFACTURERS OF MECHANICAL AND  
ELECTRICAL POWER TRANSMISSION EQUIPMENT**



MEX (55) 53 63 23 31 MTY (81) 83 54 10 18  
QRO (442) 1 95 72 60 [ventas@industrialmagza.com](mailto:ventas@industrialmagza.com)

---

---

## LIMITED WARRANTY

### SPECIAL 24 MONTH WARRANTY

**Upon written approval of the application by Force Control Industries, Inc. the Standard Warranty period will be extended to 24 months.**

Force Control Industries, Inc. ("Force Control") warrants its products to be free from defects in material and workmanship under normal and proper use for a period of one year from the date of shipment. Any products purchased from Force Control that upon inspection at Force Control's factory prove to be defective as a result of normal use during the one year period will be repaired or replaced (at Force Controls' option) without any charge for parts or labor. This limited warranty shall be void in regard to (1) any product or part thereof which has been altered or repaired by a buyer without Force Control's previous written consent or (2) any product or part thereof that has been subjected to unusual electrical, physical or mechanical stress, or upon which the original identification marks have been removed or altered. Transportation charges for shipping any product or part thereof that the buyer claims is covered by this limited warranty shall be paid by the buyer. If Force Control determines that any product or part thereof should be repaired or replaced under the terms of this limited warranty it will pay for shipping the repaired or replaced product or part thereof back to the buyer. EXCEPT FOR THE EXPRESS WARRANTY SET OUT ABOVE, FORCE CONTROL DOES NOT GRANT ANY WARRANTIES EITHER EXPRESSED OR IMPLIED, INCLUDING IMPLIED WARRANTIES OF MERCHANTABILITY OR FITNESS FOR USE. The warranty obligation set forth above is in lieu of all obligations or liabilities of Force Control for any damages. Force Control specifically shall not be liable for any costs incurred by the buyer in disconnecting or re-installing any product or part thereof repaired or replace under the limited warranty set out above. FORCE CONTROL EXPRESSLY EXCLUDES ALL LIABILITY FOR ANY INDIRECT OR CONSEQUENTIAL DAMAGES THE BUYER MAY SUSTAIN IN CONNECTION WITH THE DELIVERY, USE, OR PERFORMANCE OF FORCE CONTROL PRODUCTS. Under no circumstances shall any liability for which Force Control is held responsible exceed the selling price to the buyer of the Force Control products that are proven to be defective. This limited warranty may be modified only in writing signed by a duly authorized officer of the company. This limited warranty applies exclusively to Force Control products; warranties for motors and gear reducers and other component parts may be provided by their respective manufactures. Any legal action for breach of any Force Control warranty must be commenced within one year of the date on which the breach is or should have been discovered.

A Return Goods Authorization (RGA) number must be obtained from the factory and clearly marked on the outside of the package before any equipment will be accepted for warranty work. Force Control will pay the shipping costs of returning the owner parts that are covered by warranty.

Force Control believes that the information in this document is accurate. The document has been carefully reviewed for technical accuracy. In the event that technical or typographical errors exist, Force Control reserves the right to make changes to subsequent editions of this document without prior notice to holders of this edition. The reader should consult Force Control if errors are suspected. In no event shall Force Control be liable for any damages arising out of or related to this document or the information contained in it.

**FORCE CONTROL INDUSTRIES, INC.**



MEX (55) 53 63 23 31 MTY (81) 83 54 10 18  
QRO (442) 1 95 72 60 [ventas@industrialmagza.com](mailto:ventas@industrialmagza.com)



# TABLE OF CONTENTS

## Section 1 - DESCRIPTION AND OPERATION

1-1 UNIT DESCRIPTION .....	1
1-2 OIL SHEAR PRINCIPLE .....	2
1-3 OPERATION .....	2

## Section 2 - SPECIFICATIONS

Table 1- SPECIFICATIONS .....	4
-------------------------------	---

## Section 3 - INSTALLATION

3-1 IMPORTANT SAFETY PRECAUTIONS .....	5
3-2 RECEIVING THE DRIVE .....	5
3-3 MOUNTING THE DRIVE .....	5
3-4 ELECTRICAL WIRING .....	6
3-4-1 Drive Motor .....	6
3-4-2 Solenoid Control Valve .....	6
3-5 RECHECKING INSTALLATION .....	6

## Section 4 - LUBRICATION

4-1 CHECKING THE OIL LEVEL .....	7
4-2 CHANGING THE OIL .....	7
4-3 TYPE OF OIL .....	7

## Section 5 - OPERATIONAL CHECKS

5-1 SET-UP FOR CHECKING PISTON SEAL LEAKAGE AND PISTON MOVEMENT .....	8
5-2 CHECKING PISTON SEAL LEAKAGE AND PISTON MOVEMENT .....	9
5-3 INITIAL SET-UP FOR CHECKING HYDRAULIC OPERATION .....	10
5-4 HYDRAULIC OPERATIONS CHECK .....	10
5-5 CHECKING THE SOLENOID CONTROL VALVE AND DRIVE MOTOR OPERATION .....	11

## Section 6 - TROUBLESHOOTING

6-1 TROUBLESHOOTING CHART .....	12
6-2 REMEDIES .....	13

## Section 7 - DISASSEMBLY

7-1 PRELIMINARY DISASSEMBLY PROCEDURE .....	14
7-2 SEPARATION OF MAIN SUB-ASSEMBLIES FOR ACCESS TO THE CLUTCH/BRAKE STACKS .....	14
7-2-1 General Information .....	14
7-2-2 Removing The Fan Shroud .....	14
7-2-3 Access To The Clutch Stack .....	14
7-2-4 Access To The Brake Stack .....	15

### **DISASSEMBLY OF MAIN SUB-ASSEMBLIES**

7-3 INPUT HOUSING SUB-ASSEMBLY .....	15
7-3-1 Removal & Disassembly Of The Manifold & Control Valve .....	15
7-3-2 Removing Cooling Fan From Input Shaft .....	15
7-3-3 Removal & Cleaning Of The Suction Strainer (#912) .....	15
7-3-4 Removal & Disassembly Of The Pump Assembly .....	16
7-3-5 Removing The Input Shaft From The Input Housing .....	16
7-3-6 Input Shaft Disassembly .....	17
7-4 PISTON HOUSING SUB-ASSEMBLY .....	17

7-4-1 Removal Of Piston Liners & O-Rings .....	17
7-4-2 Disassembly Of The Piston Sub-Assembly .....	17
7-5 OUTPUT HOUSING SUB-ASSEMBLY .....	18
7-5-1 Removing Output Shaft Sub-Assembly .....	18
7-5-2 Output Shaft Disassembly .....	18

## Section 8 CLEANING AND INSPECTION

8-1 CLEANING .....	19
8-2 INSPECTION .....	19
8-3 REPAIR AND REPLACEMENT .....	19

## Section 9 - REASSEMBLY

9-1 GENERAL REASSEMBLY INSTRUCTIONS .....	20
---	----

### **REASSEMBLY OF MAIN SUB-ASSEMBLIES**

9-2 OUTPUT HOUSING REASSEMBLY .....	20
9-2-1 Output Shaft Reassembly .....	20
9-2-2 Output Housing Sub-Assembly .....	20
9-3 PISTON HOUSING REASSEMBLY .....	21
9-3-1 Piston Sub-Assembly .....	21
9-3-2 Installing The Piston Sub-Assembly Into The Piston Housing .....	21
9-4 INPUT HOUSING REASSEMBLY .....	21
9-4-1 Input Shaft Sub-Assembly .....	21
9-4-2 Installing The Assembled Input Shaft Into The Input Housing .....	22
9-4-3 Hydraulic Pump Reassembly .....	22
9-4-4 Reassembly Of The Pump Housing, Suction Strainer & Cooling Fan .....	23
9-4-5 Input Manifold Reassembly .....	23
A. Relief Valve Cartridges .....	23
B. Filter Replacement .....	24
C. Control Valve Mounting .....	24
D. Mounting The Manifold Assembly To The Input Housing .....	24
9-5 MAIN SUB-ASSEMBLIES AND CLUTCH/BRAKE STACK INSTALLATION .....	24
9-6 FINAL REASSEMBLY .....	24

## Section 10 - ORDERING REPAIR PARTS

10-1 GENERAL INFORMATION .....	25
10-2 FACTORY REBUILD SERVICE .....	25
A. Shipping Address .....	25
B. Telephone & Fax Number .....	25
C. E-Mail & Web Site .....	25
10-3 MINOR AND MAJOR OVERHAUL KITS .....	25
10-4 DRIVE MOTORS .....	25
10-5 NAME PLATE .....	25
10-6 ORDERING REPAIR PARTS .....	25

Figure 10.01 - SUB-ASSEMBLIES AND CLUTCH/ BRAKE STACKS .....	27
Figure 10.02 - INPUT HOUSING SUB-ASSEMBLY .....	29
Figure 10.03 - PISTON HOUSING SUB-ASSEMBLY .....	31
Figure 10.04 - OUTPUT HOUSING SUB-ASSEMBLY .....	31

**FORCE CONTROL INDUSTRIES, INC.**



MEX (55) 53 63 23 31 MTY (81) 83 54 10 18  
QRO (442) 1 95 72 60 ventas@industrialmagza.com



# Section 1 - DESCRIPTION & OPERATION

## 1-1 UNIT DESCRIPTION

The EL-02 *Posidyne* is an electrical operated Clutch/ Brake Unit which is self-contained and eliminates the need for external pneumatic or hydraulic piping. The only required external power source is 120.VAC, 60 Hz shop electric. A positive displacement hydraulic pump is utilized to generate the clamping force to engage the Clutch/Brake Stacks.

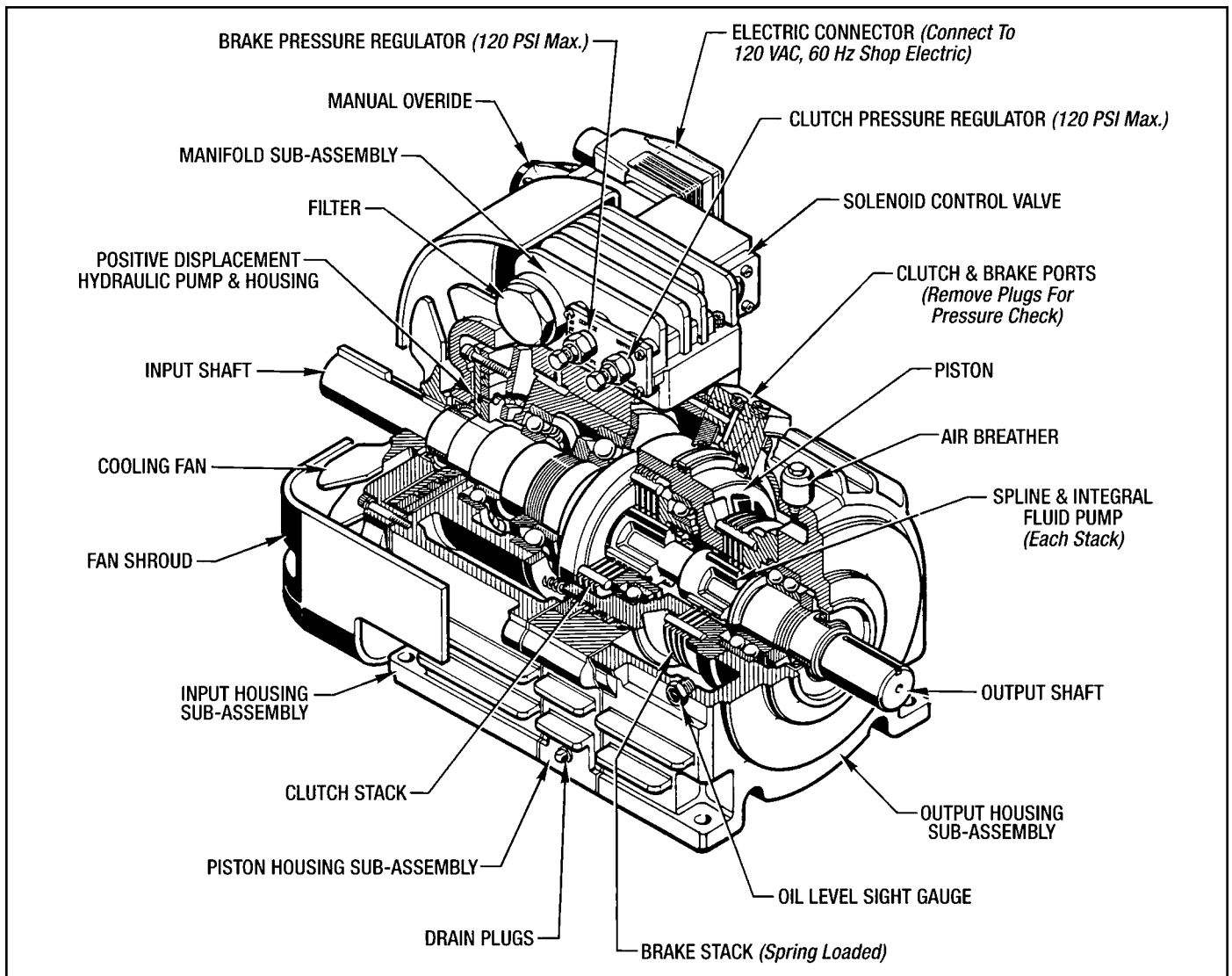

Figure 1.1 - EL-02 Posidyne Clutch/Brake Description

## EL-02 ELECTRIC *Posidyne* MAIN SUB-ASSEMBLIES AND COMPONENTS

### 1. The Input Housing Sub-Assembly

- Male Input Shaft for direct coupling or belt drive to the input drive motor.
- Cooling Fan.
- Pump Housing and a Hydraulic Pump which generates the hydraulic clamping force for the Clutch/Brake Stacks. The pump elements are driven by the input shaft.
- Suction Strainer.

### 2. The Manifold and Control Valve Sub-Assembly

- Filter.
- Adjustable Pressure Regulators to regulate the necessary Clutch/Brake clamping force as determined by the torque requirements established in Section 2 - SPECIFICATIONS.
- Four-way Solenoid Control Valve - Clutch or Brake selection. (De-energized-BRAKE), (Energized-CLUTCH)

### 3. The Piston Housing Sub-Assembly

- Clutch/Brake Piston and Seals.
- Piston Housing and Retainer.

### 4. The Output Housing Sub-Assembly -

- Male output shaft with splined integral impeller sections to maintain the **"Oil Shear Principle."**
- Air breather and sight gauge.

### 5. The Clutch and Brake Stacks -

In the EL-02 *Posidyne* clutch and brake stacks, the friction surfaces consist of alternate carbon steel drive plates and friction discs. The friction discs consist of a resilient paper based friction material bonded to steel discs with oil control grooves machined into the friction surfaces. (See Figure 1.02) The friction discs have internal teeth which mate with a spline on the output shaft. The drive plates are keyed to the input shaft for the clutch and to the output housing for the brake. The splined sections of the output shaft contains four oil inlet cavities that act as an impeller to force a positive flow of oil between the friction discs and the drive plates maintaining the **"Oil Shear Principle"** described in Section 1-2.

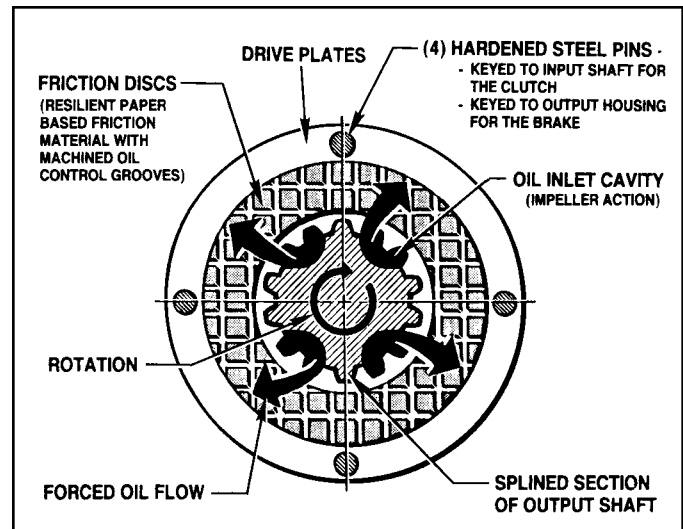

Figure 1.02 - The "Oil Shear" Principle

## 1-2 OIL SHEAR PRINCIPLE

Conventional clutches and brakes depend on the friction between solid surfaces operating in air to transmit torque. Friction does the job, but produces a great amount of heat and wear. The *Posidyne* Clutch/Brake units are oil shear drives, with the friction surfaces operating in a bath of oil. The oil molecules tend to cling to each other and to the friction surfaces. As moving and stationary elements are brought together, a thin but positive film of oil is maintained between them, controlled by the clamping pressure and carefully designed grooves in the elements. Torque is transmitted from one element to the other through the viscous shear of the oil film. So long as there is relative motion between the elements, they are protected by the oil, thus greatly reducing wear. The oil bath also effectively transmits heat away from the friction elements.

## 1-3 OPERATION

(See Figure 1.03)

The Hydraulic Pump, keyed to the input shaft, is driven at a constant motor speed, producing a positive high pressure flow of 2 gallons per minute. The pressurized oil is pumped to the manifold section through a highly efficient sintered-bronze filter into the 4-way Sol. Control Valve, which determines Clutch or Brake selection.

When the control valve is de-energized the oil is directed to the L.H. side of the piston forcing the piston to the right, clamping the Brake Stack. The Brake is normally springloaded so the hydraulic brake clamping force is only a "brake assist" to insure a fast and reliable braking operation.

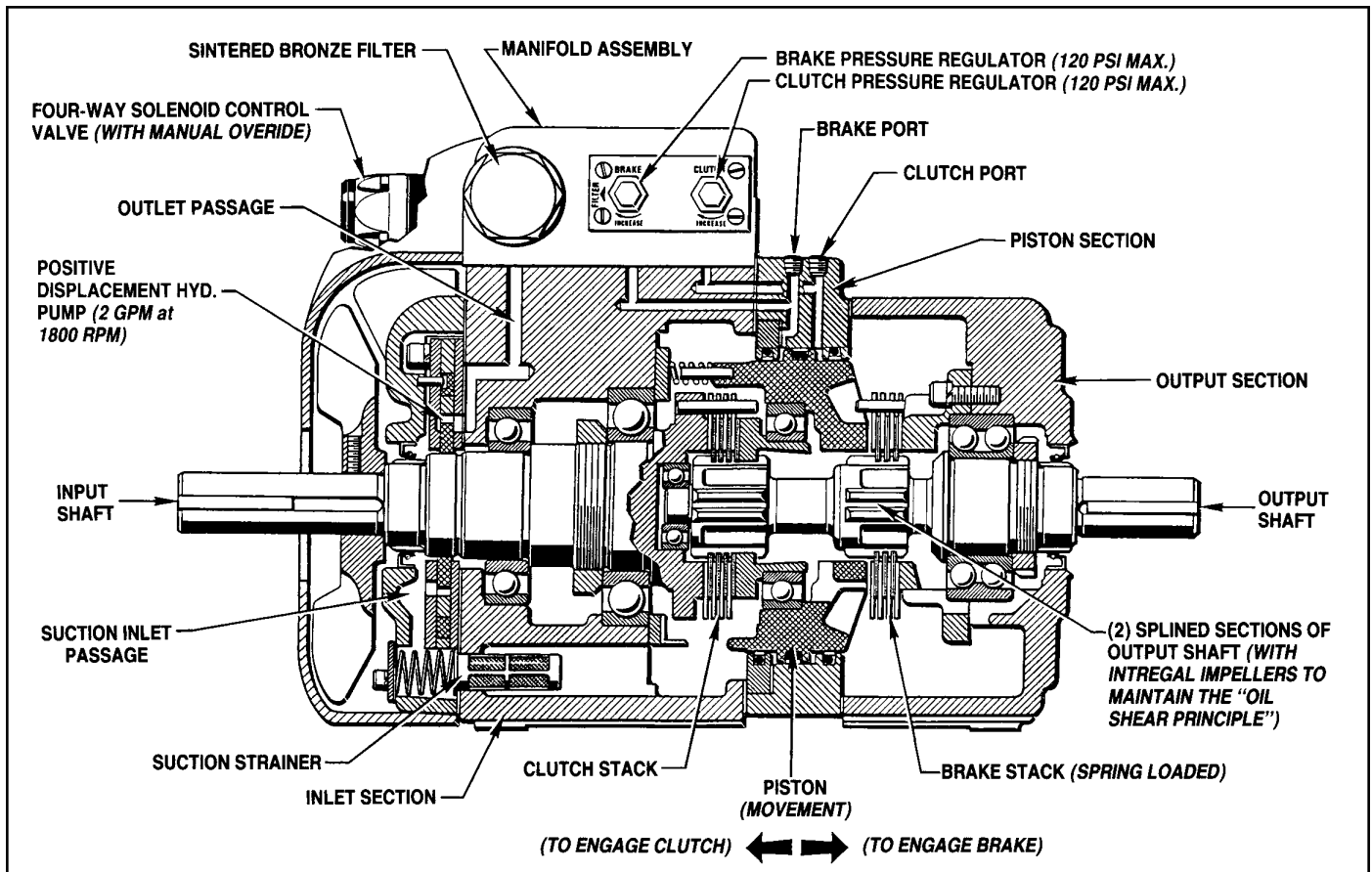

Figure 1.03 - EL-02 Posidyne Clutch/Brake Operation

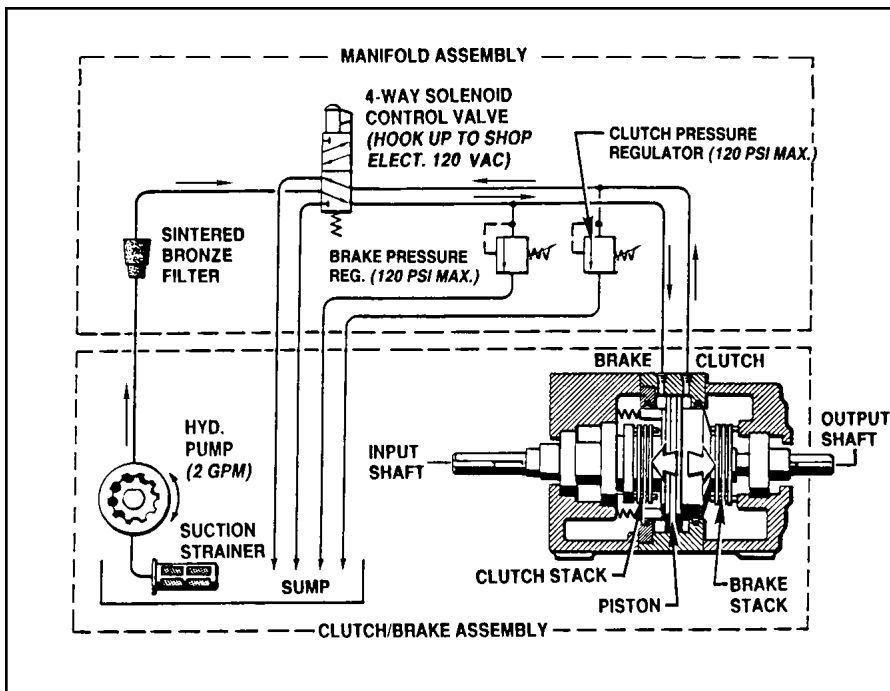

Figure 1.04 - Hydraulic Diagram (Operation)

Energizing the control valve directs the oil to the R.H. side of the piston, forcing it to the left clamping the Clutch Stack. Driving torque is then transmitted from the input shaft, utilizing the **"Oil Shear Principle"**, to the output shaft.

Adjustable pressure regulators in the manifold determines the delivered clamping force to the piston for the necessary driving and braking torque requirements.

The EL-02 Posidyne Clutch/Brake Unit provides the major advantage of being installed and used in applications where there is no source of external pressurized shop air or hydraulic fluid.

# Section 2 - SPECIFICATIONS

## 2-1 GENERAL SPECIFICATIONS

Size	Logic	Maximum Clutch Torque			Maximum Brake Torque					Input RPM		Max. KE per Engmt.	Avg. Thermal HP Fan	Inertia of Cyclic Parts (Lbs. Ft. <sup>2</sup> )	Weight (Lbs.)	Fluid (Qts.)
		Static	Dynamic	Max. Hyd. Pr.	Springs Only		With Max. Air Assist			Max.	Min.					
					Static	Dyn.	Static	Dyn.	Max. Hyd. Pr.							
02	S	445	383	60 psi	40	34	472	406	60 psi	1800	900	11,230	Horiz. 1.5	.03	94	3
	SA	368	316	80 psi	105	90	332	286	40 psi							
	A	387	333	80 psi	110	95	----	----	----							
	B	240	206	80 psi	220	189	----	----	----							
	C	254	218	60 psi	----	----	----	----	----							

**NOTES:**

1. All ratings established @ 1800 RPM maximum input speed..
2. Control Valve Electrical Requirements = 120/220 VAC, 60 Hz..
  - a. Holding Current = 46 VA.
  - b. Inrush Current = 130 VA.
  - c. Switching Time: On = 30 msec, Off = 20 msec.
  - d. Other control voltages are available. Consult Force Control with requirements.

## 2-2 TECHNICAL SPECIFICATIONS

Size	Logic	CLUTCH				BRAKE						
		Max. Static Torque (Lb. In.)	Max. Actuation Pressure (psi)	C <sub>E</sub> Engmt. Pressure (psi)	C <sub>T</sub> Net Static Torque (Lb. In./psi)	Spring Set Static Torque (Pump Off) (Lb. In.)	Min. Static Torque (Pump On) (Lb. In.)	Min. Pressure (Pump On) (psi)	Max. Static Torque (Lb. In.)	Max. Actuation Pressure (psi)	B <sub>S</sub> Spring Bias Pressure (psi)	B <sub>T</sub> Net Static Torque (Lb. In./psi)
02	S	445	117	5	4	13	97	25	419	120	4	3.4
	SA	343	120	33	4	94	178	25	332	70	28	3.4
	A	305	120	43	4	133	133	25	----	----	39	----
	B	134	120	86	4	265	265	25	----	----	78	----
	C	253	107	43	4	----	----	----	----	----	----	----

**NOTES:**

1. Multiply the above Static Torque Ratings by .86 to get the Dynamic Torque Ratings.
2. Reaction time is the time the hydraulic valve is energized or de-energized and until there is a change in output shaft rotation. (Rexroth valve with 115 VAC coil).

To find Torque Developed at a given Actuation Pressure.

To find Actuation Pressure needed for Req'd. Torque.

$$\text{Clutch Torque} = (\text{PSI} - C_E) \times C_T$$

$$\text{Brake Torque} = (\text{PSI} + B_S) \times B_T$$

PSI = Actuation Pressure

$$\text{Clutch PSI} = (T_R / C_T) + C_E$$

$$\text{Brake PSI} = (T_R / B_T) - B_S$$

T<sub>R</sub> = Static Torque Required

---

---

## Section 3 - INSTALLATION

### 3-1 IMPORTANT SAFETY PRECAUTIONS

The EL-02 Electric *Posidyne* described in this manual must not be installed or operated at any speeds, horsepower loads or temperatures not specified in this manual.

Failure to limit operating conditions of the drive to all specified conditions could damage the Drive Unit and cause damage to interconnected equipment.

**WARNING:**

**Before any installation and attempting any repairs to the drive, open the electrical disconnects to the Input Drive Motor and the Solenoid Control Valve. Lock them out to avoid any possibility of personal injury.**

### 3-2 RECEIVING THE DRIVE

Check the drive for shortage or damage immediately after arrival. Prompt reporting to the carrier's agent, with notations made on the freight bill, will expedite satisfactory adjustment by the carrier. When unloading or handling the drive, keep it upright. All drives are filled with oil, ready to run, when shipped. However, before placing the unit in service or storage, check the oil level to make sure none has spilled out in transit. Add oil if necessary. (Refer to **Section 4, LUBRICATION.**)

If the drive is not to be installed and operated soon after arrival, store it in a clean, dry place with a slow, moderate change in ambient temperature. Actuate the pistons and rotate the shafts once a month to relubricate the working surfaces.

### 3-3 MOUNTING THE DRIVE

Installation of the drive should be made in the same manner and receive the same care as for a precision gear reducer. Standard drives are designed for horizontal operation. Vertical mounting and operation is available as an option. Consult the Force Control factory for vertical mounting instructions.

#### NOTE THE FOLLOWING PRECAUTIONS WHEN MOUNTING THE DRIVE:

1. The drive should be mounted on a firm, level base or foundation.

Use Socket Head Cap Screws or SAE grade 5 Bolts to bolt the drive securely in place. Before tightening down the bolts, check alignment with driven machinery. Recheck alignment after tightening.

2. If the Input Motor Drive Shaft is to be directly coupled, only use a flexible coupling, with a horsepower service factor of 3 to 1, for maximum torque requirements. Make sure that the shafts to be coupled are concentric within the coupling manufacturers' specifications. Check for horizontal, vertical and angular misalignment. Use shims as necessary to correct any misalignment.

**CAUTION:**

**Do not drive couplings or bushings onto the shafts, as this may damage the internal bearings.**

3. If the Input Motor Drive Shaft is to be connected with a belt, chain or gear drive, locate the sheave, sprocket or gear as close as possible to the drive housing and the drive motor bearing to minimize overhung loads. Align to run true and adjust belt or chain tension per manufacturers' specifications.

**CAUTION:**

**Excessive belt or chain tension will damage the bearings.**

4. Furnish and install appropriate safety guards for all external rotating parts.
5. The Air Breather (#45) is removed before shipment and a pipe plug put in its place. In most cases this will be a red plastic plug. This is to prevent oil spillage during shipment. This plug must be removed and the Breather (#45) installed to prevent damage to the drive. The Breather is taped to the drive for shipment.

**CAUTION:**

Failure to install this Breather (#45) will result in overheating, which will cause the clutch and brake components to malfunction and void the warranty.

### 3-4 ELECTRICAL WIRING

#### 3-4-1 Drive Motor

(See Motor Plate for Electrical Diagram.)

#### 3-4-2 Solenoid Control Valve

Install electrical wiring as shown in Electrical Wiring Diagram (Figure 3.01) to shop electric.

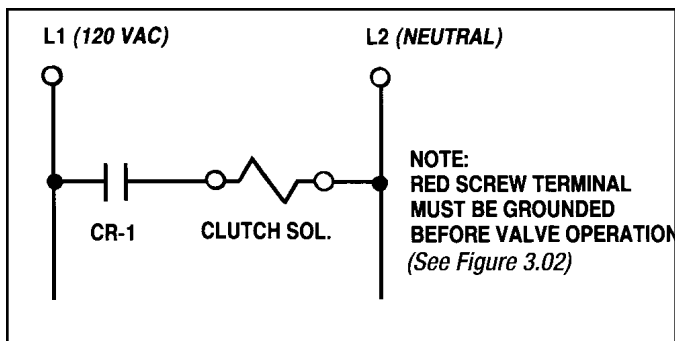

Figure 3.01 - Electrical Wiring Diagram

The Plug-In Elect. Connector can be rotated in 90° increments. Position as desired (See Figure 3.02)

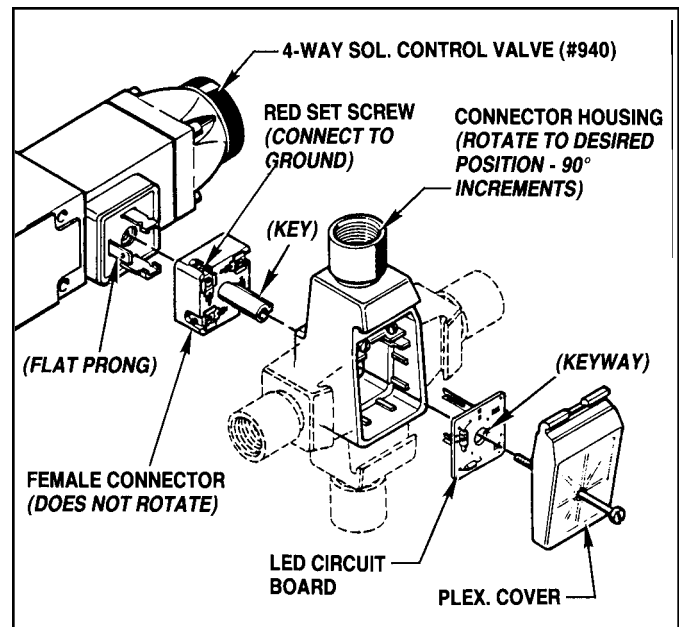

Figure 3.02 - Electrical Connector

### 3-5 RECHECKING INSTALLATION

1. After the drive has been in operation for a few hours, make sure that all mounting bolts are tight and secure. Also recheck alignment of all driving components.
2. After 40 hrs. of operation check mounting bolts and tighten if necessary.

---

---

## Section 4 - LUBRICATION

### 4-1 CHECKING THE OIL LEVEL

When the drive is installed and weekly thereafter, or until experience dictates otherwise, check the oil level. Always check the oil level with the drive at room temperature and while it is not running.

The drive has an oil sight gauge located at the output end of the drive. The oil level is to show at the center of the gauge.

### 4-2 CHANGING THE OIL

**CAUTION:**  
Open the disconnects to the drive motors before attempting to change the oil.

Every three months completely drain the oil from the drive using the drain plugs provided. If the oil sight gauge is dirty it should be removed and cleaned.

Reinstall the drain plugs and refill the drive to the center of the sight gauge with fresh oil.

**CAUTION**  
Do not overfill the Drive Unit. Excess oil will cause the unit to overheat.

### 4-3 TYPE OF OIL

Use only Mobil Automatic Transmission Fluid ATF210 (type F) or Mobil Multi-purpose Automatic Transmission Fluid. Other fluids may be specified for special applications. Always use the type of fluid specified on the Name Plate.

**IMPORTANT**  
Use of unauthorized transmission fluid substitute will void the warranty.

# Section 5 - OPERATIONAL CHECKS

These Operational Checks are to be made when the drive unit is removed from service for repair.

## 5-1 SET-UP FOR CHECKING PISTON SEAL LEAKAGE AND PISTON MOVEMENT

Provisions must be made to supply 120 PSI max. air supply to the clutch and brake ports. If shop air is not available, a suitable air compressor or a pressurized air tank must be utilized.

Two special pneumatic fittings (#959) must be installed in the clutch and brake ports to make this operational check. These fittings are supplied by Force Control as an option or they may be machined in a local or your machine shop. The machining dimensions and part specifications are given in Figure 5.01.

**CAUTION**  
**Lock-out all electrical power to the drive motor before making this operational check.**

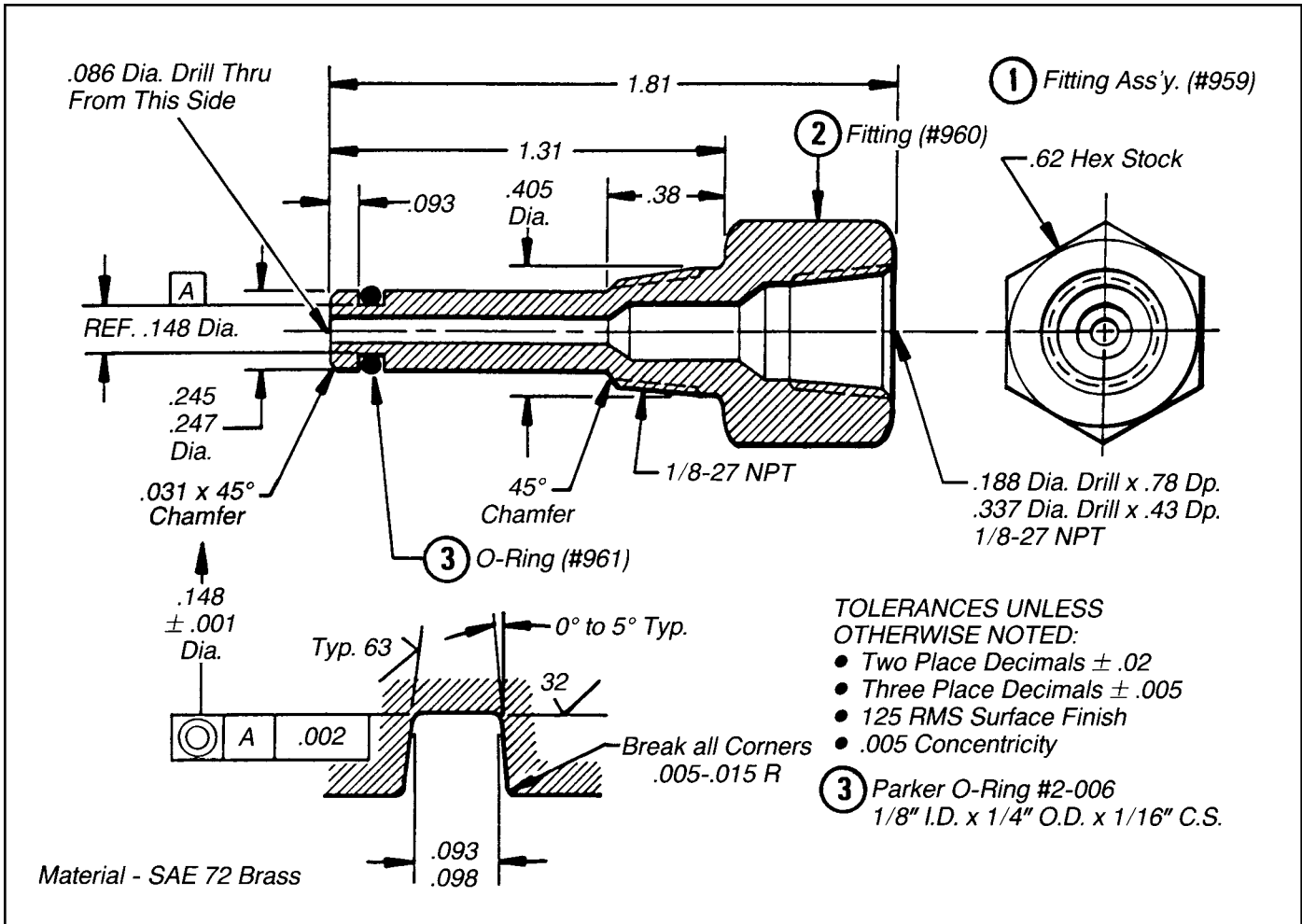

Figure 5.01 - Machining Dimensions For Special Pneumatic Operational Check Fitting

1. Remove the (2) 1/8" NPT Pipe Plugs (#74) from the Piston Housing. After lubricating the O-Ring (#961) install the two Special Air Connection Fittings (#959) into the Piston Housing.
2. Install the 120 PSI air supply to the unit as shown in Figure 5.02. (Example only)
3. Remove the two Inspection Plugs (#14) from the drive unit.

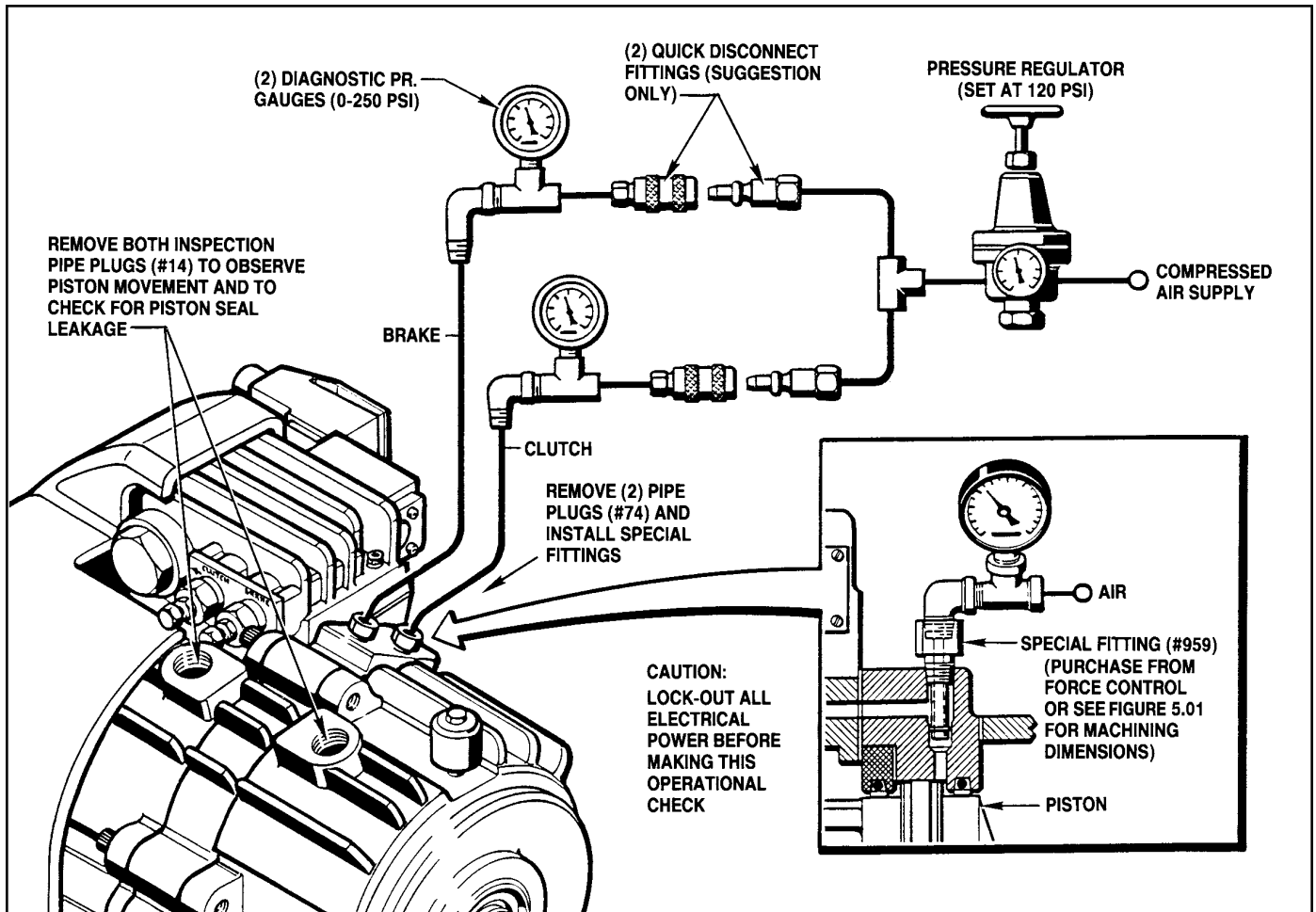

Figure 5.02 - Pneumatic Set-Up For Operations Check

## 5-2 CHECKING PISTON SEAL LEAKAGE AND PISTON MOVEMENT

1. Manually apply air pressure to the clutch port and with the aid of a flashlight observe the piston movement to see if it actuates quickly and smoothly. Internal damage may be indicated if the piston action is irregular and sticks or binds.

Also listen for air leaks and look for air bubbles in the oil that would indicate damaged piston seals.

2. Exhaust the air from the clutch port. The piston should move all the way to the right to engage the Brake Stack, since it is spring-loaded. Apply air to the brake port. Listen for air leaks and look for any air bubbles in the oil that would indicate piston seal leakage. Exhaust the air from the brake port.

**NOTE:**

Also when applying air to the clutch and brake ports, if the air pressure will not build up to the 120 PSI or suddenly drops (as indicated on the pressure gauges) this would indicate leakage across the piston seals.

3. Remove the special fittings and air lines from the piston housing. Replace the Inspection Plugs (#14) back into the drive unit.

**5-3 INITIAL SET-UP FOR CHECKING HYDRAULIC OPERATION** (See Figure 5.03)

Refer to **Section 3, INSTALLATION** for detailed mounting instructions and electrical wiring specifications and requirements.

1. Mount the Drive Unit and a 1 to 2 H.P., 1800 RPM Drive Motor with a flexible coupling to the work bench.
2. Hook-up the drive motor as per manufacturers' specs. and the wiring diagram on the motor name plate.
3. It is not necessary to hook-up the Solenoid Valve for this Operations Check. The Manual Override Button can be used to actuate the Clutch.

4. Install (2) diagnostic pressure gauges (0-250 PSI) in the clutch and brake ports as shown in *Figure 5.03*.

**IMPORTANT**  
Make sure that the (2) Inspection Plugs are reinstalled before starting up the unit.

**5-4 HYDRAULIC OPERATIONS CHECK**

1. Start up the drive motor and observe the pressure reading on the "Brake" pressure gauge. The normal reading should be a steady 120 PSIG.
2. Push the "Manual Override" Button on the solenoid control valve and observe the "Clutch" pressure gauge. Again the normal reading should be a steady 120 PSIG. The output shaft should also rotate when the clutch is engaged.
3. Release the "Manual Override" Button. Pressure will again be applied to the "Brake". The output shaft should stop rotating.

If both readings on the pressure gauges are abnormal and similar in nature, then damage could be indicated in the Hydraulic pump.

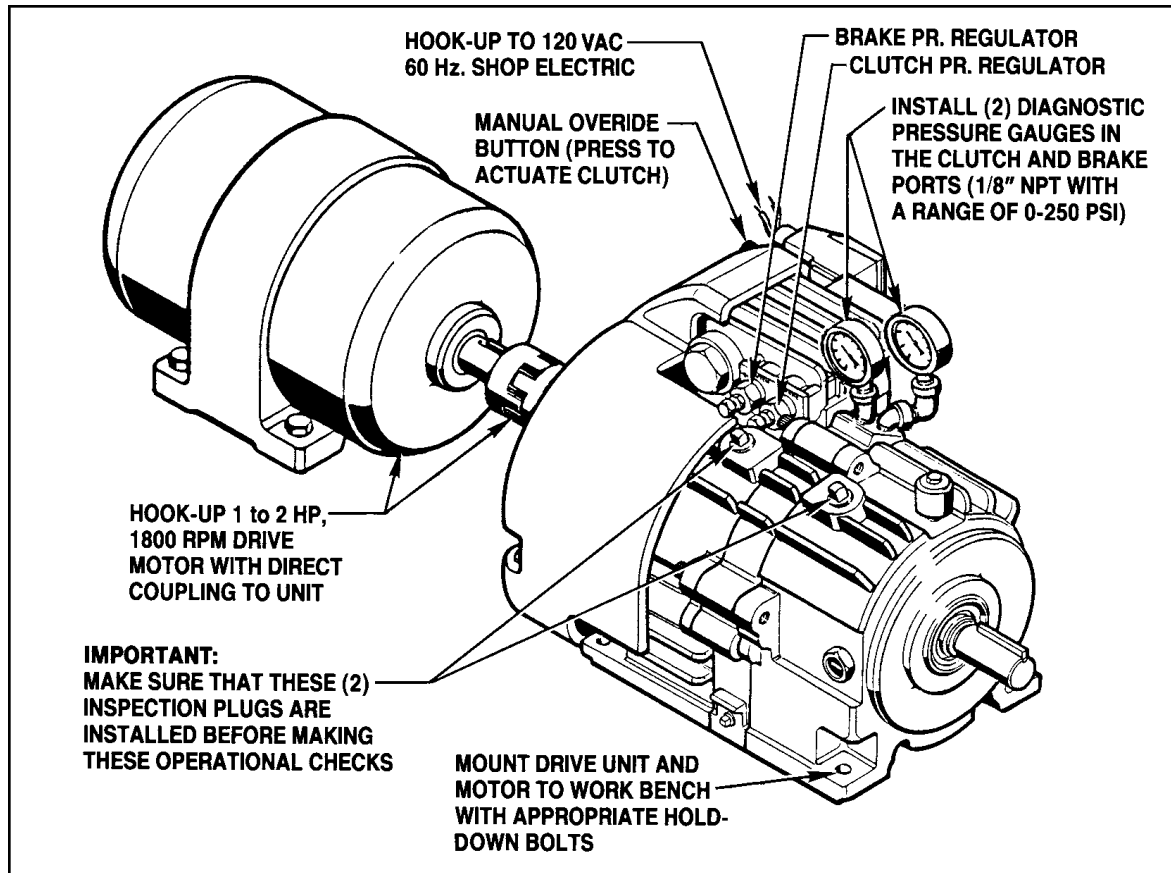

Figure 5.03 - Hydraulic Operational Checks

---

---

A further check would be to adjust the “Clutch” and “Brake” pressure regulators located in the manifold.

4. Loosen the lock-nuts on the regulators and with a 1/2” wrench turn the adjusting screw clockwise to increase the pressure and counter-clockwise to decrease the pressure. The “Manual Override” button has to be depressed to check and adjust the “Clutch” pressure.

## **5-5 CHECKING THE SOLENOID CONTROL VALVE AND DRIVE MOTOR OPERATION**

1. Hook-up the Solenoid Valve to 120. VAC, 60 Hz. shop electric.

Refer to **Section 3, INSTALLATION** for Electrical Diagram (*Figure 3.01*) and Electrical Connector (*Figure 3.02*).

2. Hook-up a 1 to 2 HP, 1800 RPM drive motor as per manufacturer’s specifications and the wiring diagram shown on the motor nameplate.
3. Turn on the drive motor and let the hydraulic pressure build up to the normal 120 PSIG. Energize the solenoid valve. (The LED light located in the electrical connector should come on.) The “Clutch” will activate and the output shaft should rotate.
4. De-energize the solenoid valve. Pressure will be applied to the “Brake” and the output shaft should stop.

# Section 6 - TROUBLESHOOTING

**CAUTION**  
 Open Disconnect to prime mover and lock it out while making repairs or checking machinery to avoid personal injury.

## 6-1 TROUBLESHOOTING CHART

SYMPTOM	POSSIBLE CAUSE	REMEDY	
<b>A.</b> Clutch and/or brake fails to engage or disengage properly.	1. Electrical control circuit.	a	
	2. Low piston pressure.	b, c	(See Note 1)
	3. Control valve not functioning properly.	d	
	4. Internal pressure leakage.	e	
	5. Low oil level.	f	
<b>B.</b> Picks up load too quickly.	1. Piston pressure too high.	g	(See Note 1)
<b>C.</b> Noise and vibration.	1. Mounted on poor foundation.	h	
	2. Misaligned couplings.	i	
	3. Damaged bearings.	j	
<b>D.</b> Drive overheats. (Oil Temperature above 225° F.)	1. Clutch or Brake fails to engage or disengage properly causing excessive slipping.	b, c, d	
	2. Inertia or resistance changed.	k	
	3. Improper oil level.	l	
	4. Fan blocked.	m	
<b>E.</b> Oil leakage	1. Bad oil seals.	n	
	2. Gaskets leaking.	o	
	3. Poor ventilation causing oil seals to leak.	p	
<b>F.</b> Oil leakage out breather.	1. Damaged seal around piston.	e	
	2. Oil level too high.	q	
<b>G.</b> Excessive shaft end play. (.020" Max.)	1. Input or output bearings damaged.	j	
<b>H.</b> Clutch or Brake does not repeat.	1. Piston pressure changed.	r	(See Note 1)
	2. Abnormal increase or decrease in oil operating pressure.	s	(See Note 2)

---

---

## NOTES

1. Install diagnostic pressure gauges in the clutch and brake ports when checking or adjusting the clutch or brake piston pressure.
2. Operating temperatures are important for installations requiring precise starting and stopping. Operating temperatures between 116° and 165°F are recommended. If the oil is allowed to drop to ambient temperatures overnight, the input shaft should be run for approx. 1/2 hr. before operating the driven machinery.

## 6-2 REMEDIES

- a. Check control circuit.
- b. Increase Piston pressure (See Note 1).
- c. Check for clogged filter or strainer and clean if necessary.
- d. Check valve operation and replace if necessary.
- e. Install pressure gauges as indicated in Note 1 and check the Clutch and Brake pressure. Leakage across the O-Rings and Liners would be indicated if the pressure does not build up.
- f. Check oil level and fill if necessary.
- g. Reduce piston pressure (See Note 1).
- h. Improve installation. Tighten foot bolts.
- i. Correct alignment.
- j. Disassemble to extent necessary and replace bearings.
- k. Check with Force Control Engineering.
- l. Check oil level and add or drain oil as necessary.
- m. Clean Fan shroud.
- n. Check for oil leakage around shafts and replace oil seals if necessary.
- o. Check for leakage between housings and tighten all external bolts.
- p. Remove breather and clean.
- q. Drain excess oil.
- r. Check piston pressure and adjust (See Note 1).
- s. Check operating temperature (See Note 2).

# Section 7 - DISASSEMBLY

## WARNING

Before attempting any repairs on the drive unit, open electrical disconnects to the drive motor and to the solenoid control valve. Lock them out to avoid any possibility of personal injury.

## 7-1 PRELIMINARY DISASSEMBLY PROCEDURE

1. Disconnect the drive unit and move it to a suitable work area.
  - a. Remove all necessary safety guards, belts, sheaves and couplings from the input and output ends.
  - b. Disconnect the electrical connector from the solenoid control valve by unscrewing the captive screw in the electrical connector and unplug the connector from the solenoid valve. (See Figure 7.01)

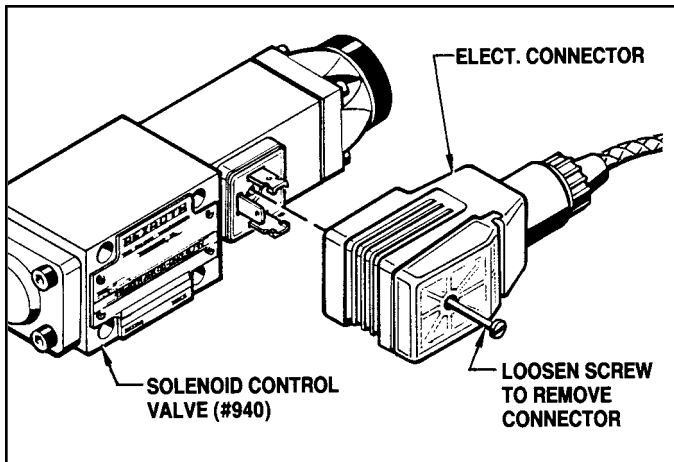

Figure 7.01 - Disconnecting The Electrical connector

- c. Remove all hold down bolts and proceed to move the drive unit to the suitable work area.
2. Remove the drain plugs at the bottom of the Piston Housing and drain all of the oil into a suitable container and either save or discard as the condition warrants.

## IMPORTANT

UNLESS THE UNIT IS TO BE COMPLETELY OVERHAULED, IT SHOULD ONLY BE DISASSEMBLED TO THE EXTENT NECESSARY TO GAIN ACCESS TO THE WORN OR DAMAGED PARTS.

One of the main features of the *Posidyne* Drive Units is easy access to the Clutch and Brake Stacks. The EL-02 Electric *Posidyne* is comprised of three main Sub-Assemblies as shown in *Figure 10.01* and with the removal of only (5) screws the Sub-Assemblies can be separated for access to the Clutch and Brake Stacks.

### The Sub-Assemblies are as follows:

1. Sub-Assemblies & Clutch and Brake Stacks.....(See Figure 10.01)
2. Input Housing Sub-Assembly..... (See Figure 10.02)
3. Piston Housing Sub-Assembly.....(See Figure 10.03)
4. Output Housing Sub-Assembly.....(See Figure 10.04)

## 7-2 SEPARATION OF MAIN SUB-ASSEMBLIES FOR ACCESS TO THE CLUTCH/BRAKE STACKS

(See Figure 10.01)

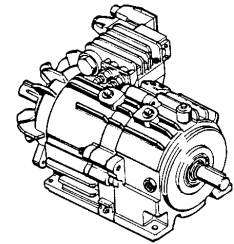

### 7-2-1 General Information

1. Jackscrew holes are provided in the Input Housing to aid in separation.
2. Do not attempt to reuse Gaskets (#53) and (#111). They must be replaced with new ones at Reassembly.
3. When removing the Clutch or Brake Stacks, always keep the Drive Plates (#13) and the Friction Discs (#12) in the same order as they were, when removed.

### 7-2-2 Removing The Fan Shroud

1. Unscrew and remove the (2) Screws (#950) and (2) Lockwashers (#951) from the Fan Shroud (#947). Pull the Fan Shroud away from the Input Housing Sub-Assembly.

### 7-2-3 Access To The Clutch Stack

2. Unscrew the (5) Screws (#69) and remove them with the (5) Lockwashers (#127) from the Input Housing Sub-Assembly.

- Utilizing the (2) jack-screw holes, separate the Input Housing Sub-Assembly from the Piston Housing Sub-Assembly.

**CAUTION**

**Pull the Input Housing Sub-Assembly straight back, when separating, to disengage the (4) Drive Pins from the Clutch Stack without damaging the Drive Plates (#13).**

- The **CLUTCH STACK** can now be removed from the output shaft spline.
- Remove and discard Gasket (#111) from the housing face.

**7-2-4 Access To The Brake Stack**

- Break the gasket seal between the Piston Housing Sub-Assembly and the Output Housing Sub-Assembly. Separate the two housings.
- The **BRAKE STACK** can now be removed from the output shaft spline.
- Remove and discard Gasket (#53).

**IMPORTANT REMINDER**

**When removing the CLUTCH/BRAKE STACKS, always keep the Drive Plates (#13) and the Friction Discs (#12) in the same order as they were removed.**

If repair or replacement of the **CLUTCH/BRAKE STACKS** is the only repair to be done, then proceed to **Section 8 - CLEANING AND INSPECTION**.

**DISASSEMBLY OF MAIN SUB-ASSEMBLIES**

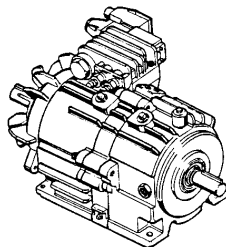

**7-3 INPUT HOUSING SUB-ASSEMBLY**

(See Figure 10.02)

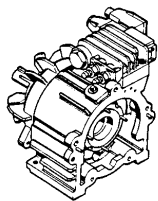

**7-3-1 Removal & Disassembly Of The Manifold & Control Valve**

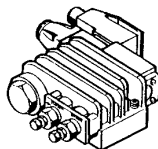

- Remove Screw (#928), (2) Screws (#927) and (3) Lockwashers (#944) from the Manifold (#905). Lift the Manifold (#905) off of the Input Housing. Remove and discard Gasket (#922).
- To inspect and clean Filter Element (#917), remove Filter Cap (#918), O-Ring (#921) and Spring (#919). Pull the Filter (#917) and the Filter Gasket (#920) out of the manifold.

**CAUTION**

**Be very careful not to drop the Filter Element, for any hard impact could break or damage it,**

Refer to **Section 8, CLEANING AND INSPECTION** for cleaning procedure of the Filter Element (#917).

- With a 7/8" open-end wrench, remove the (2) Relief Valve Cartridges (#906) from the manifold. Inspect and replace the Back-Up Rings and O-Rings if necessary.

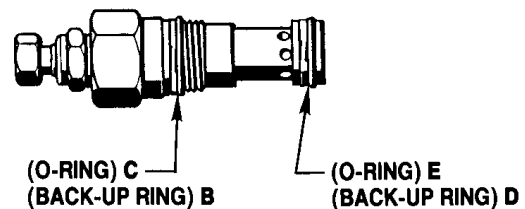

**NOTE: To order replacement O-Rings and Backup Rings for the Cartridge, specify kit #190-990010006,**

- Unscrew the (4) Screws (#930) and remove the Name Plate (#907), if necessary.
- Remove and inspect the (4) O-Rings (#941) from the Control Valve.

**7-3-2 Removing Cooling Fan From Input Shaft** (See Figure 10.02)

- Loosen (2) Set Screws (#949) and slide the Fan (#948) off of the Input Shaft (#2). Remove Key (#180) out of the Input Shaft.

**7-3-3 Removal & Cleaning Of The Suction Strainer (#912)** (See Figure 10.02)

- Remove (2) Screws (#926) and (2) Lockwashers (#945) from the front of the Pump Housing (#900).
- Take the Strainer Cover (#908) and the Gasket (#913) off of the Pump Housing. If the Gasket (#913) is not damaged it can be reused at Reassembly.
- Remove the Spring (#914) and pull the Suction Strainer (#912) out of the Pump Housing.

- Inspect and clean the Strainer as described in Section 8 - CLEANING AND INSPECTION.

### 7-3-4 Removal & Disassembly Of The Pump Assembly (See Figures 7.02 and 10.02)

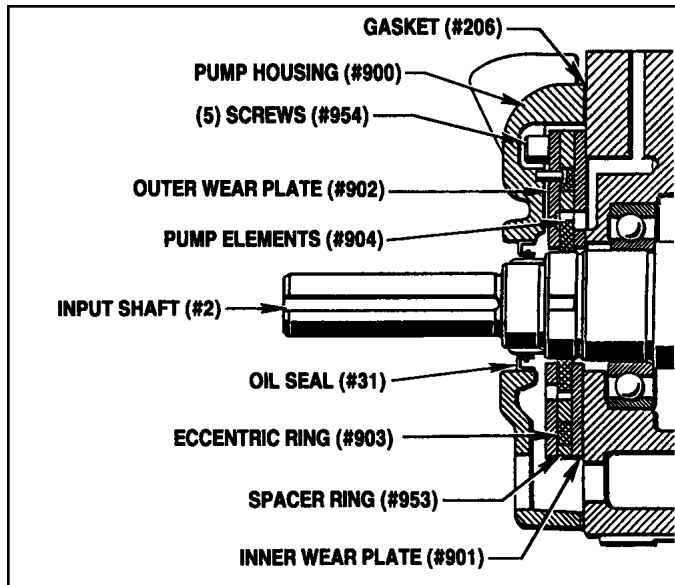

Figure 7.02 - Pump Disassembly

- Remove (6) Screws (#925) and (6) Lockwashers (#127) from the Pump Housing (#900).
- Break the gasket seal and remove the Pump Housing (#900) and the Gasket (#206) from the Input Housing (#8). Discard the gasket after removal.

#### CAUTION

Be careful not to damage the lip of the Oil Seal (#31) when removing the Pump Housing.

- Inspect the Oil Seal (#31) and if replacement is necessary press it out of the pump housing bore.
- Check the Wear Sleeve (#195) on the Input Shaft. If the Wear Sleeve is damaged and needs to be removed use the following procedure. (See Figure 7.03)

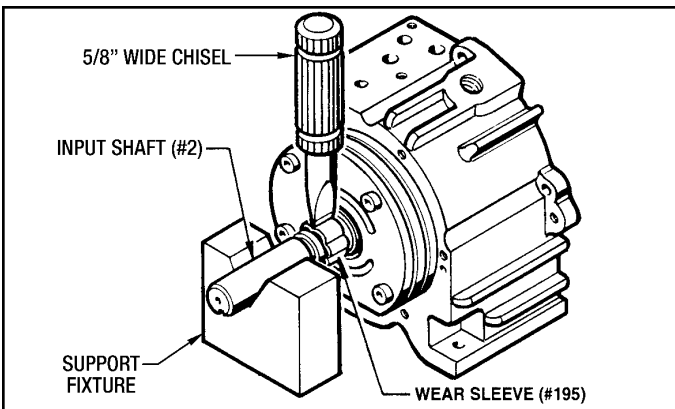

Figure 7.03 - Removing Wear Sleeve (#195)

With a mallet and a 5/8" wide chisel make 5 or 6 notches in the Wear Sleeve parallel to the Input Shaft. This will buckle the Wear Sleeve and release it from the shaft. It can now be removed by hand.

- Remove the (5) Screws (#954) from the Outer Wear Plate (#902). Slide the Wear Plate off the extended input shaft.
- Remove the Spacer Ring (#953), Eccentric Ring (#903) and the Hydraulic Pump Segments (#904) off of the input shaft. (See Important Note)

#### CAUTION:

When removing the Eccentric Ring (#903) be careful that the Pin (#957) and Spring (#958) in the Eccentric Ring does not fly away.

- Remove the Inner Wear Plate (#901) from the Input Housing.

#### IMPORTANT NOTE:

When you remove the Outer Wear Plate (#902), both Hydraulic Pump Segments (#904), Pump Spacer Ring (#953) and the Inner Wear Plate (#901) - be sure to mark the "OUTSIDE" or "INSIDE" of each part with a china marker or equivalent so they can be reassembled the same way as they were removed.

### 7-3-5 Removing The Input Shaft Sub-Assembly From The Input Housing

(See Figures 7.04 and 10.02)

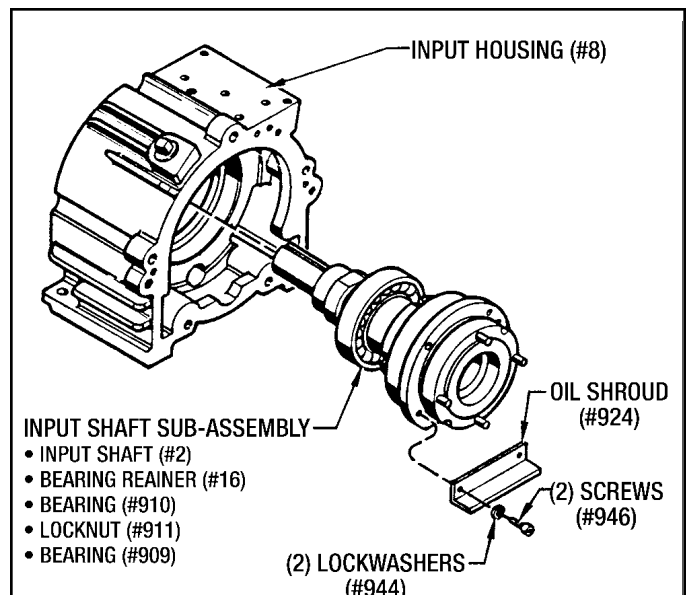
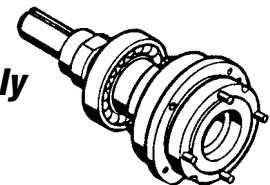

Figure 7.04 - Removing The Input Shaft

1. Unscrew and remove the (2) Screws (#946) and (2) Lockwashers (#944). Remove the Oil Shroud (#924) out of the Input Housing.
2. Pull the Input Shaft Sub-Assembly out of the Input Housing.

### 7-3-6 Input Shaft Disassembly

(See Figure 7.05)

**Do not attempt to disassemble the Input Shaft unless the Bearings need replaced.**

1. Using a standard 3-Jaw Bearing Puller, remove Bearing (#909) from the Input Shaft as shown in Figure 7.05.

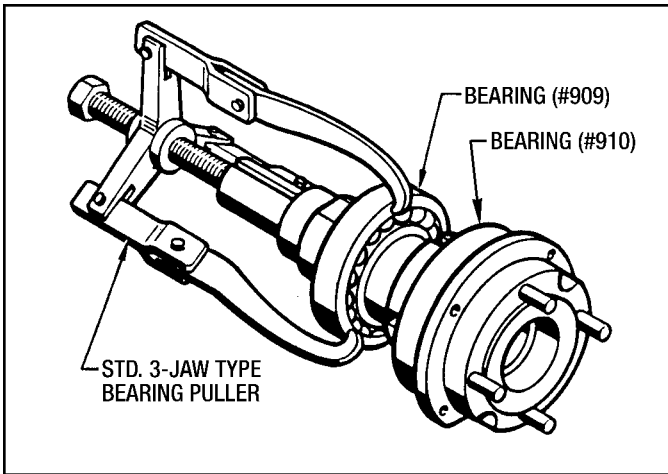
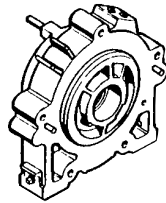

Figure 7.05 - Removing Bearing (#909)

2. Remove Locknut (#911). If Bearing (#910) needs to be replaced use the Bearing Puller to remove it as you did for Bearing (#909).
3. Take the Bearing Retainer (#16) off the Input Shaft.

### 7-4 PISTON HOUSING SUB-ASSEMBLY

(See Figure 10.03)



1. If the (3) Springs (#36) are still on the Piston, remove them at this time.

### 7-4-1 Removal Of Piston Liners & O-Rings

(See Figure 7.06)

1. Remove (6) Screws (#962) and (6) Washers (#963) from the Piston Retainer (#11). Using the (2) jack screw holes separate the Piston Retainer from the Piston Housing.
2. Remove the Liner (#42) and the O-Ring (#39) from the Piston Retainer (#11).

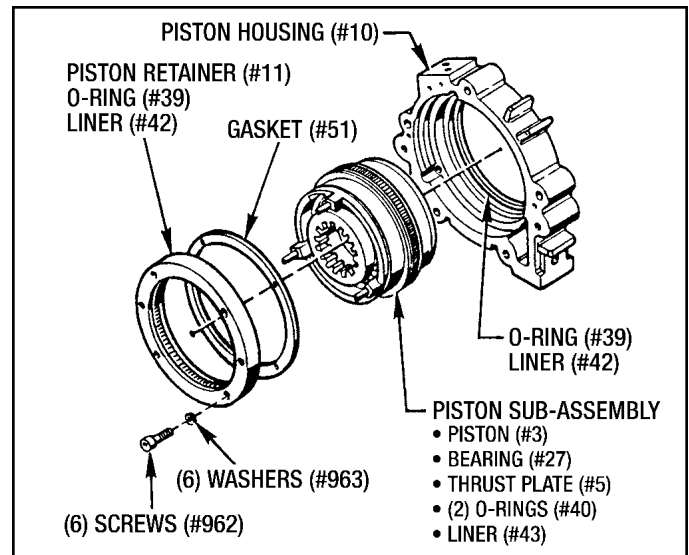

Figure 7.06 - Removing Piston From Piston Housing

3. Push the Piston Sub-Assembly out of the Piston Housing.
4. Remove and inspect the Liner (#43) and the (2) O-Rings (#40) from the Piston. Replace if necessary.
5. The Liner (#39) and O-Ring (#42) in the Piston Housing can also be removed for inspection and replacement if necessary.
6. The Gasket (#51) will also have to be removed from the Piston Housing. Discard the gasket.

### 7-4-2 Disassembly Of The Piston Sub-Assembly

**Do not attempt to remove the Bearing (#27) or Thrust Plate (#5) unless replacement is necessary.**

1. Using an Arbor Press as shown in Figure 7.07 press the Thrust Plate (#5) and Bearing (#27) out of the Piston (#3).

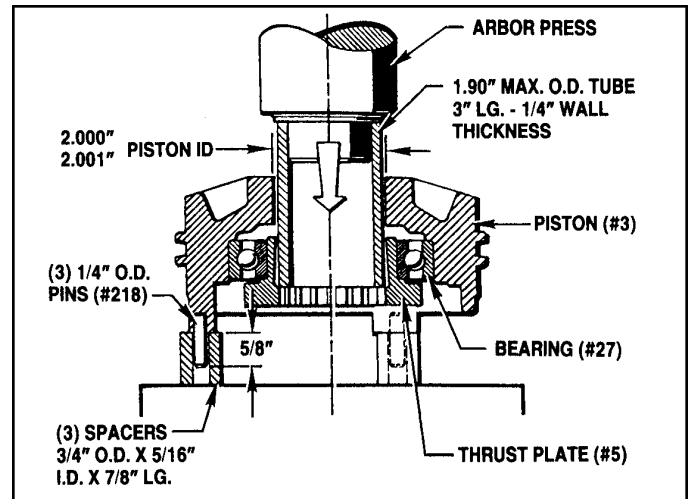

Figure 7.07 - Removing Bearing (#27)

**CAUTION**

Do not press on the Pins (#218). Use spacers as shown (or equivalent) in Figure 7.07.

2. If the Thrust Plate (#5) is to be used again, press it out of the Bearing (#27).

**7-5 OUTPUT HOUSING SUB-ASSEMBLY**

(See Figure 10.04)

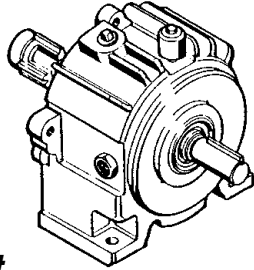

**7-5-1 Removing Output Shaft Sub-Assembly**

1. Remove the Key (#181) from the Output Shaft (#1).
2. Remove (4) Screws (#63) and (4) Lockwashers (#127) from the Bearing Retainer (#7). Remove the Bearing Retainer from the Output Housing (#9).
3. Pull the Output Shaft Sub-Assembly out the rear of the Output Housing. (See Figure 7.08)

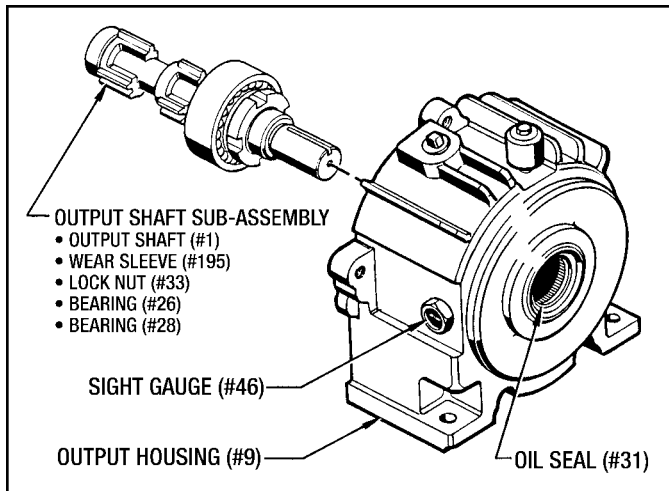

Figure 7.08 - Removing Output Shaft Sub-Assembly

**CAUTION**

Do not damage the lip of Oil Seal (#31) when pulling the Output Shaft out of the Housing.

4. Inspect the Oil Seal (#31) and if replacement is necessary, press it out of the housing.
5. Remove the Sight Gauge (#46) and the Air Breather (#45) for cleaning or replacement.

**7-5-2 Output Shaft Disassembly**

(See Figure 10.04)

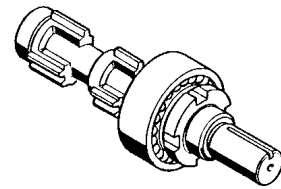

**DO NOT DISASSEMBLE THIS OUTPUT SHAFT UNLESS PART REPLACEMENT IS NECESSARY**

1. Remove the Locknut (#33).
2. Using a standard 3-Jaw Bearing Puller, remove Bearing (#26) from the shaft.
3. Also if the Pilot Bearing (#28) needs to be replaced, remove it from the shaft with a bearing puller.
4. If the Wear Sleeve (#195) needs to be replaced use the following procedure to remove it. (See Figure 7.09)

Place the Output Shaft in a suitable holding fixture and with a mallet and a 5/8" wide chisel make 5 or 6 notches in the sleeve parallel to the Output Shaft. This will buckle the sleeve and release it from the shaft. It can now be removed by hand.

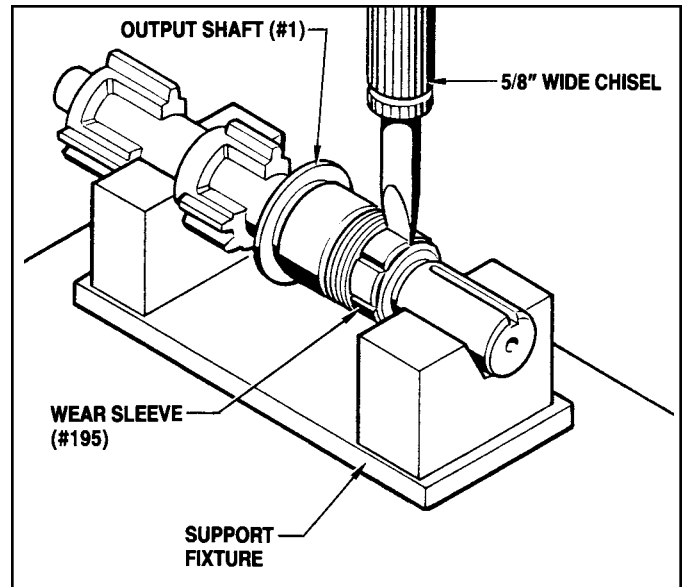

Figure 7.09 - Removing Wear Sleeve From Output shaft

**This completes the Disassembly Procedure for your EL-02 Electric Posidyne Clutch and Brake Unit.**

Proceed to **Section 8 - CLEANING AND INSPECTION.**

---

---

## Section 8 - CLEANING & INSPECTION

### WARNING

Petroleum based cleaning solvents are flammable. Open flames and smoking **MUST NOT BE PERMITTED** in the vicinity of these solvents.

### 8-1 CLEANING

1. Clean all metal parts in a suitable cleaning solvent and dry in a stream of low compressed air.
2. The Filter Element(#917), located in the Input Housing Manifold can be cleaned in a solvent.

### CAUTION

Do not drop or strike this Filter Element against any hard surface. It is very porous and brittle and could possibly shatter upon impact.

3. To clean the Suction Strainer (#912), located in the Pump Housing, all of the oil will first have to be drained out of the unit. Do not use solvent to clean this strainer. Use only warm soapy water and dry in a stream of low compressed air. Wipe with a clean, dry and lint free rag.
4. The Clutch and Brake Drive Plates (#13) can be cleaned in a solvent, but DO NOT clean the Friction Discs (#12) in a solvent. Use only a clean, dry and lint free rag to clean these Friction Discs. (Solvent will damage the resilient paper-based friction material used on the Discs.)

### REMINDER

Keep the Friction Discs and Drive Plates in the same order as they were removed.

### 8-2 INSPECTION

After cleaning, inspect all parts for cracks, distortion, scoring, nicks, burrs or any other damage that would affect the operation of the drive unit. Pay particular attention to the following:

1. Check the Friction Disc wear surfaces for scoring, galling or any evidence of uneven wear.
2. Check the Drive Plates for scoring or galling. Make sure that they are flat and that no warping is evident. If a perceptible ridge is worn in any of the drive plates, replace all of the Drive Plates and Friction Discs as a complete set.
3. Carefully check the Piston (#3), Thrust Plate (#5) and bore surfaces for nicks, scratches, scoring or any damage that would affect the operation or cause leakage.
4. Pay particular attention to the Wear Sleeves (#195) and shafts in the area of the oil seals. Check for nicks, scratches or any damage which would cause leakage. Also check the lip of the Oil Seals (#31) very carefully to see that they are not worn or damaged in any way.
5. Check the surfaces of the Hydraulic Pump Element (#904), Wear Plates (#901) and (#902) and the Inside Diameter of the Reversing Ring (#903) for any scoring, galling or any damage that would affect the operation of the pump.
6. Check the gasket surfaces on the main housings to see if any scratching or damage was done when the old gaskets were removed.
7. It is not necessary to remove the ball bearings to check their operation. Slowly rotate the free race of each bearing by hand checking to see if it turns freely without any rough or flat spots.

### 8-3 REPAIR AND REPLACEMENT

A fine stone or crocus cloth may be used to remove minor surface defects from parts so long as the operating or sealing action of the part is not affected. The use of coarser abrasives or other machining methods should not be attempted. Otherwise, damaged parts should be replaced. Replacement is recommended also for the following:

1. Replace all O-Rings, Liners, Gaskets and Oil Seals removed during the course of disassembly.
2. Replace Friction Discs and Drive plates in complete sets only.

# Section 9 - REASSEMBLY

## 9-1 GENERAL REASSEMBLY INSTRUCTIONS

1. Lubricate all O-Rings and the lips of Oil Seals with the same oil used in the drive unit immediately before reassembly and installation of mating parts.
2. The Piston O-Ring Liner (#43) will be easier to install if heated in an oven to 200° F max.
3. The installation of press-fitted parts can be made easier by heating the outside parts in an oven. Heat Bearings and Wear Sleeves to 250° F max.

### CAUTION

Wear suitable gloves when handling heated parts.

4. Apply Gasket Sealant (**Permatex #3D**) or equivalent to all flat gaskets except the following:
  - a. Suction Strainer Gasket (#913) located in the Pump Housing (#900).
5. Place a light coating of Gasket Sealant (**Permatex #3D**) in the bores for both Oil Seals (#31) immediately before pressing them into the bores.
6. Use Cap screw Adhesive (Loctite #217) or equivalent when installing the following parts:
  - a. Locknut (#33) located on the Output Shaft.
  - b. Locknut (#911) on the Input Shaft.

(Use this adhesive sparingly and clean off any excess with **Loctite #755 Cleaner**.)
7. Use (**Loctite #620**) Bearing Retainer Compound on the I.D. and O.D. of Bearing (#27) for installation of the Bearing (#27) and the Thrust Plate (#5) into the Piston (#3).
8. Use an appropriate Pipe Tap Sealing Compound when installing any pipe fittings or pipe plugs.

## REASSEMBLY OF MAIN SUB-ASSEMBLIES

THE REASSEMBLY PROCEDURE IS BASICALLY JUST THE REVERSE ORDER OF THE PREVIOUS DISASSEMBLY PROCEDURE.

## 9-2 OUTPUT HOUSING REASSEMBLY

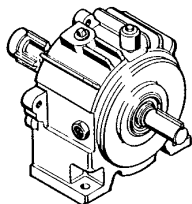

## 9-2-1 Output Shaft Sub-Assembly

(See Figure 10.04)

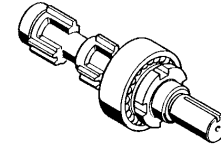

1. Using an Arbor Press and appropriate support tooling, press the Wear Sleeve (#195) onto the Output Shaft (#1).
2. Next, press the Bearings (#28) and (#26) onto the Output Shaft. Use an Arbor Press.
3. Apply Adhesive (**Loctite #271**) or equivalent, to the Locknut (#33) and install it onto the shaft.

## 9-2-2 Output Housing Sub-Assembly

(See Figure 9.01)

1. Apply a light coat of Gasket Sealant (**Permatex #3D**) in the oil seal bore in the Output Housing (#9). Press the Oil Seal (#31) into the housing bore.
2. Lubricate the lip of the Oil Seal (#31) and the Wear Sleeve with the same oil used in the drive unit.
3. Slide the pre-assembled Output Shaft into the rear of the Output Housing being careful not to damage the Oil Seal Lip with the Keyway in the Output Shaft. (See Figure 9.01)

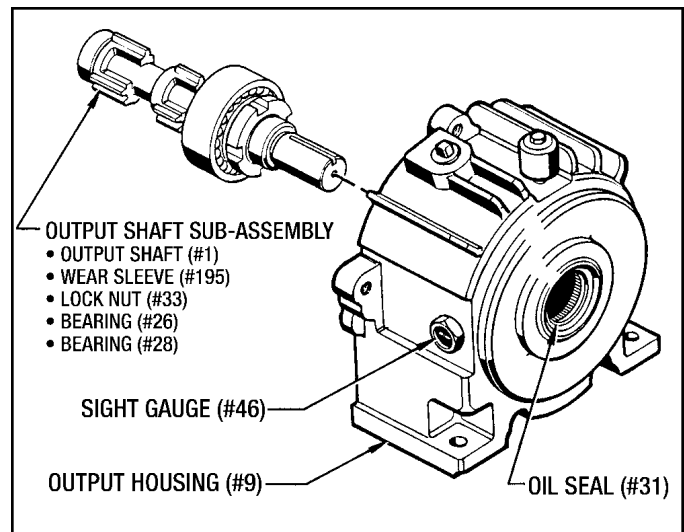
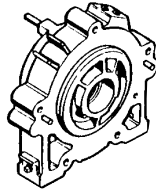

Figure 9.01 - Output Housing Reassembly

4. Attach the Bearing Retainer (#7) with (4) Screws (#63) and (4) Lockwashers (#127).
5. Reinstall the Air Breather (#45), Sight Gauge (#46) and all pipe plugs removed.
6. Install the Key (#181) back into the Output Shaft.

## 9-3 PISTON HOUSING REASSEMBLY

(See Figure 10-3)



### 9-3-1 Piston Sub-Assembly

(See Figure 9-2)

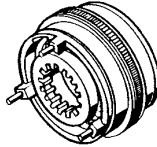

1. Apply (**Loctite #620**) Bearing Retainer Compound to the O.D. of Bearing (#27) and lightly press it into the Piston (#3).
2. Apply the (**Loctite #620**) to the I.D. of Bearing (#27) and lightly press the Thrust Plate (#5) into the Bearing (#27).

#### CAUTION

When assembling the Bearing (#27) and the Thrust Plate (#5) into the Piston, be careful not to overpress. This could result in damage to the Bearing.

3. Install (2) O-Rings (#40) and the Liner (#43) onto the O.D. of the Piston.

#### REMINDER

Lubricate the O-Rings (#40) before installing them into the Piston, Heating the Liner (#43) in an oven to 200° F max, will make it easier to install it on the Piston.

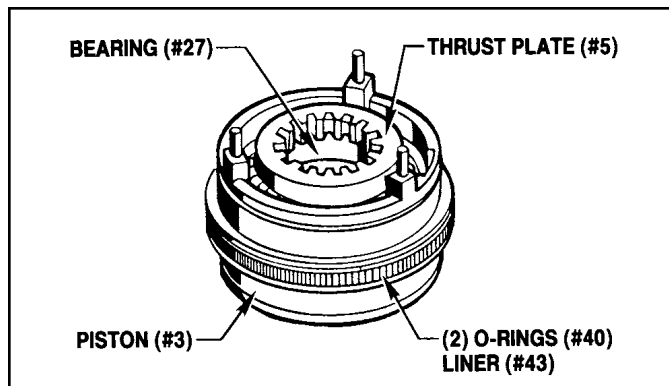

Figure 9.02 - Piston Sub-Assembly

### 9-3-2 Installing The Piston Sub-Assembly Into The Piston Housing (See Figure 9.03)

1. Lubricate the O-Ring (#39) and install it along with the Liner (#42) into the Piston Housing (#10).
2. Slide the Piston Sub-Assembly into the Piston Housing.

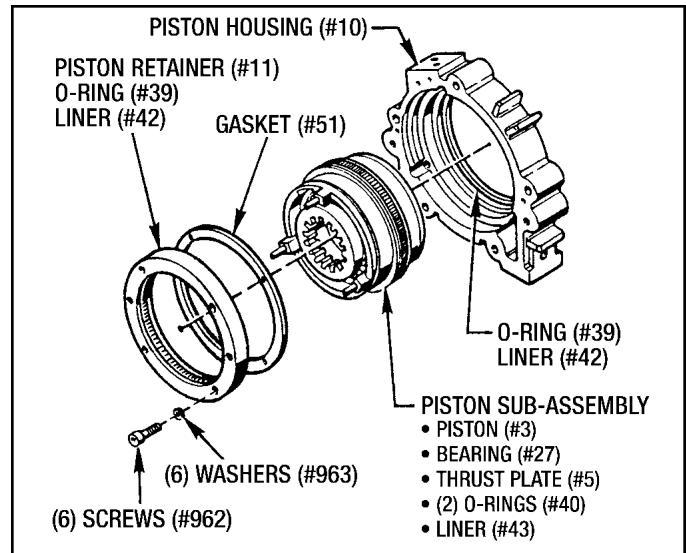
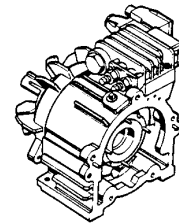

Figure 9.03 - Piston Housing Sub-Assembly

3. After lubricating the O-Ring (#39) place it and the Liner (#42) into the Piston Retainer (#11).
4. Using (**Permatex #3D**) Gasket Sealant, install the Gasket (#51) into the Piston Housing.
5. After applying another coat of (**Permatex #3D**) to the gasket face, place the Piston Retainer(#11) into the housing and attach with (6) Screws (#962) and (6) Washers (#963).
6. Reinstall the pipe plugs (#73) and (#74).

## 9-4 INPUT HOUSING REASSEMBLY

(See Figure 10.02)



### 9-4-1 Input Shaft Sub-Assembly

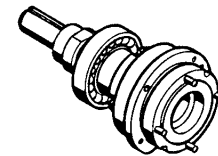

#### NOTE:

The following parts will be easier to install on the Input Shaft If you first heat them up in an oven to 250° F.

1. Wear Sleeve (#195).
2. Bearing (#909).
3. Bearing (#910).

**REMEMBER TO WEAR SUITABLE GLOVES WHEN HANDLING HEATED PARTS.**

1. Place the Bearing Retainer (#16) over the end of the Input Shaft.

2. Press the Bearing (#910) onto the Input Shaft using an arbor press.
3. Apply (**Loctite #271**) adhesive to the threads of the Locknut (#911) and install it onto the Input Shaft.
4. Using an Arbor Press, install the Bearing (#909) onto the Input Shaft.
5. If the Key (#37) was removed during disassembly, install it into the Input Shaft (#2).

### 9-4-2 Installing The Assembled Input Shaft Into The Input Housing

(See Figure 9.04)

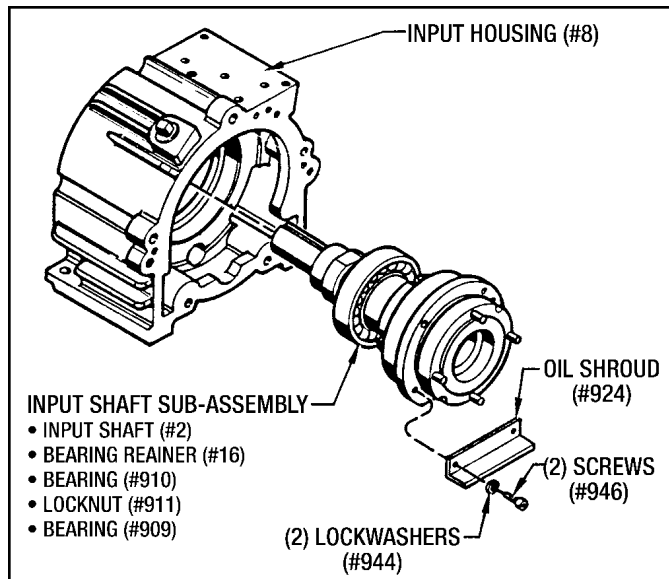

Figure 9.04 - Installing Input Shaft Into Input Housing

1. Slide the assembled Input Shaft into the Input Housing.
2. Attach the Oil Shroud (#924) and the Bearing Retainer (#16) with (4) Screws (#946) and (4) Lockwashers (#944).

### 9-4-3 Hydraulic Pump Reassembly

(See Figures 9.05, 9.06, 9.07 and 10.02)

#### IMPORTANT NOTE:

It is important that all of the Hydraulic Pump parts, described in this Section 9-4-3 are reassembled in exactly the same way as they were removed. (Refer to "INSIDE" and "OUTSIDE" markings made at disassembly.)

1. Place the Input Housing face down on the work table with the protruding Input Shaft extending upwards.
2. Position the Inner Wear Plate (#901) on the Input Housing with the flat at the bottom.

3. Manually turn the Input Shaft so the Key (#37) is positioned at the top as shown in Figure 9.05.
4. Slide the Inner Pump Segment (#904) down over the Input Shaft aligning the keyway with the Key (#37). (See Figure 9.05)

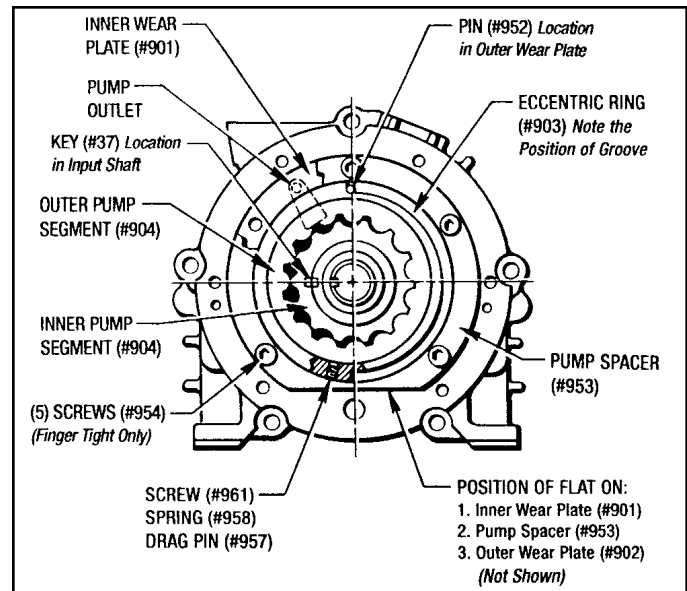

Figure 9.05 - Hydraulic Pump Assembly (End View)

5. Place the Outer Pump Segment (#904) on the Inner Wear Plate (#901) and in position with the Inner Pump Segment. (See Figure 9.05)
6. Install the Drag Pin (#952) into the Outer Wear Plate (#902) leaving .005" clearance between the bottom of the Eccentric Ring (#903) groove and the pin. (See Figure 9.06). Set this aside for later assembly.

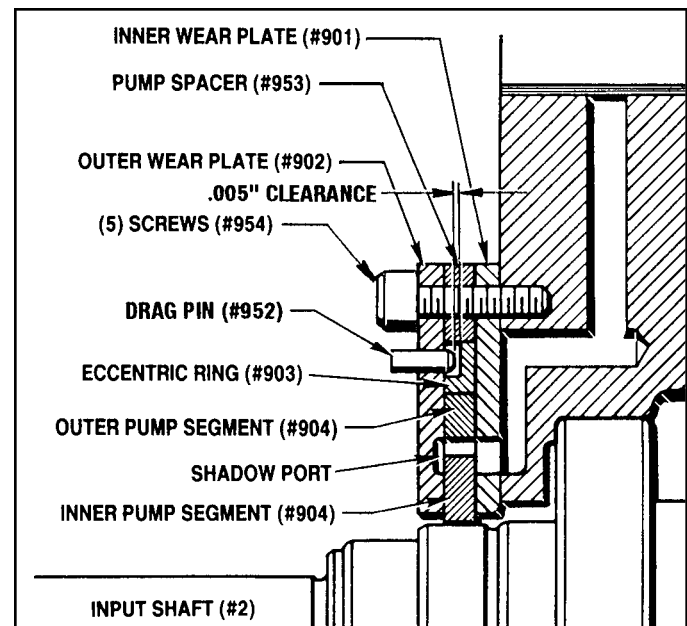

Figure 9.06 - Hydraulic Pump Assembly (Cross Section)

7. Position the Eccentric Ring (#903) over the Outer Pump Segment (#904) with the eccentric groove at the top as shown in *Figure 9.05*.
8. Install the Drag Pin (#957), Spring (#958) and Set Screw (#961) into the Eccentric Ring (#903) Use Red Loctite #262 on the set screw threads. Tighten until the head of the screw is flush with the outside diameter of the Eccentric Ring.
9. Position the Pump Spacer (#953) so the flat is at the bottom as shown in *Figure 9.05*.
10. Place the Outer Wear Plate (#902) into position with the flat at the bottom. Make sure the Drag Pin (#952) fits into the eccentric ring groove and the "Shadow Port" cavity in the Outer Wear Plate is facing downward.
11. Insert the (5) Screws (#954) into the Outer Wear Plate (#902). Use Blue Loctite (**Removable Threadlocker #242**) on the threads. **Only finger tighten at this point.**
12. The concentric alignment of the Pump Assembly must be checked with a magnetic dial indicator placed on the end of the Input Shaft as shown in *Figure 9.07*. Rotate the input shaft 180° and note runout reading. If necessary, adjust position of the Pump Assembly with a light tap using a small hammer: Continue this alignment procedure until the maximum runout on the O.D. of the Pump Spacer is .001" or less. Tighten the (5) Screws (#954).

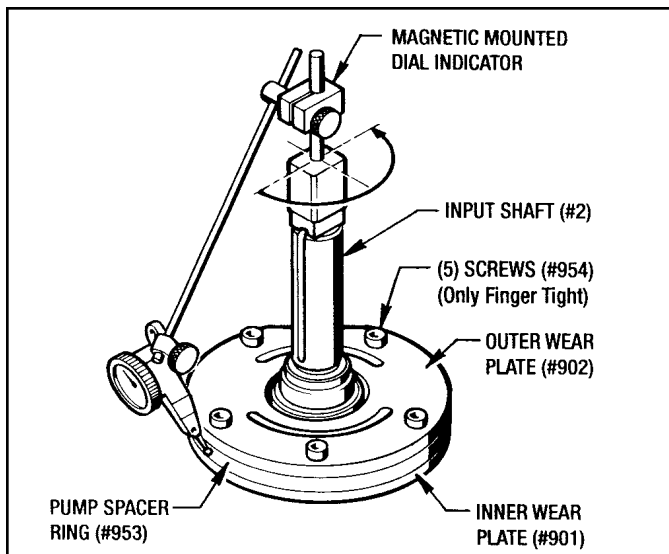

Figure 9.07 - Checking Concentric Alignment

13. Press the Wear Sleeve (#195) onto the Input Shaft with an Arbor Press.

### 9-4-4 Reassembly Of The Pump Housing, Suction Strainer & Cooling Fan

(See Figures 9.08 and 10.02)

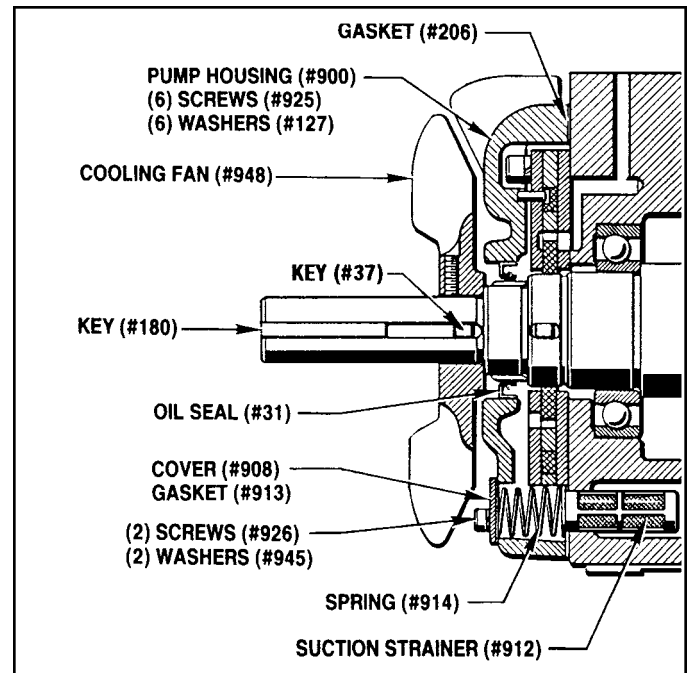

Figure 9.08 - Pump Housing, Suction Strainer & Cooling Fan

1. Apply a thin coat of (**Permatex #3D**) sealant to the inner bore of the Pump Housing (#900) and press the Oil Seal (#31) into the housing.
2. Using (**Permatex #3D**) gasket sealant, attach the Gasket (#206) to the pump housing inner face.
3. Lubricate the Oil Seal lip and slide the Pump Housing over the end of the Input Shaft, being careful not to damage the oil seal lip. Attach the Housing with (6) Screws (#925) and (6) Lockwashers (#127).
4. Insert the Suction Strainer (#912) and Spring (#914) into the Pump Housing.
5. Attach the Suction Strainer Cover (#908) and Gasket (#913) with (2) Screws (#926) and (2) Lockwashers (#945). (**Do not use any gasket sealant on this gasket.**)
6. Reinstall the Keys (#37) and (#180) into the Input Shaft (#901).
7. Slide the Cooling Fan (#958) onto the Input Shaft and lock it on with the Set Screw (#949).

### 9-4-5 Input Manifold Reassembly

(See Figure 10.02)

#### A. Relief Valve Cartridges

1. Attach the Name Plate (#907) to the Manifold (#905) with (4) Screws (#930).
2. First lubricate the O-Rings and Back-up Rings on the Cartridges then screw both Relief Valve Cartridges (#906) into the Manifold.

## B. Filter Replacement

1. Insert the Filter Gasket (#920), Filter (#917) and the Spring (#919) into the Manifold.
2. Lubricate the O-Ring (#921) and place it on the Filter Cap (#918). Screw the Filter Cap into the Manifold.

## C. Control Valve Mounting

1. Lubricate and install the (4) O-Rings (#941) into the Control Valve counterbores.
2. Attach the Control Valve (#940) to the rear of the Manifold with (4) Screws (#929) and (4) Lockwashers (#943).

## D. Mounting The Manifold Ass'y. To The Input Housing

1. Mount the Gasket (#922) to the top of the Input Housing. Use **(Permatex: #3D)** gasket sealant sparingly. Make sure the (4) pressure ports in the Input Housing and the Manifold are clean and free of any gasket sealant.
2. Attach the Manifold Assembly with (2) Screws (#927), (1) Screw (#928) and (3) Lockwashers (#944).

## 9-5 MAIN SUB-ASSEMBLIES AND CLUTCH/BRAKE STACKS INSTALLATION

(See Figure 10.01)

1. Place the Output Housing Sub-Assembly in a vertical position with the Output Shaft pointing downward.
2. Install the Brake Stack, as shown in *Figure 10.01*, onto the Output Shaft Spline aligning the (4) holes in the Drive Plates (#13) with the (4) extended pins in the Output Housing.
3. Install the Gasket (#53) and the Piston Housing Sub-Assembly onto the Output Housing. Use **(Permatex #3D)** on both gasket surfaces.
4. Place the Clutch Stack, as shown in *Figure 10.01*, onto the Output Shaft Spline. Make sure the (4) holes

in the Drive Plates are aligned up with each other and in position to receive the (4) pins in the Input Shaft.

5. Place the (3) Springs (#36) onto the pins extending from the Piston.
6. Apply gasket sealant **(Permatex #3D)** to the gasket surfaces and install Gasket (#111) to the Piston Housing.
7. Lower the Input Housing Sub-Assembly onto the Piston Housing making sure the Drive Pins in the Input Shaft mate with the holes in the Drive Plates. Also make sure the Pilot Bearing (#28) on the end of the Output Shaft is centered into the Input Shaft.

### CAUTION

**Do not force the drive pins into the drive plates. This could damage the drive plates.**

8. Insert the (5) Screws (#69) and (5) Lockwashers (#127) into the Input Housing and evenly tighten them down to compress the (3) Springs (#36)
9. Attach the Fan Shroud (#947) with (2) Screws (#947) and (2) Lockwashers (#951).

## 9-6 FINAL REASSEMBLY

1. Replace all pipe plugs removed for inspection or disassembly.
2. Fill the Drive Unit with Mobil Automatic Transmission Fluid type "F" or Mobil Multi-Purpose Automatic Transmission Fluid, as indicated in **Section 4 Lubrication**.

### NOTE:

Other fluids may be specified for special drives. Check the name tag.

3. Completely checkout the Operation as described in **Section 5, OPERATIONAL CHECKS** before placing the Drive Unit back into service

# Section 10 - ORDERING SPARE PARTS

## 10-1 GENERAL INFORMATION

This section illustrates, lists and describes all available repair parts for the EL-02 Electric *Posidyne* Clutch/Brake Drive Unit. Exploded view drawings with Reference Numbers are used to identify the various parts in the drive unit. These Reference Numbers are listed in the parts list along with the Part Name and Quantity used.

## 10-2 FACTORY REBUILD SERVICE

Reconditioning service is offered by Force Control Industries, Inc. at the factory. Before returning a unit for this service, be sure to first contact the Force Control Service Sales Dept. for authorization and shipping instructions. Force Control cannot be responsible for units returned to the factory without prior notice or authorization.

Care must be given to the packaging of returned drives. Always protect the mounting feet by attaching the unit to a suitable skid. Shipment-damaged drives always delay repairs. Describe the problem experienced on your shipping papers whenever possible.

### SHIPPING ADDRESS:

**Force Control Industries, Inc.**  
3660 Dixie Highway  
Fairfield, Ohio 45014

**Telephone: 1-513-868-0900**

**Fax: 1-513-868-2105**

**E-Mail: [info@forcecontrol.com](mailto:info@forcecontrol.com)**

**Web: [www.forcecontrol.com](http://www.forcecontrol.com)**



## 10-3 MINOR AND MAJOR OVERHAUL KITS

Minor and Major Overhaul Kits are available upon request as an option from the Force Control factory.

Minor Overhaul Kits - Includes all Gaskets, O-Rings, Oil Seals, Bearings, Drive Plates, Friction Disc, Liners, Springs and Wear Sleeves. These parts are indicated with an (\*) in the parts listings. Major Overhaul Kits - Includes all parts in the Minor Overhaul Kit plus a new Thrust Plate, Locknuts, Oil Filter, Suction Strainer, Sight Gauge, Air Breather and Mating Rings. These parts are indicated with an (\*\*) in the parts listings.

## 10-4 DRIVE MOTORS

The Drive Motors used with the EL-02 are standard and may be repaired or replaced by any qualified motor rebuild facility or supplier.

## 10-5 NAME PLATE

The Model Number and Serial Number for your EL-02 is given on the unit name plate. Be sure to include both numbers when ordering any repair parts.

<b>Posidyne</b>		<input type="checkbox"/> CLUTCH/BRAKE
		<input type="checkbox"/> CLUTCH ONLY
MODEL NO.	<input type="text"/>	
SERIAL NO.	<input type="text"/>	
<b>FORCE CONTROL INDUSTRIES, INC.</b>		
Fairfield, Ohio		
	USE MOBIL® ATF 210	

## 10-6 ORDERING REPAIR PARTS

When ordering repair parts, please specify all of the following information:

1. Drive Unit Model Number (On the Name Plate).
2. Drive Unit Serial Number (On the Name Plate).
3. Part Reference Number (From the Parts List and Exploded View Drawing).
4. Part Name (From the Parts List).
5. Quantity (From the Parts List).
6. Complete Shipping Information.

Failure to include information for items 1 through 5 will only delay your parts order. Unless another method is specified for item 6, parts weighing less than 150 lbs. will be shipped United Parcel Service and parts weighing more than 150 lbs. will be shipped motor freight. Air freight and other transportation services are available, but only if specified on your order.

## Main Sub-Assemblies and Clutch/Brake Stacks (Figure 10.01)

REF. No.	PART NAME	QTY.	REF. No.	PART NAME	QTY.
*12	Friction Disc .....	7	*111	Gasket .....	1
*13	Drive Plate .....	8	127	Lockwasher .....	5
*36	Spring .....	3	947	Fan Shroud .....	1
*53	Gasket .....	1	950	Soc. Hd. Cap Screw .....	2
69	Soc. Hd. Cap Screw .....	5	951	Lockwasher .....	2

\* Indicates parts in Minor Overhaul Kit.

# Main Sub-Assemblies and Clutch/Brake Stacks

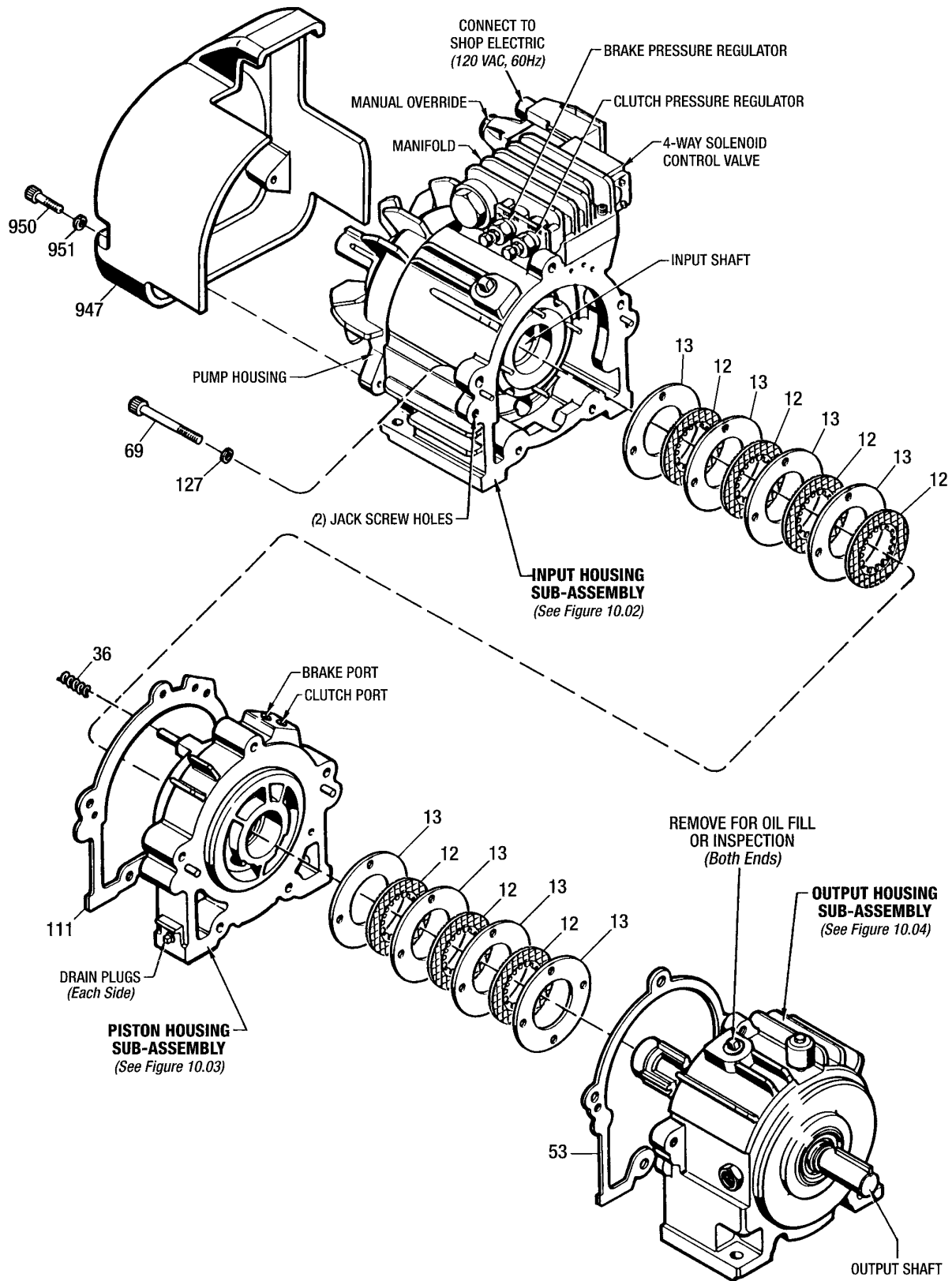

Figure 10.01 - Main Sub-Assemblies & Clutch/Brake Stacks

## Input Housing Sub-Assembly (Figure 10.02)

REF. No.	PART NAME	QTY.	REF. No.	PART NAME	QTY.
2	Input Shaft . . . . .	1	*920	Filter Gasket . . . . .	1
8	Input Housing . . . . .	1	*921	Filter O-Ring . . . . .	1
14	Pipe Plug, Sq. Hd. . . . .	1	*922	Manifold Gasket . . . . .	1
16	Bearing Retainer . . . . .	1	923	Dowel Pin . . . . .	2
*31	Oil Seal . . . . .	1	924	Oil Shroud . . . . .	1
37	Key . . . . .	2	925	Soc. Hd. Cap Screw . . . . .	6
68	Dowel Pin . . . . .	2	926	Soc. Hd. Cap Screw . . . . .	2
121	Dowel Pin . . . . .	4	927	Soc. Hd. Cap Screw . . . . .	2
127	Lockwasher . . . . .	6	928	Soc. Hd. Cap Screw . . . . .	1
180	Key . . . . .	1	929	Soc. Hd. Cap Screw . . . . .	4
*195	Wear Sleeve . . . . .	1	930	Rd. Hd. Machine Screw . . . . .	4
*206	Gasket . . . . .	1	940	Directional Control Valve . . . . .	1
900	Pump Housing . . . . .	1	*941	O-Ring . . . . .	4
901	Wear Plate, Inner . . . . .	1	943	Lockwasher . . . . .	4
902	Wear Plate, Outer . . . . .	1	944	Lockwasher . . . . .	5
903	Eccentric Ring . . . . .	1	945	Lockwasher . . . . .	2
904	Hydraulic Pump Segments . . . . .	1	946	Soc. Hd. Cap Screw . . . . .	2
905	Manifold . . . . .	1	948	Fan . . . . .	1
906	Relief Valve Cartridge . . . . .	2	949	Soc. Set Screw . . . . .	2
907	Name Plate . . . . .	1	952	Dowel Pin . . . . .	1
908	Strainer Cover . . . . .	1	953	Pump Spacer Ring . . . . .	1
*909	Ball Bearing . . . . .	1	954	Soc. Hd. Cap Screw . . . . .	5
*910	Ball Bearing . . . . .	1	957	Drag Pin . . . . .	1
**911	Locknut . . . . .	1	958	Drag Pin Spring . . . . .	1
**912	Suction Strainer . . . . .	1	961	Soc. Set Screw . . . . .	1
*913	Strainer Cover Gasket . . . . .	1	***B	Back-Up Ring . . . . .	2
**914	Spring . . . . .	1	***C	O-Ring . . . . .	2
**917	Filter . . . . .	1	***D	Back-Up Ring . . . . .	2
918	Filter Cap . . . . .	1	***E	O-Ring . . . . .	2
**919	Filter Spring . . . . .	1			

\* Indicates parts in the Minor Overhaul Kit.

\*\* Indicates parts in the Major Overhaul Kit.

*(This Major Overhaul Kit also includes all parts in the Minor Overhaul Kit.)*

\*\*\* Order replacement parts as Kit # 190-9900100006.

# Input Housing Sub-Assembly

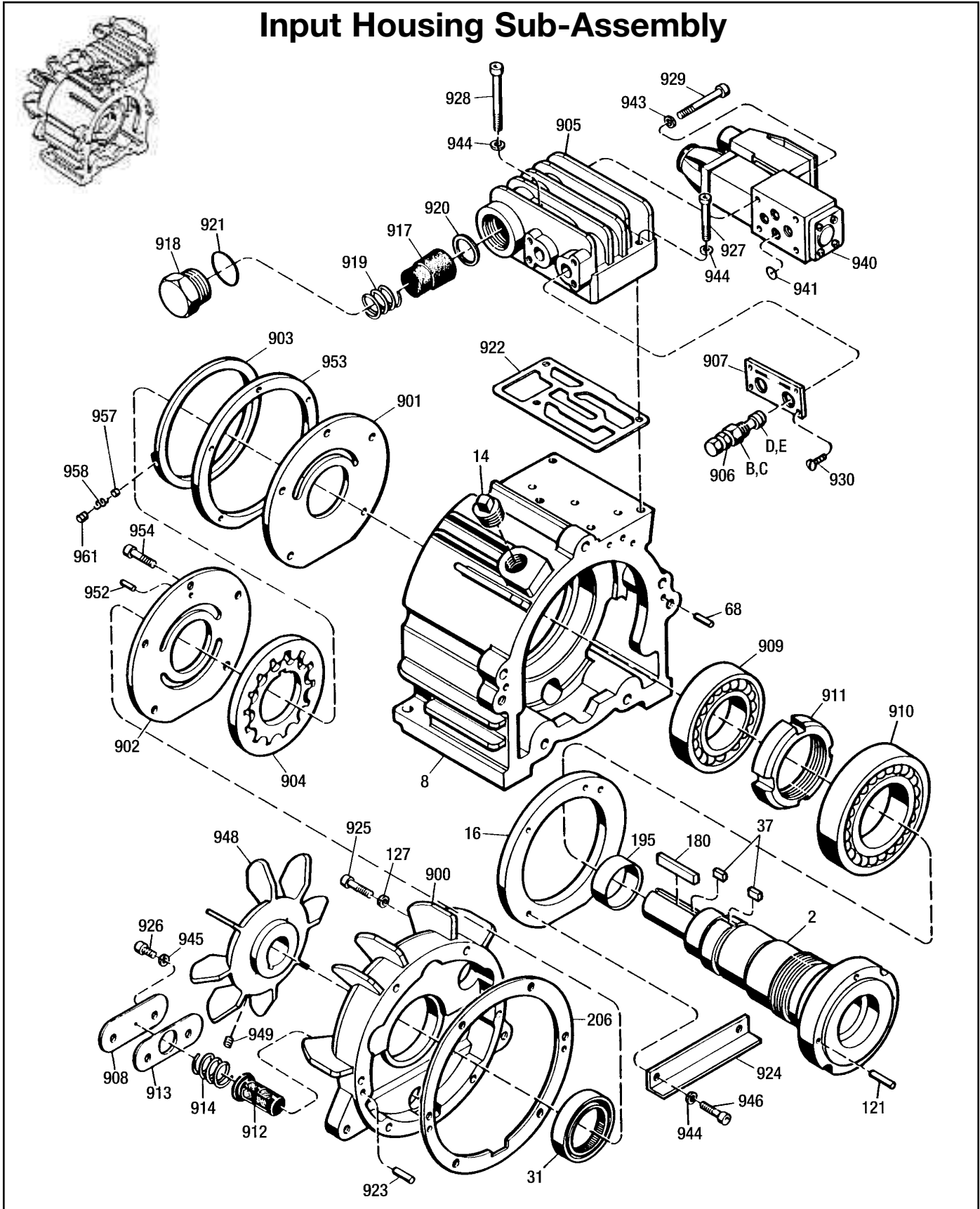

Figure 10.02 - Input Housing Sub-Assembly

## Piston Housing Sub-Assembly

(Figure 10.03)

REF. No.	PART NAME	QTY.	REF. No.	PART NAME	QTY.
3	Piston . . . . .	1	68	Dowel Pin . . . . .	2
**5	Thrust Plate . . . . .	1	73	Pipe Plug, Sq. Hd. . . . .	2
10	Piston Housing . . . . .	1	74	Pipe Plug . . . . .	2
11	Piston Retainer . . . . .	1	218	Dowel Pin . . . . .	3
*27	Ball Bearing . . . . .	1	959	Air Connection Fitting Assembly . . . . .	2
*39	O-Ring . . . . .	2	960	Air Connection Fitting . . . . .	2
*40	O-Ring . . . . .	2	961	O-Ring . . . . .	2
*42	Liner, I.D. Sealing . . . . .	2	962	Soc. Hd. Cap Screw . . . . .	6
*43	Liner, O.D. Sealing . . . . .	1	963	Lockwasher . . . . .	6
*51	Gasket . . . . .	1			

\* Indicates parts in the Minor Overhaul Kit.

\*\* Indicates parts in the Major Overhaul Kit.

*(This Major Overhaul Kit also includes all parts in the Minor Overhaul Kit.)*

Optional Fitting supplied for Operational Checks.

## Output Housing Sub-Assembly

(Figure 10.04)

REF. No.	PART NAME	QTY.	REF. No.	PART NAME	QTY.
1	Output Shaft . . . . .	1	**45	Breather . . . . .	1
7	Bearing Retainer . . . . .	1	**46	Sight Gauge . . . . .	5
9	Output Housing . . . . .	1	63	Soc. Hd. Cap Screw . . . . .	1
14	Pipe Plug, Sq. Hd. . . . .	1	72	Pipe Plug . . . . .	2
*26	Ball Bearing . . . . .	1	122	Dowel Pin . . . . .	2
*28	Ball Bearing . . . . .	1	127	Lockwasher . . . . .	
*31	Oil Seal . . . . .	1	181	Key . . . . .	
**33	Locknut . . . . .	1	**195	Wear Sleeve . . . . .	

\* Indicates parts in the Minor Overhaul Kit.

\*\* Indicates parts in the Major Overhaul Kit.

*(This Major Overhaul Kit also includes all parts in the Minor Overhaul Kit.)*

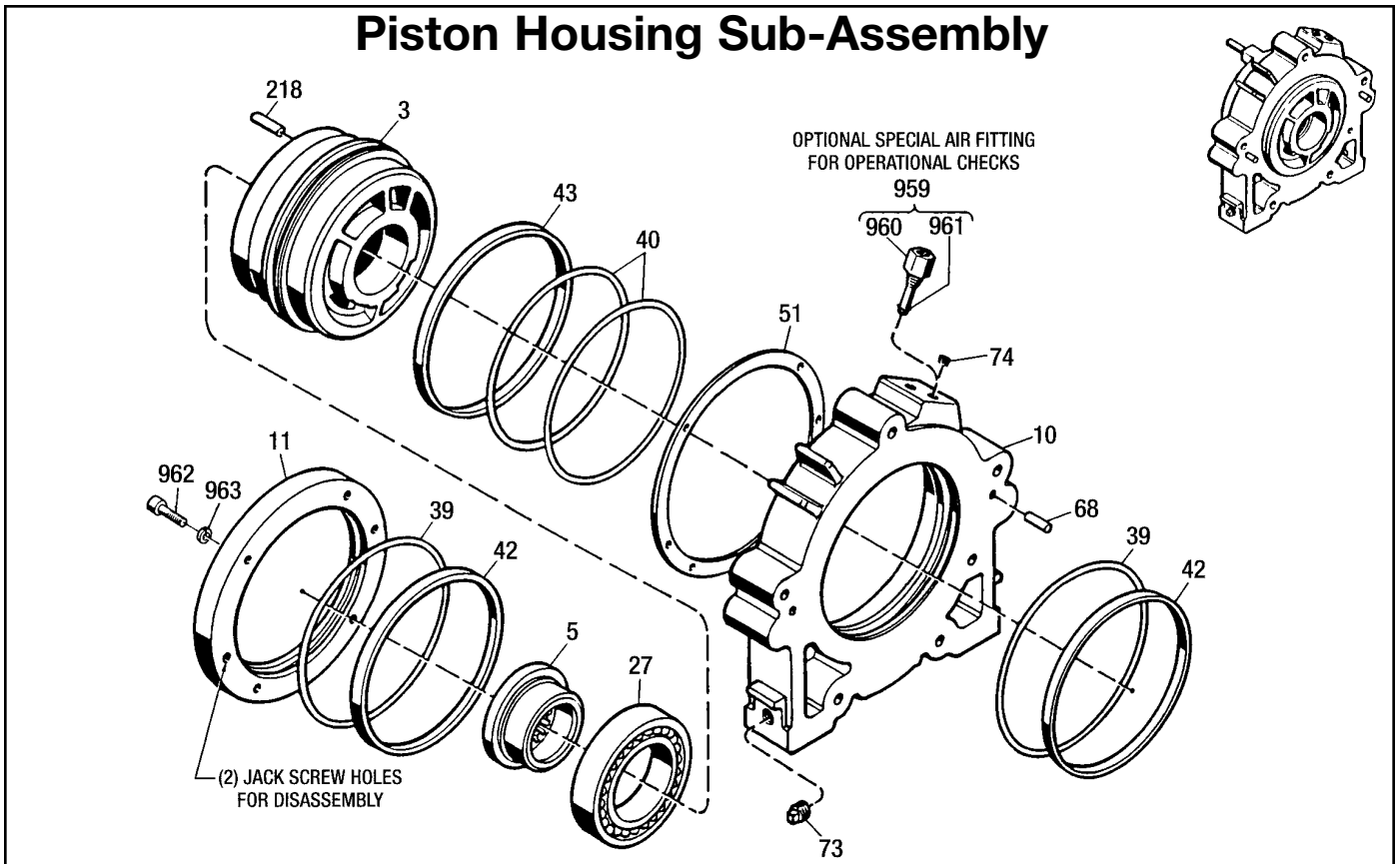

Figure 10.03 - Piston Housing Sub-Assembly

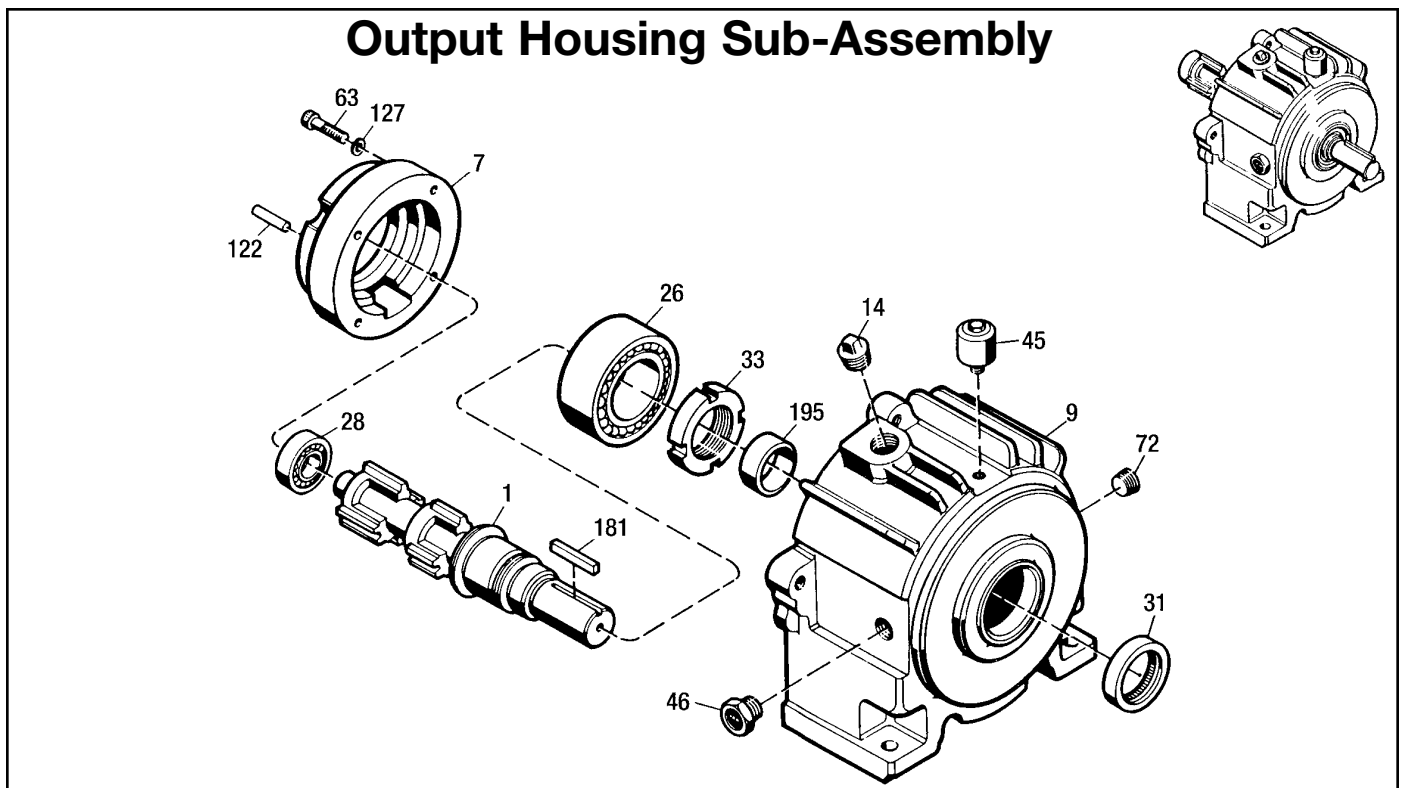

Figure 10.04 - Output Housing Sub-Assembly

## Manual Revision & Printing History

### *EL-02 Posidyne Clutch/Brake*

REVISION NUMBER	REVISION DATE <i>(Mo./Yr.)</i>	PRINTING DATE <i>(Mo./Yr.)</i>	REVISION/ACTION DESCRIPTION	REVISION INITIATED BY: <i>(Name)</i>	REVISION MADE BY: <i>(Name)</i>
502-EL-02-002	-----	11/97	Printed	-----	-----
502-EL-02-003	10/03	-----	Created complete digital file to create a PDF file for the web. Updated manual format. New cover and back. Added Warranty information. Expanded Operating Specifications in Section 2. Removed Detroit info. Added Revision History.	Brooks	Brooks

***FORCE CONTROL INDUSTRIES, INC.***

***Worldwide Leader in Oil Shear Technology.***

*Providing today's industries  
with Oil Shear Clutch and  
Brake Drives that delivers:  
Flexibility • Efficiency  
Endurance • Performance  
Dependability*

---

---

**“Built to Last - Guaranteed to Perform”**

---

---



***FORCE CONTROL INDUSTRIES, INC.***

**MAIN OFFICE**

P.O. Box 18366

Fairfield, Ohio 45018

3660 Dixie Highway

Fairfield, Ohio 45014

Tel: (513) 868-0900

Fax: (513) 868-2105

E-Mail: [info@forcecontrol.com](mailto:info@forcecontrol.com)

Web Site: [www.forcecontrol.com](http://www.forcecontrol.com)