

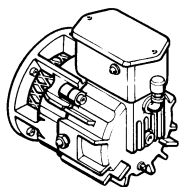

MSB2 "Quick Mount" MagnaShear Motor Brake INSTALLATION MANUAL

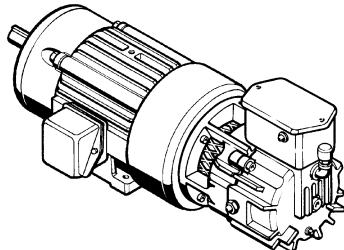

MagnaShear MSB2 Motor Brake



MODELS & SIZE

This Installation Manual covers the Installation Procedure for the MSB2 "Quick Mount" MagnaShear Electric Motor Brake and the MSB2 Assembled Electric Brake Motor (EBM).

MagnaShear MSB2 Motor Brake Furnished as an Assembled Electric Brake Motor (EBM).

DESCRIPTION & OPERATION

UNIT DESCRIPTION (See Figure 1)

The MSB2 "Quick Mount" MagnaShear Fully Electric Motor Brake with Oil Shear dependability mounts to the following NEMA standard motor frame sizes: 56, 143T, 145T, 182 and 184 (5.875" Dia. Bolt Circle). Spring set torque ratings range from 6 Lb. Ft. to 12 Lb. Ft.

A spring set brake stack is released when 120 VAC or 230 VAC power, depending on the model, is supplied to the MagnaShear Brake. Control logic is made simple by use of the motor starter auxiliary contactors. Back EMF effect from the motor windings is eliminated.

The units are ideal for a wide variety of applications including indexing tables, lifts, transfer conveyors, tap heads and other start/stop devices.

UNIT OPERATION (See Figure 1)

The cross section in Figure 1 shows the MSB2 MagnaShear Motor Brake in the Stopped position with the brake stack engaged. The MSB2 MagnaShear Motor Brake will default to this position when all power is lost.

To run the Drive Motor the Brake Coil is energized, pulling the Armature Plate Assembly away from the Brake Stack which allows the splined hub and drive motor to rotate independently from the motor brake.

To stop the Drive Motor the Brake Coil is de-energized. This allows the brake springs to push the Armature Plate Assembly against the Brake Stack, clamping it and stopping the splined hub and drive motor.

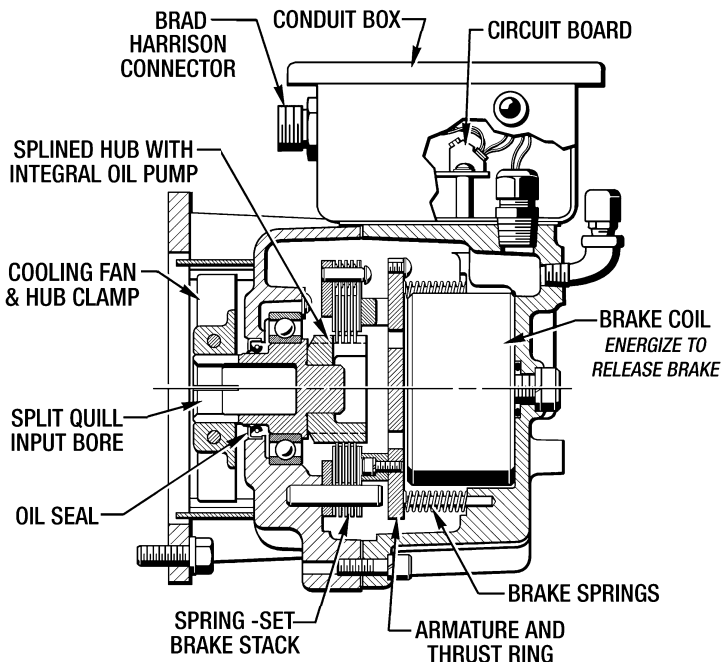
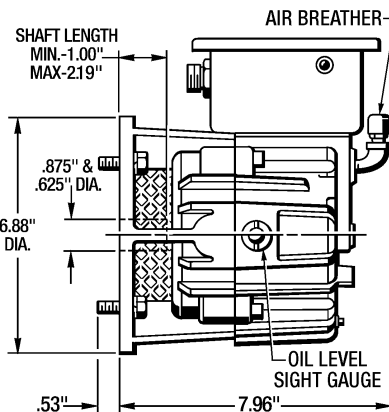
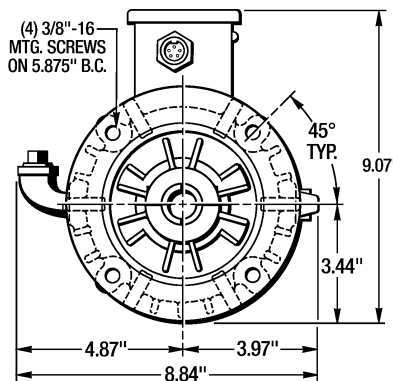

Figure 1 - Unit Description and Operation

DIMENSIONS

Horizontal Mounting



Vertical Mounting

ALL OTHER DIMENSIONS SAME AS HORIZONTAL MOUNTING ABOVE.

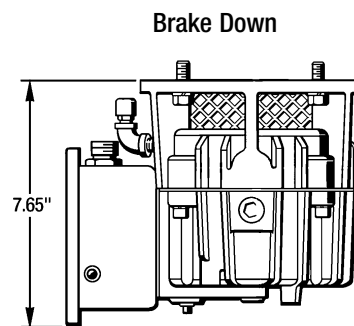
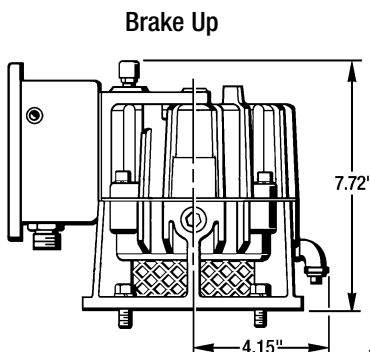

Figure 2 - Dimensions

Dimensions are subject to change without notice. Certified Installation Drawings are available upon request.

Force Control Industries, Inc.



MEX (55) 53 63 23 31 MTY (81) 83 54 10 18
QRO (442) 1 95 72 60 ventas@industrialmagza.com

MSB2 MagnaShear Motor Brake Specifications

BRAKE SIZE	AVAILABLE		No. OF SPRINGS	STATIC TORQUE (Lb. Ft.)	DYNAMIC TORQUE (Lb. Ft.)	MAX. KE per ENGMT. (Ft. Lbs.)	INERTIA (Lb. Ft. ²)	OIL CAP. (Ounces)	INPUT VOLTAGE (VAC)	INRUSH CURRENT .4 Sec. (Amps)	HOLDING CURRENT (Amps)	MAX. DUTY CYCLE	COIL RESISTANCE @ 20° C (Ohms)
	MNTG BC (Inches)	QUILL BORE (Inches)											
MSB2	5.875	.625	3	6	5	7975	0.011	28	115	2.5	.8	100%	47
		-----	4	8	7				-----	-----	-----		
		.875	6	12	10				230	1.3	.4		188

NOTE - The Input Voltage is either 115 or 230 VAC, depending on the Model.

Thermal Horsepower Rating

% DUTY	CYCLE RATE (Cpm)	AMBIENT TEMPERATURE	
		25° C	40° C
25%	2	.45	.17
	5	.45	.17
	10	.44	.16
50%	2	.37	.16
	5	.36	.15
	10	.35	.14
75%	2	.28	.13
	5	.27	.13
	10	.26	.12

NOTES: Thermal horse power ratings are based on 96° C maximum oil temperature and 1800 RPM motor.

% - Duty is percentage of time brake is released. (Coil is Energized.)

brake. The breather is taped to the motor shaft for shipment. Always check the oil level though, to see if the oil level is in the center of the Sight Gauge (#46). (See LUBRICATION on Page 4.)

B. MagnaShear Motor Brake

The standard **MSB2 MagnaShear Motor Brake** has been completely assembled and filled with fluid. The Air Breather (#45), (4) Mounting Bolts (#149) and (4) Lockwashers (#127) are usually shipped separate in a cloth bag tied to the brake unit.

A red plastic plug is installed in place of the Air Breather (#45) to prevent fluid from spilling out in shipment.

IMPORTANT - This red plastic plug must be removed and the Air Breather (#45) installed before operating your MSB2 MagnaShear Motor Brake.

Also check the fluid level to see if any has spilled out in transit. The fluid must be in the center of the Sight Gauge (#46). See LUBRICATION. Add fluid if necessary.

The Fan (#120) acts as a Quill Clamping Device to clamp the Hub (#2) to the motor shaft. This Fan will just be tightened enough to keep it in position on the Hub (#2). You will have to loosen the (2) Soc. Hd. Screws (#273) in the Fan (#120) to insert the motor shaft into the quill end of the Hub (#2).

IMPORTANT - Make sure the motor shaft and motor mounting surfaces are thoroughly cleaned before installing the Brake. DO NOT USE ANY LUBRICANT ON THE MOTOR SHAFT.

● VERIFYING MOTOR SPECIFICATIONS

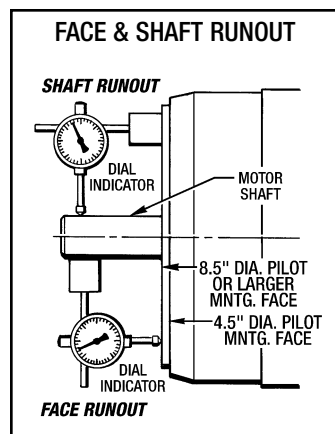

Figure 3 - Verifying Motor Specs.

The Motor Manufacturer's Specifications must be verified first to ensure the Motor Brake Oil Seal Reliability. (1) **Motor Shaft Runout** and (2) **Mounting Face Runout** need to be checked with a Dial Indicator as shown in Figure 3.

Maximum Allowable T.I.R. as per NEMA MG 1 Standard:

1. Motor Shaft Runout - .002"
2. Mntg. Face Runout - .004"

INSTALLATION

● IMPORTANT SAFETY PRECAUTIONS

The **MagnaShear Motor Brake** units described in this manual must not be installed in any manner except as specified and must not be operated at speeds, horsepower loads or temperatures other than those specified in this manual.

Failure to limit the operation of the drive to the conditions specified could damage the unit or damage interconnected equipment and void the Warranty.

WARNING

BEFORE INSTALLATION OR ATTEMPTING ANY REPAIRS TO THE MOTOR BRAKE, OPEN THE DISCONNECTS TO THE DRIVE MOTOR. LOCK IT OUT TO AVOID THE POSSIBILITY OF PERSONAL INJURY.

● RECEIVING THE MagnaShear MOTOR BRAKE

Check the brake for shortage or damage immediately after arrival. Prompt reporting to the carrier's agent, with notations made on the freight bill, will expedite satisfactory adjustment by the carrier.

A. Assembled Electric Brake Motor (EBM)

If your **MagnaShear Motor Brake** is shipped pre-assembled to a drive motor, it is filled with oil and ready to run except for installing the Air Breather (#45) and electrical wiring. (See Figures 6 and 7 for Electrical Wiring Diagram and Connector.)

NOTE: Before shipment, the Air Breather (#45) is removed and a pipe plug put in its place. This is done to prevent oil spillage during shipment. In most cases this will be a red plastic plug. This plug must be removed and the Breather (#45) installed to prevent damage to the

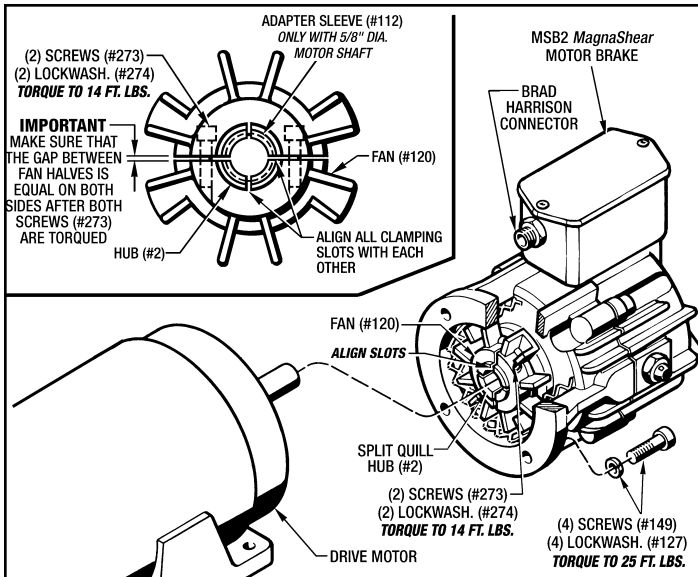

Figure 4 - Installing The MSB2 MagnaShear Motor Brake

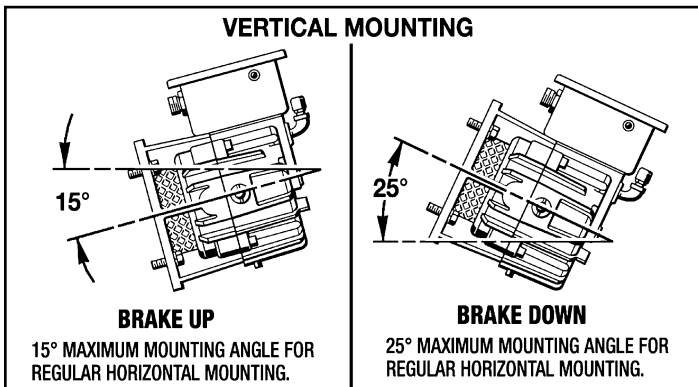

Figure 5 - Vertical Mounting Angles

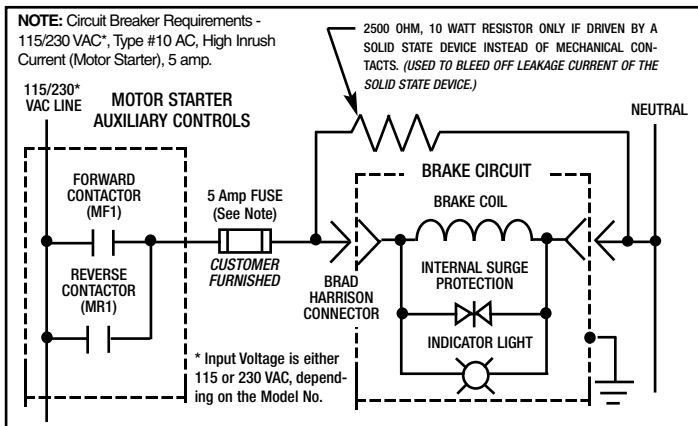

Figure 6 - Electrical Wiring Diagram

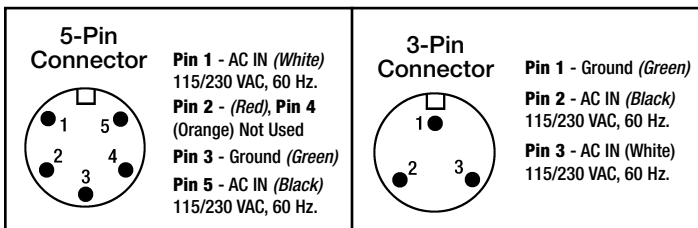

Figure 7 - Electrical Connector

● INSTALLING THE MagnaShear BRAKE

(See Figure 4)

Since your **MSB2 Motor Brake** has been built and shipped with your mounting position requirements, if for some reason you need to change the mounting position see *Figure 5* for Correct Mounting Angles. Drain the fluid out, move the Sight Gauge (#46), Air Breather (#45) and any other related fittings to conform to the appropriate mounting configuration shown in *Figure 8*. Refill with fluid as specified in the Lubrication Section.

1. If you have a 5/8" Dia. motor shaft then there will be a 5/8" Adapter Sleeve (#112) in the bore of the Hub (#2). Make sure the Quill Locking Slots are all aligned with each other as shown in *Figure 4*.

Also if you have a 7/8" Dia. motor shaft, you won't have the Adapter Sleeve (#112), but two of the Quill Clamping Slots in the Hub (#2) has to be aligned with the gaps in the Fan (#120) as shown in *Figure 4*.

2. Push the Fan (#120) back against the shoulder on the Hub (#2), then slide the Brake Unit onto the motor shaft as far as it will go. Align the (4) mounting holes with the motor and attach with (4) Mounting Bolts (#149) and (4) Lockwashers (#127). Finger tighten the (4) Bolts (#149) at this time. **Make sure the brake is snug against the motor face.**

3. Connect the electrical service to the Brad-Harrison Connector and actuate the brake coil to release the brake. (See *Figures 6 and 7*)

4. Evenly torque the (2) Screws (#273) in the Fan (#120) to **14 Ft. Lbs.** Make sure that both gaps in the Fan (#120) are equal as shown in *Figure 4*.

NOTE - This will correctly center the brake and allow the brake to "Float" into position.

5. Turn the motor shaft by hand to make sure the bearings turn freely. Adjust if necessary.

6. Evenly torque the (4) Mounting Bolts (#149) to **25 Ft. Lbs.**

● START-UP

Verify that the Brake Coil & Motor are wired correctly. Fuses are in place and the motor disconnect is turned on. Set-up preliminary settings on positioning switches to insure the brake will stop. "Bump" the Drive Motor to check for correct rotation. If the rotation is incorrect change two of the phase wires and recheck rotation. Verify that the Brake Coil Indicator Light on the Conduit Box is **ON** while the drive motor is running. **(The Indicator Light comes on bright for .4 Sec. and then dims after that.)**

Next, complete a cycle to insure that there are no interference problems within the system.

Set-up Position Switches as required.

FUNCTION	BRAKE COIL	
	On/Off	Ind. Light
RELEASE	ON	ON
BRAKING	OFF	OFF

LUBRICATION

● CHECKING THE OIL LEVEL

When the brake is installed and weekly thereafter, or until experience dictates otherwise, check the oil level. Always check the oil level with the brake at room temperature and while it is not running.

The **MSB2 MagnaShear Motor Brake** has an Oil Sight Gauge (#46) to visually check the fluid level. See *Figure 8* below for the location of this sight gauge.

It is located on the side of the End Housing (#9) for Horizontal and Vertical Up brakes and on the side of the Input Housing (#15) for Vertical Down brakes.

The oil level is to be at the center of this Sight Gauge (#46) for all models **with the drive motor turned off**.

● OPERATING TEMPERATURES

A. Ambient Temperature - The standard oil used in the **MSB2 MagnaShear Motor Brake** was designed to operate in an ambient temperature of 125° F Max. If the ambient temperature falls outside of this range please contact Force Control for specific recommendations on proper lubricant and oil seals.

B. Oil Sump Temperature - The maximum recommended oil sump temperature is 200° F.

● CHANGING THE OIL (See *Figure 8* below)

IMPORTANT - Always open the disconnects to the drive motor and lock them out before changing the oil.

Every three months completely drain the oil from the brake by removing the Drain Plug (#64). The Sight Gauge (#46) and Air Breather (#45) should also be removed and cleaned at this time.

The oil should be changed more frequently when used in harsh environments or high cyclic applications.

1. Remove Pipe Plug (#64) and drain out all the oil into a suitable container. Save or discard as conditions warrant. Replace the pipe plug when finished.
2. Remove the Pipe Plug (#62) and fill with fresh oil to the center of the sight Gauge (#46). Replace the pipe plug when finished.

CAUTION - Do not overfill the brake unit. Excess oil will cause the brake to over heat.

● TYPE OF OIL

Use only Mobil Automatic Transmission Fluid ATF-210 (Type "F") or Mobil Multi-Purpose Automatic Transmission Fluid for most drives.

Other fluids may be specified for special applications.

Always use the type of oil specified on the Name Plate.

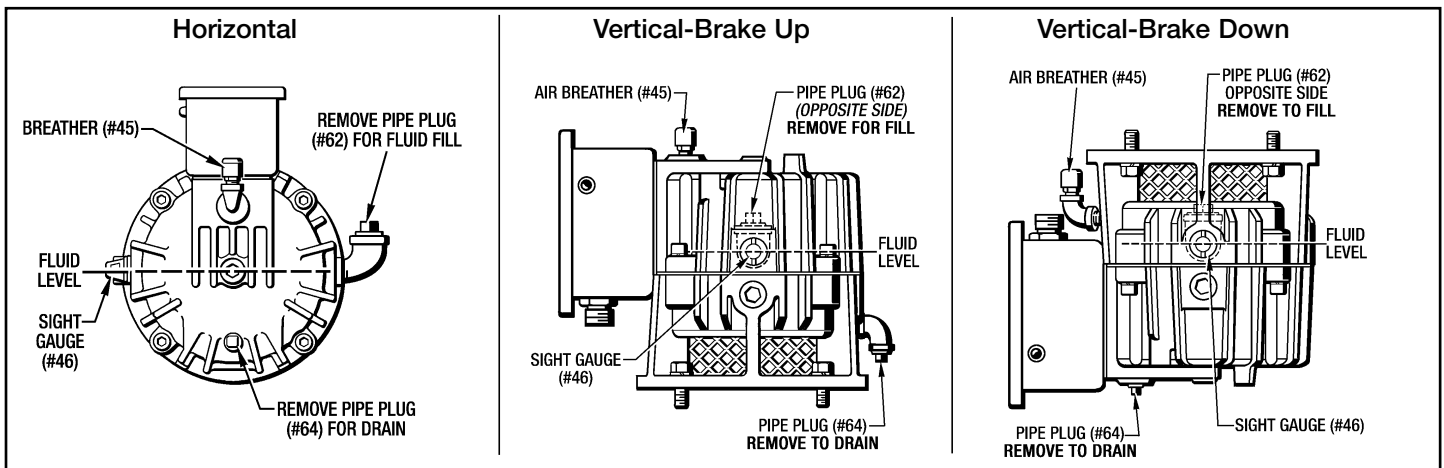

Figure 8 - Lubrication

FACTORY REBUILD SERVICE AND CATALOGS / SERVICE MANUALS

A Factory Rebuild Service is offered by Force Control Industries, Inc. Contact our service and sales department at Force Control for additional information.

A complete Service Manual can be downloaded and printed off of our web site. Go to: www.forcecontrol.com

All of our Catalogs and Service Manuals on the web site are in PDF format and will require Adobe Acrobat Reader 5.0 or later to open them. This Adobe Acrobat Reader 5.0 can be downloaded from our web site if you do not have it installed on your computer.



FORCE CONTROL INDUSTRIES, INC.

3660 Dixie Highway
Fairfield, Ohio 45014

Phone: 513-868-0900

Fax: 513-868-2105

E-Mail: info@forcecontrol.com

Web Site: www.forcecontrol.com