

502-MS-001-02

SERVICE MANUAL

FOR

MS-100 and MS-200

Magna  **Shear**™

FULLY ELECTRIC

TWO SPEED DRIVE

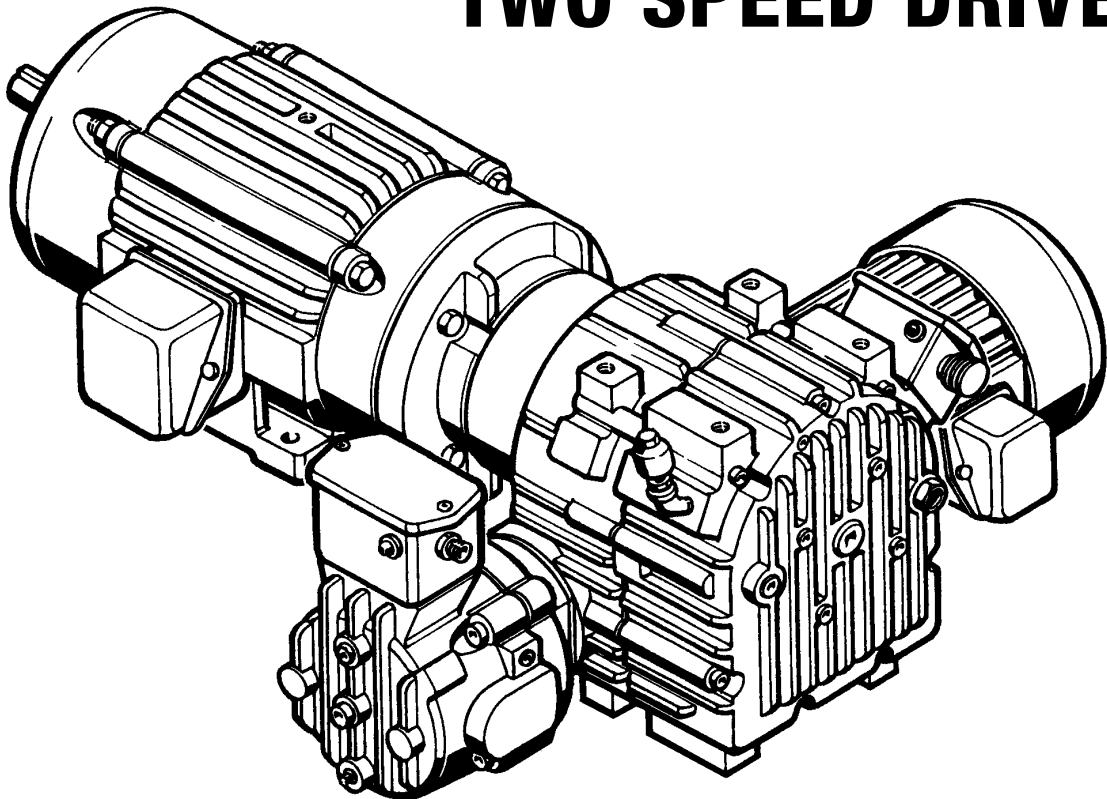

WARNING - Read this manual before any installation, maintenance or operation.



FORCE CONTROL INDUSTRIES, Inc.

MANUFACTURERS OF MECHANICAL AND
ELECTRICAL POWER TRANSMISSION EQUIPMENT



MEX (55) 53 63 23 31
QRO (442) 1 95 72 60

MTY (81) 83 54 10 18
ventas@industrialmagza.com

Limited Warranty

Force Control Industries, Inc. ("Force Control") warrants its products to be free from defects in material and workmanship under normal and proper use for a period of one year from the date of shipment. Any products purchased from Force Control that upon inspection at Force Control's factory prove to be defective as a result of normal use during the one year period will be repaired or replaced (at Force Controls' option) without any charge for parts or labor. This limited warranty shall be void in regard to (1) any product or part thereof which has been altered or repaired by a buyer without Force Control's previous written consent or (2) any product or part thereof that has been subjected to unusual electrical, physical or mechanical stress, or upon which the original identification marks have been removed or altered. Transportation charges for shipping any product or part thereof that the buyer claims is covered by this limited warranty shall be paid by the buyer. If Force Control determines that any product or part thereof should be repaired or replaced under the terms of this limited warranty it will pay for shipping the repaired or replaced product or part thereof back to the buyer. EXCEPT FOR THE EXPRESS WARRANTY SET OUT ABOVE, FORCE CONTROL DOES NOT GRANT ANY WARRANTIES EITHER EXPRESSED OR IMPLIED, INCLUDING IMPLIED WARRANTIES OF MERCHANTABILITY OR FITNESS FOR USE. The warranty obligation set forth above is in lieu of all obligations or liabilities of Force Control for any damages. Force Control specifically shall not be liable for any costs incurred by the buyer in disconnecting or re-installing any product or part thereof repaired or replaced under the limited warranty set out above. FORCE CONTROL EXPRESSLY EXCLUDES ALL LIABILITY FOR ANY INDIRECT OR CONSEQUENTIAL DAMAGES THE BUYER MAY SUSTAIN IN CONNECTION WITH THE DELIVERY, USE, OR PERFORMANCE OF FORCE CONTROL PRODUCTS. Under no circumstances shall any liability for which Force Control is held responsible exceed the selling price to the buyer of the Force Control products that are proven to be defective. This limited warranty may be modified only in writing signed by a duly authorized officer of the company. This limited warranty applies exclusively to Force Control products; warranties for motors and gear reducers and other component parts may be provided by their respective manufactures. Any legal action for breach of any Force Control warranty must be commenced within one year of the date on which the breach is or should have been discovered.

A Return Goods Authorization (RGA) number must be obtained from the factory and clearly marked on the outside of the package before any equipment will be accepted for warranty work. Force Control will pay the shipping costs of returning the owner parts that are covered by warranty.

Force Control believes that the information in this document is accurate. The document has been carefully reviewed for technical accuracy. In the event that technical or typographical errors exist, Force Control reserves the right to make changes to subsequent editions of this document without prior notice to holders of this edition. The reader should consult Force Control if errors are suspected. In no event shall Force Control be liable for any damages arising out of or related to this document or the information contained in it.

TABLE OF CONTENTS

Section 1 - DESCRIPTION and OPERATION

1-1	UNIT DESCRIPTION.....	1
	A. Main Motor	1
	B. <i>MagnaShear</i> Clutch/Brake	1
	C. Feed Motor.....	1
1-2	THE OIL SHEAR PRINCIPLE.....	2
1-3	OPERATION.....	2

Section 2 - SPECIFICATIONS

	Torque Specifications.....	4
	Performance Ratings.....	4
	Duty Cycle Specifications.....	5
	Recommended In-Line Fuse Sizes.....	5

Section 3 - INSTALLATION and START-UP

	IMPORTANT SAFETY PRECAUTIONS.....	6
3-1	RECEIVING THE <i>MagnaShear</i> DRIVE.....	6
3-2	MOUNTING THE <i>MagnaShear</i> DRIVE.....	6
3.3	WIRING SPECIFICATIONS.....	6
3-4	START-UP	6
	A. Checks before Start-Up.....	6
	B. Feed Motor Start-Up.....	6
	C. Main Motor Start-Up.....	6

Section 4 - LUBRICATION

4-1	CHECKING THE OIL LEVEL	8
4-2	OPERATING TEMPERATURES.....	8
	A. Ambient Temperatures.....	8
	B. Oil Sump Temperature	8
4-3	CHANGING THE OIL.....	8
4-4	TYPE OF OIL	8

Section 5 - OPERATIONAL CHECKS

5-1	CHECKING THE BRAKE OPERATION	9
5-2	CHECKING THE HIGH SPEED OPERATION AND INCHING SPEED OPERATION.....	9
	A. High Speed Operation (Clutch Coil)	9
	B. Inching Speed Operation (Brake Coil).....	9

Section 6 - TROUBLE SHOOTING

6-1	TROUBLE SHOOTING CHART	10
6-2	TROUBLE SHOOTING COILS.....	11

Section 7 - REPAIR and REPLACEMENT

7-1	GENERAL INFORMATION.....	12
7-2	PRIMARY CLUTCH STACK REPLACEMENT.....	12
	A. Disassembly Procedure	12
	B. Reassembly Procedure	12
7-3	CLUTCH COIL REPLACEMENT.....	13
	A. Disassembly Procedure	13
	B. Reassembly Procedure	13
7-4	REPLACING CLUTCH CIRCUIT BOARD.....	14
7-5	REPLACING SECONDARY BRAKE STACK.....	15
	A. Disassembly Procedure	15
	B. Reassembly Procedure	15
7-6	BRAKE COIL REPLACEMENT.....	16
	A. Disassembly Procedure	16
	B. Reassembly Procedure	16
7-7	REPLACING BRAKE CIRCUIT BOARD.....	16
7-8	REPLACING WORM SHAFT OIL SEAL (With C-Face Mounted Inching Motor).....	16
7-9	REPLACING WEAR SLEEVE (#68) (MS-200 With C-Face Mounted Inching Motor)	17
7-10	REPLACING WORM SHAFT OIL SEAL (MS-100 and MS-200 With Belt Drive).....	19
7-11	REPLACING WEAR SLEEVE (#69) (MS-200 With Belt Drive)	19

Section 8 - ILLUSTRATED PARTS LIST

8-1	GENERAL INFORMATION.....	21
8-2	DRIVE MOTORS.....	21
8-3	FACTORY REBUILD SERVICE.....	21
8-4	ORDERING REPLACEMENT PARTS.....	21
8-5	NAME PLATE AND MODEL NUMBER.....	22

REPAIR PARTS LISTS

Figure 8.1	MS-100 <i>MagnaShear</i> Drive.....	25
Figure 8.2	MS-200 <i>MagnaShear</i> Drive.....	27
Figure 8.3	Inching Speed Worm Shaft With C-Face Adapter.....	29
	Inching Speed Worm Shaft with Belt Drive.....	29
Figure 8.4	Secondary Brake Stack and Brake Ass'y.	31
Figure 8.5	Clutch Coil Junction Box and Circuit Board	32
Figure 8.6	Brake Coil Junction Box and Circuit Board	33

Section 1

DESCRIPTION and OPERATION

1-1 UNIT DESCRIPTION

The **MagnaShear** is a fully electric two speed oil shear clutch/brake. It can be operated in high speed, inching speed and spring-set braking modes.

High speed and inching speed modes are selected by energizing the appropriate electronically controlled coil. The spring-set braking mode is selected when both coils are de-energized allowing the springs to engage both disc stacks to stop the drive system.

The **MagnaShear** Two Speed Drive is built in a modular design for ease of assembly, disassembly and service. These modules include:

(A) Main Motor

(B) **MagnaShear** Clutch/ Brake

(C) Feed Motor.

A. Main Motor

The Main Motor is used to provide high speed motion to the driven machine. Standard U-Frame brakeless brake motors are typically used in most applications, while others are available for special needs. All motors supplied are Totally Enclosed Fan Cooled (T.E.F.C.) unless otherwise specified.

B. **MagnaShear** Clutch/Brake

The **MagnaShear** mounts directly to the main motor and is available in two sizes. The smaller **MS-100 MagnaShear** is capable of adapting to motor frame sizes ranging from 213 to 256U frames. The larger **MS-200 MagnaShear** is capable of adapting to motor frame sizes ranging from 284U thru 326U frames. Although U-frame motors are standard, other motor types may be used.

The **MagnaShear** contains a spring set secondary brake and a spring set primary clutch disc stack providing braking in the event of power loss. Both the secondary brake and primary clutch disc stack are electrically released and do not require any pneumatic plumbing or controls.

The **MagnaShear** contains an internal worm gear reducer to provide its inching speed output. This reducer shares the oil sump with the rest of the drive package making it easier to maintain. This reducer is available in a variety of ratios to adapt to many application requirements.

C. Feed Motor

The Feed Motor can be C-face Coupled as shown in Figure 1.1 or Belt Driven. (*Contact Force Control for authorized installation drawings for Belt Driven arrangements.*)

The inching speed output RPM can be varied per application by changing either the internal reducer or the Feed Motor belt ratio if this style is used. A standard NEMA foot mounted motor is provided if the belt drive option is used.

A standard NEMA C-face motor should be used if the C-face mounting is required. This motor mounts to the **MagnaShear** with a C-face Adapter. This adapter is available with a 4-1/2" pilot for the **MS-100 MagnaShear** and both a 4-1/2" and 8-1/2" pilot for the **MS-200 MagnaShear**. When using the C-face mount option the range of different low speeds is limited and may be varied only by changing the internal worm gear reducer ratio.

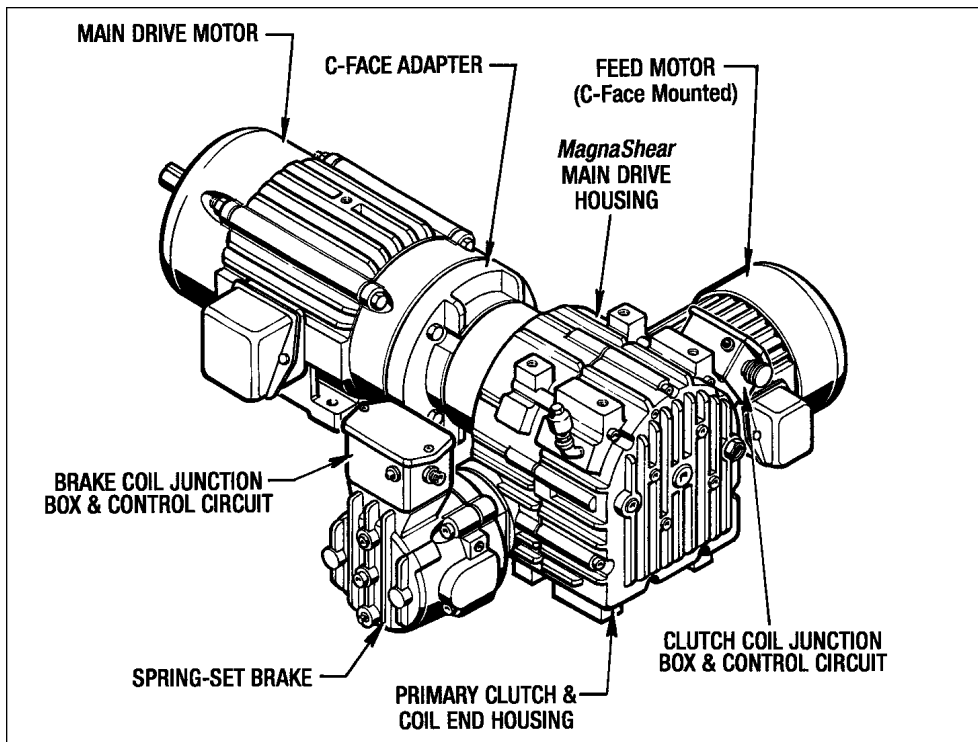

Figure 1.1 - MagnaShear Two Speed Drive with C-Face Mounted Feed Motor

FORCE CONTROL INDUSTRIES, INC.



MEX (55) 53 63 23 31 MTY (81) 83 54 10 18
QRO (442) 1 95 72 60 ventas@industrialmagza.com

1-2 THE OIL SHEAR PRINCIPLE

Conventional clutches and brakes depend on the friction between solid surfaces operating in air to transmit torque. Friction does the job but produces a great amount of heat and wear. The **MagnaShear Two Speed Drives** are *Oil Shear Drives*, with the friction surfaces operating in a constantly replenished film of oil. The oil molecules tend to cling to each other and to the friction surfaces. As moving and stationary elements are brought together, a thin but positive film of oil is maintained between them which is controlled by the clamping pressure and carefully designed grooves in the friction discs. Torque is transmitted from one element to the other through the viscous shear of the oil film. As long as there is relative motion between the elements, they are protected by the oil, thus greatly reducing wear. The replenished oil film also effectively transmits heat away from the friction elements.

1-3 OPERATION

The cross section in Figure 1.2 shows the **MagnaShear** in the off position with both the primary clutch and secondary brake stacks engaged. The **MagnaShear** will default to this position when all power is lost.

To run the **MagnaShear** in high speed mode, the clutch coil is energized pulling the clutch armature plate assembly away from the primary clutch stack. This releases the disk stack and allows the splined hub and main motor to rotate independently from the inching input assembly. To stop the Main Motor, the brake stack is left engaged and the clutch coil is de-energized. This allows the primary clutch springs to push the clutch armature plate assembly to clamp the primary clutch disc stack and stop the drive.

To run the **MagnaShear** in inching mode, the clutch coil is de-energized. The brake coil is energized to release the brake and allow the worm gear to turn freely. Torque is transmitted from the worm gear, to the worm wheel and thru the primary clutch stack since it is not released. The primary clutch stack transmits torque to the splined hub and thru the Main Motor.

When the brake coil is de-energized, the brake springs will force the brake armature plate to clamp the secondary brake stack causing the inching speed input to stop. Since the primary clutch stack is clamped, the splined hub and Main Motor will also be stopped.

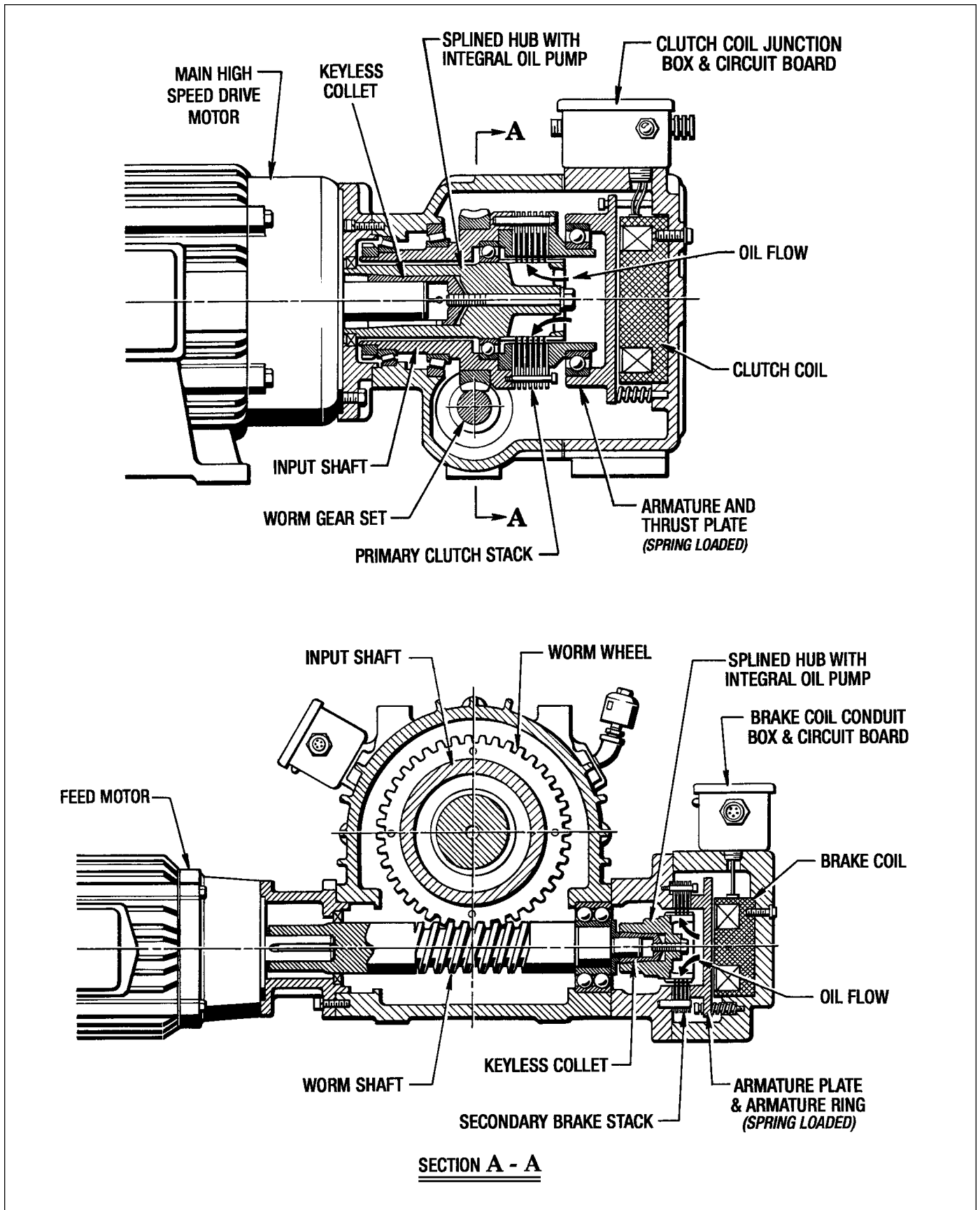

Figure 1.2 - MagnaShear Two Speed Drive Cross Section

Section 2 SPECIFICATIONS

MS-100 *MagnaShear* TORQUE SPECIFICATIONS

NUMBER OF SPRINGS	TORQUE (Ft./Lbs.)
2	21
4	42
6	63
8	84

MS-200 *MagnaShear* TORQUE SPECIFICATIONS

NUMBER OF SPRINGS	TORQUE (Ft./Lbs.)
2	50
4	100
6	150
8	200

PERFORMANCE RATINGS

<i>MagnaShear</i> SIZE	HP	RPM	DRIVE WK ² (Lb/Ft ²)	NO LOAD STARTS/MIN.
MS-100	2	1200	0.57	42
	3	1200	0.74	38
	5	1200	2.56	27
	7.5	1200	4.30	23
	3	1800	0.57	35
	5	1800	0.66	27
	7.5	1800	1.47	24
	10	1800	1.47	22
MS-200	10	1200	4.35	15
	15	1200	5.45	13
	20	1200	7.45	16
	15	1800	2.55	16
	20	1800	3.40	16
	25	1800	5.65	10
	30	1800	7.25	10

To determine the **Starts per Minute** capability of the *Magna Shear* when installed, use the following formula:

$$S/M1 = \frac{WK^2_D}{WK^2_D + WK^2_L} \times S/M$$

S/M1 = Starts per Minute capability of installed Drive.

WK²_D = Inertia of Magna Shear from above table.

WK²_L = Inertia of driven load reflected to *MagnaShear*.

S/M = No load starts per minute rating from above table.

MS-100 MagnaShear DUTY CYCLE SPECIFICATIONS

COIL	ELECTRICAL SPECIFICATIONS					
	MAX. DUTY CYCLE (Percent)	COIL RESISTANCE @ 70° F (Ohms)	INPUT VOLTAGE (Volts)	INRUSH CURRENT .4 Sec. (Amps)	HOLDING CURRENT (Amps)	MAXIMUM TORQUE (Ft./Lbs.)
PRIMARY CLUTCH	50%	23± 10% ----- 92 ± 10%	115 VAC ----- 230 VAC	5.5 ----- 2.8	.6 ----- .3	84
SECONDARY BRAKE	100%	47± 10% ----- 188 ± 10%	115 VAC ----- 230 VAC	2.5 ----- 1.3	.3 ----- .2	12

MS-200 MagnaShear DUTY CYCLE SPECIFICATIONS

COIL	ELECTRICAL SPECIFICATIONS					
	MAX. DUTY CYCLE (Percent)	COIL RESISTANCE @ 70° F (Ohms)	INPUT VOLTAGE (Volts)	INRUSH CURRENT .4 Sec. (Amps)	HOLDING CURRENT (Amps)	MAXIMUM TORQUE (Ft./Lbs.)
PRIMARY CLUTCH	50%	21.5 ± 10% ----- 86 ± 10%	115 VAC ----- 230 VAC	6 ----- 3	.6 ----- .3	200
SECONDARY BRAKE	100%	47± 10% ----- 188 ± 10%	115 VAC ----- 230 VAC	2.5 ----- 1.3	.3 ----- .2	28

RECOMMENDED IN-LINE FUSE SIZE

(Customer Supplied)

COIL	FUSE SIZE
PRIMARY CLUTCH	5 Amp
SECONDARY BRAKE	3 Amp

CIRCUIT BREAKER REQUIREMENTS:

1. **Primary Clutch** - 120 VAC Type#10 AC High Inrush Current (Motor Starter) 5 Amp.
2. **Secondary Brake** - 120 VAC Type#10 AC High Inrush Current (Motor Starter) 3 Amp.

Section 3

INSTALLATION and START-UP

IMPORTANT SAFETY PRECAUTIONS

The *MagnaShear Two Speed Drive* units described in this manual must not be installed in any manner except as specified and must not be operated at speeds, horsepower loads or temperatures other than those specified in this manual.

Failure to limit the operation of the drive to the conditions specified could damage the unit or damage interconnected equipment and void the Warranty.

Suitable guards for rotating shafts and couplings must be used at all times when operating equipment and is the responsibility of the customer.

WARNING

BEFORE INSTALLATION OR ATTEMPTING ANY REPAIRS TO THE DRIVE, OPEN THE DISCONNECTS TO BOTH MOTORS. LOCK THEM OUT TO AVOID THE POSSIBILITY OF PERSONAL INJURY.

3-1 RECEIVING THE *MagnaShear* DRIVE

Check the drive for shortage or damage immediately after arrival. Prompt reporting to the carrier's agent, with notations made on the freight bill, will expedite satisfactory adjustment by the carrier. When unloading or handling the drive always keep it upright. All drives are filled with oil and ready to run except for installing the Air Breather (#88).

NOTE:

Before shipment, the Air Breather (#88) is removed and a pipe plug put in its place. This is done to prevent oil spillage during shipment. In most cases this will be a red plastic plug. This plug must be removed and the Breather (#88) installed to prevent damage to the drive. The breather is taped to the drive for shipment.

3-2 MOUNTING THE *MagnaShear* DRIVE

1. The drive should be mounted on a firm level base or foundation. Use socket head cap screws or SAE grade 8 bolts to bolt the drive securely in place. Before tightening down the bolts, check alignment with driven machinery, then recheck after tightening.
2. If the Main Motor Shaft is to be directly coupled, use only a flexible coupling (with a horsepower service factor of 3 to 1) to take care of maximum torque requirements. Make sure the shafts to be coupled

are concentric within the coupling manufacturer's specifications. Check for horizontal, vertical or angular misalignment. Use shims as necessary to correct any misalignment.

If the motor drives a belt, coat shaft with heavy oil before installing pulley. Mount the pulley as close to the motor bearing as possible to minimize overhang load and align to run true.

CAUTION

Do not drive couplings or bushings on to the drive shaft. This may damage the bearings.

3. After the machinery has been in operation for a few hours, make sure that all mounting bolts are tight and recheck the alignment of all components.
4. After machinery has been in operation for 40 hours, check the mounting bolts and tighten if necessary.

3-3 WIRING SPECIFICATIONS

(See Figure 3.1)

3-4 START-UP

A. Checks before Start-Up

Verify that both the Clutch and Brake Coils are connected correctly. Check that both the Main and Feed Motors are wired correctly, fuses are in place and the disconnects are turned on. Set-up preliminary settings on positioning switches to insure the drive will stop.

B. Feed Motor Start-Up (Inching Speed)

"Bump" the Feed Motor to check for correct rotation. If the rotation is incorrect change two of the phase wires and recheck rotation. Verify that the Brake Coil Indicator Light on the junction box is **ON** while the Feed Motor is running.

Next, complete the cycle in inching speed to insure that there are no interference problems within the system.

Set-up inching speed position switches as required.

C. Main Motor Start-Up (High Speed)

"Bump" the Main Motor to check for correct rotation. If the rotation is incorrect, change two of the phase wires and recheck rotation. Verify that the Clutch Coil Indicator Light on the junction box is **ON** while the Main Motor is running.

Set-up high speed position switches as required.

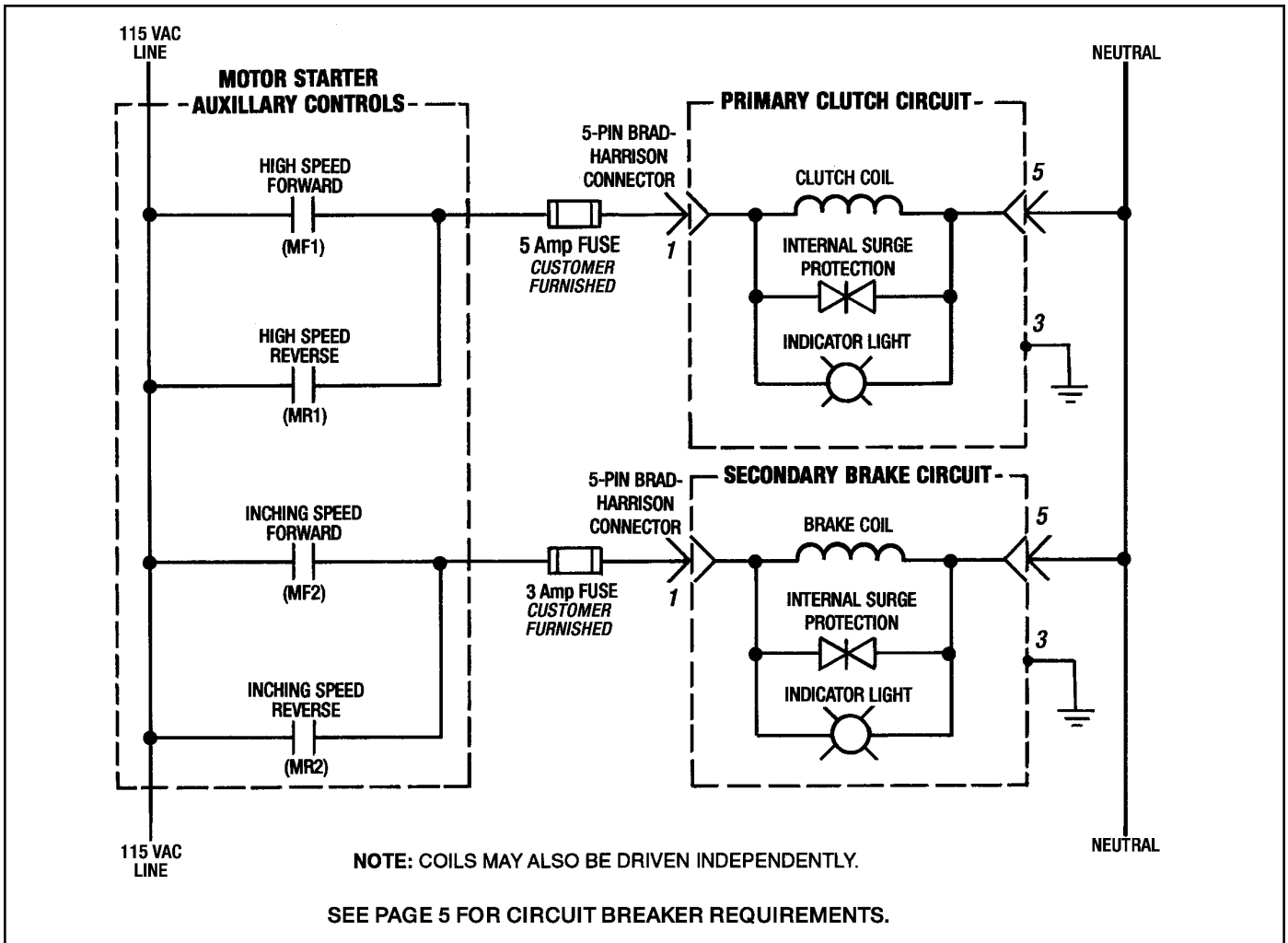

Figure 3.1 - Electrical Schematic

CONTROL LOGIC

Function	Motor Starter Energized	Clutch Coil Energized		Brake Coil Energized	
		On/Off	Ind. Light	On/Off	Ind. Light
High Speed Fwd.	MF1	ON	ON	OFF	OFF
High Speed Rev.	MR1	ON	ON	OFF	OFF
Inching Speed Fwd.	MF2	OFF	OFF	ON	ON
Inching Speed Rev.	MR2	OFF	OFF	ON	ON
Braking	None	OFF	OFF	OFF	OFF

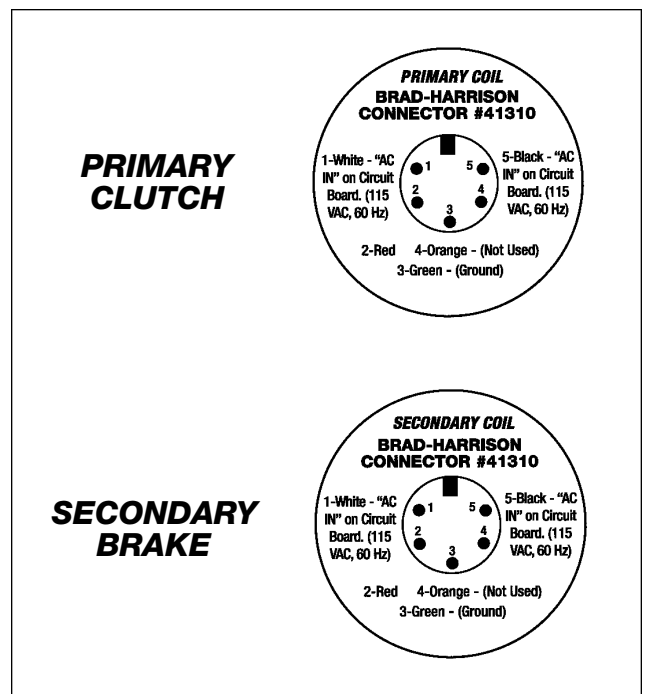

Figure 3.2 - Brad Harrison Connectors

Section 4 LUBRICATION

4-1 CHECKING THE OIL LEVEL

When the drive is installed and weekly thereafter, or until experience dictates otherwise, check the oil level. Always check the oil level with the drive at room temperature and while it is not running.

The *MagnaShear Two Speed Drive* has an oil sight gauge located at the end of the Clutch End Housing. (See Figure 4.1). The oil level is to be at the center of the sight gauge.

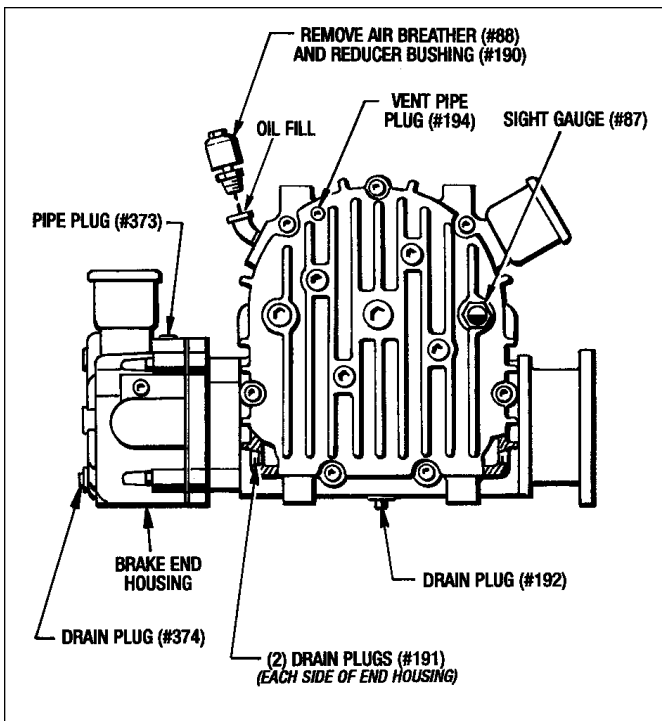

Figure 4.1 - Lubrication

4-2 OPERATING TEMPERATURES

A. Ambient Temperature

The standard oil used in the *MagnaShear* Drive was designed to operate between 40° F and 125°F. If the ambient temperature will fall outside of this range please contact Force Control Industries, Inc. for specific recommendations on proper lubricant and oil seals.

B. Oil Sump Temperature

The maximum recommended oil sump temperature is 200° F.

4-3 CHANGING THE OIL

IMPORTANT

Always open the disconnects to the drive motors before changing the oil.

Every three months completely drain the oil from the drive by removing Drain Plugs (#191), (#192) and (#374). If the Sight Gauge (#87) is dirty, it should also be removed and cleaned.

The oil should be changed more frequently when used in harsh environments or high cyclic applications.

Replace the Drain Plugs and Sight Gauge if they were removed. Remove the Air Breather (#88), Reducer Bushing (#190) from the End Housing, Pipe Plug (#373) from the top of the Brake End Housing, and the Vent Plug (#194) from the top of the Clutch End Housing.

Fill the unit with oil until the oil starts to come out the hole in the Brake End Housing. Replace the Pipe Plug (#373) at this time and continue filling until the oil is in the center of the Sight Gauge (#87).

IMPORTANT

It is very important that this Pipe Plug (#373) be removed when initially filling the drive unit with oil. This eliminates any air pockets in the brake section of the drive unit.

CAUTION

Do not overfill the drive unit. Excess oil will cause the drive to over heat.

Finally replace the Vent Pipe Plug (#194), Reducer Bushing (#190) and the Air Breather (#88).

4-4 TYPE OF OIL

Use only Mobil Automatic Transmission Fluid ATF-210 (Type "F") or Mobil Multi-Purpose Automatic Transmission Fluid for most drives.

Other fluids may be specified for special applications.

Always use the type of oil specified on the Name Plate.

Section 5 OPERATIONAL CHECKS

Make these Operational Checks with the *MagnaShear Drive Unit* shut down and completely assembled with both drive motors attached.

Provisions for manual operation checks must be made if the drive unit has been removed for service and repair. 120 VAC, 60 Hz. electrical service is required to energize the coils. (See Figure 5.1 below for the Test Set-Up)

Electrical Power is also necessary to “Bump” the Feed Motor.

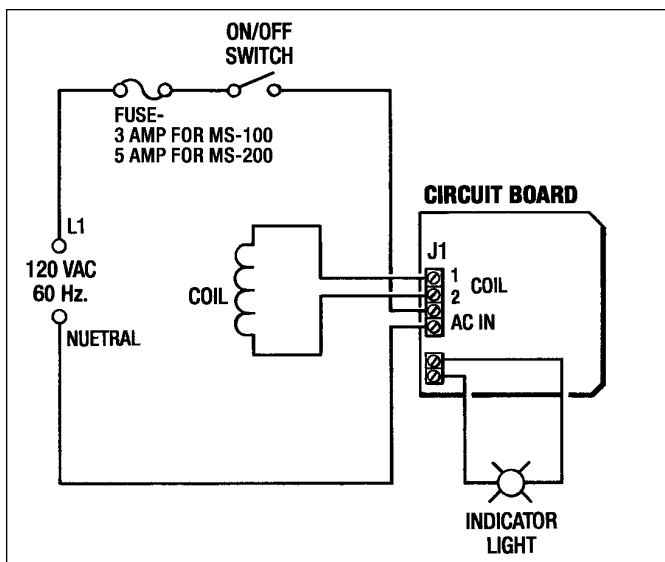

Figure 5.1 - Test Set-Up Electrical Schematic

5-1 CHECKING THE BRAKE OPERATION

To check the Brake Operation electrical power is not required to energize the coils since the *MagnaShear Drive* has a normally spring loaded brake when both coils are de-energized. Electrical power is only required for the Feed Motor.

“Bump” the Feed Motor and observe the Main Motor Output Shaft. If it turns, the Brake Stack may be worn and need to be replaced or there is insufficient spring pressure. (in either case, see Section 6 - Trouble Shooting.)

5-2 CHECKING THE HIGH SPEED OPERATION AND INCHING SPEED OPERATION

1. Remove the covers from both Junction Boxes (#405).
2. Disconnect the black and white power leads from the Brad-Harrison Cable Connector (# 416) to “AC In” on Terminal Strip J1. located on the Circuit Board.

A. High Speed Operation (Clutch Coil)

1. Connect the test power leads to “AC In” on J1. Turn the On/Off Switch to ON. The Power Indicator Light should come on.

CAUTION

Do not exceed the “Max. On Time” given in Section 2 SPECIFICATIONS on page 5. Exceeding this time could burn out the coil.

2. Manually turn the Main High Speed Motor Output Shaft. If the shaft turns then the Clutch Coil and Control Circuit is operating properly.

If it is not able to be turned, then the Clutch Coil or Circuit Board is not functioning properly. (See Section 6 - Trouble Shooting.)

B. Inching Speed Operation (Brake Coil)

1. Connect the test power leads to “AC In” on J1. Turn the On/Off Switch to ON. The Power Indicator Light should come on.

CAUTION

Do not exceed the “Max. On Time” given in Section 2 SPECIFICATIONS on page 5. Exceeding this time could burn out the coil.

2. “Bump” the Feed Drive Motor and observe the Main Drive Motor Shaft rotation. If the shaft turns then the Brake Coil and Control Circuit is operating properly.

If it does not turn, the Brake Coil or circuit board is not functioning properly and may need to be replaced. (See Section 6 - Trouble Shooting.)

Section 6 TROUBLE SHOOTING

6-1 TROUBLE SHOOTING CHART

PROBLEM	POSSIBLE CAUSE	REMEDY
1. Both Clutch and/or Brake fails to engage properly.	Electrical control circuit. Faulty <i>MagnaShear</i> circuit board. Worn friction surfaces.	Check control circuit. Replace circuit board. Check disc stack for wear and replace if necessary.
2. Both Clutch and/or Brake fails to release properly.	Electrical control circuit. Faulty <i>MagnaShear</i> circuit board. Faulty coil. Low voltage at coil.	Check control circuit. Replace circuit board. Replace coil. Check wire size and voltage.
3. Clutch torque too high.	Excessive spring force. Low oil level.	Contact Force Control. Check oil level and add oil.
4. Clutch torque too low	Inadequate spring force.	Contact Force Control.
5. Noise-High pitch whine	Clutch engaged with high speed motor running.	Check control circuit.
6. Excess vibration	Misaligned coupling. Mounted on poor foundation. Bad bearing.	Check alignment. Improve installation. Tighten mounting bolts. Replace bearing.
7. Drive overheats (200° F max.)	Clutch or brake fails to engage or disengage properly. Change in cycle rate or load. Improper oil level.	See #1 and #2 above. Contact Force Control. Check oil level. Add/Drain as req'd.
8. Oil leakage.	Bad oil seal Gaskets. Poor ventilation.	Disassemble and replace. Tighten all external screws. Remove breather and clean.
9. Clutch or brake does not repeat.	Electrical control circuit. Faulty <i>MagnaShear</i> circuit board. * Oil temperature change. Machine resistance changed.	Check control circuit. Replace circuit board. Check temperature. Lubricate bearings.

* For installations requiring precise starting and stopping, operating temperatures are important. Operating temperatures between 116° F and 165° F are recommended. If the oil is allowed to drop to ambient temperatures overnight, the clutch input shaft should be run for approximately 1/2 hour before operating the machinery.

6-2 TROUBLE SHOOTING COILS

A. Coil Resistance Test

Remove the cover from the Junction Box (#405) and disconnect the (2) Coil Leads from both terminals on the Terminal Strip J1 located on the Circuit Board (#400).

Hook-Up a Meg-Ohmmeter to both coil leads as shown in Figure 6.1. Set the Meg-Ohmmeter to "Ohm" range and test Resistance at 500 VDC.

The Resistance should read as follows:

Clutch Coil Resistance.....23 Ohms ± 10%

Brake Coil Resistance.....95 Ohms ± 10%

A reading outside of this range would indicate that the Coil is bad and needs to be replaced. See Section 7 for Coil Replacement.

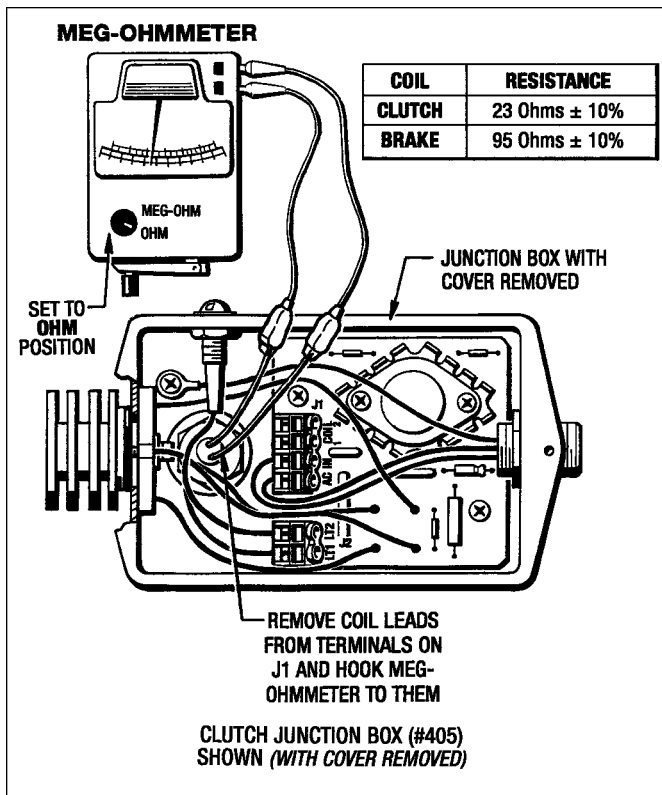

Figure 6.1 - Coil Resistance Testing

NOTE:

A Hi-Pot Tester can be used for this test but do not exceed 1250 VDC.

B. Coil Current Leakage Test

Remove the cover from the Junction Box (#405) and disconnect the (2) Coil Leads from both terminals on the Terminal Strip J1 located on the Circuit Board (#400).

Connect (1) alligator clip to both Coil Leads and the other one to Chassis Ground. (See Figure 6.2)

A reading of **10 Meg-Ohms or greater** indicates that the Coil is fine and does not need to be replaced. Anything much less would indicate that there is a short to ground and the Coil would need to be replaced. See Section 7 for Coil Replacement.

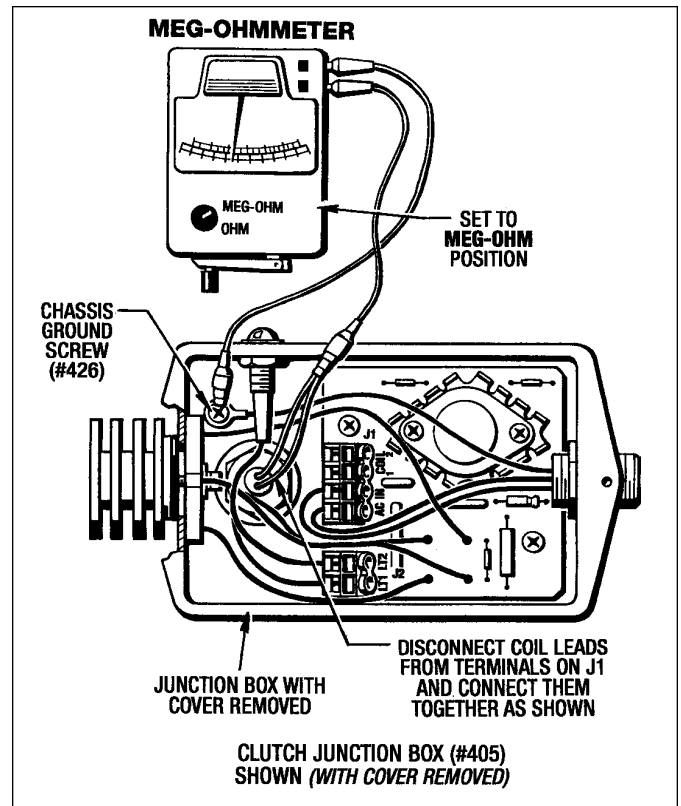

Figure 6.2 - Coil Current Leakage Testing

NOTE:

A Hi-Pot Tester can be used for this test but do not exceed 1250 VDC.

Section 7

REPAIR and REPLACEMENT

7-1 GENERAL INFORMATION

Because of the close tolerances that have to be maintained in the *MagnaShear* Drive, it is recommended that any repairs other than what is covered in this manual be done in our factory. Please contact Force Control Industries, Inc. Service and Sales Department for authorization and shipping instructions. Also see Section 8-3 for additional information on Force Control's Factory Rebuild Service.

An overhead hoist and soft sling is recommended to be used in removing any heavy parts.

WARNING

Shut-Off and Lock-Out all electrical power before attempting to make any repairs to the drive unit.

7-2 PRIMARY CLUTCH STACK REPLACEMENT

(See Figure 8.1 for MS-100 and Figure 8.2 for MS-200)

A. Disassembly Procedure

1. Drain the oil from the complete unit as specified in **Section 4-3 Changing The Oil**. Save or discard as conditions warrant.
2. Disconnect the Brad-Harrison Cable from the Junction Box (#405).
3. Attach (2) eyebolts to the top of the End Housing (#31) and support it with an overhead crane and sling.
4. Remove the (7) Screws (#144) and (7) Lockwashers (#174) and pull the End Housing Assembly away from the Main Housing Assembly (#15).

5. Remove and discard Gasket (#45).
6. The Clutch Stack Assembly (#36) can now be removed from the Main Drive Assembly by unscrewing the (4) Shoulder Bolts that mounts the Drive Plates to the Input Shaft and sliding it off the spline Hub (#2).
7. Install a new Clutch Stack Assembly (#36) onto the Hub spline and the Input Shaft Drive Pins (#91). Push it on as far as it will go and tighten the (4) Shoulder Bolts.

NOTE:

Make sure the spline teeth of the friction discs in the Clutch Stack Assembly (#36) are all aligned with each other so they will slide onto the Hub spline.

B. Reassembly Procedure

1. If the Clutch Stack is the only part that has to be replaced, then reassemble the End Housing Assembly back on the Main Drive Assembly.
2. First place a new Gasket (#45) onto the mounting face of the Main Housing (#15). **Do not use any gasket sealant on this gasket.**
3. Guide the End Housing Assembly onto Dowel Pins (#14) and attach with the (7) Lockwashers (#174) and (7) Screws (#144). **Torque to 37 Ft. Lbs.**
4. Replace Drain Plug (#191) and refill the unit with the correct oil to the center of the Sight Gauge (#87). **(See Section 4 - Lubrication)**

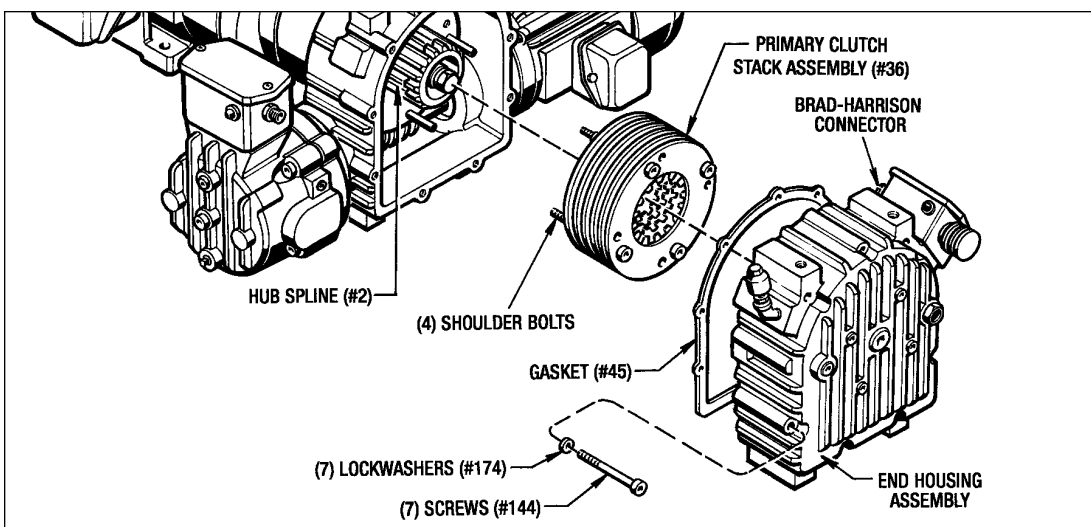

Figure 7.1 - Replacing Clutch Stack

7-3 CLUTCH COIL REPLACEMENT

(See Figures 8.1 and 8.5 for MS-100; Figures 8.2 and 8.5 for MS-200)

A. Disassembly Procedure

Remove the End Housing assembly with the same procedure as described in the previous Section 7-2, Steps 1 through 5. (See Figure 7.1)

- Remove the cover from the Junction Box (#405).
- Disconnect the coil leads from the Terminal Strip J1, located on the Circuit Board (#400) and remove the compression nut from the Electrical Fitting (#415). (See Figures 7.2 and 7.3)

- Lift and pull the Clutch Coil (#35) out of the End Housing.

NOTE: The (2) coil leads are fairly difficult to pull out of the Electrical Fitting (#415) because of the rubber seal, so pry the rubber seal out of the fitting and pull it off of the coil leads and save for reassembly. (See Figure 7.3)

B. Reassembly Procedure

- First set the End Housing upright then place a new Primary Coil (#35) into place while pushing the coil leads up through the threaded part of the Electrical Fitting (#415).

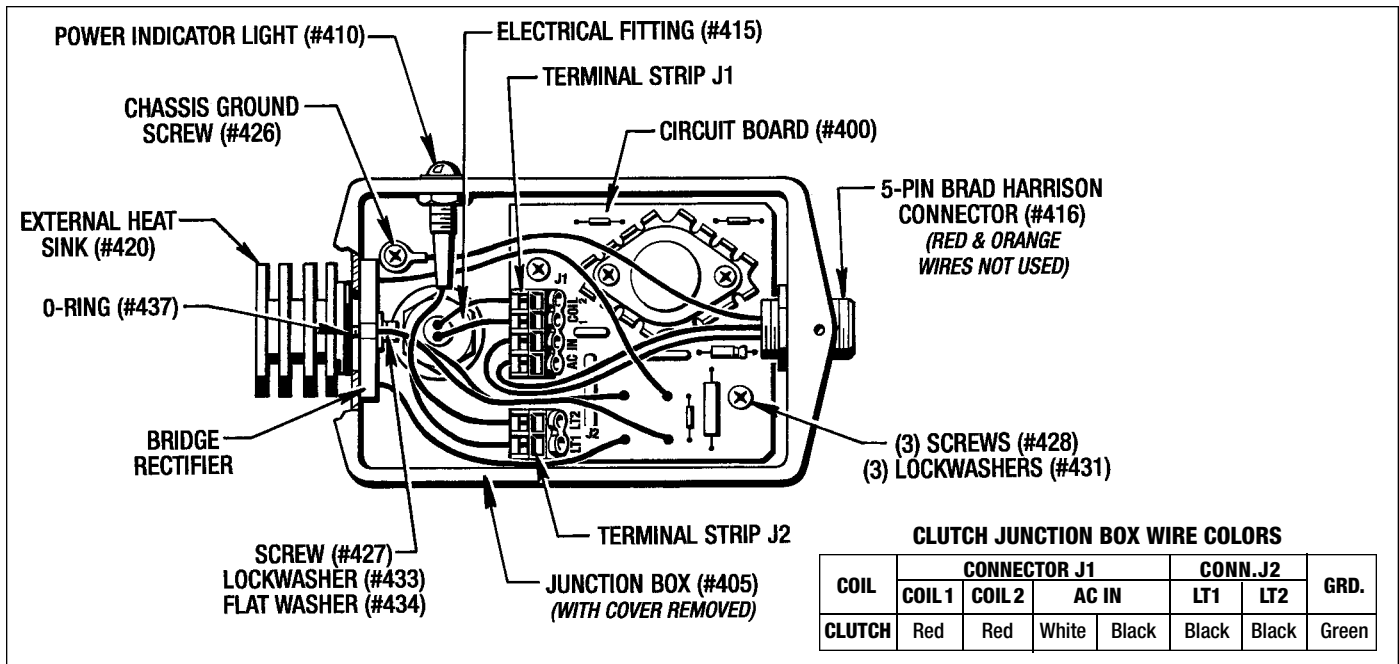

Figure 7.2 - Clutch Junction Box With Cover Removed

- Take the (4) Screws (#180) and (4) Dyna-Seal Washers (#177) out of the End Housing (#31).

Also remove the Sight Gauge (#87) from the end housing so it won't get damaged during Reassembly.

- Turn the End Housing with the Thrust Plate (#19) in an Up position.
- Loosen and remove the (4) Shoulder Bolts (#247) that holds the Armature (#32) in place.

CAUTION: This Armature (#32) is under spring pressure, so back the (4) Shoulder Bolts (#247) out carefully and evenly to release the spring pressure.

- Note the position of the Springs (#83) and make a sketch of the correct position of the springs. This will help at reassembly

- Assemble (4) Dyna-Seal Washers (#177) and (4) Screws (#180), then apply Blue Loctite to screw threads.
- Align mounting holes of End Housing (#31) and Clutch Coil (#35) so leads of coil are as close to the Electrical Fitting (#415) as possible. Attach Coil with the (4) Screws and (4) Dyna-Seal Washers from Step #2 and Torque to specified Torque:

(MS-100) 25 Ft. Lbs

(MS-200) 60 Ft. Lbs.

CAUTION

Do not over tighten these screws. The Dyna-Seal Washers could be damaged.

- Place the rubber seal on the coil leads and pull the wires through, taking up all the slack in the wires. Seat the rubber seal into the threaded part of the Electrical Fitting (#415). Tighten down the compression nut. (See Figure 7.3)

5. Turn the End Housing (#31) over with the Clutch Coil facing up.
6. According to your previous sketch place the correct number of Springs (#83) into their original position.
7. Place the Thrust Plate and Armature Sub-Assembly in place over the springs and coil. Make sure the Springs are in position with the Shoulder Bolt Holes in the Armature. Apply Blue Loctite to the threads of the (4) Shoulder Bolts (#247). Insert them into the Armature (#32) and tighten with a T-Handle Allen Wrench. (See Figure 7.4)

NOTE

The Shoulder Bolts (#247) for the MS-100 are not long enough to screw into the End Housing so the assembly must be placed into an arbor press to compress the springs enough. It is not necessary to do this with the MS-200.

8. Reinstall the Sight Gauge (#87) and the Drain Plug (#191) into End Housing (#31).
9. Re-attach the coil leads to J1 on the Circuit Board (#400) and replace the junction box cover.
10. Place a new Gasket (#45) on to the Main Housing. **Do not use any gasket sealant on this gasket.**
11. With an overhead crane and sling guide the End Housing Assembly into place and bolt with (7) Lockwashers (#174) and (7) Screws (#144). **Torque to 37 Ft. Lbs.**

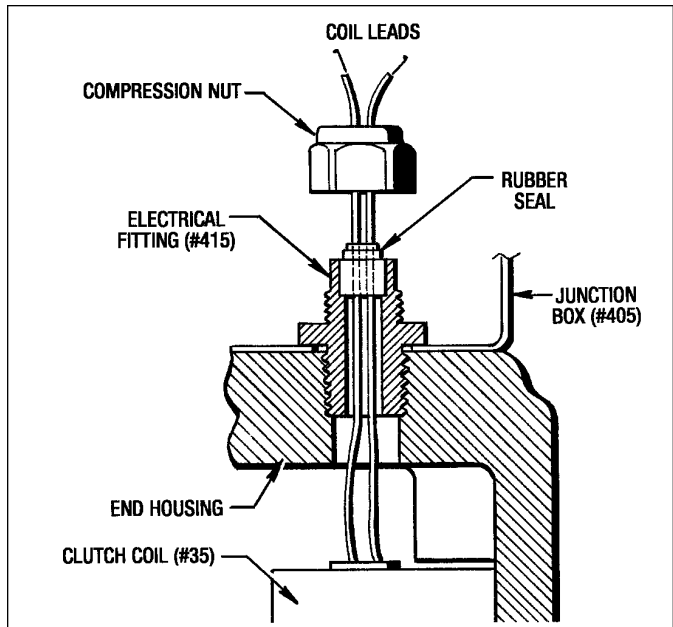

Figure 7.3 - Installing Coil Wires

12. Fill the Drive Unit with fresh oil to the center of the sight gauge. **See Section 4 - Lubrication.**

7-4 REPLACING CLUTCH CIRCUIT BOARD (#400)

(See Figure 7.2)

1. Take the cover off of the Junction Box (#405).
2. Disconnect all of the wires from Terminal Strips J1 and J2 on the Circuit Board (#400).

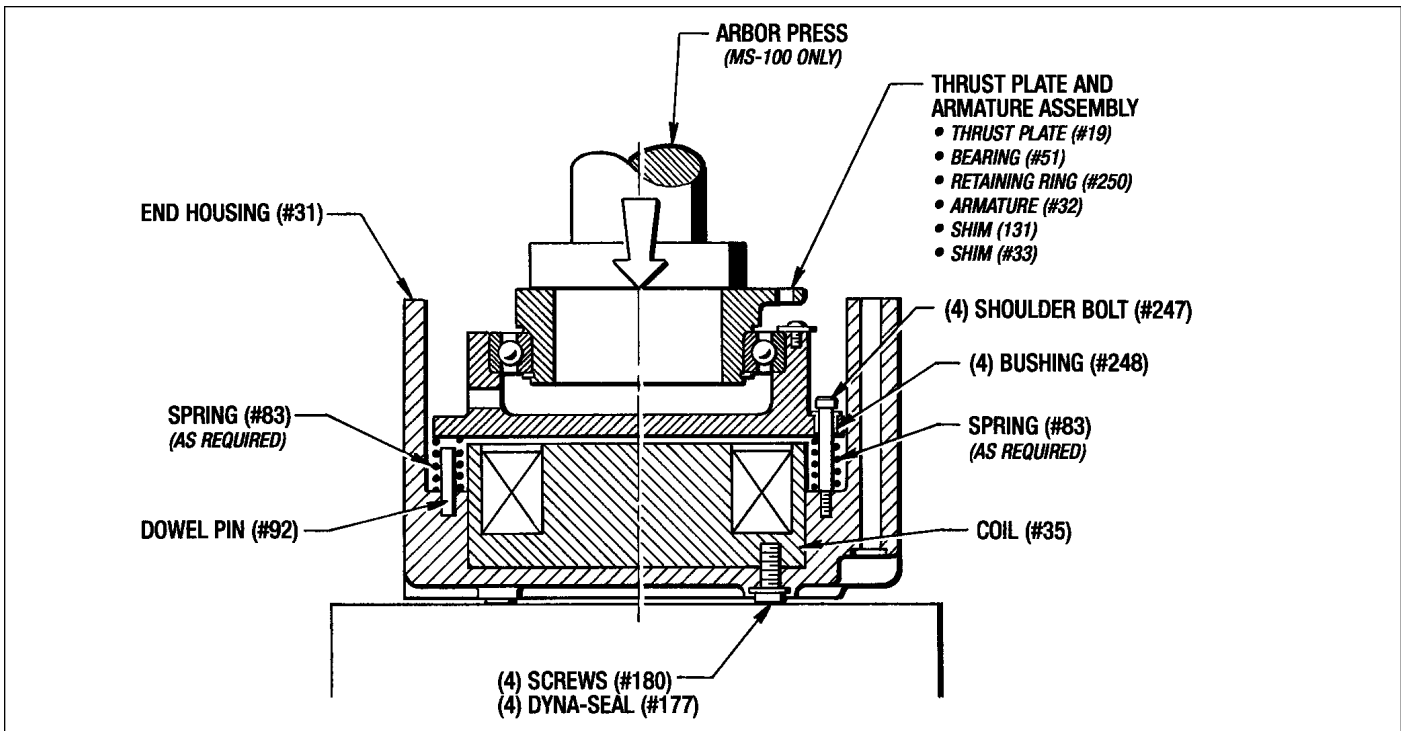

Figure 7.4 - Armature Reassembly

3. Remove the Screw (#427), Lockwasher (#433) and Flat Washer (#434) that holds the Bridge Rectifier and External Heat Sink (#420) to the Junction Box (#405). Remove the External Heat Sink (#420) and the O-Ring (#437) and save for re-assembly.
4. Remove the (3) Screws (#428) and (3) Lockwashers (#431).
5. Take the old Circuit Board (#400) off and replace it with a new one.
6. Re-attach with (3) Screws (#428), (3) Lockwashers (#431) and re-connect electrical wires to Terminal Strips J1 and J2.
7. Place the O-Ring (#437) back on the External Heat Sink (#420) and re-attach it with the Bridge Rectifier back to the Junction Box (#405) with the Screw (#427), Lockwasher (#433) and Flat Washer (#434). Replace the junction box cover.

7-5 REPLACING SECONDARY BRAKE STACK

(See Figure 8.4)

A. Disassembly Procedure

(See Figure 7.5)

1. Drain the oil from the complete unit as specified in **Section 4-3 Changing The Oil**. Save or discard the oil as conditions warrant.
2. Disconnect the 5-Pin Brad-Harrison Cable from the Conduit Box (#405).
3. Remove the (6) Screws (#316) and the (6) Lockwashers (#320) and pull the Brake End Housing (#309) away from the Brake Stack Assembly.

4. Remove and discard Gasket (#321).
5. The Brake Stack Assembly (#337) can now be removed by unscrewing the (4) Shoulder Bolts that bolts the Drive Plates to the Adapter (#308). Pull the Brake Stack Assembly off of the Hub spline (#302).
6. Install a new Brake Stack Assembly (#337) onto the Hub spline (#302) and the (4) Dowel Pins (#357). Push it on as far as it will go and tighten the (4) Shoulder Bolts.

NOTE - Make sure the spline teeth in the Friction Discs are aligned with each other so they will slide on to the Hub spline.

B. Reassembly Procedure

(See Figure 7.5)

1. If the Brake Stack is the only part that has to be replaced then reassemble the Brake End Housing Assembly back on to the Main Housing Assembly.
2. First place a new Gasket (#321) on to the mounting face of Adapter (#308). **Do not use any gasket sealant on this gasket.**

3. Attach the Brake End Housing Assembly with the (6) Lockwashers (#320) and (6) Screws (#316). **Torque Screws as specified:**

MS-100 14 Ft. Lbs.

MS-200 25 Ft. Lbs.

4. Replace Drain Plug (#191) and fill with correct oil to the center of the sight gauge. **(See Section 4 - Lubrication.)**

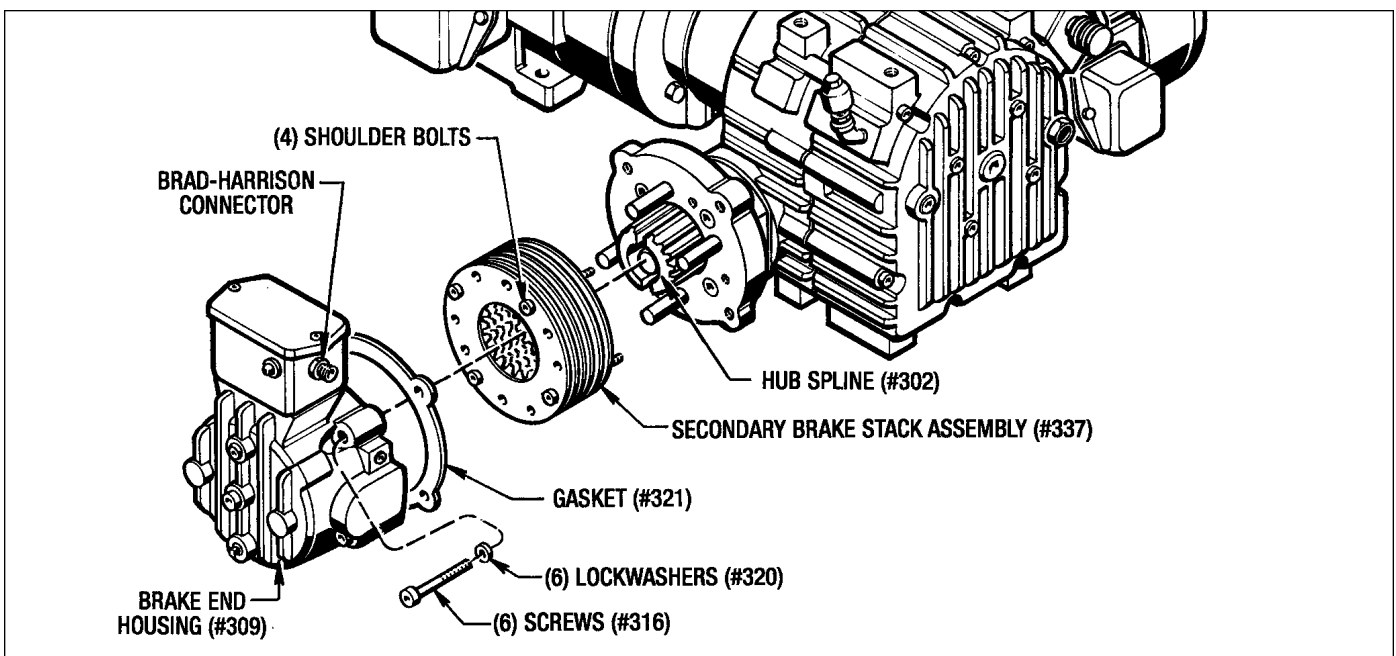

Figure 7.5 - Replacing Brake Stack

7-6 BRAKE COIL REPLACEMENT

(See Figures 8.4 and 8.6 for MS-100 and MS-200)

A. Disassembly Procedure

Remove the Brake End Housing assembly with the same procedure as described in the previous **Section 7-5, Steps 1 through 4.** (See Figure 7.5)

5. Remove the cover from the Junction Box (#405).
6. Disconnect the coil leads from the Terminal Strip J1, located on the Circuit Board (#400) and remove the compression nut from the Electrical Fitting (#415). (See Figure 7.6)
7. Take the (4) Screws (#377) and (4) Dyna-Seal Washers (#378) out of the End Housing (#309).
8. Turn the End Housing over with the Armature Ring (#333) in an up position.
9. Loosen and remove the (2) Shoulder Bolts (#347) that holds the Armature Plate (#332) in place.

CAUTION: This Armature Plate (#332) is under spring pressure, so back the (2) Shoulder Bolts (#347) out carefully and evenly to release the spring pressure.

11. Remove the (6) Springs (#336).
12. Lift and pull the Brake Coil (#335) out of the End Housing (#309).

NOTE

The (2) coil leads are fairly difficult to pull out of the Electrical Fitting (#415) because of the rubber seal, so pry the rubber seal out of the fitting and pull it off of the coil leads and save for reassembly. (See Figure 7.3)

B. Reassembly Procedure

1. First set the Brake End Housing (#309) upright.
2. Assemble the (4) Dyna-Seal Washers (#378) and the (4) Screws (#377). Apply Blue Loctite to the screw threads.
3. Set a new Brake Coil (#335) into the Brake End Housing (#309) so the coil leads are as close to the Electrical Fitting (#415) as possible. Push the electrical coil leads up through the threaded part of the fitting.
4. Attach the Brake Coil (#335) with the (4) Dyna-Seal Washers (#378) and (4) Screws (#377) prepared in Step #2. **Torque to Specified Torque:**

(MS-100) 7 Ft. Lbs. (MS-200) 14 Ft. Lbs.

CAUTION: Do not over tighten these Screws. The Dyna-Seal Washers could be damaged.

5. Place the rubber seal on the coil leads and pull the wires through, taking up all the slack in the wires.

Seat the rubber seal into the threaded part of the Electrical Fitting (#415). Tighten down the compression nut. (See Figure 7.6)

6. Turn the Brake End Housing over with the Brake Coil facing up.
7. Place the (6) Springs (#336) into their original position. **NOTE:** All (6) springs will go into the spring pockets. Two of them will be aligned with the (2) tapped holes for the (2) Shoulder Bolts (#347).
8. Place the Armature Plate (#332) and Armature Ring (#333) Sub-Assembly in place over the springs and coil. Apply Blue Loctite to the threads of the (2) Shoulder Bolts (#347). Insert them into the Armature Plate (#332) and tighten evenly with a T-Handle Allen Wrench.
9. Reattach the coil leads to J1 on the Circuit Board (#400) and replace the Junction Box Cover (#405).
10. Place a new Gasket (#321) on to the Brake End Housing.
Do not use any gasket sealant on this gasket.
11. Attach the Brake End Housing (#309) to the Adapter (#308) with the (4) Screws (#316) and the (4) Lockwashers (#320). **Torque as specified:**
(MS-100) 14 Ft. Lbs. (MS-200) 25 Ft. Lbs.
12. Reinstall the Sight Gauge (#87) and the Drain Plug (#191) back into the End Housing (#31).
13. Fill the Drive Unit with fresh oil to the center of the sight gauge. **(See Section 4 - Lubrication.)**

7-7 REPLACING BRAKE CIRCUIT BOARD (#400)

(See Figure 7.6)

The Brake Circuit Board is basically the same as the Clutch Circuit Board except it does not use an External Heat Sink (#420). The Replacement procedure is as follows:

1. Take the cover off the Junction Box (#405).
2. Disconnect all the wires from Terminal Strips J1 and J2 on the Circuit Board (#400).
3. Remove the (3) Screws (#428) and (3) Lockwashers (#431) that holds the Circuit Board (#400) to the stand-offs.
4. Take the old Circuit Board (#400) off and replace it with a new one.
5. Re-attach the new Circuit Board (#400) with the (3) Screws (#428) and (3) Lockwashers (#431). Reconnect the wires to Terminal Strips J1 and J2. Replace the cover on the Junction Box (#405).

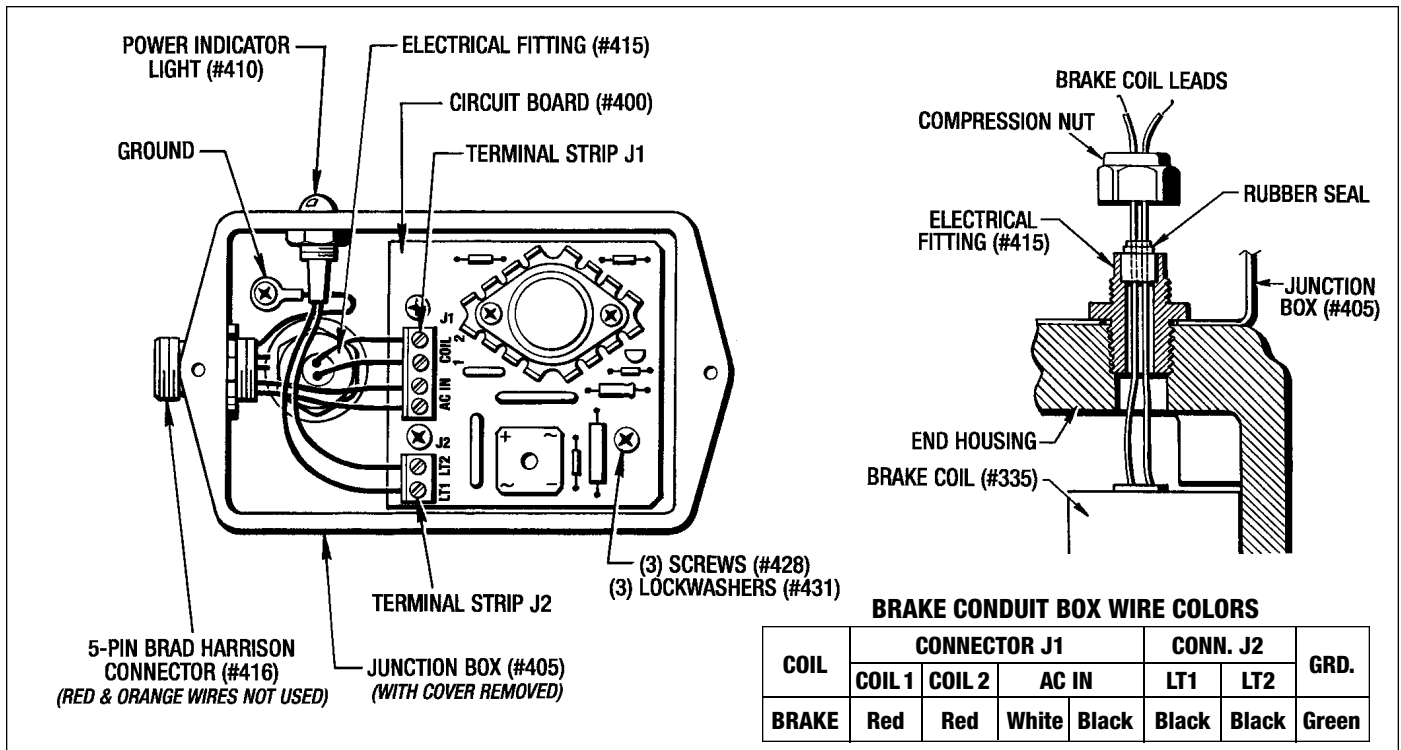

Figure 7.6 - Brake Conduit Box With Cover Removed

7-8 REPLACING WORM SHAFT OIL SEAL (With C-Face Mounted Feed Motor)

(See Figure 8.3 and 8.4)

(MS-100 MagnaShear)

1. Drain the oil from the complete Drive Unit as specified in **Section 4-3 Changing The Oil**.
2. Attach an overhead crane to the Feed Motor and take the motor mounting screws out. Pull the Feed Motor away from the C-Face Adapter (#5).
3. Remove the C-Face Adapter (#5) from the Main Housing (#15).
4. Remove the Gasket (#46) and discard.
5. Press the Oil Seal (#64) out of the C-Face Adapter (#5).
6. Clean out the bore and lightly coat with Permatex #30 Sealant. Press the new Oil Seal (#64) into the C-Face Adapter bore.
7. Place a new Gasket (#46) on and re-attach the C-Face Adapter (#5) to the Main Housing. **Be careful not to damage the Oil Seal Lip when inserting the Worm Shaft (#37) into it.**
8. Re-attach the Feed Motor to the C-Face Adapter (#5).
9. Refill the Drive Unit with fresh oil as directed in Section 4 - Lubrication.

(MS-200 MagnaShear)

1. Drain the oil from the complete Unit as specified in **Section 4-3 Changing The Oil**.
2. Attach an overhead crane to the Feed Motor and take the motor mounting screws out. Pull the Inching Motor away from the C-Face Adapter (#5).
3. Remove the C-Face Adapter (#5) from the Main Housing.
4. Inspect the O-Ring (#77) and replace if necessary.
5. Press the Oil Seal (#64) out of the C-Face Adapter (#5).
6. Clean out the bore and lightly coat with Permatex #30 Sealant. Press the new Oil Seal (#64) into the C-Face Adapter (#5) bore.
7. Inspect the Wear Sleeve (#68) on the Worm Shaft (#37) and, if necessary, replace it with the following procedure described in 7-9.

7-9 REPLACING WEAR SLEEVE (#68)

(MS-200 With C-Face Mounted Feed Motor)

(See Figures 8.3 and 8.4)

1. Remove the Brake End Housing (#309) by taking out the (6) Screws (#316) and (6) Lockwashers (#320).
2. Remove the Gasket (#321) and discard it.
3. Take the Brake Stack Assembly (#337) off the Hub spline (#302) by loosening the (4) Shoulder Bolts in the Stack.

- Remove the Adapter (#308) from the Main Housing Assembly by taking out the (4) Screws (#315) and (4) Lockwashers (#319). Remove and discard Gasket (#322).
- The Worm Shaft (#37) along with Bearing (#57) and Hub (#302) can be manually pushed out of the brake side of the Main Housing Assembly.
- Place the Worm Shaft (#37) into a suitable V-Block Support and with a chisel the same width as the Wear Sleeve (#68) make about 5 or 6 notches in the Wear Sleeve. The Wear Sleeve (#68) can now be removed from the Worm Shaft. (See Figure 7.7)

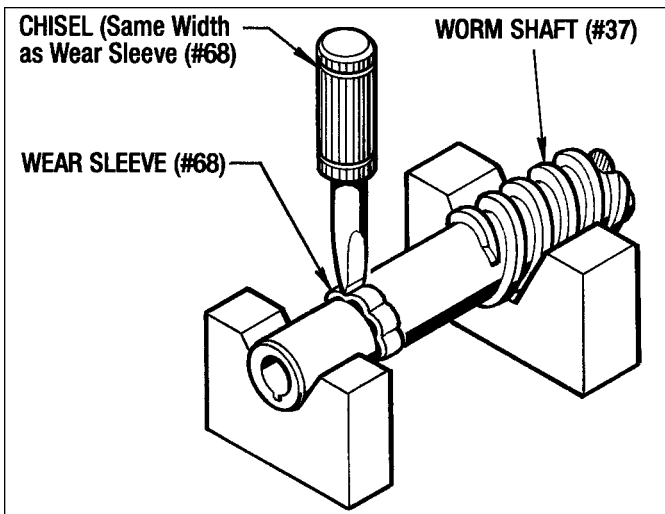

Figure 7.7 - Removing Wear Sleeve (#68)

A Wear Sleeve Installation Tool must be used to install the Wear Sleeve (#68) back on the Worm Shaft (#37).

To order the **Installation Tool** from Force Control, use **Part Number 601-72-003**

If you wish to make your own, dimensions are given in Figure 7.8.

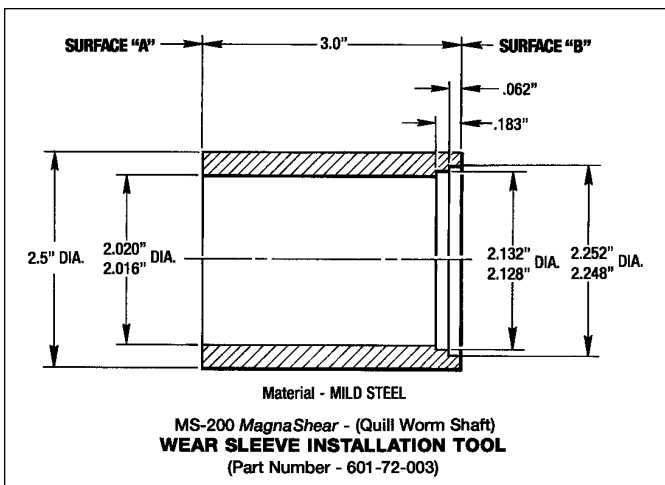

Figure 7.8 - Wear Sleeve Installation Tool # 601-72-003

- Place the Worm Shaft in an arbor press as shown in Figure 7.9. **Step 1** - Press the Wear Sleeve (#68) on to the Worm Shaft with **Surface "A"** of the Installation Tool. **Step 2** - Turn the Installation Tool over and with **Surface "B"** finish pressing the Wear Sleeve (#68) on the Worm Shaft until it bottoms out on the shaft shoulder.

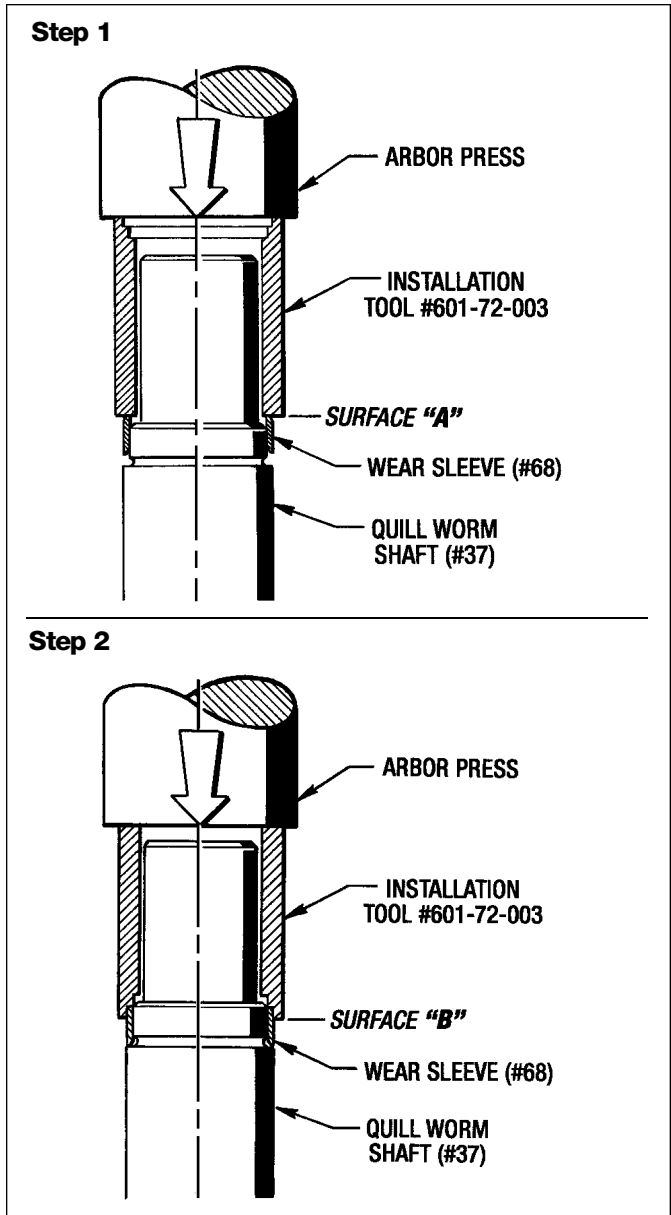

Figure 7.9 - Installing Wear Sleeve (#68) on Quill Worm Shaft

- Reinstall the Worm Shaft back into the Main Housing from the brake side. Make sure the Bearing Spacer (#23) is still in the bearing bore of the main housing.
- Lubricate the O-Ring (#77) and install it on the C-Face Adapter (#5).

10. Re-attach the C-Face Adapter (#5) to the Main Housing with (4) Lockwashers (#174) and (4) Screws (#145). **Be careful not to damage the Oil Seal Lip when inserting the worm shaft into it.**
11. Install a new Gasket (#322) and mount the Adapter (#308) with (4) Lockwashers (#319) and (4) Screws (#315) back on to the Main Housing Assembly.
12. Align spline teeth of Discs in the Brake Stack Assembly (#337) and install it on to the Hub spline. Apply Blue Loctite to the (4) shoulder bolts and tighten with a T-handle allen wrench.
13. Install a new Gasket (#321) and attach the Brake End Housing (#309) with (6) Lockwashers (#320) and (6) Screws (#316). **Apply Blue Loctite and Torque to 25 Ft. Lbs.**
14. Re-attach the Feed Motor to the C-Face Adapter.
15. Refill the Drive Unit with fresh oil as directed in **Section 4 - Lubrication.**

7-10 REPLACING WORM SHAFT OIL SEAL (MS-100 and MS-200 With Belt Drive)

(See Figure 8.3)

1. Drain the oil from the complete unit as specified in **Section 4-3 - Changing The Oil.**
2. Remove the Drive Belt and Sheave from the end of the Worm Shaft (#37). Also remove the Key (#40).
3. Remove the Bearing Retainer (#22) by taking out the (4) Screws (#145) and (4) Lockwashers (#174).
4. Take the Shims (#132) off and save for reassembly.
5. Press the Oil Seal (#63) out of the Bearing Retainer (#22).
6. Clean the oil seal bore out and lightly coat it with Permatex #30 Sealant. Press the new Oil Seal (#63) into the Bearing Retainer (#22) with an arbor press.

(MS-100 MagnaShear)

7. Reinstall the Shim (#132) and the Bearing Retainer (#22) back on the Main Housing Assembly with (4) Lockwashers (#174) and (4) Screws (#145). **Be careful not to damage the oil seal lip when inserting the Worm Shaft.**
8. Re-install the Key (#40), Drive Sheave and Drive Belt back on the worm shaft.
9. Replace all drain plugs and refill the unit with fresh oil as specified in **Section 4 - Lubrication.**

(MS-200 MagnaShear)

The **MS-200 MagnaShear** has a Wear Sleeve (#69) on the Worm Shaft. Check this Wear Sleeve (#69) for any nicks, scratches or other damage that would cause leak-

age. If it doesn't need replacing, reinstall the Bearing Retainer, Shim, Key, Drive Sheave and Drive Belt as described for the MS-100 in steps 7, 8 and 9.

If it does need replaced then follow the procedure given in the next Section 7-11 - Replacing Wear Sleeve (#69).

7-11 REPLACING WEAR SLEEVE (#69) (MS-200 MagnaShear With Belt Drive Only)

(See Figures 8.3 and 8.4)

1. Remove the Brake End Housing (#309) by taking out the (6) Screws (#316) and (6) Lockwashers (#320).
2. Remove the Gasket (#321) and discard it.
3. Take the Brake Stack (#337) off the Hub spline (#302) by loosening the (4) Shoulder Bolts in the Stack.
4. Remove the Adapter (#308) from the Main Housing Assembly by taking out the (4) Screws (#315) and (4) Lockwashers (#319). Remove and discard Gasket (#322).
5. From the drive side, tap the end of the Worm Shaft (#37) with a wooden mallet until the Bearing Spacer (#23) and the Bearing Cup (#56) located on the brake side is knocked out of the bearing bore. Continue pulling the Worm Shaft out of the Main Housing.

NOTE:

The (2) Bearing Cones (#55) will remain on the Worm Shaft and the other Bearing Cup (#56), located on the drive side will remain in the bearing bore. It is also not necessary to remove the Hub (#302) and the Collet (#306) from the Worm Shaft to replace the Wear Sleeve.

6. Place the Worm Shaft (#37) into a suitable V-block support or vice and with a chisel the same width as the Wear Sleeve (#69) make about 5 or 6 notches in the Wear Sleeve. The Wear Sleeve (#69) can now be removed from the Worm Shaft. (See Figure 7.7)

A Wear Sleeve Installation Tool must be used to install the Wear Sleeve (#69) back on the Worm Shaft (#37).

To order the **Installation Tool** from Force Control, use **Part Number 601-72-002.**

If you wish to make your own, dimensions are given in Figure 7.10 on the next page.

7. Place the Worm Shaft in an arbor press as shown in Figure 7.11. **Step 1** - Press the Wear Sleeve (#69) on to the Worm Shaft with **Surface "A"** of the Installation Tool. **Step 2** - Turn the Installation Tool over and with **Surface "B"** finish pressing the Wear Sleeve on the Worm Shaft until it bottoms out on the shaft shoulder.

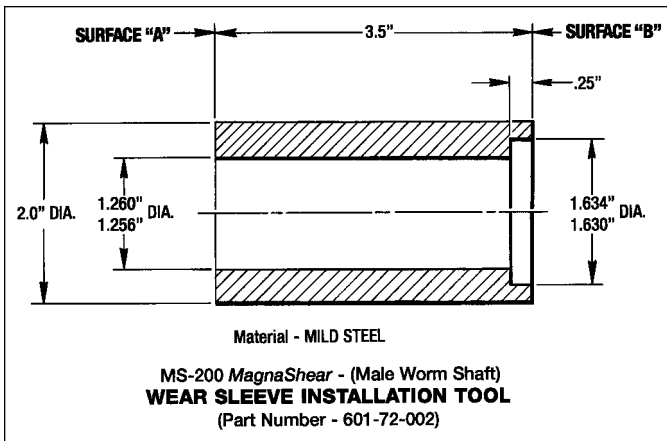

Figure 7.10 - Wear Sleeve Installation Tool #601-72-002

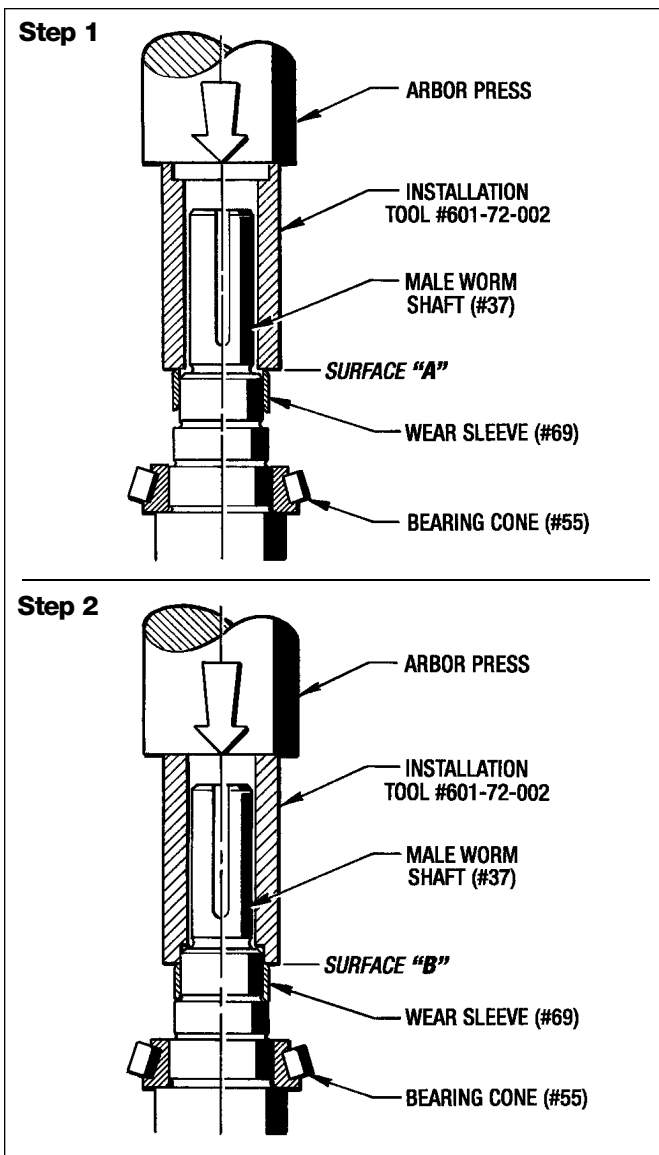

Figure 7.11 - Installing Wear Sleeve on Male Worm Shaft

8. Slide the Worm Shaft (#37) back into the Main Housing bore.

9. Place a Bearing Cup (#56) and the Spacer (#23) into the bearing bore located on the brake side. On the drive side, replace the remaining Bearing Cup (#56).
10. Install the Shims (#132) and the Bearing Retainer (#22) with the (4) Lockwashers (#174) and (4) Screws (#145) back on the drive side.
11. Install a new Gasket (#322) and attach the Adapter (#308) with (4) Lockwashers (#319) and (4) Screws (#315) to the brake side of the Main Housing.
12. The **End Play** of the Worm Shaft must be checked before going any further. This can be done by setting a Dial Indicator on the end of the Worm Shaft and manually pushing the shaft in and out while rotating it. The **End Play should be between .002" and .004"**. Add or subtract Shims (#132) as necessary. (See Figure 7.12)

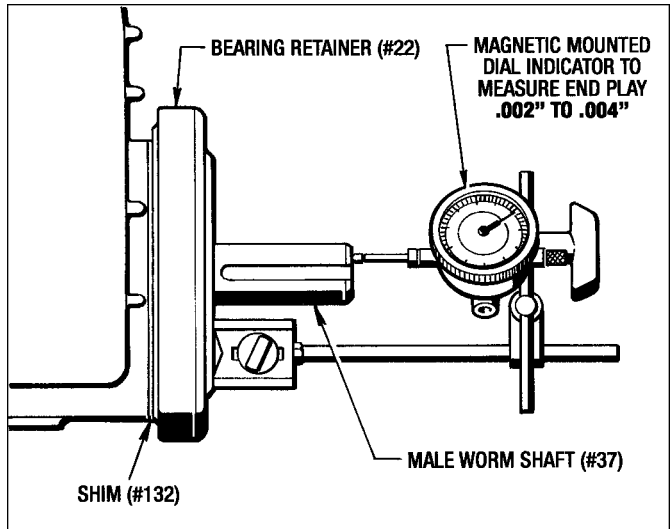

Figure 7.12 - Checking Worm Shaft End Play

13. Replace Gasket (#322) and mount the Adapter (#308) with (4) Lockwashers (#319) and (4) Screws (#315) back on to the Main Housing.
14. Align the spline teeth of Discs in the Brake Stack Assembly (#337) and install it on to the Hub spline. **Apply Blue Loctite to the (4) shoulder bolts and tighten with a T-handle allen wrench.**
15. Install new Gasket (#321) and attach the Brake End Housing (#309) with (6) Lockwashers (#320) and (6) Screws (#316). **Apply Blue Loctite and Torque to 25 Ft. Lbs.**
16. Replace the Key (#40), Drive Sheave, Drive Belt and any other parts removed for repair.
17. Refill the unit with fresh oil to the center of the sight gauge as described in **Section 4 - Lubrication.**

Section 8

ILLUSTRATED PARTS LIST

8-1 GENERAL INFORMATION

This section illustrates, lists and describes all parts for the **MagnaShear Two Speed Drive**. Parts are identified on the exploded views with Part Reference Numbers. These Numbers correspond to the Part Reference Number given in the Parts Lists. The Part Name and Quantity Used is also given in the Parts List. This Part Reference Number, Part Name and Quantity should be used when ordering Replacement Parts.

8-2 DRIVE MOTORS

The Drive Motors used with these **MagnaShear Two Speed Drives** are standard motors and may be repaired or replaced by any qualified Motor Re-build Facility or Supplier.

8-3 FACTORY REBUILD SERVICE

Reconditioning Service is offered by Force Control Industries, Inc. at the factory. A complete factory rebuild will be 50% the cost of a new unit if the housings are reusable. If Housings need to be replaced, there will be an additional cost.

Contact Force Control Industries, Inc. for authorization and shipping instruction before returning a drive unit for this service. Force Control cannot be responsible for units returned to the factory without prior notice and authorization.

Care must be given to the packing of returned drives. Always protect mounting feet by attaching to a skid.

Shipment-damaged drives always delays repairs. It is usually impossible to recover damage costs from the carrier. When possible, describe the problem experienced on your shipping papers.

Return to: **Force Control Industries, Inc.**
3660 Dixie Highway
Fairfield, Ohio 45014

Phone: (513) 868-0900

Fax: (513) 868-2105

E-Mail: info@forcecontrol.com

8-4 ORDERING REPLACEMENT PARTS

When ordering replacement parts, please specify all of the following information:

1. Drive Model Number (On the Name Plate.)
2. Drive Serial Number (On the Name Plate.)
3. Part Reference Number (From the parts list or exploded view drawing.)
4. Part Name (From the parts list.)
5. Quantity (From the parts list.)
6. Complete Shipping Information.

Failure to include information for items 1 through 6 will only delay your parts order. Unless another method is specified for item 6, parts weighing less than 150 Lbs. will be shipped United Parcel Service. Parts weighing more than 150 Lbs. will be shipped Motor Freight. Air freight and other transportation services are available but only if specified on your order.



8-5 NAME PLATE AND MODEL NUMBER

The Name Plate shown is located on the Brake End Housing.

EXAMPLE: 0-1-MS-2-H-3-F-2-A-3-R-1

MS-200 MagnaShear Two Speed Drive, 48:1 Ratio, 150 Ft. Lbs. Torque; Main Motor - 1-7/8" Dia. Shaft, 12-1/2" AK Pilot; Feed Motor - Horizontal Mounted C-Face with 8-1/2" AK Register and 1-3/8" U Dia. Shaft, with Manual Release.

MagnaShear TWO SPEED DRIVE MODEL NUMBER

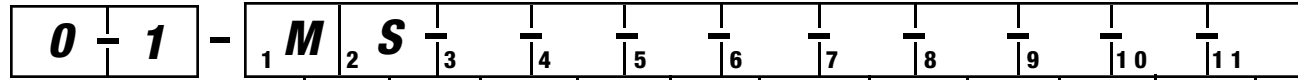

(1, 2, 3) SIZE

- 1** = MS-100
- 2** = MS-200

(4) GEAR RATIO

- | | |
|-----------------|-----------------|
| A = 6:1 | F = 24:1 |
| B = 10:1 | G = 30:1 |
| C = 12:1 | H = 48:1 |
| D = 15:1 | J = 60:1 |
| E = 20:1 | K = 80:1 |

(5) CLUTCH TORQUE RATING

MS-100

- 1** = 21 Ft. Lbs.
- 2** = 42 Ft. Lbs.
- 3** = 63 Ft. Lbs.
- 4** = 84 Ft. Lbs.

MS-200

- 1** = 50 Ft. Lbs.
- 2** = 100 Ft. Lbs.
- 3** = 150 Ft. Lbs.
- 4** = 200 Ft. Lbs.

(6) MAIN MOTOR SHAFT DIA.

MS-100

- A** = 5/8" FU (56 Fr.)
- B** = 7/8" FU (182U/184U Fr.; 213U/215U Fr.)
- C** = 1-1/8" FU (254U/256U Fr.)
- S** = SEW Euro Drive

MS-200

- D** = 1-3/8" FU (284U/286U Fr.)
- E** = 1-5/8" FU (324U/326U Fr.)
- F** = 1-7/8" FU (324U/326U Fr.)
- S** = SEW Euro Drive

(7) MAIN MOTOR PILOT

MS-100

- 4** = 4-1/2" AK (56, 182U/184U Fr.)
- 8** = 8-1/2" AK (213U/215U Fr.; 254U/256U Fr.)
- K** = 90/100
- L** = 112M/132S
- M** = 132M/160M
- N** = 160L/180L

SEW Euro Drive
IEC Frames

MS-200

- 0** = 10-1/2" AK (284U/286U Fr.)
- 2** = 12-1/2" AK (324U/326U Fr.)
- M** = 132M/160M
- N** = 160L/180L

SEW Euro Drive
IEC Frames

(11) REVISION
(By Force Control)

(10) RELEASE

- R** = Release
- N** = No Release

(9) FEED MOTOR MOUNTING

- 1** = C-Face, 4-1/2 AK, 7/8 U
- 2** = C-Face, 8-1/2 AK, 1-1/8 U
- 3** = C-Face, 8-1/2 AK, 1-3/8 U
- 4** = Foot Mounted, 182U/184U Fr.
- 5** = Foot Mounted, 213U/215U Fr.
- 6** = Foot Mounted, 143T/145T Fr.
- 7** = Foot Mounted, 182T/184T Fr.
- 8** = Foot Mounted, 213T/215T Fr.

- A** = C-Face, 4-1/2 AK, 7/8 U
- B** = C-Face, 8-1/2 AK, 1-1/8 U
- C** = C-Face, 8-1/2 AK, 1-3/8 U

Long Coupled

- J** = 80
- K** = 90
- L** = 100*

SEW Euro Drive
IEC Frames

- M** = 80 C-Face
- N** = 90 C-Face
- P** = 100 C-Face

SEW Euro Drive
IEC Frames
Long Coupled

* NOTE: 100 IEC available on MS-200 only. Must use Optional "A" Flange SEW Euro Drive.

(8) ASSEMBLY CONFIGURATIONS

(See Next Page)

(8) ASSEMBLY CONFIGURATIONS (All Views Looking at Motor Shaft.)

MagnaShear C-Face Mounted Feed Motor

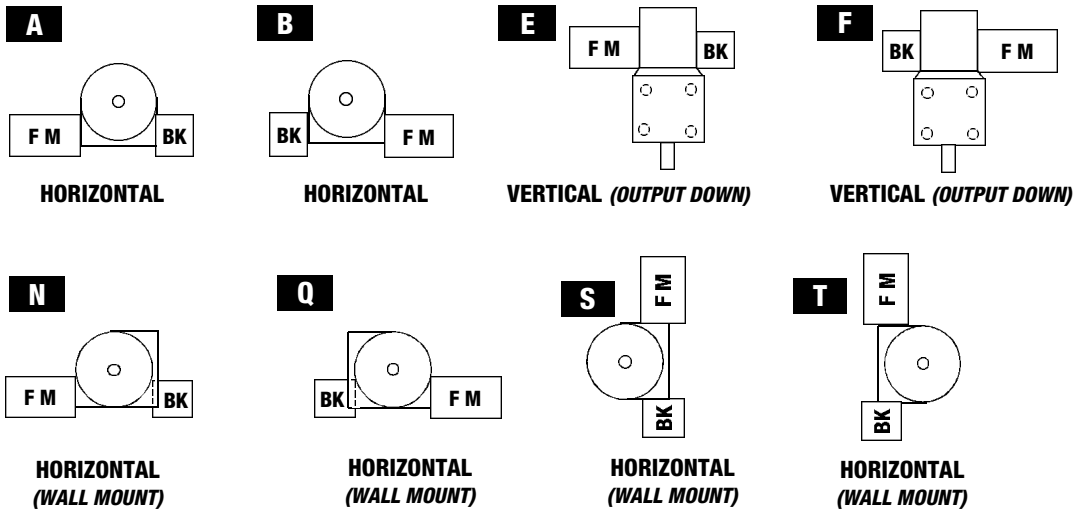

MagnaShear Foot Mounted Feed Motor

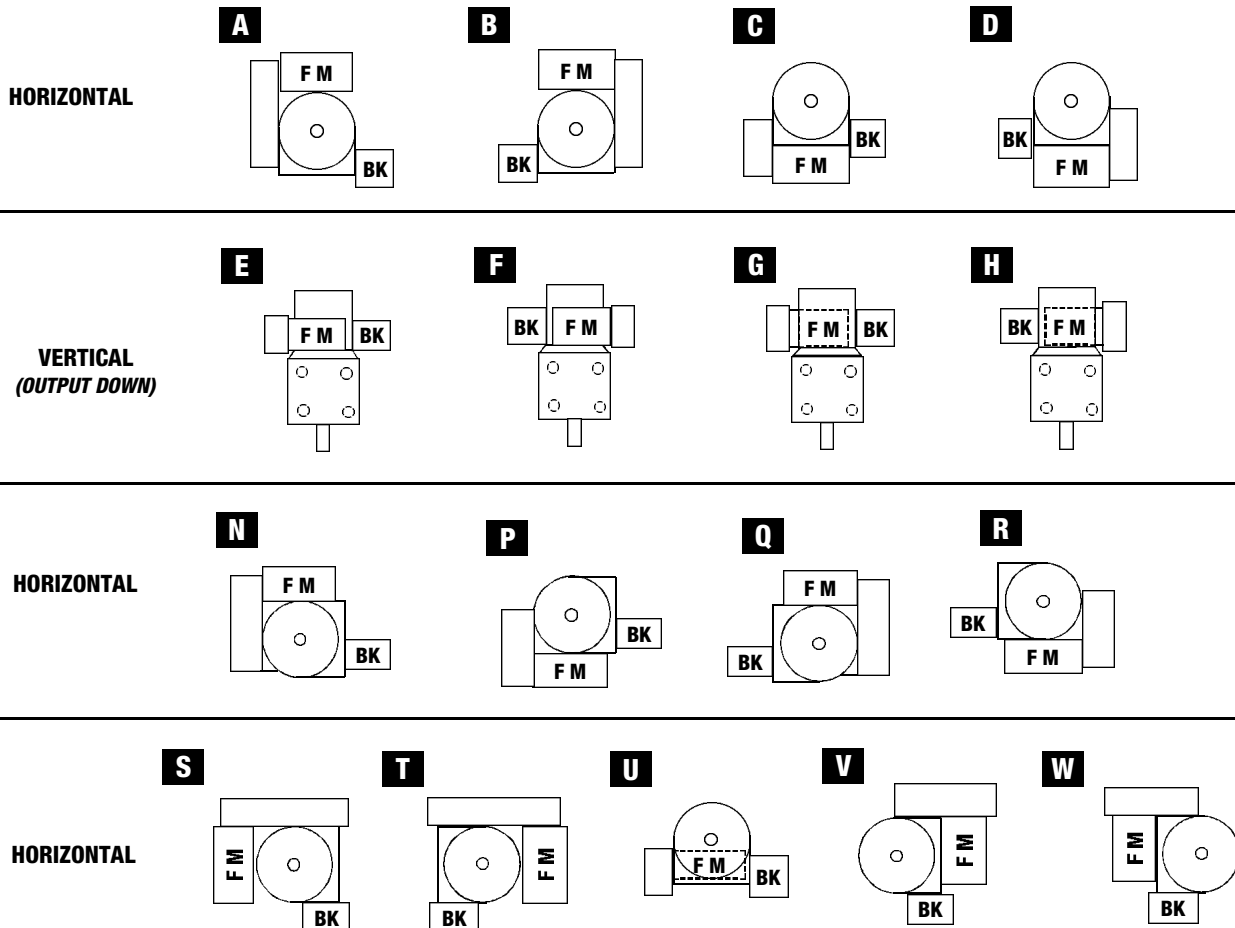

REPAIR PARTS LIST
MS-100 MagnaShear TWO SPEED DRIVE
 (Figure 8.1)

Ref. No.	Part Name	Qty.	Ref. No.	Part Name	Qty.
1	C-Face Adapter.....	1	92	Roll Pin, 1/4 x 1-1/4	4
2	Hub.....	1	131	Bearing Shim, .005"	AR
6	Collet.....	1	136	Shim (.002" Red)	AR
14	Dowel Pin, 1/4 x 3/4	2	137	Shim (.005" Blue)	AR
15	Main Housing	1	138	Shim (.010" Brown).....	AR
19	Thrust Plate	1	141	Hex Hd. Cap Screw, 3/8-16 x 1-1/4"	4
20	Input Shaft	1	142	Hex Hd. Cap Screw	4
21	Spacer	1	143	Hex Hd. Cap Screw, 1/2-13 x 5".....	1
31	End Housing.....	1	144	Soc. Hd. Cap Screw, 3/8-16 x 5-1/2"	7
32	Armature.....	1	163	Flat Washer, #10.....	3
33	Shim, Brass	1	169	Lock Washer.....	4
35	Holding Coil.	1	170	Lock Washer, 3/8".....	4
**36	Clutch Disc Stack	1	174	Lock Washer, Hi-Collar, 3/8".....	7
38	Worm Gear.....	1	177	Dyna-Seal, 3/8".....	4
39	Key	1	180	Soc. Hd. Cap Screw, 3/8-24 x 7/8".....	4
43	Copper Washer Gasket	1	190	Reducer Bushing, 3/8 x 1/4	1
44	Shim	AR	191	Pipe Plug, Mag. Sq. Hd., 1/4 NPT	2
**45	Gasket	1	192	Pipe Plug, Mag. Sq. Hd., 1/2 NPT	1
*50	Ball Bearing	1	193	Pipe Plug, 3/4 NPT.....	1
*51	Ball Bearing	1	194	Pipe Plug, 1/8 NPT.....	1
*52	Ball Bearing	1	195	Pipe Plug, 1/2 NPT.....	1
*53	Bearing Cone	1	199	45° Street Elbow, 3/8 NPT	1
*54	Bearing Cup	1	242	Button Hd. Cap Screw, 10-24 x 3/8".....	3
*62	Oil Seal.....	1	243	Button Hd. Cap Screw, 10-24 x 1/4".....	2
*67	Wear Sleeve.....	1	247	Shoulder Bolt, 1/4"	4
*83	Spring	AR	248	Guide Bushing	4
*87	Sight Gauge	1	250	Spirolox Retaining Ring	1
*88	Breather	1	425	Gasket	1
91	Dowel Pin, 3/8 x 1-3/4	8			

NOTES:

- * - Indicates parts in Overhaul Kit.
- ** - Indicates parts in Stack Replacement Kit.
- AR - As Required.

MS-100 MagnaShear TWO SPEED DRIVE

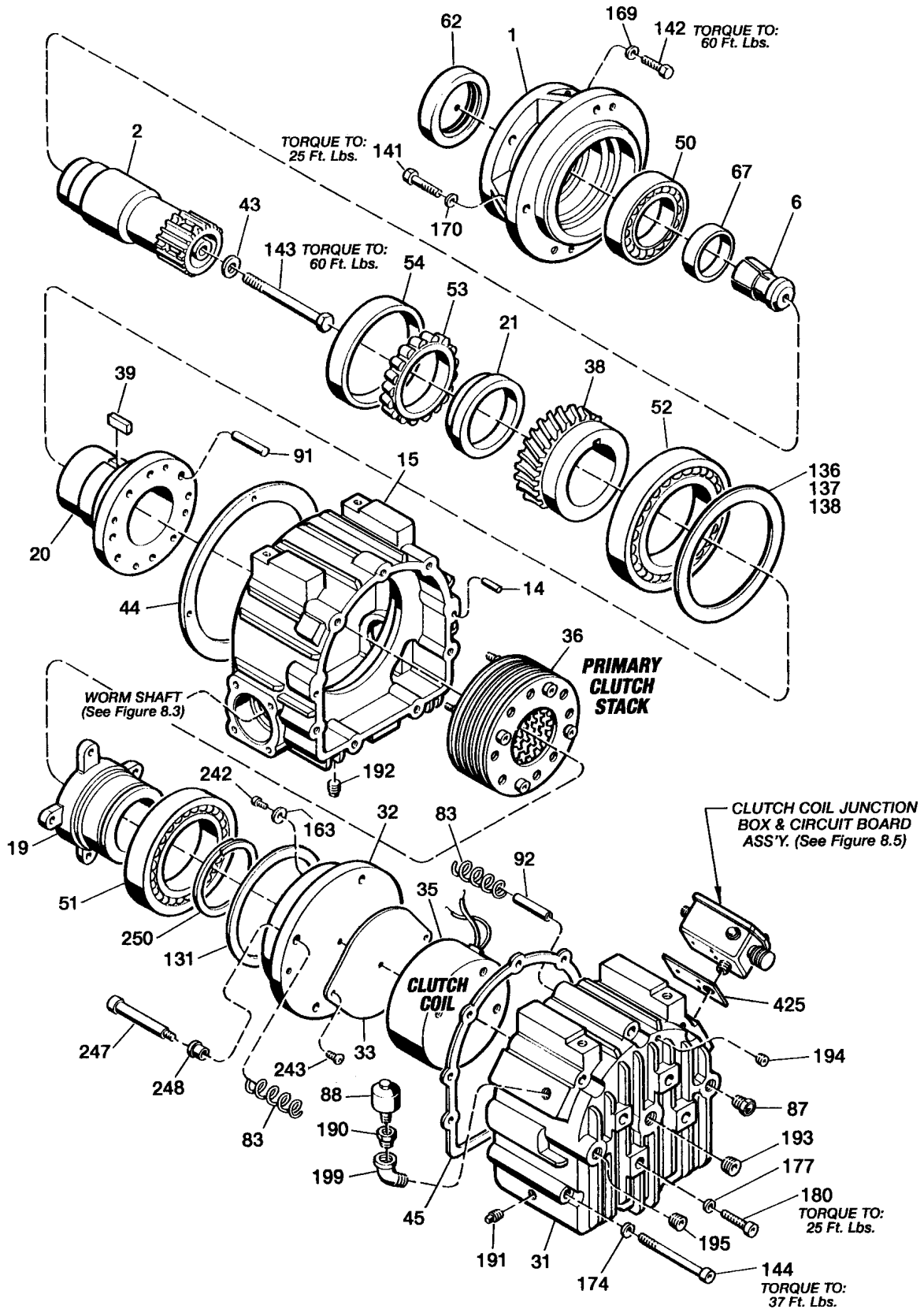

Figure 8.1 - Repair Parts - MS-100 MagnaShear Two Speed Drive

FORCE CONTROL INDUSTRIES, INC.



REPAIR PARTS LIST
MS-200 MagnaShear TWO SPEED DRIVE
 (Figure 8.2)

Ref. No.	Part Name	Qty.	Ref. No.	Part Name	Qty.
1	C-Face Adapter.....	1	92	Roll Pin, 3/8 x 2".....	4
2	Hub	1	131	Bearing Shim	AR
6	Collet.....	1	137	Shim	AR
14	Dowel Pin, 3/8 x 3/4	2	141	Soc. Hd. Cap Screw, 3/8-16 x 1-1/2"	4
15	Main Housing	1	142	Hex Hd. Cap Screw, 1/2-13 x 1-3/4"	4
19	Thrust Plate	1	143	Hex Hd. Cap Screw, 5/8-11 x 5-1/2".....	1
20	Input Shaft	1	144	Soc. Hd. Cap Screw. 3/8-16 x 5-1/2"	7
21	Bearing Retainer.....	1	149	Soc. Hd. Cap Screw, 10-24 x 3/4.....	4
26	Lock Nut	1	150	Soc. Hd. Cap Screw, 1/4-20 x 1-3/4"	4
31	End Housing.....	1	163	Flat Washer	3
32	Armature.....	1	169	Lock Washer, 1/2".....	4
33	Shim, Brass	1	170	Lock Washer, Hi-Collar, 3/8".....	4
35	Holding Coil.	1	174	Lock Washer, Hi-Collar, 3/8".....	7
**36	Clutch Disc Stack	1	176	Lock Washer, #10 Hi-Collar	4
38	Worm Gear.....	1	177	Dyna-Seal, 1/2".....	4
43	Copper Washer Gasket	1	178	Lock Washer, 1/4" Hi-Collar	4
**45	Gasket	1	180	Soc. Hd. Cap Screw, 1/2-20 x 1-3/4"	4
*47	O-Ring	1	190	Reducer Bushing, 3/8 NPT x 1/4 NPT	1
*50	Ball Bearing	1	191	Pipe Plug, Mag. Sq. Hd., 3/8 NPT	2
*51	Ball Bearing	1	192	Pipe Plug, Mag. Sq. Hd., 1/2 NPT	1
*53	Bearing Cone	1	194	Pipe Plug, 1/4 NPT.....	1
*54	Bearing Cup	1	195	Pipe Plug, 3/4 NPT.....	1
*58	Bearing Cone	1	196	Pipe Plug, 1" NPT.....	1
*59	Bearing Cup	1	199	45° Street Elbow, 3/8 NPT	1
*62	Oil Seal.....	1	242	Button Hd. Cap Screw, 10-24 x 3/8".....	3
*67	Wear Sleeve.....	1	243	Button Hd. Cap Screw, 10-24 x 1/4".....	2
82	Wave Spring	1	247	Shoulder Bolt, 3/8"	4
*83	Spring	AR	248	Guide Bushing	4
*87	Sight Gauge	1	250	Retaining Ring	1
*88	Breather	1	425	Gasket	1
91	Drive Pin, 1/2 x 3".....	4			

NOTES:

* - Indicates parts in Overhaul Kit.

** - Indicates parts in Stack Replacement Kit.

AR - As Required.

REPAIR PARTS LIST
MS-100 and MS-200 MagnaShear TWO SPEED DRIVE
 (Figure 8.3)

Ref. No.	Part Name	Qty.	Ref. No.	Part Name	Qty.
5	C-Face Adapter.....	1	*69	Wear Sleeve	1
22	Bearing Retainer.....	1	*77	O-Ring	1
23	Bearing Spacer.....	1	132	Shim	AR
29	Spacer	1	145	Soc. Hd. Cap Screw	
37	Worm Shaft.....	1		(MS-100) 3/8-16 x 1-3/4".....	4
40	Key	1		(MS-200) 3/8-16 x 1-1/4".....	4
*46	Gasket	1	148	Cap Screw	
*55	Bearing Cone	2		(4-1/2" Register) 3/8-16 x 1"	4
*56	Bearing Cup	2		(8-1/2" Register) 1/2-13 x 1-1/2"	4
*57	Ball Bearing	1	154	Hex Hd. Cap Screw, 3/8-16 x 1".....	4
*63	Oil Seal.....	1	170	Lock Washer, 3/8".....	4
*64	Oil Seal.....	1	172	Lock Washer, 3/8".....	4
*68	Wear Sleeve.....	1	174	Lock Washer, 3/8 Hi-Collar.....	4

NOTES:

* - Indicates parts in Overhaul Kit.
 AR - As Required.

MagnaShear TWO SPEED DRIVE
(INCHING SPEED WORM SHAFT WITH C-FACE ADAPTER)

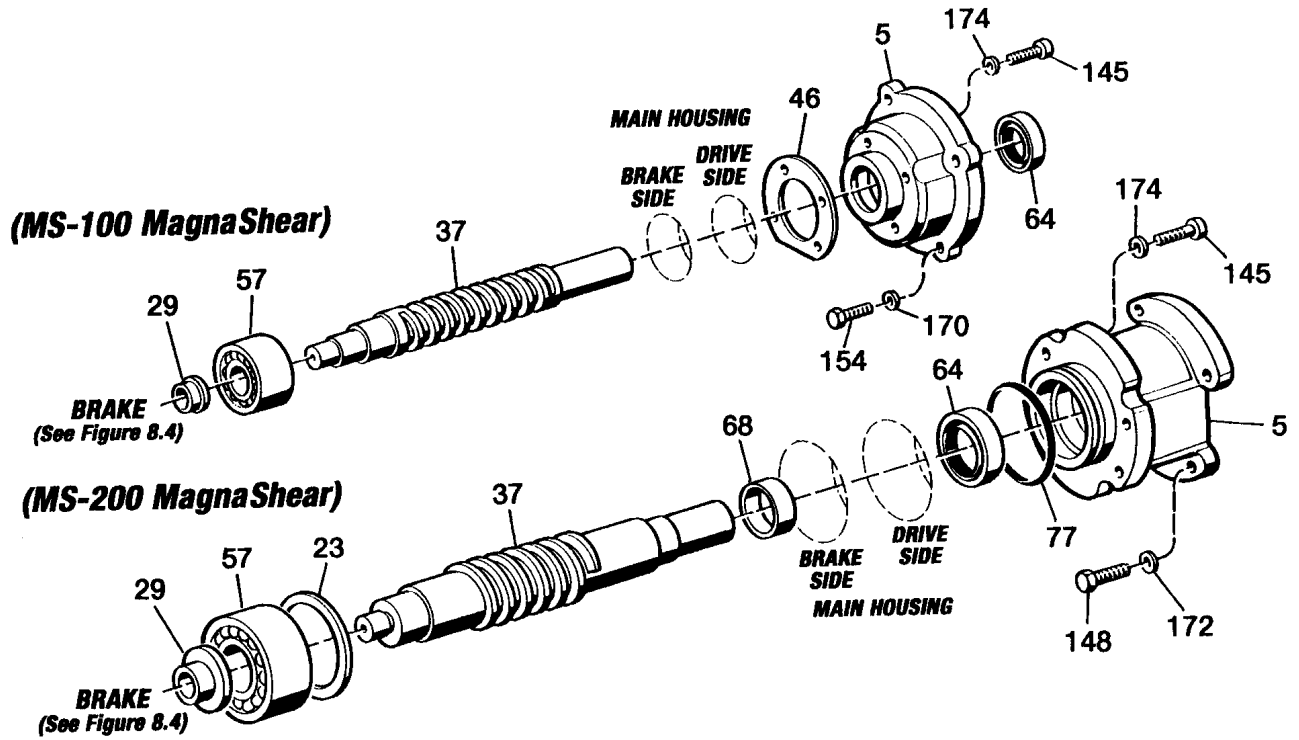

(INCHING SPEED WORM SHAFT WITH BELT DRIVE)

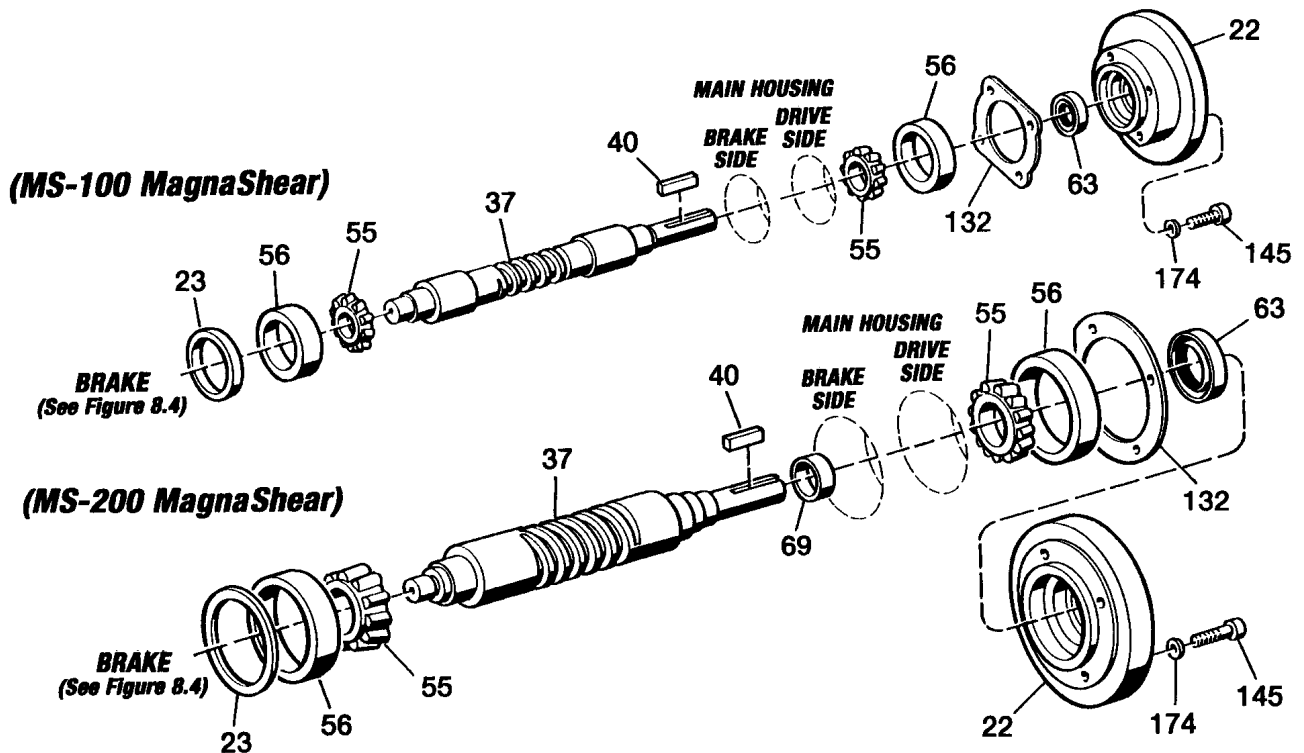

Figure 8.3 - Repair Parts - Inching Speed Worm Shaft

FORCE CONTROL INDUSTRIES, INC.

REPAIR PARTS LIST
MS-100 and MS-200 MagnaShear TWO SPEED DRIVE
 (Figure 8.4)

Ref. No.	Part Name	Qty.	Ref. No.	Part Name	Qty.
135	Shim.....	1	334	Copper Gasket Washer, 3/8".....	1
224	Button Hd. Cap Screw, #10-24 x 1/4"	2	335	Brake Coil	1
270	Soc. Hd. Cap Screw (MS-100) 1/4-20 x 1/2".....	4	*336	Spring	6
	(MS-200) 1/4-20 x 5/8".....	4	**337	Brake Stack Assembly.....	1
271	Lock Washer, 1/4" Hi-Collar.....	4	347	Shoulder Bolt.....	2
302	Hub	1	348	Guide Bushing, 1/4" ID	2
306	Collet, 7/8"	1	351	Hex Hd. Cap Screw (MS-100) 3/8-16 x 1-1/4"	1
308	Adapter	1		(MS-200) 3/8-16 x 1-1/2"	1
309	Brake End Housing	1	357	Dowel Pin (MS-100) 1/4" x 1-1/4"	4
315	Soc. Hd. Cap Screw, 3/8-16 x 2-3/4".....	4		(MS-200) 3/8" x 1-1/2"	4
316	Soc. Hd. Cap Screw (MS-100) 5/16"-18 x 3-1/2".....	6	373	Pipe PLug, 1/2" NPT	4
	(MS-200) 3/8"-16 x 4".....	6	374	Pipe PLug, Magnetic 3/8" NPT	1
319	Lock Washer, 3/8" Hi-Collar.....	4	375	Pipe Plug, 1/4"NPT (MS100 Only).....	1
320	Lock Washer (MS-100) 5/16"	6	377	Soc. Hd. Cap Screw (MS-100)1/4"-28 x 3/4".....	4
	(MS-200) 3/8"	6		(MS-200) 5/16"-24 x 1"	4
**321	Gasket	1	378	Dyna-Seal Washer	
*322	Gasket	1		(MS-100) 1/4".....	4
332	Armature Plate.....	1		(MS-200) 5/16"	4
333	Armature Ring	1	425	Gasket	1

NOTES:

* - Indicates parts in Overhaul Kit.

** - Indicates parts in Stack Replacement Kit.

MS-100 and MS-200 MagnaShear TWO SPEED DRIVE
(SECONDARY BRAKE STACK and BRAKE ASSEMBLY)

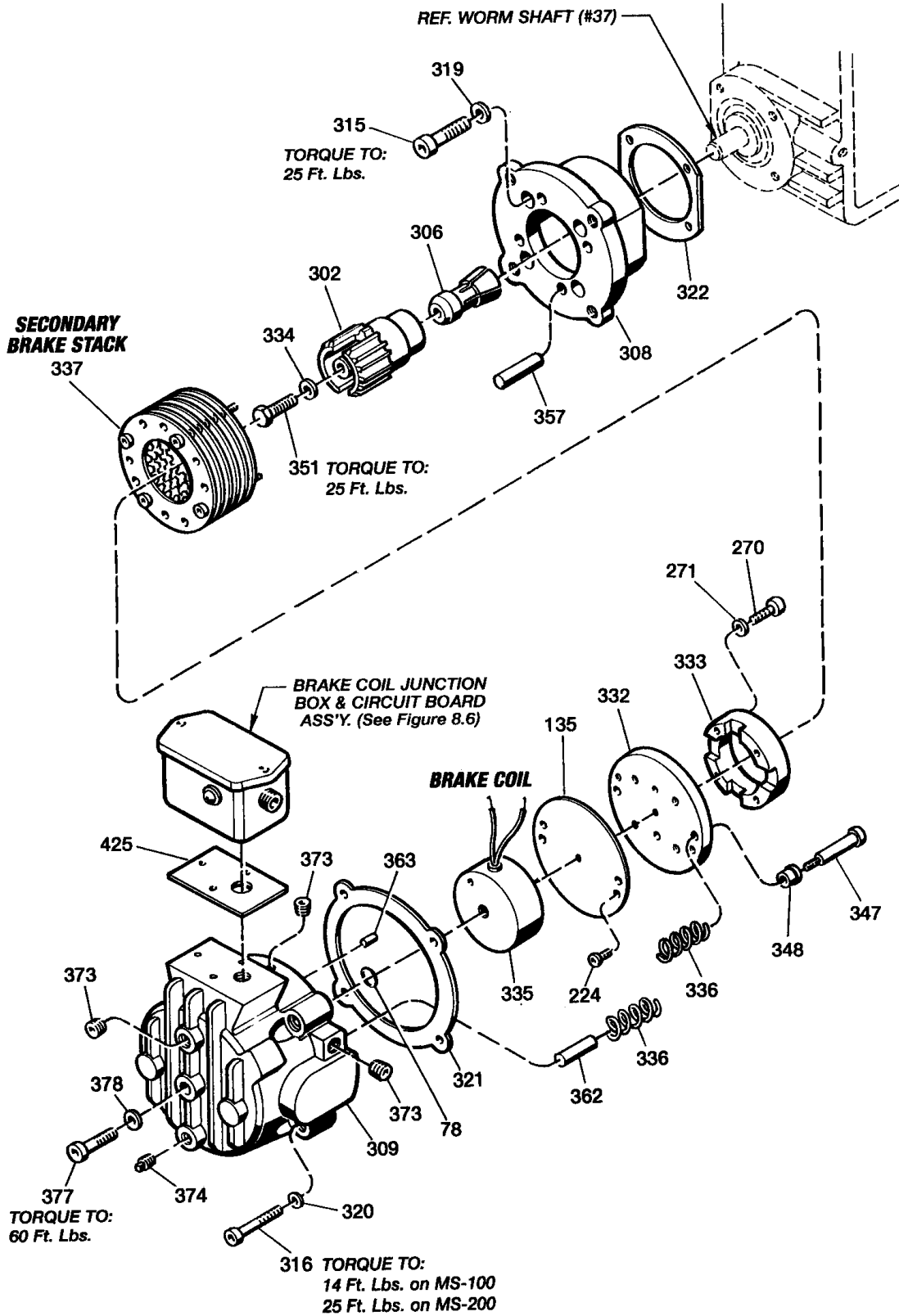

Figure 8.4 - Repair Parts - Secondary Brake Stack and Brake Assembly

FORCE CONTROL INDUSTRIES, INC.



REPAIR PARTS LIST

MS-100 and MS-200 *MagnaShear* TWO SPEED DRIVE

(Figure 8.5)

Ref. No.	Part Name	Qty.	Ref. No.	Part Name	Qty.
400	Circuit Board	1	428	Pan Hd. Screw, 8-32 x 1/2"	3
405	Junction Box	1	429	Button Hd. Cap Screw, 1/4"-20 x 1/2"	3
410	Indicator Lamp.....	1	431	Lock Washer, Internal #8.....	3
415	Electrical Fitting	1	432	Lock Washer, 1/4"	3
416	Receptacle 5-Pin	1	433	Lock Washer, #10	1
417	Receptacle Nut	1	434	Flat Washer, #10	1
420	External Heat Sink.....	1	435	Stand-Off	3
426	Button Hd. Screw, #10-32 x 1/4"	1	*437	O-Ring	1
427	Soc. Hd. Screw, #10-32 x 3/4".....	1			

NOTES:

* - Indicates parts in Overhaul Kit.

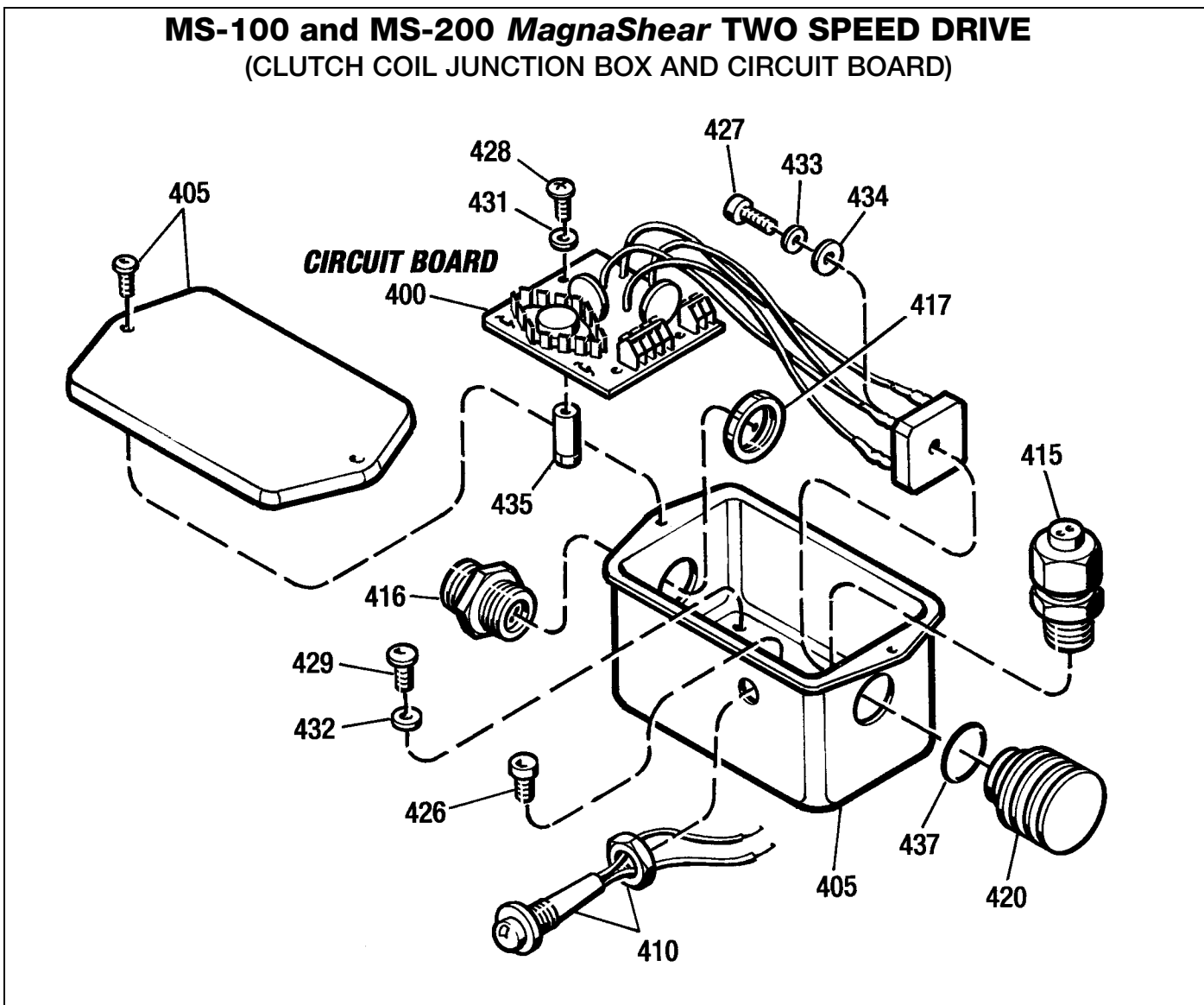

Figure 8.5 - Repair Parts - Clutch Coil Junction Box and Circuit Board

REPAIR PARTS LIST
MS-100 and MS-200 *MagnaShear* TWO SPEED DRIVE
 (Figure 8.6)

Ref. No.	Part Name	Qty.	Ref. No.	Part Name	Qty.
398	Knock-Out Plug	1	426	Button Hd. Screw, #10-32 x 1/4"	1
400	Circuit Board	1	428	Pan Hd. Screw, 8-32 x 1/2"	3
405	Junction Box	1	429	Button Hd. Cap Screw, 1/4"-20 x 1/2"	3
410	Indicator Lamp.....	1	431	Lock Washer, Internal #8.....	3
415	Electrical Fitting	1	432	Lock Washer, 1/4"	3
416	Receptacle 5-Pin	1	435	Stand-Off	3
417	Receptacle Nut	1			

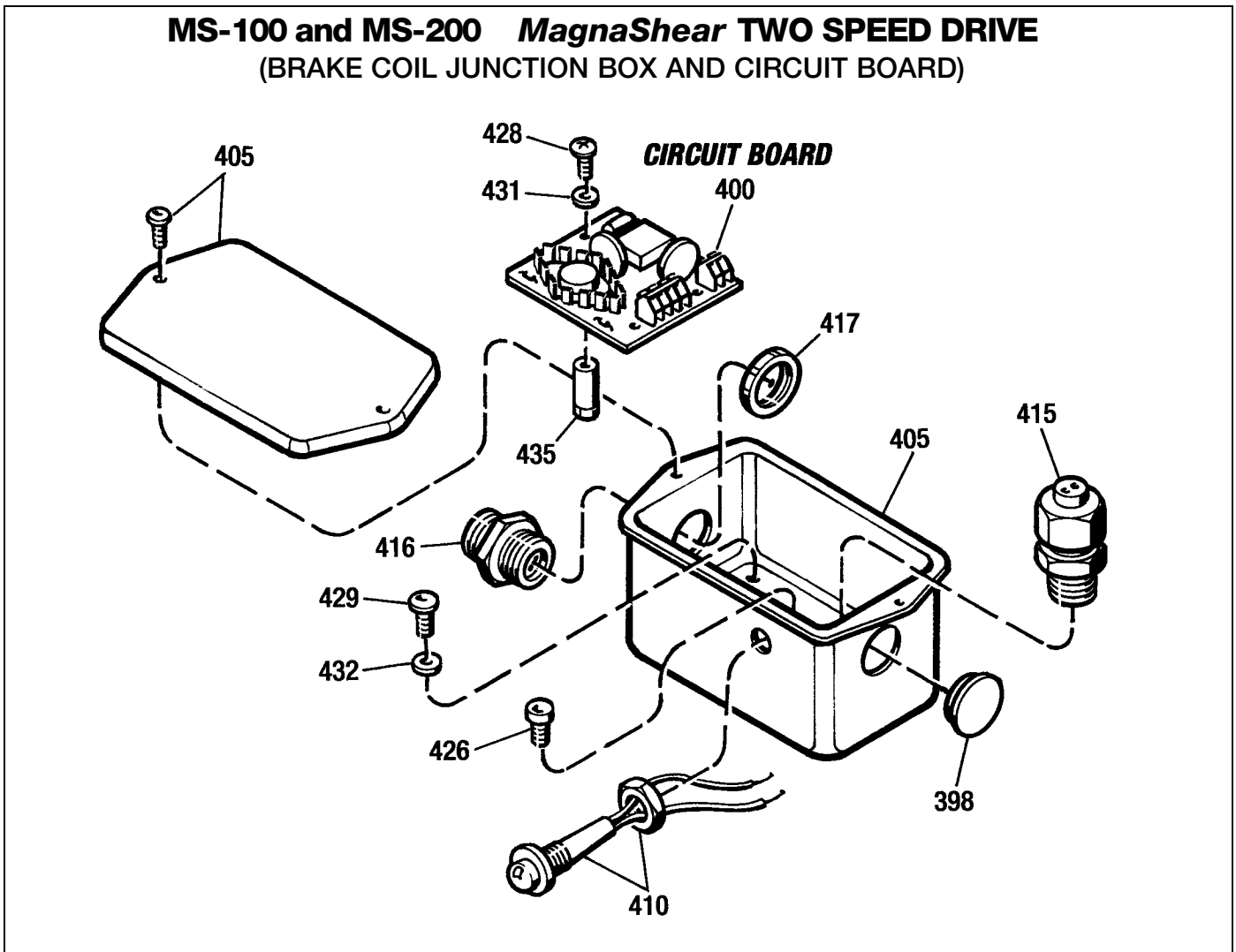

Figure 8.6 - Repair Parts - Brake Coil Junction Box and Circuit Board

FORCE CONTROL INDUSTRIES, INC.
Worldwide Leader in Oil Shear Technology

*Providing Today's Industries
with Oil Shear Clutch & Brake Drives
and Electronic Drive Systems That Delivers:
Flexibility • Efficiency
Endurance • Performance
Dependability*

“Built to Last - Guaranteed to Perform”



FORCE CONTROL INDUSTRIES, INC.

MAIN OFFICE

P.O. Box 18366
Fairfield, Ohio 45018

3660 Dixie Highway
Fairfield, Ohio 45014

Tel: (513) 868-0900
Fax: (513) 868-2105

E-Mail: info@forcecontrol.com
Web: www.forcecontrol.com