

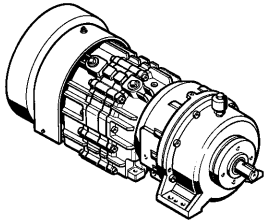

PLANET HUB & GEAR ROLL PIN UPGRADE KIT (FOR PLANETARY GEAR REDUCER)



Size 20P Posidyne Indexing Drive



Size 20P Posidyne Indexing Drive

Problem - There are (4) Roll Pins (#879) that holds the (4) Planet Gear Pins (#820) in the Planet Hub (#886). These Roll Pins, under rare circumstances, may break loose and interfere with the Planetary Gear Set. For continuous product improvement, **Force Control Industries, Inc.** has developed a new **Pin Retainment System** that extends the life of the Planetary Gear Reducer.

Solution - Remove the (4) Roll Pins (#879) and replace them with (4) Dog Pt. Set Screws (#877), using Loctite Thread Adhesive on the screw threads. The Planet Hub (#886) will need to be drilled and tapped for the (4) Dog Pt. Set Screws (#877).

This Upgrade Kit enables you to remove these (4) Roll Pins (#879), drill and tap the Planet Hub (#886) and install the (4) new Dog Pt. Set Screws (#877). There is an English Upgrade Kit and a Metric Upgrade Kit.

The English Upgrade Kit #02-20-901 contains:

- ◆ (4) Dog Pt. Set Screws, 1/2"-13 x 1-1/2" Lg.
- ◆ (1) O-Ring (#873)
- ◆ (1) Drill Bit, 27/64" (.422") Dia.
- ◆ (1) Tap, 1/2"-13
- ◆ (1) Blue Loctite #242, .02 Fluid Oz.
- ◆ (1) Instruction Sheet #512-20P-001-00

The Metric Upgrade Kit #02-20-902 contains:

- ◆ (4) Dog Pt. Set Screws, M12-1.75 x 40 mm Lg.
- ◆ (1) O-Ring (#873)
- ◆ (1) Drill Bit, 10.2 mm Dia.
- ◆ (1) Tap, M12-1.75
- ◆ (1) Blue Loctite #242, .02 Fluid Oz.
- ◆ (1) Instruction Sheet #512-20P-001-00

Refer to Service Manual #502-11/20-001-00 for specific procedures and parts described in this Upgrade Instruction Sheet.

UPGRADE INSTRUCTION STEPS

Step 1

Remove the *Posidyne* and Gear Reducer from the Chopper Stand. See Section 7-1 and 7-2 in the Service Manual #502-11/20-001-00 for detailed instructions to remove the *Posidyne* Clutch/Brake, Fan, Fan Shroud and Flywheel.

Step 2

Drain the oil from the Gear Reducer. Save or discard as condition warrants.

Step 3

Remove the Breather (#45) from the *Posidyne* and replace it with a 3/8" pipe plug.

Step 4

Set the unit on the work bench with the Gear Reducer Shaft pointing up.

Step 5

Remove the (8) Screws (#843) and (8) Lockwashers (#850). Lift the Main Housing (#800) along with the Planet Hub (#886) straight up and off the Transfer Case (#801). Discard O-Ring (#873).

Step 6

Place the Main Housing (#800) on the work bench with the Gear Reducer Shaft in a horizontal position.

Step 7

Drive the Roll Pin (#879) into the Planet Gear Pin (#820) until it bottoms out as shown in *Figure 1*.

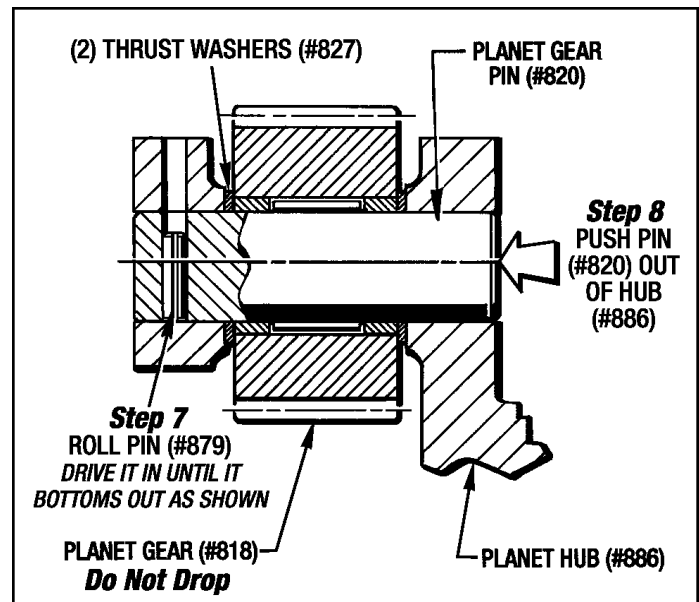

Figure 1 - Removing Roll Pin (#879)

Step 8

Push the Planet Gear Pin (#820) out of the Planet Hub (#886). **Be very careful not to allow the Planet Gear (#820) or the (2) Thrust Washers (#827) to drop when removing the Planet Gear Pin (#820). Have someone hold them as the Gear Pin is being removed.**

Step 9

Completely remove the Roll Pin (#879) from the Planet Gear Pin (#820).

Step 10

Repeat **Steps 6, 7 and 8** for the other (3) Planet Gear Pins (#820).

Step 11

Drill and tap the roll pin hole in the Planet Hub (#886) for either **English** or **Metric**. Be sure that you clean out all metal shavings from the Planet Hub (#886).

English: 27/64" Drill, 1/2'-13 Tap

Metric: 10.2 mm Drill, M12-1.75 Tap

Step 12

Install the Planet Gear Pin (#820), Planet Gear (#818) and (2) Thrust Washers (#827) into the Planet Hub (#886) as shown in *Figure 2*. Make sure the holes are aligned with each other.

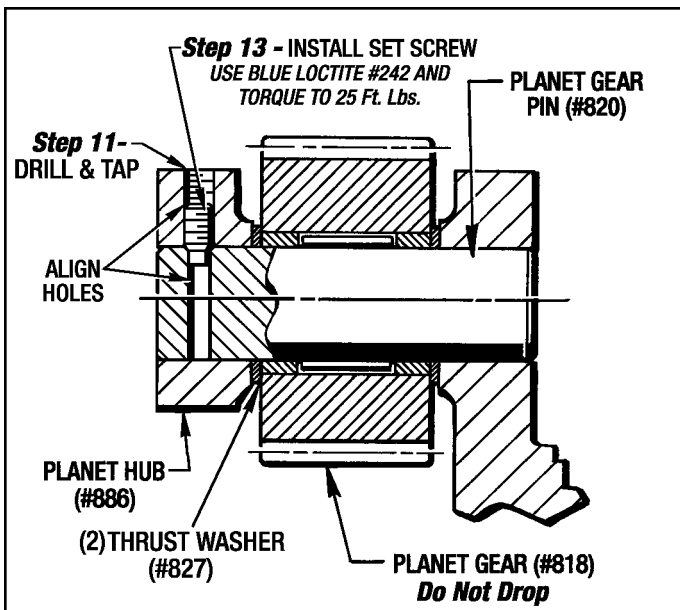

Figure 2 - Installing Set Screws

Step 13

Install the proper Dog Pt. Set Screw, using **Blue Loctite #242**. Torque to 25 Ft. Lbs.

Step 14

Repeat Steps 11, 12 and 13 for the other (3) Planet Gear Sets.

Step 15

After all (4) Planet Gear Pins (#820) and Planet Gears (#818) are properly installed, check the End Play of the Planet Hub (#886) as shown in *Figure 9.25* and described in **Section 9-14-C** in the **Service Manual #502-11/20-001-00**. Adjust if necessary.

Step 16

Check the Magnetic Encoder Housing for any build-up of insulation fibers. Clean out if necessary.

Step 17

Reassemble the Main Housing (#800) to the Transfer Case (#801) with the new O-Ring (#873) and the (8) Screws (#843) and (8) Lockwashers (#850). **Torque to 60 Ft. Lbs.** (Lubricate the new O-Ring with white grease before installing it.)

Step 18

Fill the Planetary Gear Reducer with oil as shown and described in **Section 4** in the **Service Manual #502-11/20-001-00**.

Step 19

Replace the Breather (#45) back into the *Posidyne* housing.

Step 20

Re-install the complete drive back on the Chopper frame as described in **Section 3 - Installation** in the **Service Manual #502-11/20-001-00**.



FORCE CONTROL INDUSTRIES, INC.

MAIN OFFICE & PLANT

P.O. Box 18366
Fairfield, Ohio 45018

3660 Dixie Highway
Fairfield, Ohio 45014

Tel: 513-868-0900
Fax: 513-868-2105

E-Mail: info@forcecontrol.com

Web: www.forcecontrol.com