



Posidyne X Class Clutch/Brake INSTALLATION MANUAL



MODELS & SIZES

This Installation Manual covers the Installation Procedure for the Posidyne Class X1, X2, X3 and X4 Clutch/Brakes. All (4) Sizes are available with "A" Logic, "C" Logic or "P" Logic.

- "A" Logic.....Air Set Clutch / Spring Set Brake
- "C" Logic.....Clutch Only
- "P" Logic.....Air Set Clutch / Air Set Brake

UNIT DESCRIPTION (See Figure 1)

In the Posidyne X Class Clutch/Brakes, the friction surfaces in both the Clutch Stack and Brake Stack consist of alternate carbon steel plates and advanced friction material on steel discs. The oil control grooves are molded into the friction material disc surfaces. The discs have internal teeth which mate with a spline on the output shaft for both clutch and brake applications. The steel plates are pinned to the input shaft in the clutch and the housing for the brake. The splined sections of the output shaft contains a centrifugal pumping system to maintain a positive flow of fluid between the discs and plates.

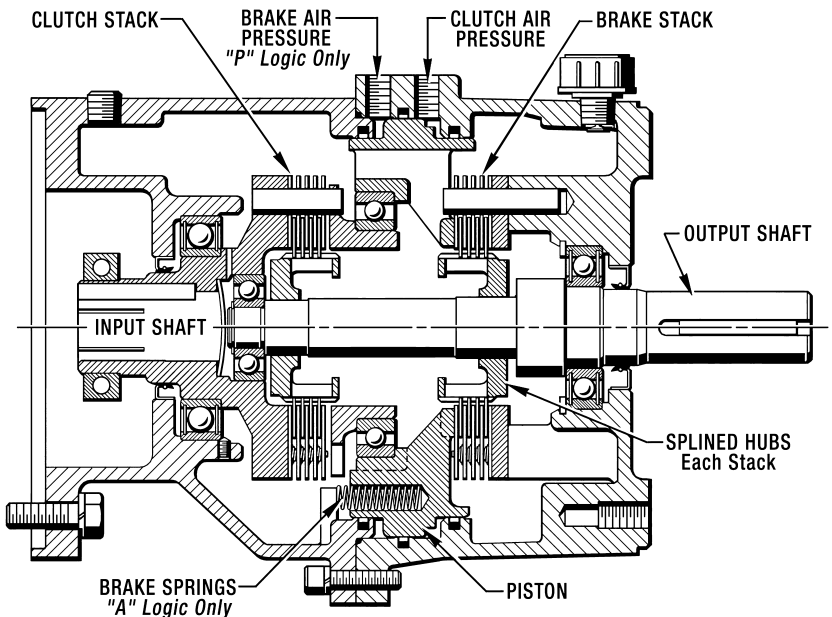
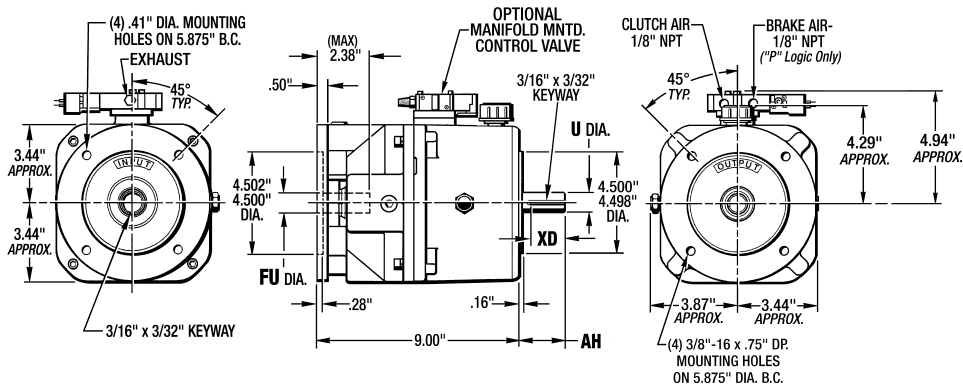

Figure 1 - Unit Description

Sizes X1 and X2

DIMENSIONS



UNIT SIZE	U	AH	XD	FU
X1	.6250 .6245	2.06	1.50	.6280 .6260
X2	.8750 .8745	2.12	1.75	.8780 .8760

Dimensions are in Inches.

Sizes X3 and X4

Dimensions are subject to change without notice. Certified Installation Drawings are available upon request.

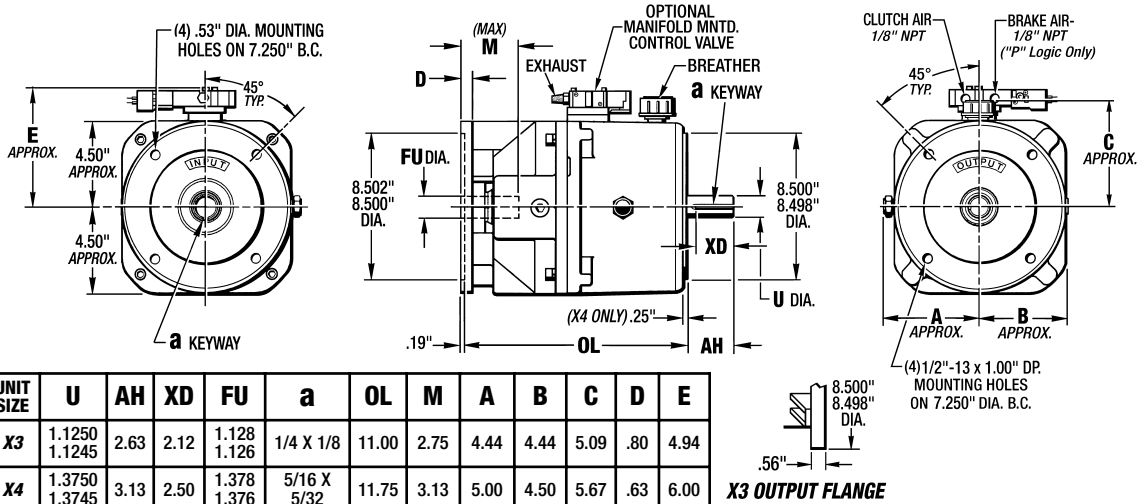

UNIT SIZE	U	AH	XD	FU	a	OL	M	A	B	C	D	E
X3	1.1250 1.1245	2.63	2.12	1.128 1.126	1/4 X 1/8	11.00	2.75	4.44	4.44	5.09	.80	4.94
X4	1.3750 1.3745	3.13	2.50	1.378 1.376	5/16 X 5/32	11.75	3.13	5.00	4.50	5.67	.63	6.00

Dimensions are in Inches.

Figure 2 - Dimensions

Force Control Industries, Inc.



MEX (55) 53 63 23 31 MTY (81) 83 54 10 18
QRO (442) 1 95 72 60 ventas@industrialmagza.com

OPERATING SPECIFICATIONS

SIZE & MODEL	LOGIC	CLUTCH TORQUE			BRAKE TORQUE			MAX RPM	AVG. THP			CYCLIC INERTIA (Lb. Ft. ²)	OIL CAPACITY (Oz.)			OVERHUNG LOAD CAP. (Lbs. Pull)
		STATIC (Lb. In.)	DYN. (Lb. In.)	AIR PR. (PSI)	STATIC (Lb. In.)	DYN. (Lb. In.)	AIR PR. (PSI)		HORIZ.	VIU	VID		HORIZ.	VIU	VID	
X1-2P2	P	110	95	60	110	95	60	1800	.40	.40	.40	.005	37	54	50	167
X1-2A2	A	90	77	80	49	42	----									
X1-2C2	C	99	85	70	----	----	----									
X2-3P3	P	220	189	60	220	189	60									
X2-3A3	A	179	154	80	98	84	----									
X2-3C3	C	198	170	70	----	----	----									
X3-4P4	P	512	440	70	512	440	70		.50	.40	.44	.006	53	59	74	464
X3-4A4	A	359	309	80	189	163	----									
X3-4C4	C	468	402	80	----	----	----									
X4-5P5	P	1039	894	60	1039	894	60		.41	.34	.34	.011	76	107	110	597
X4-5A5	A	777	668	80	444	382	----									
X4-5C5	C	1000	860	70	----	----	----									

NOTES: VIU = Vertical Input Up; VID = Vertical Input Down. * - Contact Force Control Factory.
 THP Ratings were developed under these parameters - 100° F Ambient Temperature & 220° F Maximum Oil Temperature.
 Overhung Load Capacity is based on Load at Midpoint of Shaft Extension.

INSTALLATION

A. Receiving the Posidyne Clutch/Brake

Check the *Posidyne* Clutch/Brake for shortages or damages immediately after arrival. Prompt reporting to the Carrier's Agent, with notations made on the Freight Bill, will expedite any adjustment made by the Carrier.

When unloading or handling the *Posidyne* Clutch/Brake, keep it upright. All Horizontal *Posidyne* drives are filled with oil, ready to run, when shipped. **Vertical Mounted Units will require additional fluid.** Before placing the *Posidyne* Clutch/Brake in service or storage, check the fluid level to make sure none has spilled out in transit. Add fluid if necessary. Refer to *Page 4*.

Remove the red plastic pipe plug from the top of the Output Housing and install the Air Breather (#45). Failure to install this Air Breather (#45) can cause serious damage to the drive unit and will void the warranty.

Note - There are some pipe fittings supplied for Vertical Mounting. This is used for the Air Breather as shown in *Figure 5*.

If the *Posidyne* Clutch/Brake is not to be installed or operated soon after arrival, store it in a clean dry place having a slow and moderate change in ambient temperature.

B. Mounting the Posidyne Clutch/Brake

(See *Figure 3*)

1. First make sure that the pilot diameter and mating surfaces of the C-Face Flange is clean and free of all nicks, burrs or anything that would not allow the *Posidyne* Clutch/Brake to seat properly.
2. Loosely install the Locking Collar (#281) in position on the Input shaft (#2) with the split in the collar aligned with the split in the quill shaft as shown in *Figure 3*. **Do not tighten the screws yet.**
3. Remove the drive motor key if there is one on the motor shaft and install Key (#180), which is supplied with the *Posidyne* Clutch/Brake.

IMPORTANT - Make sure that the motor shaft is thoroughly cleaned but do not lubricate the shaft with any oil. Torque transfer depends on friction between the motor shaft and the split quill input shaft.

4. Slip the *Posidyne* Clutch/Brake onto the motor shaft with the Key (#180) aligned with the keyway in the Input Shaft (#2). Push the Drive Unit until it seats on the motor pilot diameter.

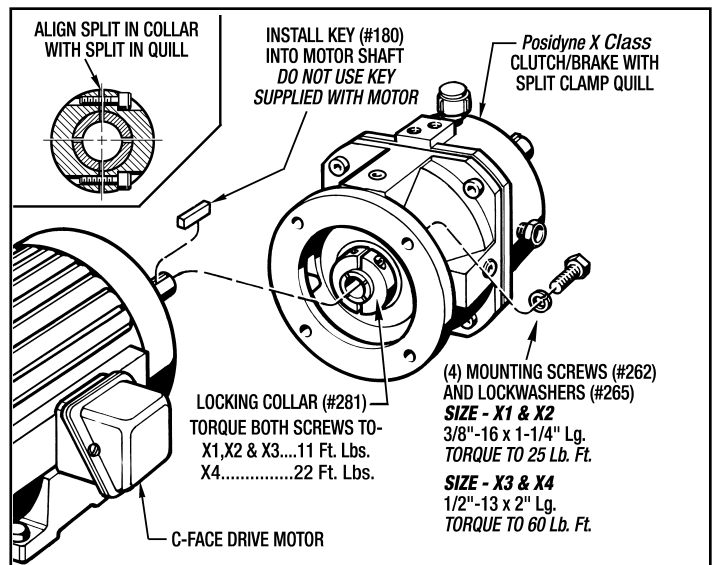

Figure 3 - Mounting The Posidyne Clutch/Brake

5. Attach the *Posidyne* Clutch/Brake with the (4) Hex Hd. Screws (#262) and (4) Lockwashers (#265). **On Sizes X1 and X2 the torque is 25 Lb. Ft. (300 Lb. In.)** Sizes X3 and X4 requires **60 Lb. Ft. (720 Lb. In.)** of torque.

Visually check to see if the C Face mounting surfaces are snug and tight all the way around.

6. Torque the (2) Screws in the Locking Collar (#281) to **11 Ft. Lbs. (132 In. Lbs.)** for X1, X2 & X3. **22 Ft. Lbs. (264 In. Lbs.)** for X4.

C. Pneumatic Hookup

Figure 4 shows the pneumatic control valves and pneumatic diagrams for the *X Class Posidyne* Clutch/Brake Unit.

Note the following when planning and installing the air system:

1. Use direct acting solenoid air valves or pilot operated valves to give the response speed required. Locate the remote mounted valves as close as possible to the air inlets on the *Posidyne* Clutch/Brake.

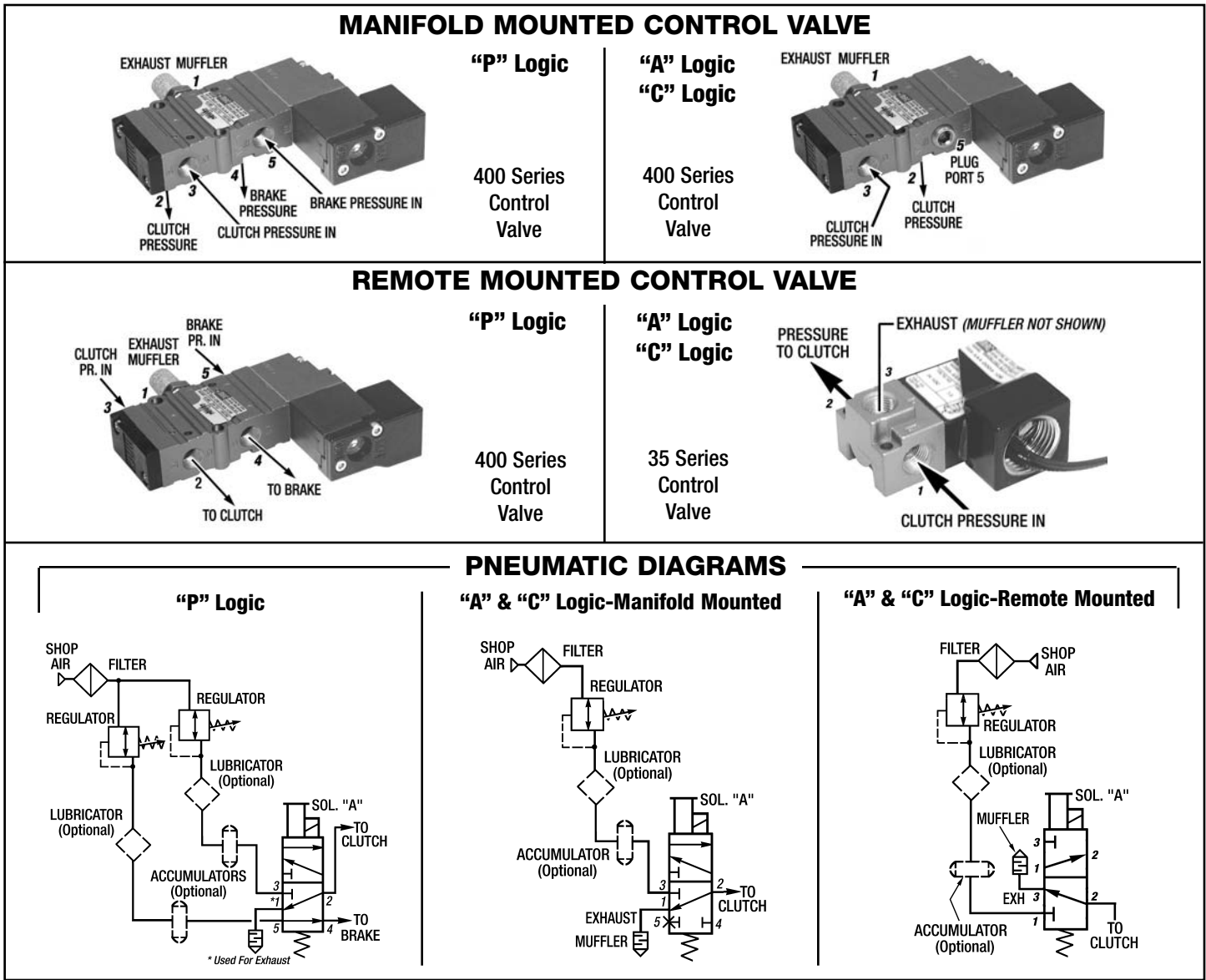

Figure 4 - Pneumatic Control Valves and Diagrams

- The optional accumulator should be used for quick response, particularly if the air line loss and the nature of the air supply is such that recovery is slow. Size the accumulator to be at least 10 times the air required per engagement.
- A small amount of oil in the air supply may prolong the life of the pneumatic control valve, but too much oil will fill the *Posidyne* Clutch/Brake piston chamber with oil and make the actuation sluggish.
No oil in the air supply is better than too much oil in the air supply.
- The air pressure regulator should be sized and set to provide the required torque. (See *Torque Specifications Chart for Max. Air Pressure.*)
- Pressure is directly proportional to torque. **60 PSI** is the maximum pressure for **"P" Logic** for Sizes X1, X2 & X4, **70 PSI** for **"P" Logic** on Size X3 and **80 PSI** is the maximum pressure for **"A" & "C" Logic** on all sizes. Use only the air pressure necessary. This will give additional life to the Clutch/Brake Unit.

NOTE: Use 3/16" I.D. tubing or hoses for remote installation on Sizes X1, X2 and X3 *Posidyne*. Use 1/4" I.D. tubing or hoses for remote installation on Size X4 *Posidyne*. See complete *Service Manual* for control valve dimensions.

LUBRICATION

A. Checking the Fluid Level

When the *Posidyne* Clutch/Brake is installed and weekly thereafter, or until experience dictates otherwise, check the fluid level. Always check the fluid level with the drive at room temperature and while it is not running.

The *Posidyne* Clutch/Brake has a fluid sight gauge located on the side of the *Posidyne* Clutch/Brake. The fluid level is to show at the center of the gauge.

B. Changing the Fluid

(See Figure 5)

IMPORTANT : Open the disconnects to the drive motors before attempting to change the fluid.

After the first 30 days of operation completely drain the fluid from the drive using the drain plugs provided. If the fluid sight glass is dirty it should be removed and cleaned.

Reinstall the drain plugs and refill the drive to the center of the sight glass with fresh fluid.

On vertical mounted *Posidyne* Clutch/Brakes, also remove the top Pipe Plug (#92) to act as a vent when filling with fluid. Replace when filled.

After the first fluid change check the fluid level and color of the fluid at least once per month. Maintain the fluid level to the center of the sight glass by adding additional fluid as needed. The fluid should be

changed after every 12 months of operation or sooner if the fluid color darkens. High energy applications, high cycle rates and extremely dirty environments will darken the color of the fluid.

CAUTION: Do not overfill the Drive Unit. Excess fluid will cause the unit to overheat.

C. Type of Fluid

Use only Mobil Automatic Transmission Fluid ATF-210 (Type F) or Mobil Multi-purpose Automatic Transmission Fluid for all drives. **Always use the type of fluid specified on the Name Plate.**

For Washdown and/or Food Processing Applications use **Mobil Synthetic ATF Fluid.**

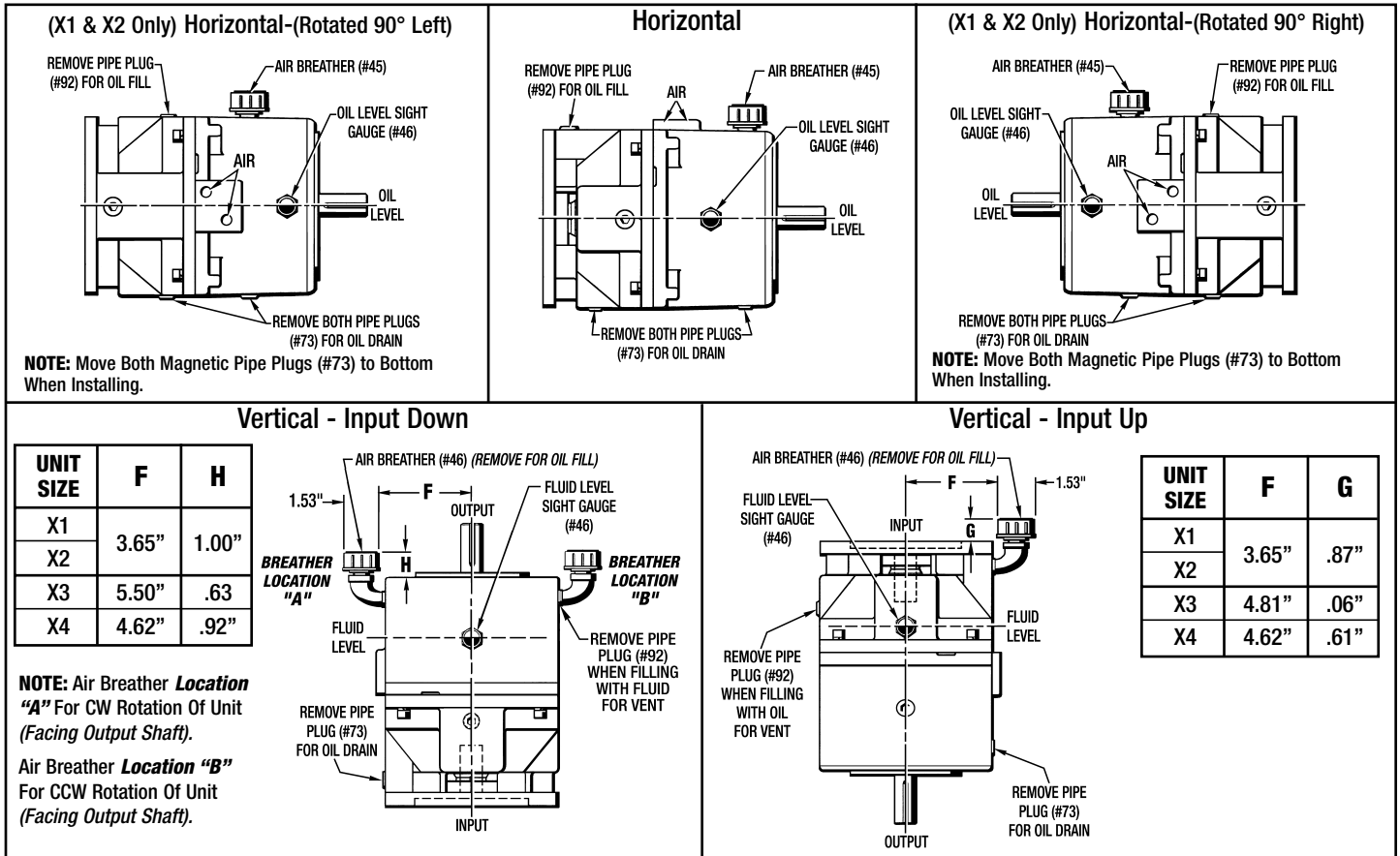

Figure 5 - Lubrication

FACTORY REBUILD SERVICE MAINTENANCE & SERVICE MANUALS

A. FACTORY REBUILD SERVICE

A **Factory Rebuild Service** is offered by Force Control Industries, Inc. Contact our service and sales department at Force Control for additional information.

B. MAINTENANCE & SERVICE MANUALS

A complete **Service Manual** can be downloaded and printed off of our website for **Maintenance Procedures and Repair Parts. Go to:**

www.forcecontrol.com

All of our Catalogs and Service Manuals on the web site are in PDF format and will require Adobe Acrobat Reader 5.0 or later to open them. This Adobe Acrobat Reader 5.0 can be downloaded from our web site if you do not have it installed on your computer.



FORCE CONTROL INDUSTRIES, INC.

3660 Dixie Highway
 Fairfield, Ohio 45014

Phone: 513-868-0900

Fax: 513-868-2105

E-Mail: info@forcecontrol.com

Web Site: www.forcecontrol.com

