

MAINTENANCE, FACTORY REBUILD SERVICE & REPAIR PARTS

A Factory Rebuild Service is offered by Force Control Industries, Inc. Contact our service and sales department at Force Control for additional information.

A complete Service Manual can be downloaded and printed off of our website. Go to:

www.forcecontrol.com

All of our Catalogs and Service Manuals on the web site are in PDF format and will require Adobe Acrobat Reader 4.0 or later to open them. This Adobe Acrobat Reader 4.0 can be downloaded from our web site if you do not have it installed on your computer.



FORCE CONTROL INDUSTRIES, INC.

3660 Dixie Highway
Fairfield, Ohio 45014

Phone: 513-868-0900

Fax: 513-868-2105

E-Mail: info@forcecontrol.com

Web Site: www.forcecontrol.com



MEX (55) 53 63 23 31 MTY (81) 83 54 10 18
QRO (442) 1 95 72 60 ventas@industrialmagza.com



Posidyne X Class Clutch/Brake INSTALLATION MANUAL



MALE INPUT SHAFT ADAPTER KIT & MOUNTING FOOT KIT

This Installation Manual covers the Installation Procedure for:

1. Male Input Shaft Adapter Kit
2. Mounting Foot Kit

These kits are optional equipment for all sizes of the *Posidyne* X Class Clutch/Brakes Drives.

These sizes are X1, X2, X3 & X4.

Size X1 and X2 Posidyne Clutch/Brake

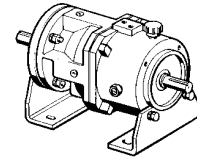

Size X3 and X4 Posidyne Clutch/Brake

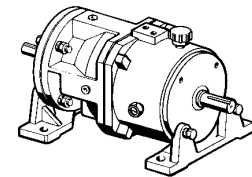

DIMENSIONS

Size X1 and X2

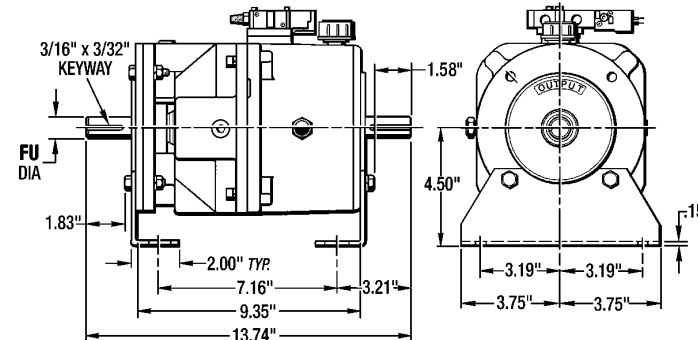

	X1	X2
FU DIA	.6250"	.8750"
DIA	.6245"	.8745"

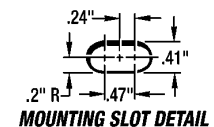

Size X3 and X4

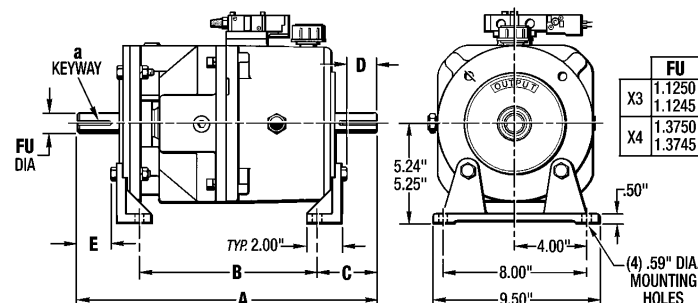

	FU	a	A	B	C	D	E
X3	1.1250	1/8 x 1/4	17.00	9.50	3.63	2.00	2.20
	1.1245						
X4	1.3750	5/16 x 5/32	18.62	10.25	4.13	2.36	2.62
	1.3745						

INSTALLATION

1. Insert the Male Input Shaft into the Split Quill. Attach the Adapter Plate and Mounting Feet to the unit as shown in *Figures 1 and 2*.
2. Torque the (4) Mounting Bolts and Nuts to **25 Lb. Ft.** for Sizes X1 & X2 and **60 Lb. Ft.** for Sizes X3 & X4.
3. Make sure the Locking Collar (#281) is flush with the rear surface of the Split Quill and the splits in the Locking Collar are aligned with the splits in the Split Quill as shown in *Figure 1*. Torque the (2) Screws in the Locking Collar as follows:

(X1, X2 and X3).....**11 Ft. Lbs. (132 In. Lbs.)**
 (X4).....**22 Ft. Lbs. (264 In. Lbs.)**

4. The Drive should be mounted on a firm, level base or foundation, common with both the driving and driven components. Use SAE Grade 5 Hex Hd. Cap Screws to bolt the drive securely into place. Before tightening down the bolts, check alignment with both the driving and driven machinery, then recheck after tightening.
5. If the input or output shaft is to be directly coupled, use only a flexible coupling (with horsepower service factor 3 to 1) to take care of maximum torque requirements. Make sure that the shafts to be coupled are concentric within 0.005 in. TIR. Check for horizontal, vertical and angular misalignment. Use shims as necessary to correct.

CAUTION:

Do not drive couplings or bushings on shaft.

6. If the Drive is to be connected through a belt, chain or gear drive, locate as close as possible to the housing to minimize overhung loads. Make sure that the sheaves, sprockets or gears are in line and that the shafts are parallel.
7. After the machinery has been in operation for a few hours, make sure that all mounting bolts are tight and recheck the alignment of all components.
8. After machinery has been in operation for 40 hours check the mounting bolts and tighten if necessary.

Male Input Adapter Kit

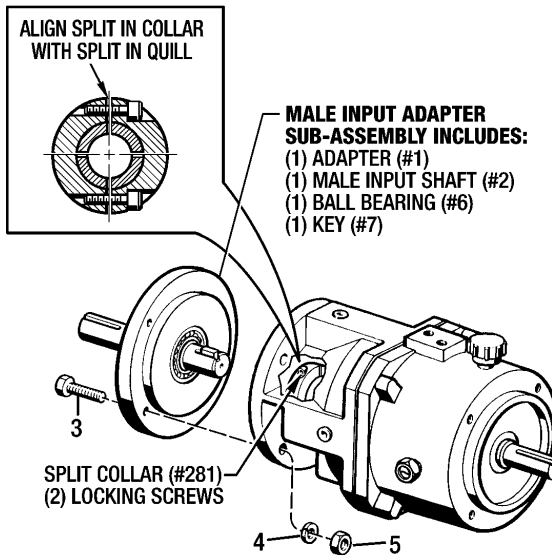

Figure 1 - Male Input Adapter Kit

Overhung Load Capacity @ Midpoint of Shaft:	
X1.....	152 Lbs.
X2.....	152 Lbs.
X3.....	435 Lbs.
X4.....	459 Lbs.

REF. No.	PART NAME	QTY.
1	Input Adapter	1
2	Male Input Shaft	1
3	Hex Hd. Screw (X1 & X2) 3/8"-16 x 1-1/2" Lg.	4
	(X3 & X4) 1/2"-13 x 2-1/4" Lg.	4
4	Hex Nut (X1 & X2) 3/8"-16	4
	(X3 & X4) 1/2"-13	4
5	Lockwasher (X1 & X4) 3/8"	4
	(X3 & X4) 1/2"	4
6	Bearing	1
7	Key (X1 & X2) 3/16" Sq. x 3/4" Lg.	1
	(X3) 1/4" Sq. x 1-1/2" Lg.	1
	(X4) 5/16" Sq. x 1-1/2" Lg.	1

To order a complete Male Input Adapter Kit use the following Part Numbers:

- X1 Posidyne #02-X1-IA-KIT
- X2 Posidyne #02-X2-IA-KIT
- X3 Posidyne #02-X3-IA-KIT
- X4 Posidyne #02-X4-IA-KIT

Add a "W" after **KIT** for Washdown duty & an "E" for White Epoxy Paint . **Examples - #02-X1-IA-KITW; #02-X1-IA-KITE**

Foot Mounting Kit

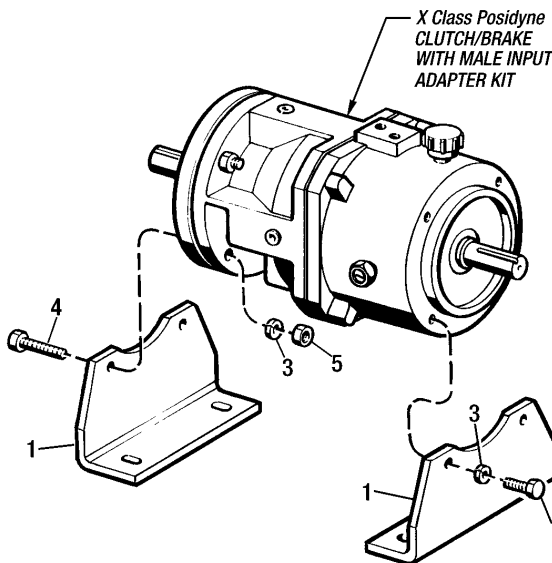

Figure 2 - Foot Mounting Kit

REF. No.	PART NAME	QTY.
1	Foot Bracket	2
2	Hex Hd. Screw (X1 & X2) 3/8"-16 x 3/4" Lg.	2
	(X3 & X4) 1/2"-13 x 1-1/4" Lg.	2
3	Lockwasher (X1 & X2) 3/8"	4
	(X3 & X4) 1/2"	4
4	Hex Hd. Screw (X1 & X2) 3/8"-16 x 1-1/2" Lg.	2
	(X3 & X4) 1/2"-13 x 2-1/4" Lg.	2
5	Hex Nut (X1 & X2) 3/8"-16	2
	(X3 & X4) 1/2"-13	2

To order a complete Foot Mounting Kit use the following Part Numbers:

- X1 & X2 Posidyne #02-X1-FT-KIT
- X3 & X4 Posidyne #02-X4-FT-KIT

NOTES - This Foot Mounting Kit cannot be used on these Posidyne Units without the Male Input Adapter Kit. Add a "W" after **KIT** for Washdown duty & an "E" for White Epoxy Paint . **Examples - #02-X1-IA-KITW; #02-X1-IA-KITE**