

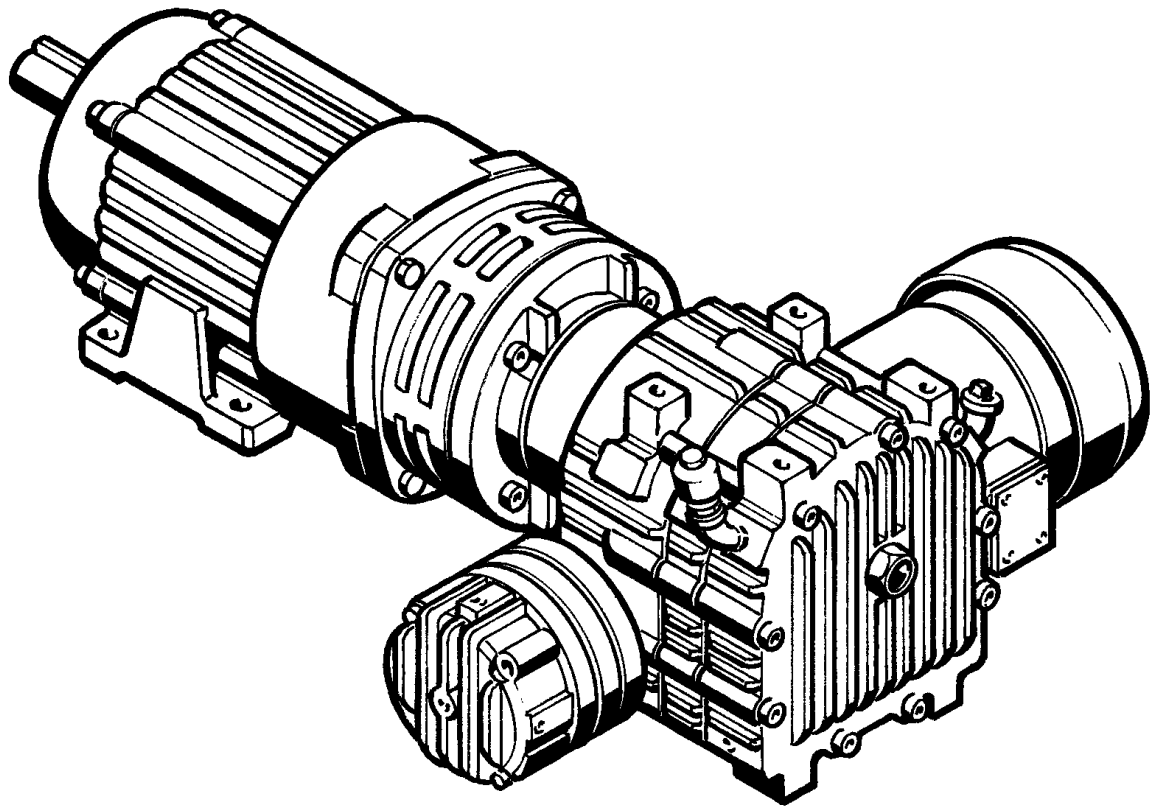

502-T3-001-01

SERVICE MANUAL AND REPAIR PARTS FOR *TWO SPEED DRIVE III (TSDr III)*



WARNING - Read this manual before any installation, maintenance or operation.



FORCE CONTROL INDUSTRIES, Inc.

**MANUFACTURERS OF MECHANICAL AND
ELECTRICAL POWER TRANSMISSION EQUIPMENT**



MEX (55) 53 63 23 31 MTY (81) 83 54 10 18
QRO (442) 1 95 72 60 ventas@industrialmagza.com

LIMITED WARRANTY

SPECIAL 24 MONTH WARRANTY

Upon written approval of the application by Force Control Industries, Inc. the Standard Warranty period will be extended to 24 months.

Force Control Industries, Inc. ("Force Control") warrants its products to be free from defects in material and workmanship under normal and proper use for a period of one year from the date of shipment. Any products purchased from Force Control that upon inspection at Force Control's factory prove to be defective as a result of normal use during the one year period will be repaired or replaced (at Force Controls' option) without any charge for parts or labor. This limited warranty shall be void in regard to (1) any product or part thereof which has been altered or repaired by a buyer without Force Control's previous written consent or (2) any product or part thereof that has been subjected to unusual electrical, physical or mechanical stress, or upon which the original identification marks have been removed or altered. Transportation charges for shipping any product or part thereof that the buyer claims is covered by this limited warranty shall be paid by the buyer. If Force Control determines that any product or part thereof should be repaired or replaced under the terms of this limited warranty it will pay for shipping the repaired or replaced product or part thereof back to the buyer. EXCEPT FOR THE EXPRESS WARRANTY SET OUT ABOVE, FORCE CONTROL DOES NOT GRANT ANY WARRANTIES EITHER EXPRESSED OR IMPLIED, INCLUDING IMPLIED WARRANTIES OF MERCHANTABILITY OR FITNESS FOR USE. The warranty obligation set forth above is in lieu of all obligations or liabilities of Force Control for any damages. Force Control specifically shall not be liable for any costs incurred by the buyer in disconnecting or re-installing any product or part thereof repaired or replace under the limited warranty set out above. FORCE CONTROL EXPRESSLY EXCLUDES ALL LIABILITY FOR ANY INDIRECT OR CONSEQUENTIAL DAMAGES THE BUYER MAY SUSTAIN IN CONNECTION WITH THE DELIVERY, USE, OR PERFORMANCE OF FORCE CONTROL PRODUCTS. Under no circumstances shall any liability for which Force Control is held responsible exceed the selling price to the buyer of the Force Control products that are proven to be defective. This limited warranty may be modified only in writing signed by a duly authorized officer of the company. This limited warranty applies exclusively to Force Control products; warranties for motors and gear reducers and other component parts may be provided by their respective manufactures. Any legal action for breach of any Force Control warranty must be commenced within one year of the date on which the breach is or should have been discovered.

A Return Goods Authorization (RGA) number must be obtained from the factory and clearly marked on the outside of the package before any equipment will be accepted for warranty work. Force Control will pay the shipping costs of returning the owner parts that are covered by warranty.

Force Control believes that the information in this document is accurate. The document has been carefully reviewed for technical accuracy. In the event that technical or typographical errors exist, Force Control reserves the right to make changes to subsequent editions of this document without prior notice to holders of this edition. The reader should consult Force Control if errors are suspected. In no event shall Force Control be liable for any damages arising out of or related to this document or the information contained in it.

FORCE CONTROL INDUSTRIES, INC.



MEX (55) 53 63 23 31 MTY (81) 83 54 10 18
QRO (442) 1 95 72 60 ventas@industrialmagza.com



TABLE OF CONTENTS

Section 1 - DESCRIPTION and OPERATION		Section 7 - REPAIR and REPLACEMENT			
1-1	MODULE DESCRIPTION	1	7-1	GENERAL INFORMATION.....	11
	Item A. Main Drive Motor	1	7-2	REPLACING CLUTCH STACK & PISTON SEALS	11
	Item B. Main Drive Motor C-Face Adapter	1		A. Disassembly Procedure	11
	Item C. TSDr III Clutch/Brake.....	1		B. Reassembly Procedure	12
	Item D. Feed Motor Drive	1	7-3	REPLACING BRAKE STACK & PISTON SEALS	13
	Item E. Feed Drive Motor	2		A. Disassembly Procedure	13
1-2	THE OIL SHEAR PRINCIPLE	2		B. Reassembly Procedure	13
1-3	CLUTCH/BRAKE DESCRIPTION	2	7-4	REPLACING WORM SHAFT OIL SEAL (#64)	
1-4	CLUTCH/BRAKE OPERATION	2		(With Quill Worm Shaft).....	14
Section 2 - SPECIFICATIONS			7-5	REPLACING WEAR SLEEVE (#68)	
	Clutch Torque Rating Options	4		(With Quill Worm Shaft).....	15
	Performance Specifications	4	7-6	REPLACING WORM SHAFT OIL SEAL (#63)	
				(With Male Worm Shaft)	16
Section 3 - INSTALLATION and START-UP			7-7	REPLACING WEAR SLEEVE (#69)	
	IMPORTANT SAFETY PRECAUTIONS	5		(With Male Worm Shaft)	16
3-1	RECEIVING THE <i>TSDr III</i> DRIVE.....	5	7-8	REPLACING WEAR SLEEVE (#67)	
3-2	MOUNTING THE <i>TSDr III</i> DRIVE	5		AND OIL SEAL (#62)	18
3-3	WIRING SPECIFICATIONS	5		A. Disassembly Procedure	18
3-4	PNEUMATICS	5		B. Replacing Wear Sleeve (#67)	18
3-5	START-UP	5		C. Replacing Oil Seal (#62)	18
				D. Reassembly Procedure	18
Section 4 - LUBRICATION			Section 8 - ILLUSTRATED PARTS LIST		
4-1	CHECKING THE OIL LEVEL	6	8-1	GENERAL INFORMATION.....	19
4-2	OPERATING TEMPERATURES	6	8-2	DRIVE MOTORS.....	19
	A. Ambient Temperatures.....	6	8-3	FACTORY REBUILD SERVICE	19
	B. Oil Sump Temperature	6	8-4	ORDERING REPLACEMENT PARTS	19
4-3	CHANGING THE OIL.....	6	8-5	NAME PLATE AND MODEL NUMBER	20
4-4	TYPE OF OIL	6		INCHING MOTOR ASSEMBLY CONFIGURATIONS.....	21
Section 5 - OPERATIONAL CHECKS			REPAIR PARTS		
5-1	CLUTCH/BRAKE OPERATION	7		Repair Parts List - Figure 8.1	22
5-2	DRIVE MOTORS.....	7		Figure 8.1 - Main Housing and Clutch Stack	23
5-3	PNEUMATIC CONTROL	7		Repair Parts List - Figures 8.2 & 8.3.....	24
				Figure 8.2 - Secondary Worm Shaft	24
				Figure 8.3 - Brake Assembly	25
Section 6 - TROUBLE SHOOTING					
6-1	TROUBLE SHOOTING CHART	8			
6-2	MEASURING STACK HEIGHT	10			
6-3	PNEUMATIC SCHEMATIC.....	10			

Section 1

DESCRIPTION and OPERATION

The **Force Control Two Speed Drive III (TSDr III)** is built from five separate modules. Each module offers several choices, making a complete unit essentially tailor made specifically for each application.

1-1 MODULE DESCRIPTION

(See Figures 1.1 and 1.2)

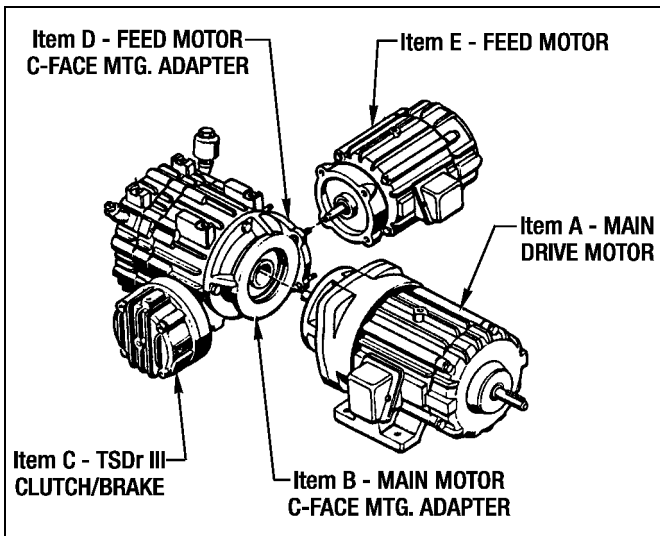

Figure 1.1 - C-Face Mounted Feed Motor

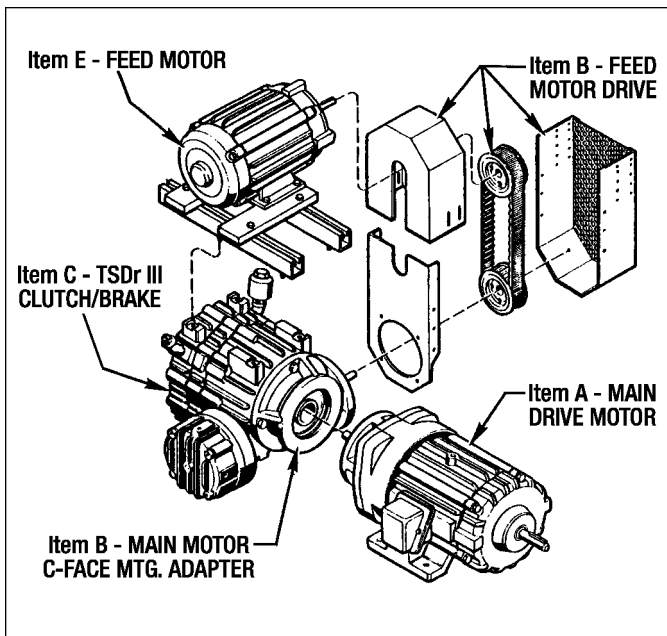

Figure 1.2 - Foot Mounted Feed Motor

Item A - MAIN DRIVE MOTOR

The **High Speed Main Drive Motor** provides acceleration and running torque to the driven machinery. U-Line motors are normally used, while others are available for special applications. The most common base speeds of the main drive motor is 1200 RPM or 1800 RPM. Horsepowers are available from 10 HP to 30 HP. All motors are supplied TEFC unless otherwise specified.

Item B - MAIN DRIVE MOTOR C-FACE MOUNTING ADAPTER

The **C-Face Adapter**, as shown in Figures 1.1 and 1.2, connects the main housing of the **TSDr III** to the main drive motor. It is mounted to the main drive motor with a standard NEMA C-Face Pilot. The adapter is available with a 10-1/2" FAK or 12-1/2" FAK pilot diameter.

Item C - TSDr III CLUTCH/BRAKE

As noted above, the **TSDr III** is mounted to the main drive motor with a C-Face Adapter. Torque is transmitted from the motor to the drive by mating the accessory shaft of the main motor with a female hub in the drive. The motor shaft is locked to the hub with a keyless tapered locking element.

The **TSDr III Clutch/Brake** is a spring set and air release type unit. This means if there is no air supplied to the drive, by the control valve or because of power failure, the clutch and brake will be set by spring pressure. To release the clutch and/or the brake, air pressure must be supplied to the clutch and/or the brake port. See **Section 1-4 Clutch and Brake Operation**.

The **TSDr III** has a built in gear reducer. This offers the advantage of being more compact and easier to maintain than a drive with an external bolt-on gear reducer. The gear reducer is a worm and gear type and runs in the same oil as the clutch stack.

Item D - FEED MOTOR DRIVE

The **Feed Drive Motor** can be C-Face mounted to the drive as shown in Figure 1.1 or foot mounted as shown in Figure 1.2. If the Feed Motor is foot mounted, the ratio of the belt drive can be varied. By varying the belt drive ratio along with the gear reducer ratio, a wide range of Feed Speeds are available. Speeds from 360 RPM down to 23 RPM are possible by using different combinations of gear reducer and belt drive ratios. A synchronous belt drive is used for a positive transmis-

sion of motor torque to the drive. (See Model Number Information in Section 8 for all available feed speeds.) Different mounting arrangements are available to suit different space requirements. **Consult factory for Belt Drive Mounting Arrangements and Certified Installation Drawings.**

The Feed Drive Motor can also be C-Face mounted to the **TSDr III**. The motor is attached to the drive with a C-Face Adapter that uses a NEMA C-Face pilot diameter of 4-1/2" AK or 8-1/2" AK. The shaft of the feed motor mates with a keyed female shaft in the drive to transmit torque to the **TSDr III**. However, the range of different feed speeds is limited with this arrangement. Only the gear reducer ratio can be changed to obtain different feed speeds. The range is from 23 RPM to 360 RPM. (See Model Number Information in Section 8 for all available feed speeds.)

NOTE: The C-Face arrangement cannot be used for applications that downshift from high to low speed.

Item E - FEED MOTOR

The Feed Drive Motor is either foot mounted or C-Face mounted to the **TSDr III**. Standard feed drive motors are 1200 RPM or 1800 RPM and range from 1-1/2 to 3 HP.

1-2 The OIL SHEAR PRINCIPLE

Conventional clutches and brakes depend on the friction between solid surfaces operating in air to transmit torque. Friction does the job but produces a great amount of heat and wear. The **Two Speed Drive III** is an *Oil Shear Drive*, with the friction surfaces operating in a constantly replenished film of oil. The oil molecules tend to cling to each other and to the friction surfaces. As moving and stationary elements are brought together, a thin but positive film of oil is maintained between them which is controlled by the clamping pressure and carefully designed grooves in the friction discs. Torque is transmitted from one element to the other through the viscous shear of the oil film. As long as there is relative motion between the elements, they are protected by the oil, thus greatly reducing wear. The replenished oil film also effectively transmits heat away from the friction elements.

1-3 CLUTCH AND BRAKE DESCRIPTION

In the **TSDr III Clutch/Brake**, the friction surfaces consists of alternate carbon steel plates called Drive Plates and Friction Discs. The Friction Discs have an advanced resilient paper based friction material bonded to steel discs. The oil control grooves are machined into the friction material on the friction discs. The friction discs have

internal spline teeth which mates with the spline on the hubs for both clutch and brake applications. The steel drive plates are keyed to the input shaft for the clutch and to the housing for the brake. The splined sections of the hubs contains centrifugal impellers to maintain a positive flow of oil between the friction discs and drive plates.

1-4 CLUTCH/BRAKE OPERATION

(See Figure 1.3)

The **TSDr III Clutch and Brake** cross section in Figure 1.3 shows the drive in the off position with the clutch and brake engaged. This is the normal position when air pressure or electrical services are turned off.

Springs are used to force the brake piston against the brake stack. The force of the piston is great enough to lock the disc pack solid which in turn keeps the worm shaft and the input shaft from turning. The clutch works in the same manner except its purpose is to couple and uncouple the input shaft to the hub. With both the clutch and brake engaged, the input shaft is coupled to the hub and neither one is free to turn.

The main drive motor is coupled to the hub and with the **TSDr III** in the off position it is not free to run. To run, air pressure is applied to the clutch port. The air pressure overcomes the spring pressure to move the piston away from the clutch stack. With the clutch stack unclamped, the hub is uncoupled from the input shaft allowing the main drive motor to run freely. To stop the main drive motor the brake is left engaged and air is exhausted from the clutch port. The clutch piston is then forced by springs to clamp the clutch stack. This again couples the hub to the input shaft, which is locked by the brake, thus stopping the main drive motor.

To run the feed drive motor, the main drive motor is brought to a stop or near stop as described above. Air is applied to the brake port to overcome the spring pressure and move the piston away from the brake stack. With the brake stack released, the feed motor is free to run the worm shaft. Torque is transmitted from the worm shaft to the worm gear to the input shaft. Since the clutch stack is clamped, torque is transmitted from the input shaft, through the clutch stack to the hub and out to the main drive motor. This would complete a full cycle.

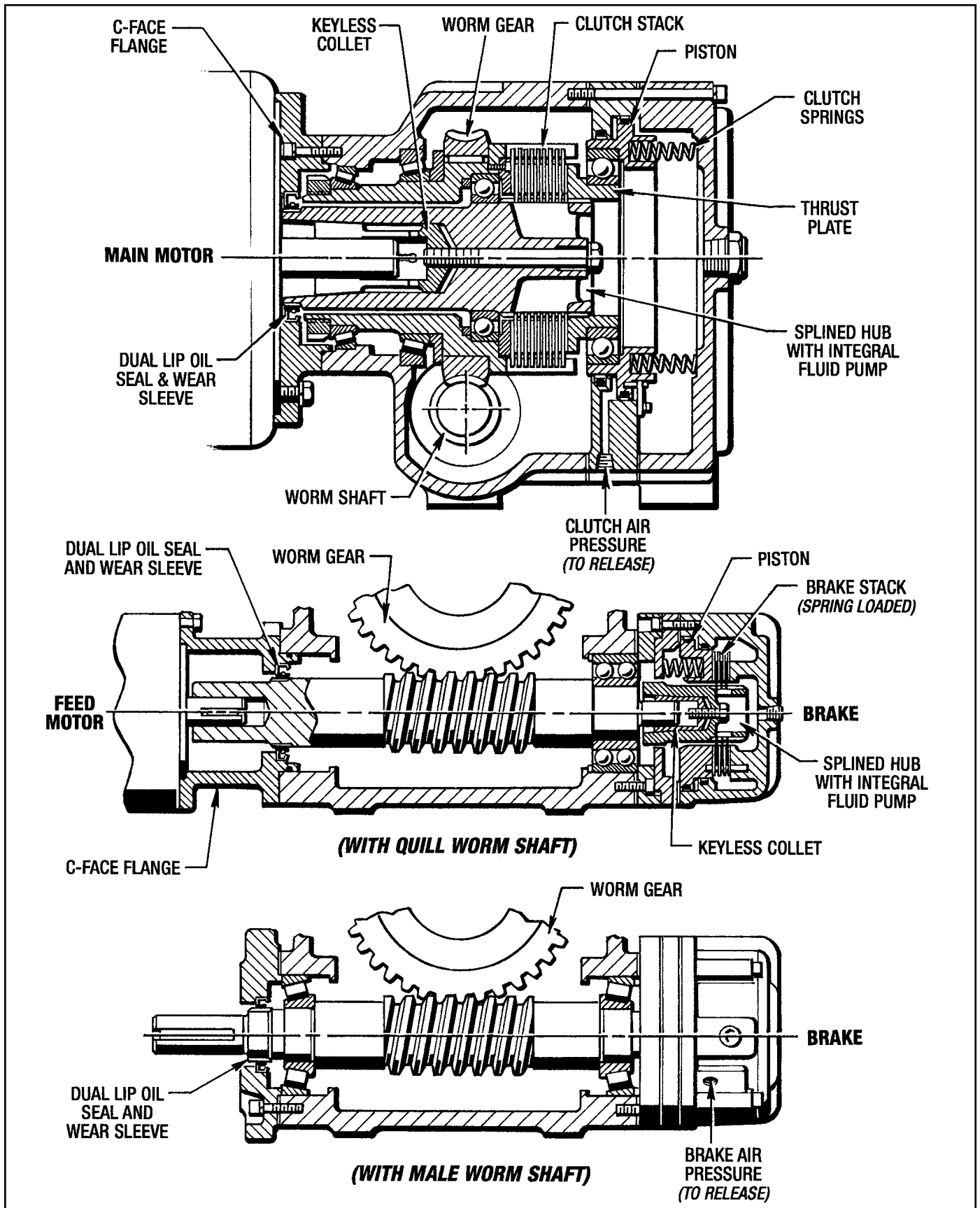

Figure 1.3 - Two Speed Drive III Cross Section

FORCE CONTROL INDUSTRIES, INC.



MEX (55) 53 63 23 31 MTY (81) 83 54 10 18
 QRO (442) 1 95 72 60 ventas@industrialmagza.com

Section 2 SPECIFICATIONS

CLUTCH TORQUE RATING OPTIONS

Torque (Ft. Lbs.)	Spring (#83) Qty.	Spring (#83) Type/Color	Release Pressure
126	3	Med./Blue	13 PSI
168	4		18 PSI
252	6		26 PSI
323	3	Heavy/Red	34 PSI
335	8	Med./Blue	35 PSI
430	4	Heavy/Red	45 PSI
646	6		60 PSI

All Torque Ratings are with (9) Drive Plates and (9) Friction Discs. Consult factory for other available Torque Ratings.

Brake Release Pressure 60 PSI

Two Speed Drive (TSDr III) Performance Specifications

Two Speed Drive Type III Performance Specifications, with normal efficiency U-Frame Motor. (U7EQ, EM1 or NPEM 100)

Main Motor				Total Drive Cyclic Inertia (Lb. Ft. ²)	Drive No Load Starts Per Min.	Calculated Spring Set Clutch Torque (Lb. Ft.)	Suggested Inching Motor HP
HP	RPM	Motor Frame	Cyclic Inertia (Lb. Ft. ²)				
10	1200	284U	3.83	4.14	13	168	1.5
15	1200	324U	6.90	7.21	7	252	2
20	1200	326U	8.60	8.91	5	323	3
25	1200	364U	10.7	11.01	6	335	3
15	1800	284U	1.90	2.21	8	168	2
20	1800	286U	3.00	3.31	7	252	2
25	1800	324U	4.50	4.81	6	252	3
30	1800	326U	5.90	6.21	5	323	3

* Drive will be shipped with this torque unless otherwise specified on the order.

** The clutch torque also dictates the drive braking torque.

To determine the Starts per Minute capability of the Two Speed Drive when installed, use the following formula:

$$S/M1 = \frac{WK_D^2}{WK_D^2 + WK_L^2} \times S/M$$

S/M1 = Starts per Minute capability of Installed Drive.

WK_D^2 = Inertia of Two Speed Drive from Table.

WK_L^2 = Inertia of driven load reflected to Two Speed Drive.

S/M = No load starts per minute rating from Table.

Section 3

INSTALLATION and START-UP

IMPORTANT SAFETY PRECAUTIONS

The *Two Speed Drive III (TSDr III)* units described in this manual must not be installed in any manner except as specified and must not be operated at speeds, horsepower loads or temperatures other than those specified in this manual.

Failure to limit the operation of the drive to the conditions specified could damage the unit or damage interconnected equipment and void the Warranty.

Suitable guards for rotating shafts and couplings must be used at all times when operating equipment and is the responsibility of the customer.

WARNING

BEFORE INSTALLATION OR ATTEMPTING ANY REPAIRS TO THE DRIVE, OPEN THE DISCONNECTS TO BOTH MOTORS, SHUT-OFF AIR SUPPLY AND LOCK THEM OUT TO AVOID THE POSSIBILITY OF PERSONAL INJURY. ALSO BLEED OFF ANY AIR PRESSURE TRAPPED IN THE SYSTEM.

3-1 RECEIVING THE *TSDr III* DRIVE

Check the drive for shortage or damage immediately after arrival. Prompt reporting to the carrier's agent, with notations made on the freight bill, will expedite satisfactory adjustment by the carrier. When unloading or handling the drive always keep it upright. All drives are filled with oil and ready to run at shipment. However, before placing the unit in service or storage check the oil level to make sure none has spilled out in transit. Add oil if necessary. Refer to **Section 4 Lubrication**. If the drive is not to be installed and operated soon after arrival, store it in a clean and dry place that has a slow and moderate change in ambient temperature. Actuate pistons and rotate shafts once a month to re-lubricate working surfaces.

NOTE:

Before shipment, the Air Breather (#88) is removed and a pipe plug put in its place. This is done to prevent oil spillage during shipment. In most cases this will be a red plastic plug. This plug must be removed and the Breather (#88) installed to prevent damage to the drive. The breather is taped to the drive for shipment.

3-2 MOUNTING THE *TSDr III* DRIVE

1. The drive should be mounted on a firm level base or foundation. Use socket head cap screws or SAE grade 5 bolts to bolt the drive securely in place.

Before tightening down the bolts, check alignment with driven machinery, then recheck after tightening.

2. If the Main Motor Shaft is to be directly coupled, use only a flexible coupling (with a horsepower service factor of 3 to 1) to take care of maximum torque requirements. Make sure the shafts to be coupled are concentric within the coupling manufacturer's specifications. Check for horizontal, vertical or angular misalignment. Use shims as necessary to correct any misalignment.

If the motor drives a belt, use sheaves with bushings. **Do not use sheaves with a straight bore, keyway and set screw.** Mount the pulley as close to the motor bearing as possible to minimize overhung load and align to run true.

CAUTION

Do not drive couplings or bushings on to the drive shaft. This may damage the bearings.

3. After the machinery has been in operation for a few hours, make sure that all mounting bolts are tight and recheck the alignment of all components.
4. After machinery has been in operation for 40 hours, check the mounting bolts and tighten if necessary.

3-3 WIRING SPECIFICATIONS

(See *Motor Plate*)

3-4 PNEUMATICS

For the best actuation time, use at least 3/8" dia. tubing or hose for the air supply and mount the control valve as close to the drive as possible. Use of bottom ports and mounting the control valve lower than the unit will also eliminate any accumulation of condensation in the TSDr III unit See *Figure 6.2* for Pneumatic Schematic.

3-5 START-UP

1. Lock out machine and air supply. Verify that the power is **OFF** to avoid personal injury.
2. Recheck all air connections for tightness and check to see if they are correct as shown in *Figure 6.2* Pneumatic Schematic.
3. Set clutch and brake air regulators to specified release pressure or higher. **See Section 2 Specifications.**
4. Unlock main disconnect.
5. Check operation of main motor and feed motor for proper rotation. Adjust all limit switches as needed.

FORCE CONTROL INDUSTRIES, INC.



MEX (55) 53 63 23 31 MTY (81) 83 54 10 18
QRO (442) 1 95 72 60 ventas@industrialmagza.com

Section 4 LUBRICATION

4-1 CHECKING THE OIL LEVEL

When the drive is installed and weekly thereafter, or until experience dictates otherwise, check the oil level. Always check the oil level with the drive at room temperature and while it is not running.

The **Two Speed Drive III (TSDr III)** has an Oil Sight Gauge (#87) located at the end of the Piston Retainer (#17) (See Figure 4.1). The oil level is to be at the center of this sight gauge.

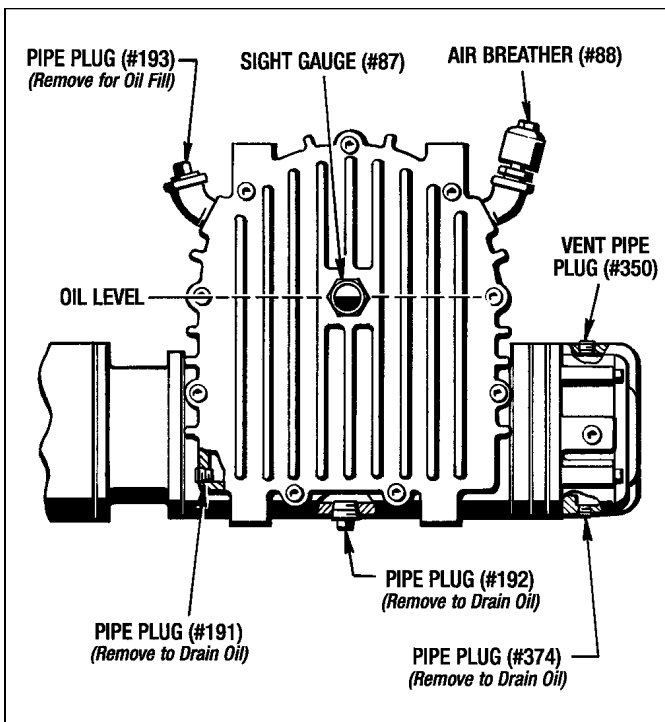

Figure 4.1 - Lubrication

4-2 OPERATING TEMPERATURES

A. Ambient Temperature

The standard oil used in the **Two Speed Drive III** was designed to operate between 40° F and 125°F. If the ambient temperature will fall outside of this range please contact Force Control Industries, Inc. for specific recommendations on proper lubricant and oil seals.

B. Oil Sump Temperature

The maximum recommended oil sump temperature is 200° F.

4-3 CHANGING THE OIL

IMPORTANT

Always open the disconnects to the drive motors before changing the oil.

Every three months completely drain the oil from the drive by removing Drain Plugs (#191), (#192) and (#374). If the Sight Gauge (#87) is dirty, it should also be removed and cleaned.

The oil should be changed more frequently when used in harsh environments or high cyclic applications.

Reinstall the Drain Plugs (#191), (#192) and (#374). Also reinstall the Sight Gauge (#87) back into the Piston Retainer (#17). Remove the Pipe Plug (#193) from the 45° Elbow (#199) on the right hand side and the Vent Pipe Plug (#350) from the Brake End Housing (#309). (See Figure 4.1)

Fill the unit with oil until the oil starts to come out the hole where the Vent Pipe Plug (#350) was. Reinstall the Vent Pipe Plug (#350) at this time and continue filling until the oil is in the center of the Sight Gauge (#87).

IMPORTANT

It is very important that this Vent Pipe Plug (#350) be removed when initially filling the drive unit with oil. This eliminates any air pockets in the brake section of the drive unit.

CAUTION

Do not overfill the drive unit. Excess oil will cause the drive to over heat.

Finally reinstall the Pipe Plug (#193).

4-4 TYPE OF OIL

Use only Mobil Automatic Transmission Fluid ATF-210 (Type "F") or Mobil Multi-Purpose Automatic Transmission Fluid for most drives.

Other fluids may be specified for special applications.

Always use the type of oil specified on the Name Plate. If the Name Plate is missing or there is any doubt about the proper fluid to use, contact Force Control Industries, Inc.

Section 5

OPERATIONAL CHECKS

5-1 CLUTCH/BRAKE OPERATION

CAUTION

Make operational checks with the drive shut down. Do not remove fittings or plugs while drive is running.

Provisions for manual operational checks are to be made if the unit has been removed for repair. Set up temporary manually controlled air connections to the drive for the required 60 to 80 PSI air supply.

A. Clutch Operation

Remove one of the Elbows (#199) from the top of the Piston Retainer (#17). Use this port as an inspection port. Manually apply air pressure to the clutch port and with a flashlight observe the clutch piston to see if it moves quickly and smoothly. If the piston action is irregular, or if it tends to stick or bind, internal damage may be indicated. Also, listen for air leaks and look for air bubbles in the oil that would indicate damage to the piston seals.

Exhaust the clutch air pressure and observe to see if the piston moves back to engage the clutch stack.

B. Brake Operation

To check the brake operation, apply 80 PSI to the brake port and manually turn the worm shaft. If the worm shaft can be turned by hand then the brake piston has been actuated. If after applying air pressure to the brake port the worm shaft cannot be turned by hand then the piston seals would be damaged.

Exhaust the brake air pressure and try to turn the worm shaft by hand. If you can turn the worm shaft by hand with no air pressure applied then the piston would be sticking or springs would be broken.

5-2 DRIVE MOTORS

Check wiring connections against the wiring diagram on the motor nameplate. "Bump" the motor and check the direction of rotation. Check to see if all wiring connections are tight.

5-3 PNEUMATIC CONTROL

The typical pneumatic control for the *TSDr III* will not supply air to the drive when electrical power is off. In this mode the clutch and brake stacks are clamped so the main motor and feed motor cannot run. With a 70 PSI minimum air supply to the valve, the clutch is released by energizing the control valve solenoid for the clutch. With the clutch valve solenoid energized, the clutch piston will move away from the clutch stack. De-energizing the clutch valve solenoid will allow the piston to move back to engage the clutch stack.

The brake is released in the same manner as the clutch. The brake valve solenoid is energized, at which time air will be applied to the brake port. The air will move the piston away from the brake stack. Again the control valve should be applied with a 70 PSI minimum air pressure. Air pressures should be checked directly at the clutch and brake ports with diagnostic pressure gauges.

Section 6 TROUBLESHOOTING

6-1 TROUBLESHOOTING CHART

PROBLEM	POSSIBLE CAUSE	REMEDY
1. Both Clutch and/or Brake fails to engage properly.	Electrical control circuit. Air supply pressure regulator or piping. Worn friction surfaces. Piston sticking or broken return spring.	Check control circuit. Check for improper operation or leaks. Check parts for wear and replace if necessary. (See Section 6-2) Disassemble to extent necessary and inspect for damaged parts.
2. Picks up load too quickly.	Air pressure too high. Low oil level.	Reduce air pressure. Check oil level and add oil if necessary.
3. Clutch fails to disengage properly.	Electrical control circuit. Control valve not functioning properly. Low air pressure.	Check control circuit. Check valve operation and replace if necessary. Increase air pressure to 60 PSI minimum.
4. Noise and vibration.	Mounted on poor foundation. Misaligned couplings. Damaged bearing.	Improve installation. Tighten foot bolts. Recheck alignment and realign. Disassemble to extent necessary and inspect for damaged parts. Replace or return unit to factory for repair.
5. Noise: High pitched whine	Clutch engaged with main motor running.	Check control circuit.
6. Brake fails to disengage	Electrical control circuit. Control valve not functioning properly. Low air pressure.	Check control circuit. Check valve operation and replace if necessary. Increase air pressure to 60 PSI minimum.
7. Drive overheats.	Clutch or brake fails to engage or disengage properly causing excessive slippage. Inertia or resistance changed. Improper oil level.	Refer to Troubles 1, 3 and 6. Check with Force Control. Check oil level. Add or drain oil as necessary.

6-1 TROUBLESHOOTING CHART (Concluded)

PROBLEM	POSSIBLE CAUSE	REMEDY
8. Oil leakage.	Oil seal lips damaged. Wear sleeve damaged Gaskets. Poor ventilation Oil seal retainers.	Disassemble and replace. Disassemble and replace. Tighten all external bolts. Remove breather and clean. Tighten if loose.
9. Oil leakage out breather.	Damaged seal around piston. Oil level too high.	Disassemble and repair. Drain excess oil.
10. Worm shaft end play excessive (.020" max.)	Bearings bad.	Disassemble and replace.
11. Clutch or brake does not repeat.	Air pressure changed. *Oil temperature changed. Resistance in machine changed.	Check air pressure. Check temperature. Lubricate machine bearings.
12. Excessive water in exhaust.	Wet air supply.	Check air supply line. Install pneumatic dryer in air supply.
13. Brake or clutch fails to disengage properly.	Low air pressure.	Increase one regulator at a time in steps until satisfactory air pressure is attained.
14. Slow response of clutch and/or brake.	Compressed air starvation. Exhaust muffler clogged. Air supply. Oil in exhaust.	Insufficient air supply. Add accumulator tank before control valve. (150 cu. in. / min.) Remove muffler and clean. Valves too far from drive. Air lines too small. Use 3/8" or 1/2" lines with 1/4" adapters. Check drive for piston leakage. Check air line for source. (Lubricated air not recommended.)
15. Brake engages improperly.	Control signal.	Check limit switch.

* For installations requiring precise starting and stopping, operating temperatures are important. Operating temperatures between 116° F and 165° F are recommended. If the oil is allowed to drop to ambient temperatures overnight, the clutch input shaft should be run for approximately 1/2 hour before operating the machinery.

6-2 MEASURING STACK HEIGHT

To determine whether or not the Clutch Stack or the Brake Stack needs replaced because of wear, each stack needs to be measured.

Place the Stack into an arbor press and clamp firmly. Measure the **Stack Height** as shown in Figure 6.1. The **Minimum Worn Stack Height** for each stack is given in the Table below.

If the Stack measures under the **Minimum Worn Stack Height**, the stack needs replaced.

MINIMUM WORN STACK HEIGHT

Clutch/Brake	Min. (Nearest Fraction)
Clutch	1.656" (1-21/32")
Brake	.404" (13/32")

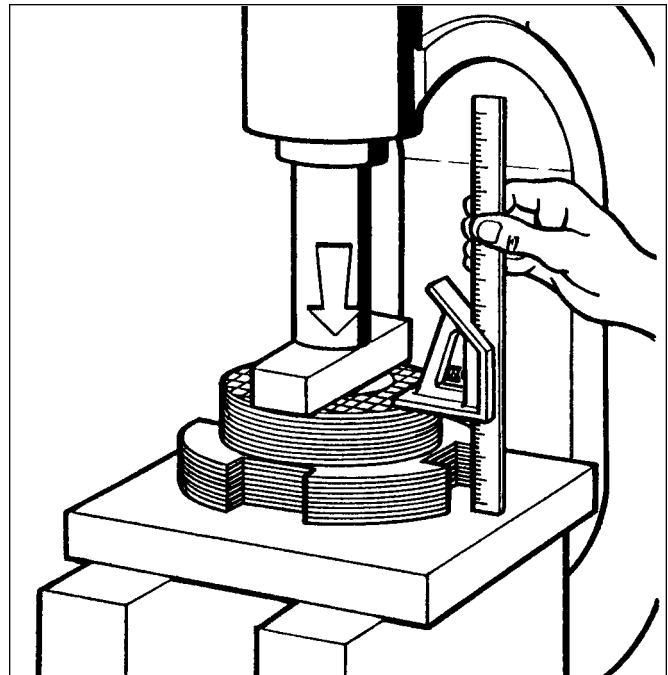

Figure 6.1 - Measuring Stack Height

6-3 PNEUMATIC SCHEMATIC

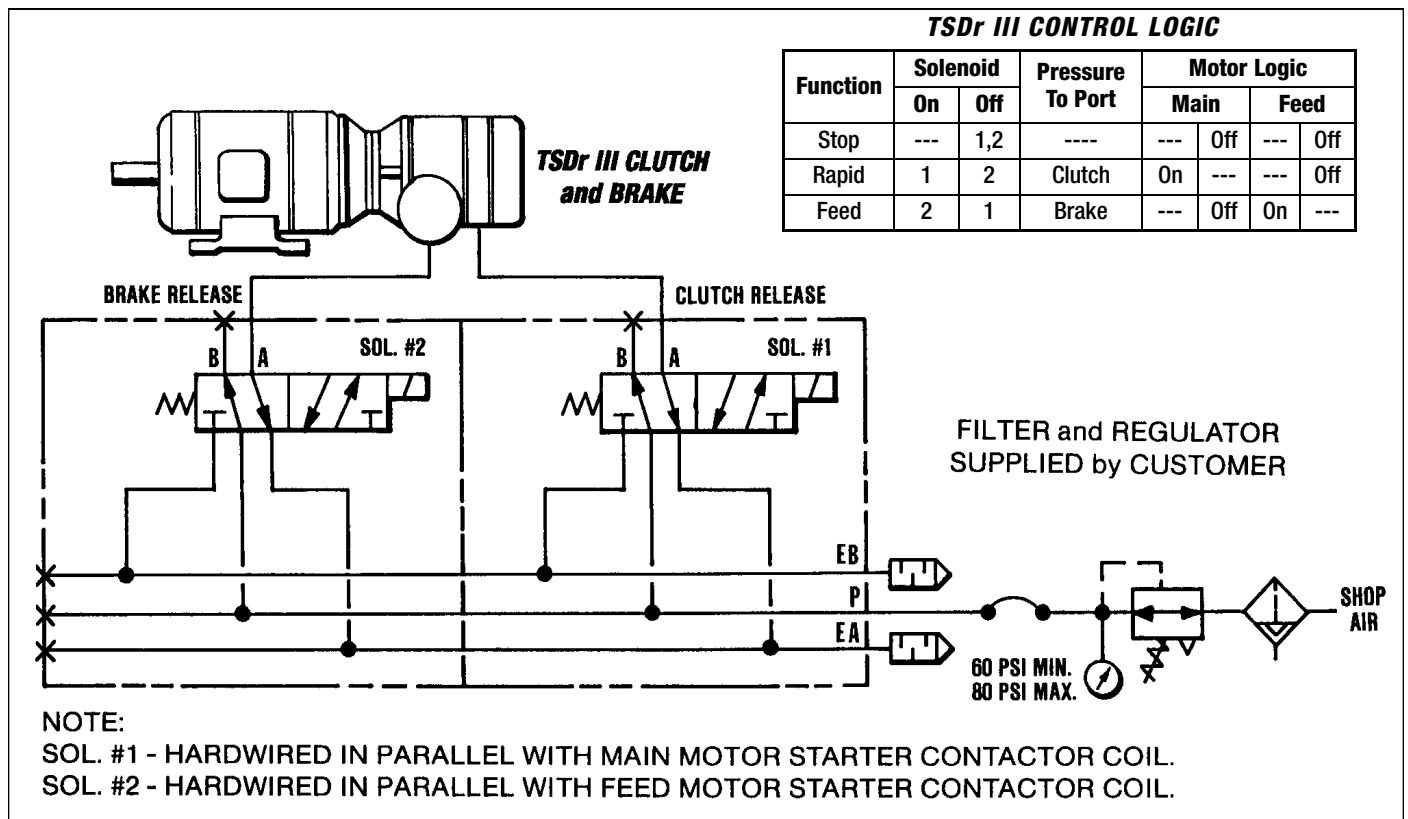

Figure 6.2 - Pneumatic Schematic

Section 7

REPAIR and REPLACEMENT

7-1 GENERAL INFORMATION

Because of the close tolerances that have to be maintained in the *Two Speed Drive III*, it is recommended that any repairs other than what is covered in this manual be done in our factory. Please contact Force Control Industries, Inc. Service and Sales Department for authorization and shipping instructions. Also see Section 8-3 for additional information on Force Control's Factory Rebuild Service.

An overhead crane and soft sling is recommended to be used in removing any heavy parts.

WARNING

Shut-Off and Lock-Out all air and electrical power before attempting to make any repairs to the drive unit.

7-2 REPLACING CLUTCH STACK and CLUTCH PISTON SEALS

(See Figure 8.1)

A. Disassembly Procedure

1. Drain the oil from the complete unit as specified in **Section 4-3 Changing The Oil**. Save or discard as conditions warrant.
2. Attach (2) 3/8"-16 eyebolts to the top of the Piston Retainer (#17) and support it with an overhead crane and soft sling.
3. Remove the (7) Screws (#144) and (7) Lock Washers (#174) and pull the Piston Retainer (#17) away from the Main Housing Assembly (#15).

4. Remove and discard Gasket (#45).
5. The **Clutch Stack** which is comprised of (9) Drive Plates (#13) and (9) Friction Discs (#12) can now be removed from the hub spline and input shaft lugs.
6. Measure the **Clutch Stack Height** as described in **Section 6-2** on Page 10.

If replacement of the Clutch Stack is the only repair to be made then jump ahead to **B. Reassembly Procedure** on the next page.

7. Place the Piston Housing (#16) and Retainer (#17) Assembly on a work bench with the Piston Retainer (#17) facing up.
8. Evenly back-out and remove the (2) Ferry Head Cap Screws (#180) and (2) Lock Washers (#174).

CAUTION - This Piston Retainer is under spring pressure so remove these (2) Screws (#180) in an even manner to relieve the spring pressure.

9. Separate the two housings and discard the Gasket (#45)
10. Remove the Springs (#83) from the spring pockets in the Piston (#18).

NOTE: Make a freehand sketch showing the location of the springs. This will help you at reassembly. (See Figure 7.3)

11. Remove the Screw (#270), Washer (#271) and the Anti-Rotational Bracket (#272) from the bottom of the Piston Housing (#16).

12. Pull the Piston Assembly straight up and out of the Piston Housing (#16) being careful not to damage the Piston Liner (#80) in the piston and (#81) located in the piston housing.

13. Remove the Liner (#81) and O-Ring (#76) from the Piston Housing (#16). Also remove the Liner (#80) and (2) O-Rings (#75) from the Piston (#18).

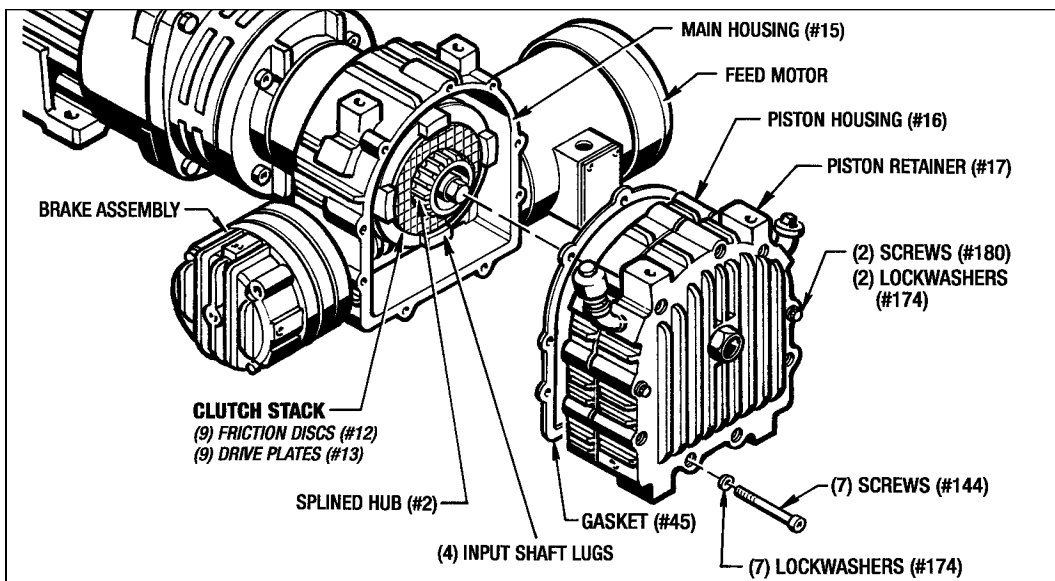

Figure 7.1 - Replacing Clutch Stack

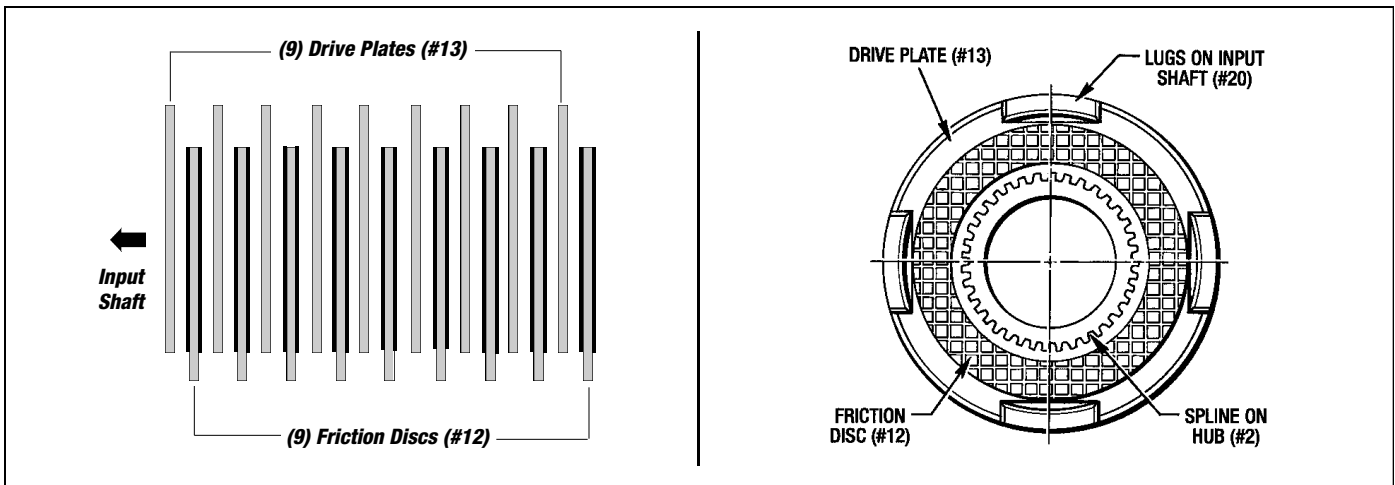

Figure 7.2 - Clutch Stack

B. Reassembly Procedure

- Lubricate the O-Ring (#76) and Liner (#81) with the same oil that is used in the drive and install them into the Piston Housing (#16). Also lubricate the (2) O-Rings (#75) and Liner (#80) and install them on the Piston (#18).
- Slide the Piston Assembly with the Pin (#273) located at the bottom into the Piston Housing (#16). **Be careful not to damage the Piston Liners.**
- Reinstall the Anti-Rotational Bracket (#272) with the Washer (#271) and Screw (#270).
- Replace the correct number of Springs (#83) back into the piston spring pockets. Use your freehand sketch that you made for correct placement or see Figure 7.3. White grease can be used to keep the springs in place.
- Place a Gasket (#45) onto the mounting face of the Piston Housing (#16). **Do not use any gasket sealant on this gasket.**
- Place the Piston Retainer (#17) into place and attach with (2) Lock Washers (#174) and (2) Screws (#180). Tighten these (2) Screws down in an even manner to compress the springs correctly. **Torque to 25 Ft. Lbs.**
- Starting with a Drive Plate (#13) then a Friction Disc (#12) install (9) Drive Plates and (9) Friction Discs back on the hub spline and input shaft lugs. (See Figure 7.2 above.)

NOTE: Make sure the spline teeth of the Friction Discs (#12) are all aligned with each other so they will slide onto the hub spline and the notches in the Drive Plates (#13) are aligned for the lugs on the input shaft.
- Place a new Gasket (#45) onto the mounting face of the Main Housing (#15). Use the (2) Pins (#14) for alignment. **Do not use any gasket sealant on this gasket.**
- Guide the Piston Housing (#16) back into place on the Main Housing (#15). Use the (2) Pins (#14) for alignment.
- Attach with (7) Screws (#144) and (7) Lock Washers (#174). **Torque to 25 Ft. Lbs.**
- Reinstall any drain plugs refill the unit with fresh oil to the center of the sight gauge. **See Section 4 Lubrication.**

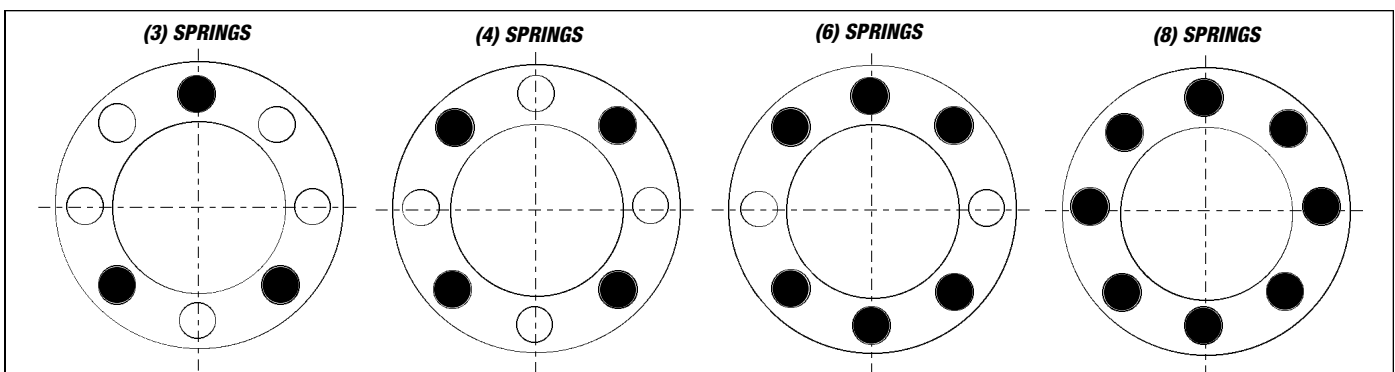

Figure 7.3 - Correct Spring Placement

7-3 REPLACING BRAKE STACK and BRAKE PISTON SEALS

(See Figure 8.3)

A. Disassembly Procedure

1. Drain the oil from the complete unit as specified in **Section 4-3 Changing The Oil**. Save or discard the oil as conditions warrant.
 2. Remove the (2) Screws (#352) and (2) Lock Washers (#327) from the End Housing (#309).
 3. Pull the Brake Assembly and Gasket (#902) off the Main Housing. Discard the Gasket (#902). (See Figure 7.4)
 4. Set the Brake Assembly on the work bench with the End Housing (#309) facing down. (See Figure 7.5)
 5. Remove the (2) Screws (#355) and (2) Lock Washers (#328) and take the Adapter (#900) and Gasket (#322) off the Brake Assembly. Discard the Gasket (#322).
- CAUTION - This Assembly is under spring pressure so evenly back out these (2) Screws (#355) until the spring pressure is relieved.**
6. Take the (6) Springs (#336) out of the spring pockets.
 7. Pull the Piston (#303) up and out of the End Housing (#309).

If the Piston Liners and O-Rings need replacing remove them at this time. If not skip to Step #9.

8. Take the Liner (#343) and (2) O-Rings (#340) off the Piston (#303). Then remove the Liner (#342) and (2) O-Rings (#339) from the End Housing (#309).
9. The Brake Stack, which consists of (4) Drive Plates (#312) and (3) Friction Discs (#313), can now be removed from the End Housing (#309). Lift up the stack off the (4) Pins (#357).
10. Measure the Brake Stack as described in **Section 6-2** on Page 10.

B. Reassembly Procedure

(See Figures 7.4 and 7.5)

1. Starting with a Drive Plate (#312), install it on the (4) Dowel Pins (#357). Then place a Friction Disc (#313) on the drive plate.

Continue this until all (4) Drive Plates (#312) and (3) Friction Discs (#313) are re-assembled. You will end up with a Drive Plate (#312) on top.

NOTE: Use (2) screwdrivers to align the spline teeth up with each other. **It is very important that all of the spline teeth are aligned with each other or they will not fit on the hub spline.**

If the Piston Liners and O-Rings were removed then reassemble them now. If not then go ahead to **Step-3** on the next page.

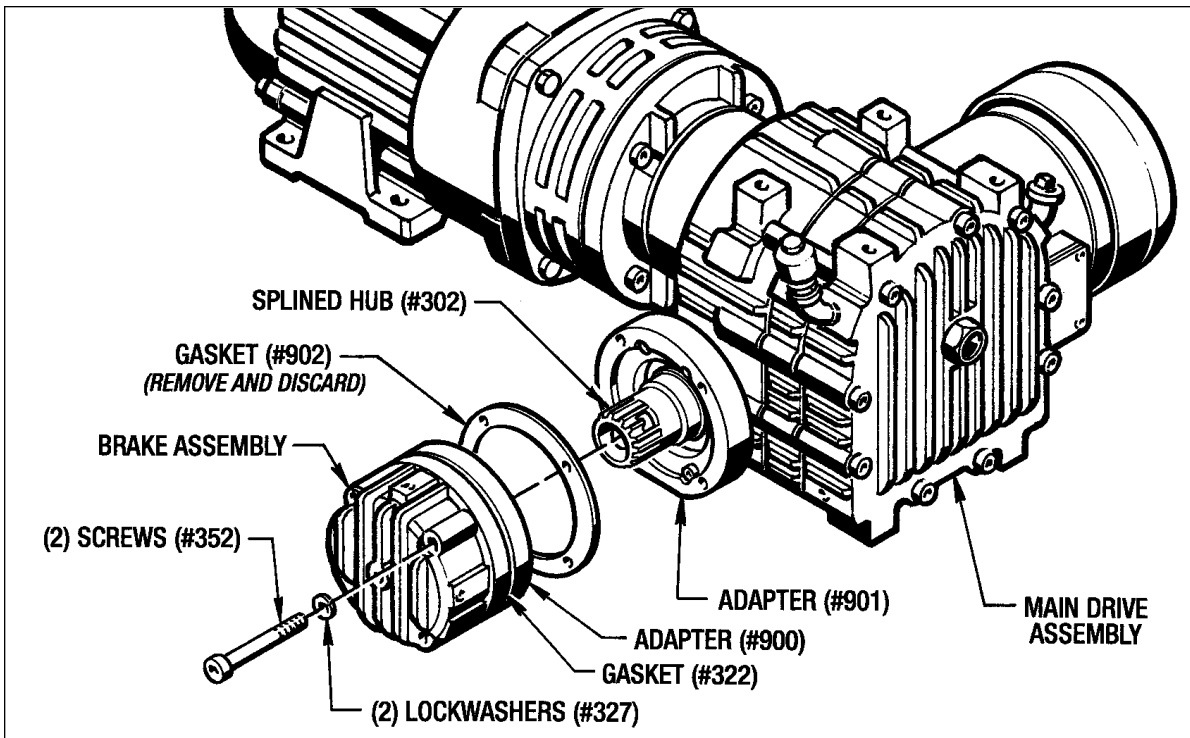

Figure 7.4 - Removing Brake Assembly

FORCE CONTROL INDUSTRIES, INC.



MEX (55) 53 63 23 31 MTY (81) 83 54 10 18
QRO (442) 1 95 72 60 ventas@industrialmagza.com

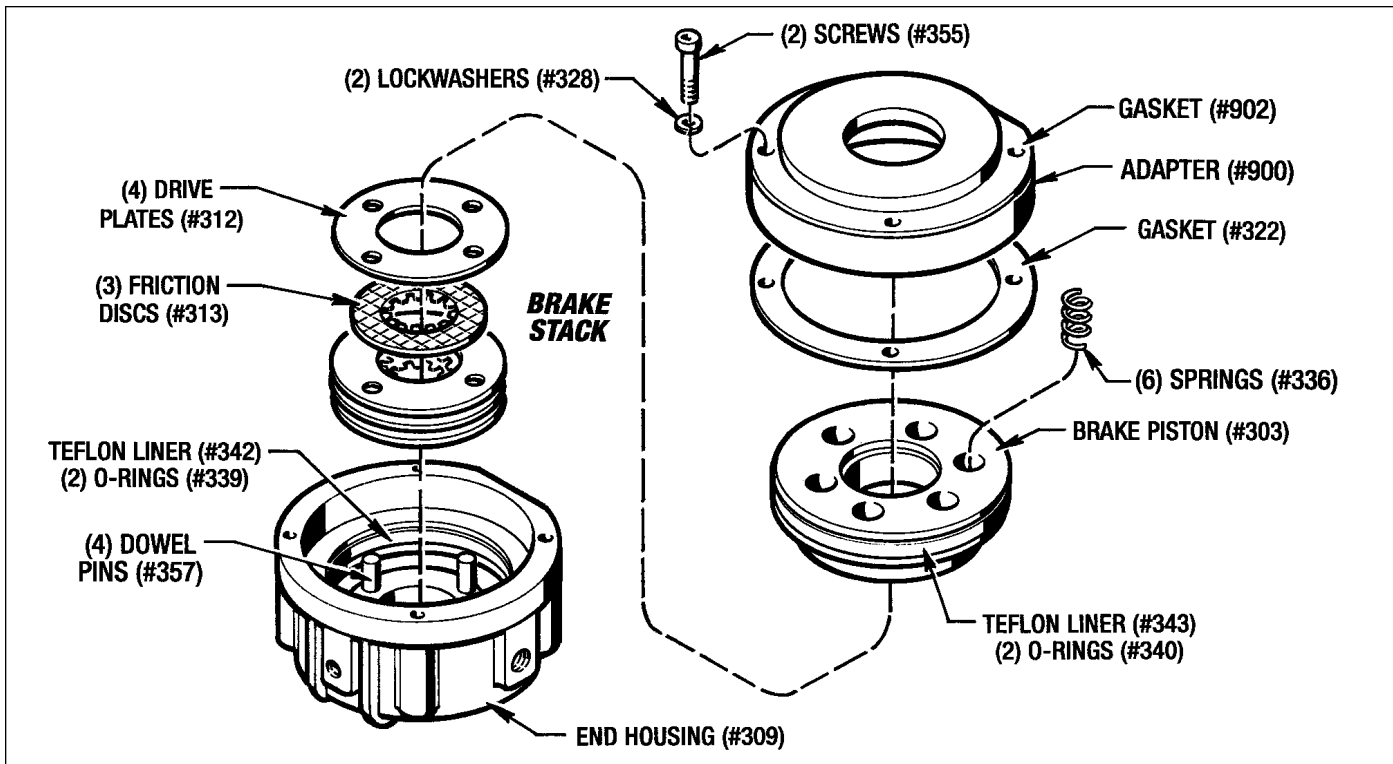

Figure 7.5 - Brake Assembly

2. Lubricate the (2) O-Rings (#339) and Liner (#342) with the same oil that is in the unit. Install them into the End Housing (#309).

Also lubricate the (2) O-Rings (#340) and Liner (#343) and install them on the Piston (#303).

3. Carefully insert the Piston (#303) into the End Housing (#309). Do not damage the Piston Liners. Push the Piston all the way down against the Brake Stack.
4. Re-insert the (6) Springs (#336) back into the spring pockets.
5. Place a new Gasket (#322) on the End Housing (#309). **Do not use any gasket sealant on this gasket.**
6. Lay the Adapter Plate (#900) in position and attach with (2) Screws (#355) and (2) Lock Washers (#328).
NOTE: Tighten these (2) Screws in an even manner to compress the (6) Springs (#336) correctly.
7. Position a new Gasket (#902) onto the Adapter Plate (#900) Use the (2) screw heads for positioning. **Do not use any gasket sealant on this gasket.**
8. Slide the whole Brake Assembly and Gasket (#902) over the Hub (#302) and attach with (2) Screws (#352) and (2) Lock Washers (#327). **Torque to 25 Ft. Lbs.**

9. Reinstall any drain plugs that were removed and fill the unit with fresh oil as specified in **Section 4 - Lubrication.**

7-4 REPLACING WORM SHAFT OIL SEAL (#64) (With Quill Worm Shaft)

(See Figure 8.2)

1. Drain the oil from the complete Unit as specified in **Section 4-3 Changing The Oil.**
2. Attach an overhead crane to the Inching Motor and take the (4) Screws (#148) and (4) Lock Washers (#172) out. Pull the Inching Motor away from the C-Face Adapter (#5).
3. Remove the C-Face Adapter (#5) from the Main Housing.
4. Inspect the O-Ring (#77) and replace if necessary.
5. Press the Oil Seal (#64) out of the C-Face Adapter (#5).
6. Clean out the bore and lightly coat with Permatex #3D Sealant. Press the new Oil Seal (#64) into the C-Face Adapter (#5) bore.
7. Inspect the Wear Sleeve (#68) on the Worm Shaft (#37) and, if necessary, replace it with the following procedure described in **Section 7-5.**

7-5 REPLACING WEAR SLEEVE (#68)

(With Quill Worm Shaft)

(See Figures 8.2 and 8.3)

1. Remove the (2) Screws (#352) and (2) Lock Washers (#327) and pull the Brake Assembly off.
2. Take the Gasket (#902) off and discard it.
3. Remove the (4) Screws (#150) and take the Adapter (#901) and Gasket (#132) off. Throw the gasket away.
4. The Worm Shaft (#37) along with Bearing (#57) and Hub (#302) can be manually pushed out of the brake side of the Main Housing Assembly.
5. Place the Worm Shaft (#37) into a suitable V-Block Support and with a chisel the same width as the Wear Sleeve (#68) make about 5 or 6 notches in the Wear Sleeve. The Wear Sleeve (#68) can now be removed from the Worm Shaft. (See Figure 7.6)

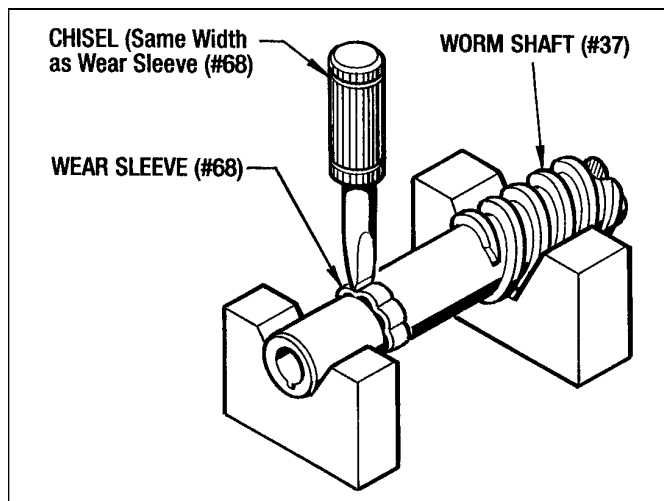

Figure 7.6 - Removing Wear Sleeve (#68)

A Wear Sleeve Installation Tool must be used to install the Wear Sleeve (#68) back on the Worm Shaft (#37).

To order the **Installation Tool** from Force Control, use **Part Number 601-72-003**

If you wish to make your own, dimensions are given in Figure 7.7.

6. Place the Worm Shaft in an arbor press as shown in Figure 7.8. **Step 1** - Press the Wear Sleeve (#68) on to the Worm Shaft with **Surface "A"** of the Installation Tool. **Step 2** - Turn the Installation Tool over and with **Surface "B"** finish pressing the Wear Sleeve (#68) on the Worm Shaft until it bottoms out on the shaft shoulder.
7. Reinstall the Worm Shaft back into the Main Housing from the brake side. Make sure the Bearing Spacer (#23) is still in the bearing bore of the main housing.

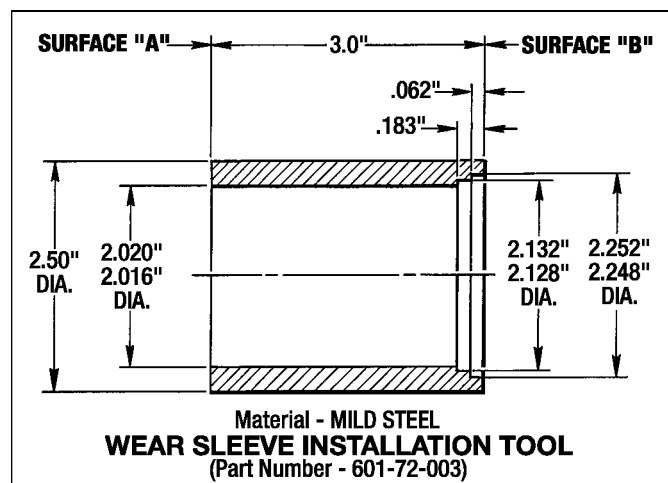
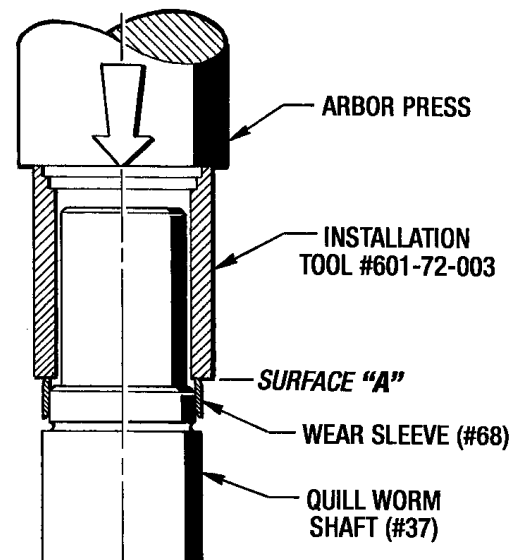

Figure 7.7 - Wear Sleeve Installation Tool #601-72-003

Step 1



Step 2

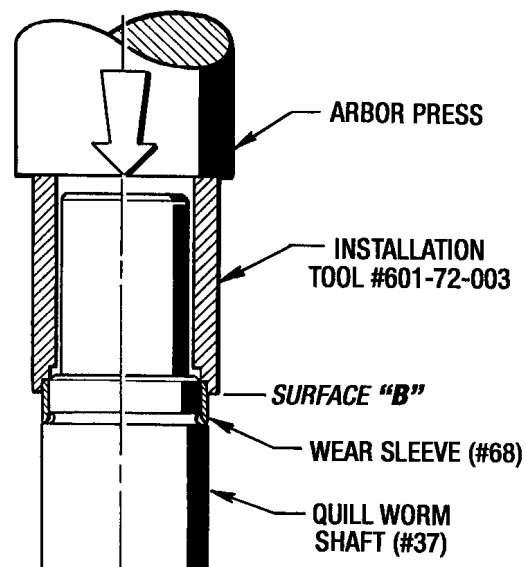

Figure 7.8 - Installing Wear Sleeve (#68) on Quill Worm Shaft

FORCE CONTROL INDUSTRIES, INC.



MEX (55) 53 63 23 31 MTY (81) 83 54 10 18
 QRO (442) 1 95 72 60 ventas@industrialmagza.com

8. Lubricate the O-Ring (#77) and install it on the C-Face Adapter (#5).
9. Re-attach the C-Face Adapter (#5) to the Main Housing with (4) Lockwashers (#174) and (4) Screws (#145). **Be careful not to damage the Oil Seal Lip when inserting the worm shaft into it.**

Torque Screws (#145) to 25 Ft. Lbs.

- 10 Place a new Gasket (#132) on the Adapter (#901) and attach them to the Main Housing (#15) with (4) Screws (#150). **Apply Blue Loctite and torque to 25 Ft. Lbs.**
11. Place a new Gasket on the Brake Assembly.
12. Slide the Brake Assembly and Gasket (#902) over the Hub (#302) spline and attach with (2) Screws (#352) and (2) Lock Washers (#327). **Torque to 25 Ft. Lbs.**
13. Re-attach the Feed Motor with the (4) Screws (#148) and (4) Lock Washers (#172). **Torque to 60 Ft. Lbs.**
14. Refill the Drive Unit with fresh oil as directed in **Section 4 - Lubrication.**

**7-6 REPLACING WORM SHAFT OIL SEAL (#63)
(With Male Worm Shaft)**

(See Figure 8.2)

1. Drain the oil from the complete unit as specified in **Section 4-3 - Changing The Oil.**
2. Remove the Drive Belt and Sheave from the end of the Worm Shaft (#37). Also remove the Key (#40).
3. Remove the Bearing Retainer (#22) by taking out the (4) Screws (#145) and (4) Lockwashers (#174).
4. Take the Shims (#132) off and save for reassembly.
5. Press the Oil Seal (#63) out of the Bearing Retainer (#22).
6. Clean the oil seal bore out and lightly coat it with Permatex #30 Sealant. Press the new Oil Seal (#63) into the Bearing Retainer (#22) with an arbor press.

The **TSDr III** has a Wear Sleeve (#69) on the Worm Shaft. Check this Wear Sleeve (#69) for any nicks, scratches or other damage that would cause leakage. If it doesn't need replacing, reinstall the Bearing Retainer, Shim, Key, Drive Sheave and Drive Belt as described in the next **Steps 7, 8, 9 and 10.**

If it does need replaced then 1st. follow the procedure given in the next **Section 7-7 - Replacing Wear Sleeve (#69).**

7. Clean off the old Shims (#132) with solvent. Re-spray the Shims with **"Copper Coat Gasket Compound"**.
8. Reinstall the Shim (#132) and the Bearing Retainer

(#22) back on the Main Housing Assembly with (4) Lockwashers (#174) and (4) Screws (#145). **Be careful not to damage the oil seal lip when inserting the Worm Shaft.**

9. Re-install the Key (#40), Drive Sheave and Drive Belt back on the worm shaft.
10. Replace all drain plugs and refill the unit with fresh oil as specified in **Section 4 - Lubrication.**

**7-7 REPLACING WEAR SLEEVE (#69)
(With Male Worm Shaft)**

(See Figures 8.2 and 8.3)

1. Remove the (2) Screws (#352) and (2) Lock Washers (#327) and pull the Brake Assembly off.
2. Take the Gasket (#902) off and discard it.
3. Remove the (4) Screws (#150) and take the Adapter (#901) and Shims (#132) off. Save the shims for re-assembly.
4. From the drive side, tap the end of the Worm Shaft (#37) with a wooden mallet until the Bearing Spacer (#23) and the Bearing Cup (#55) located on the brake side is knocked out of the bearing bore. Continue pulling the Worm Shaft out of the Main Housing.

NOTE: The (2) Bearing Cones (#55) will remain on the Worm Shaft and the other Bearing Cup (#55), located on the drive side will remain in the bearing bore. It is also not necessary to remove the Hub (#302) and the Collet (#306) from the Worm Shaft to replace the Wear Sleeve.

6. Place the Worm Shaft (#37) into a suitable V-block support or vice and with a chisel the same width as the Wear Sleeve (#69) make about 5 or 6 notches in the Wear Sleeve. The Wear Sleeve (#69) can now be removed from the Worm Shaft. (See Figure 7.6).

A Wear Sleeve Installation Tool must be used to install the Wear Sleeve (#69) back on the Worm Shaft (#37).

To order the **Installation Tool** from Force Control, use **Part Number 601-72-002.**

If you wish to make your own, dimensions are given in **Figure 7.9.**

7. Place the Worm Shaft in an arbor press as shown in **Figure 7.10. Step 1** - Press the Wear Sleeve (#69) on to the Worm Shaft with **Surface "A"** of the Installation Tool. **Step 2** - Turn the Installation Tool over and with **Surface "B"** finish pressing the Wear Sleeve on the Worm Shaft until it bottoms out on the shaft shoulder.
8. Slide the Worm Shaft (#37) back into the Main Housing bore.

FORCE CONTROL INDUSTRIES, INC.

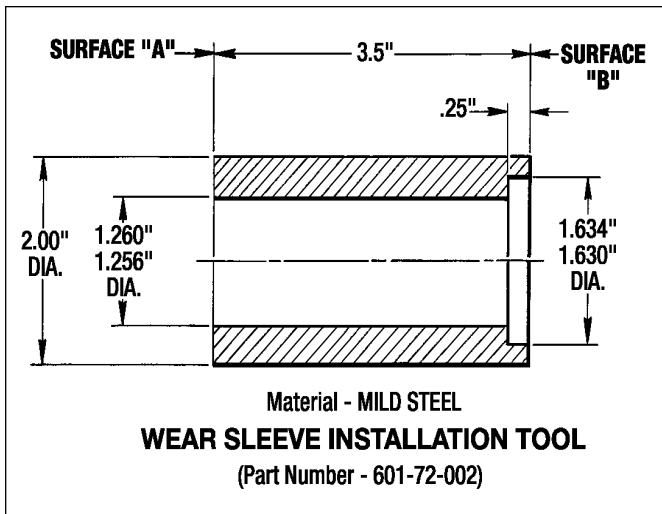

Figure 7.9 - Wear Sleeve Installation Tool #601-72-002

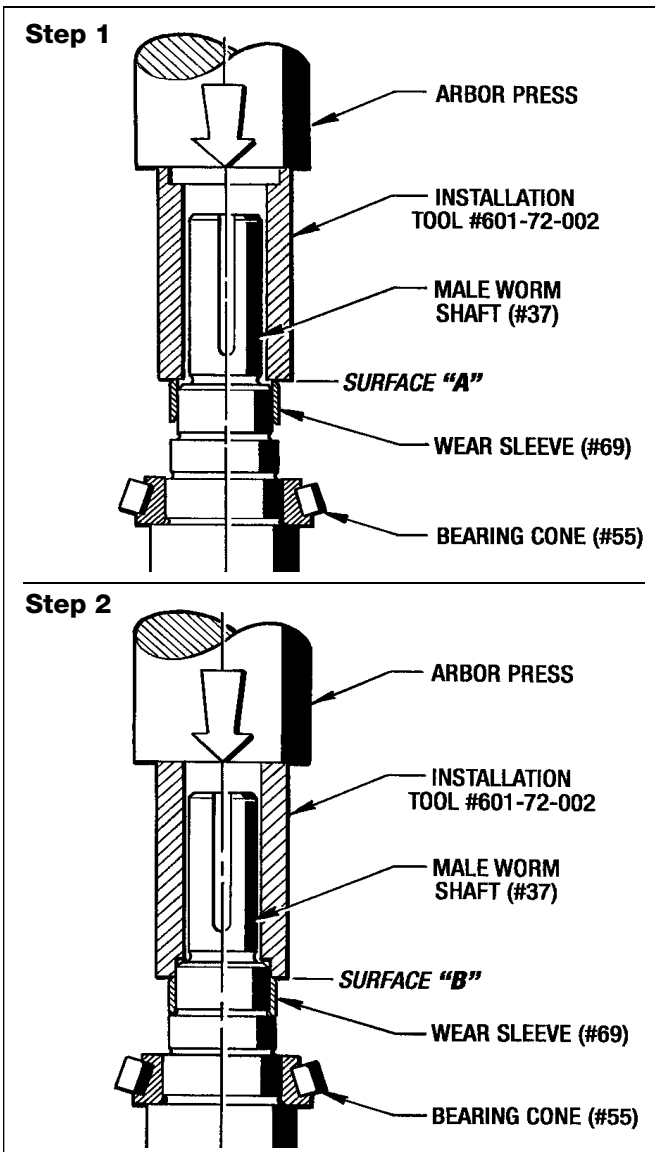

Figure 7.10 - Installing Wear Sleeve on Male Worm Shaft

9. Place a Bearing Cup (#55) and the Spacer (#23) into the bearing bore located on the brake side. On the drive side, replace the remaining Bearing Cup (#55)
10. Clean the Shims (#132) off with solvent. Re-spray the Shims with "**Copper Coat Gasket Compound**".
11. Install the Shims (#132) and the Bearing Retainer (#22) with the (4) Lockwashers (#174) and (4) Screws (#145) back on the drive side. **Do not torque screws at this time**
12. On the brake side clean the Shims (#132) off with solvent. Re-spray the Shims with "**Copper Coat Gasket Compound**".
13. Install the Shims (#132) and attach the Adapter (#901) with (4) Screws (#150) to the brake side of the Main Housing. **Do not torque at this time.**
14. The **End Play** of the Worm Shaft must be checked before going any further. This can be done by setting a Dial Indicator on the end of the Worm Shaft and manually pushing the shaft in and out while rotating it. The **End Play should be between .002" and .004"**. Add or subtract Shims (#132) as necessary. (See Figure 7.11.)

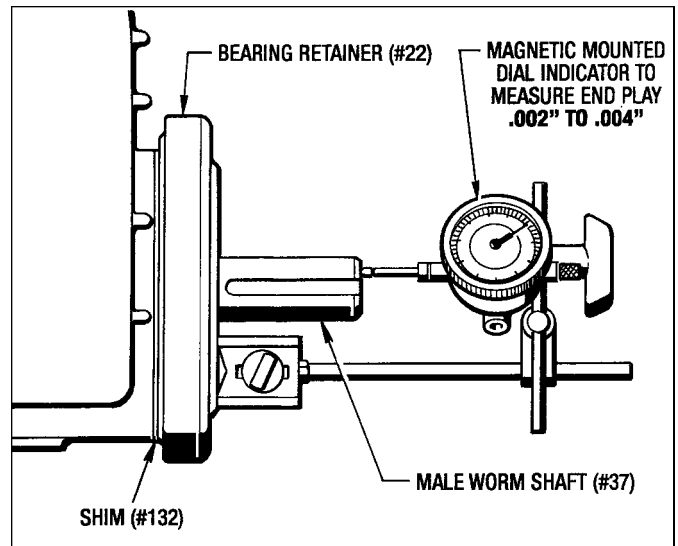

Figure 7.11 - Checking Worm Shaft End Play

15. After the End Play is correctly set, **torque Screws (#145) and (#150) to 25 Ft. Lbs.**
16. Place a new Gasket on the Brake Assembly.
17. Slide the Brake Assembly and Gasket (#902) over the Hub (#302) spline and attach with (2) Screws (#352) and (2) Lock Washers (#327). **Torque to 25 Ft. Lbs.**
16. Reinstall the Key (#40), Drive Sheave, Drive Belt and any other parts removed for repair.
17. Refill the unit with fresh oil to the center of the sight gauge as described in **Section 4 - Lubrication.**

7-8 REPLACING WEAR SLEEVE (#67) AND OIL SEAL (#62)

(See Figure 8.1)

A. Disassembly Procedure

Complete the same Disassembly Procedure as described in **Steps 1 through Steps 9 (excluding Step 8) in Section 7-2 Replacing Clutch Stack.**

Note: When removing the Clutch Stack keep the Drive Plates (#13) and Friction Discs (#12) in the same order as they were removed.

10. Attach an overhead hoist and soft sling to the top of the Main Housing (#15).
11. Remove the (4) Screws (#142) and (4) Lock Washers (#169) from the C-Face Adapter (#1).
12. Remove the (3) Screws (#149) and (3) Lock Washers (#176). Pull the Bearing Retainer (#21) out of the Input Shaft (#20).
13. Remove the Hex Hd. Screw (#143) and Seal Washer (#43) from the Hub (#2).

The Collet (#6) has to be loosened up from the taper bore in the Hub (#2) to get the Main Housing Assembly off the main motor shaft.

Two Special Tools must be used to loosen this collet from the hub. They are described in *Figure 7.12.*

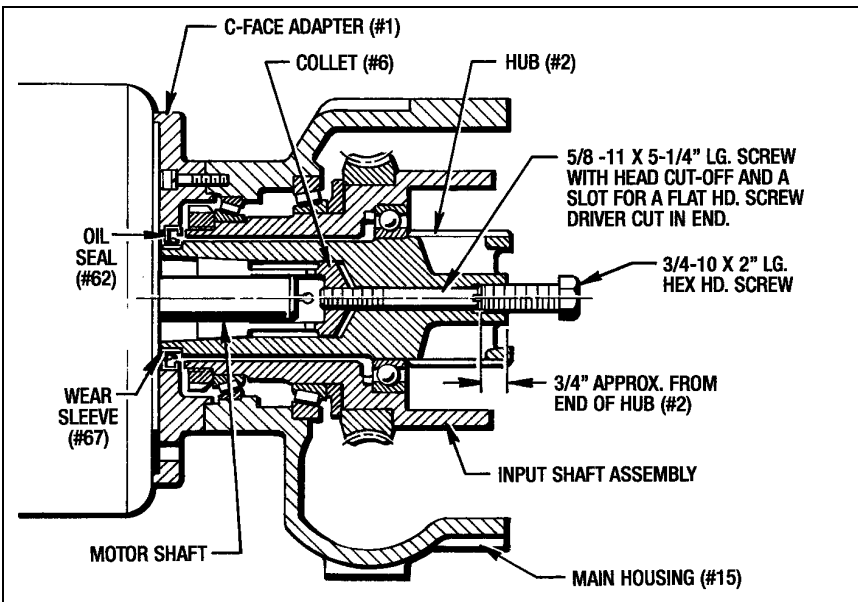

Figure 7.12 - Loosening Collet (#6) from Hub (#2)

14. Insert the 5/8" - 11 x 5-1/4" Lg. Tool into the Hub (#2) and screw it into the Collet (#6) until it is approx. 3/4" from the end of the Hub (#2).
15. Screw in the 3/4" - 10 x 2" Lg. Screw. Tighten until the Hub (#2) is loosened from the Collet (#6).

16. Pull the Main Housing Assembly straight back off the Main Drive Motor.

B. Replacing Wear Sleeve (#67)

(See Figure 8.1)

1. Pull the Hub (#2) out of the Input Shaft (#20). The Ball Bearing (#50) will stay on the hub shoulder and the Wave Spring (#82) should stay in the bearing bore.
2. With the same procedure as shown in Figure 7.6 remove the Wear Sleeve (#67) from the Hub (#2). *Figure 7.6 is on page 15.*

With a hammer and a chisel the same width as the Wear Sleeve (#67) make several notches in the sleeve to release it from the hub surface. Pull the Wear Sleeve (#67) off the Hub (#2).

3. A new Wear Sleeve (#67) can be pressed on with an arbor press and a suitable round flat plate. Apply a light coat of (Loctite #277) to the ID of the Wear Sleeve. Press until the sleeve is flush with the end of the hub.

C. Replacing Oil Seal (#62)

(See Figure 8.1)

1. Take the C-Face Adapter (#1) off the Main Housing (#15) by removing the (4) Screws (#141) and (4) Lock Washers (#170).

2. Remove the O-Ring (#47) from the C-Face Adapter.
3. Press the old Oil Seal (#62) out with an arbor press and a suitable round flat plate.
4. Clean the oil seal bore in the C-Face Adapter (#1) with a suitable solvent.

Recoat the bore with gasket sealant and press a new Oil Seal (#62) back into the bore with an arbor press and a suitable flat round plate.

D. Reassembly Procedure

(See Figure 8.1)

1. Insert the Hub (#2) and Bearing (#50) back into the Input Shaft (#20). Make sure the Wave Spring (#82) is in place.
2. Attach the Bearing Retainer (#21) with (3) Screws (#144) and (3) Lock Washers (#176).
3. Turn the Drive Assembly upright with the collet end of the Hub (#2) in the up position.
4. Install the O-Ring (#47) onto the C-Face Adapter (#1). Use white grease to hold it in place.

5. Lubricate the lip of the Oil Seal (#62) and the Wear Sleeve (#67) with the same oil as used in the drive.
 6. Lower the C-Face Adapter (#1) onto the Main Housing (#15) being very careful not to damage the oil seal lip when it goes over the Wear Sleeve (#67). Attach with (8) Screws (#141) and (8) Lock Washers (#170). **Torque to 25 Ft. Lbs.**
 7. Place the Collet (#6) on the motor shaft until it bottoms out. **IMPORTANT-Do not use any lubricant on the motor shaft of collet.**
 8. Pick-up the Drive Assembly with an overhead hoist and tap the collet end of the Hub (#2) with a rubber mallet until the Bearing (#20) is up against the Bearing Retainer (#21).
 9. Slide the Assembly over the Collet (#6) and attach with (4) Screws (#142) and (4) Lock Washers (#169). Torque to 120 Ft. Lbs.
 10. Screw a 5/8" - 11 x 10" Lg threaded rod through the Hub (#2) and into the Collet (#6). Pull back firmly to seat the collet into the taper bore of the hub.
 11. Remove the threaded rod and install Screw (#143) and Brass Washer (#43) into the Hub (#2). **Use Blue #272 Loctite on the threads. Torque to 180 Ft. Lbs.**
- Use the same procedure given on page 12 **B. Reassembly Procedure** to reassemble the Clutch Stack, Piston Housing, Piston Assembly and Piston Retainer back on the Main Drive Assembly.
- Use all 9 Steps except Step 2 if the Piston Seals were not previously removed.

Section 8

ILLUSTRATED PARTS LIST

8-1 GENERAL INFORMATION

This section illustrates, lists and describes all parts for the **Two Speed Drive Type III**. Parts are identified on the exploded views with Part Reference Numbers. These Numbers correspond to the Part Reference Number given in the Parts Lists. The Part Name and Quantity Used is also given in the Parts List. This Part Reference Number, Part Name and Quantity should be used when ordering Replacement Parts.

8-2 DRIVE MOTORS

The Drive Motors used with these **Two Speed Drives Type III** are standard motors and may be repaired or replaced by any qualified Motor Re-build Facility or Supplier.

8-3 FACTORY REBUILD SERVICE

Reconditioning Service is offered by Force Control Industries, Inc. at the factory. A complete factory rebuild will be 50% the cost of a new unit if the housings are reusable. If Housings need to be replaced, there will be an additional cost.

Contact **Force Control Industries, Inc.** for authorization and shipping instruction before returning a drive unit for this service. Force Control cannot be responsible for units returned to the factory without prior notice and authorization.

Care must be given to the packing of returned drives. Always protect mounting feet by attaching to a skid.

Shipment-damaged drives always delays repairs. It is usually impossible to recover damage costs from the carrier. When possible, describe the problem experienced on your shipping papers.

Return to: **Force Control Industries, Inc.**

**3660 Dixie Highway
Fairfield, Ohio 45014**

Phone: (513) 868-0900

Fax: (513) 868-2105

E-Mail: info@forcecontrol.com

8-4 ORDERING REPLACEMENT PARTS

When ordering replacement parts, please specify all of the following information:

1. Drive Model Number (On the Name Plate.)
2. Drive Serial Number (On the Name Plate.)
3. Part Reference Number (From the parts list or exploded view drawing.)
4. Part Name (From the parts list.)
5. Quantity (From the parts list.)
6. Complete Shipping Information.

Failure to include information for items 1 through 6 will only delay your parts order. Unless another method is specified for item 6, parts weighing less than 150 Lbs. will be shipped United Parcel Service. Parts weighing more than 150 Lbs. will be shipped Motor Freight. Air freight and other transportation services are available but only if specified on your order.



8-5 NAME PLATE AND MODEL NUMBER

The Name Plate shown is located on the Brake End Housing.

TWO SPEED DRIVE Type III MODEL NUMBER

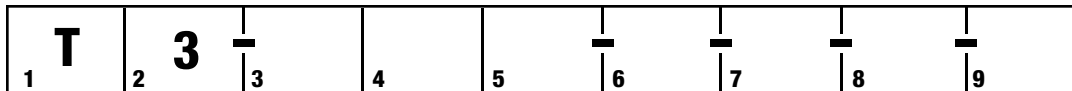

(1, 2) TWO SPEED DRIVE III

(3, 4, 5) INCHING SPEED (RPM)

With Foot Mounted Inching Motor (Belt Drive)

* 013	60:1 029	049	24:1 073	099	133	**182
* 014	030	050	074	100	134	**185
* 015	031	051	075	101	135	**190
* 016	48:1 032	30:1 053	076	102	136	**194
* 017	033	054	077	106	146	**198
* 018	034	055	20:1 080	15:1 107	**156	**204
019	036	058	081	108	**157	**209
020	037	059	082	109	**159	**211
021	038	061	087	117	**160	**219
60:1 022	40:1 040	062	088	119	12:1 With Speed Up Belt Drive **166	
023	041	063	090	122	**168	
024	044	24:1 064	092	124	**171	
025	045	066	15:1 093	12:1 125	**172	12:1 With Speed Up Belt Drive
026	30:1 046	067	095	127	**175	
027	047	068	097	128	**179	

* Indicates 1200 RPM Inching Motor.

** Indicates Inching Motor must be rated above Req'd. Torque Rating.

With C-Face Mounted Inching Motor
(1750 RPM Motor)

023 (80:1)	117 (15:1)
036 (48:1)	146 (12:1)
073 (24:1)	360 (5:1)
087 (20:1)	

(9) REVISION
(By Force Control)

(8) INCHING MOTOR MOUNTING

- 1** = C-Face, 4-1/2 AK, 7/8 U, 182U/184U Fr., 143T/145T Fr.
- 2** = C-Face, 8-1/2 AK, 1-1/8 U, 213U/215U Fr., 182T/184T Fr.
- 3** = C-Face, 8-1/2 AK, 1-3/8 U, 254U/256U Fr., 213T/215T Fr.
- 4** = Foot Mounted, 182U/184U Fr.
- 5** = Foot Mounted, 213U/215U Fr.
- 6** = Foot Mounted, 143T/145T Fr.
- 7** = Foot Mounted., 182T/184T Fr.
- 8** = Foot Mounted, 213T/215T Fr.

(7) ASSEMBLY CONFIGURATIONS
(See Next Page)

(6) MAIN MOTOR MOUNTING

- A** = 1-1/8" FU, 10-1/2" AK
- B** = 1-3/8" FU, 10-1/2" AK
- C** = 1-5/8" FU, 10-1/2" AK
- D** = 1-7/8" FU, 10-1/2" AK
- E** = 1-1/8" FU, 12-1/2" AK
- F** = 1-3/8" FU, 12-1/2" AK
- H** = 1-5/8" FU, 12-1/2" AK
- J** = 1-7/8" FU, 12-1/2" AK

(7) ASSEMBLY CONFIGURATIONS (All Views Looking at Motor Shaft.)

TSDr III C-Face Mounted Feed Motor

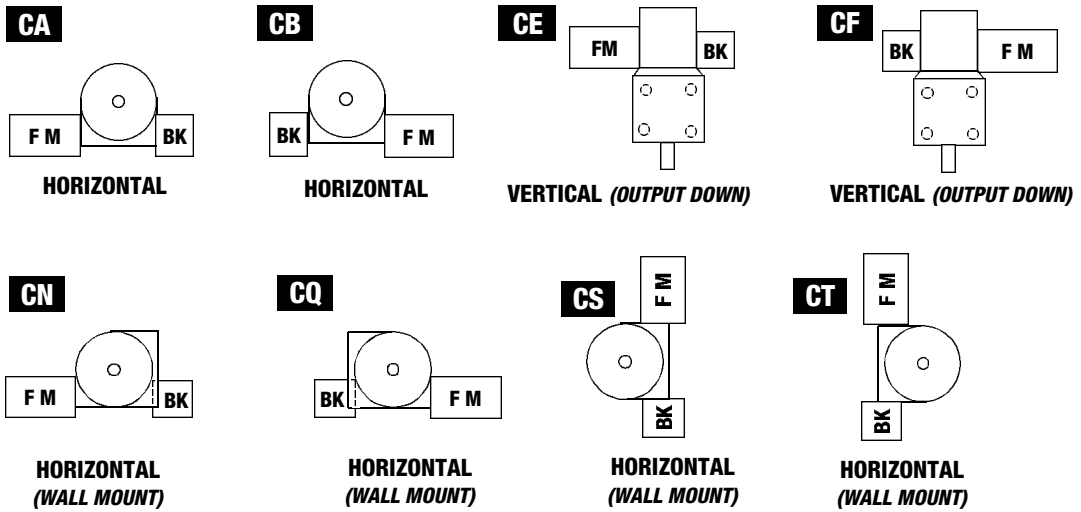

TSDr III Foot Mounted Feed Motor

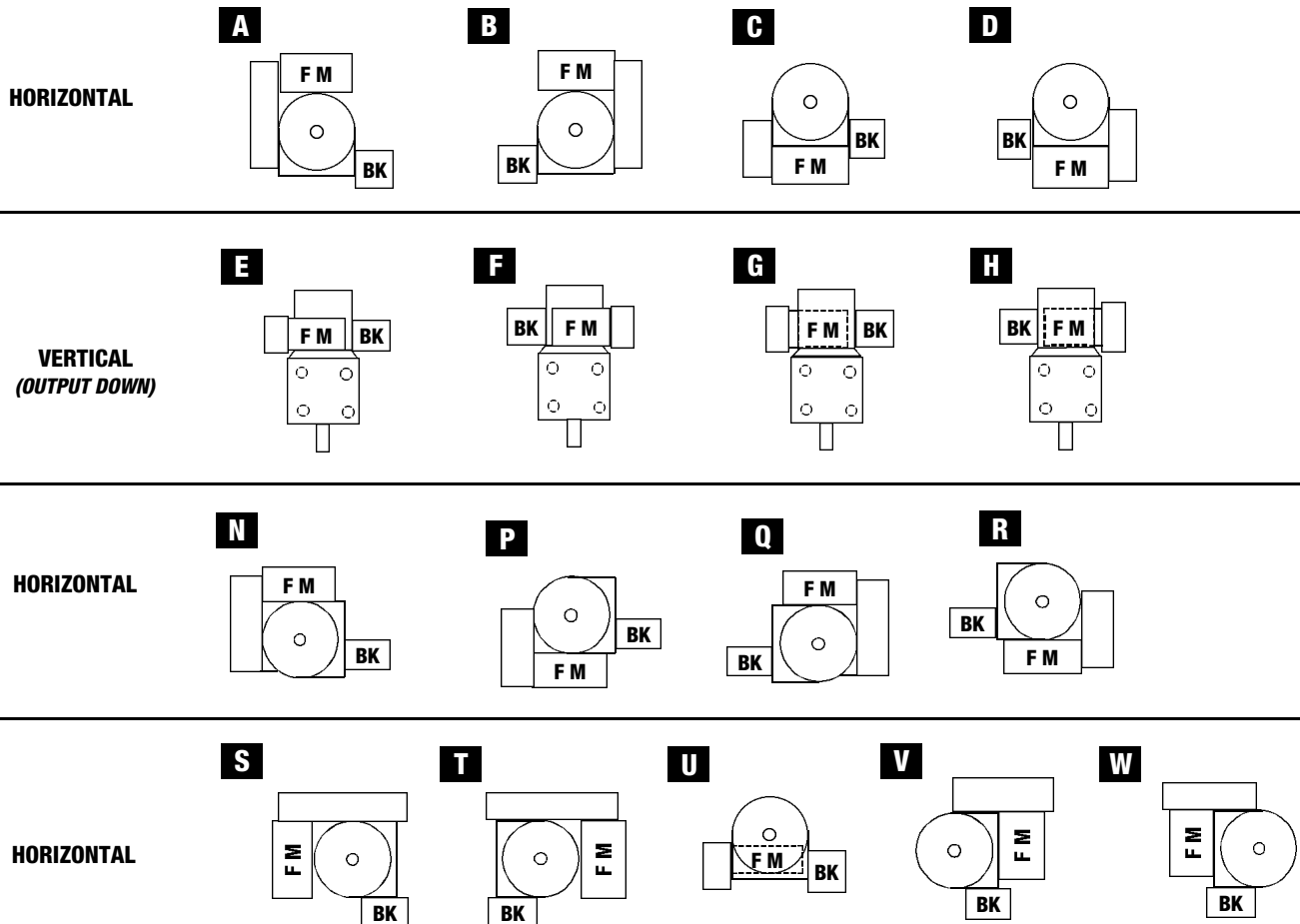

REPAIR PARTS LIST
MAIN HOUSING AND CLUTCH STACK
(Figure 8.1)

Ref. No.	Part Name	Qty.	Ref. No.	Part Name	Qty.
1	C-Face Adapter.....	1	*76	O-Ring	1
2	Hub	1	*80	Liner, OD Sealing	1
6	Collet.....	1	*81	Liner, ID Sealing	1
*12	Friction Disc	9	*82	Wave Spring	1
*13	Drive Plate	9	*83	Spring (See Chart Below.)	AR
14	Dowel Pin, 3/8" x 3/4"	2	**87	Sight Gauge	1
15	Main Housing	1	**88	Breather	1
16	Piston Housing	1	*137	Shim	AR
17	Piston Retainer	1	141	Soc. Hd. Cap Screw, 3/8-16 x 1-1/2" Lg. ..	8
18	Piston	1	142	Hex Hd. Cap Screw, 5/8-11 x 1-1/2" Lg.	4
**19	Thrust Plate, Clutch	1	143	Hex Hd. Cap Screw, 5/8-11 x 5" Lg.	1
20	Input Shaft	1	144	Soc. Hd. Cap Screw, 3/8-16 x 5" Lg.	7
21	Bearing Retainer.....	1	149	Low. Hd. Cap Screw, #10-24 x 1/2" Lg.	3
25	Spacer	1	169	Lock Washer, 5/8".....	4
**26	Locknut	1	170	Lock Washer, 3/8".....	8
38	Worm Gear	1	174	Lock Washer, Hi-Collar, 3/8".....	9
39	Key	1	176	Lock Washer, #10.....	3
43	Copper Washer Gasket, 5/8"	1	180	Ferry Hd. Cap Screw, 3/8-16 x 2-1/2" Lg.	2
*45	Gasket	2	190	Reducer Bushing, 3/8" x 1/4" NPT	1
*47	O-Ring	1	191	Pipe Plug, 3/8" NPT	2
*50	Ball Bearing	1	192	Pipe Plug, 1/2 NPT	1
*51	Ball Bearing	1	193	Pipe Plug, Sq. Hd., 3/4" NPT	1
*53	Bearing Cone	1	199	45° Street Elbow, 3/4" NPT	2
*54	Bearing Cup	1	260	Threaded Insert	2
*58	Bearing Cone	1	270	Soc. Hd. Cap Screw, 1/4"-20 x 5/8" Lg.....	2
*59	Bearing Cup	1	271	Lock Washer, 1/4".....	2
*62	Oil Seal	1	272	Bracket, Anti-Rotational	1
*67	Wear Sleeve	1	273	Dowel Pin, 3/16" x 1" Lg.	1
*75	O-Ring	2			

NOTES:

* - Indicates parts in Minor Overhaul Kit.

** - Indicates parts in Major Overhaul Kit. (This Major Overhaul Kit also includes all parts in the Minor Overhaul Kit.)

AR - As Required.

SPRING (#83) QTY. REQ'D.

REQ'D. TORQUE (Lb. Ft.)	SPRING (#83)	
	TYPE COLOR	QTY. REQ'D.
126	Medium Blue	3
168		4
252		6
323	Heavy/Red	3
335	Medium Blue	8
430	Heavy/Red	4
646		6

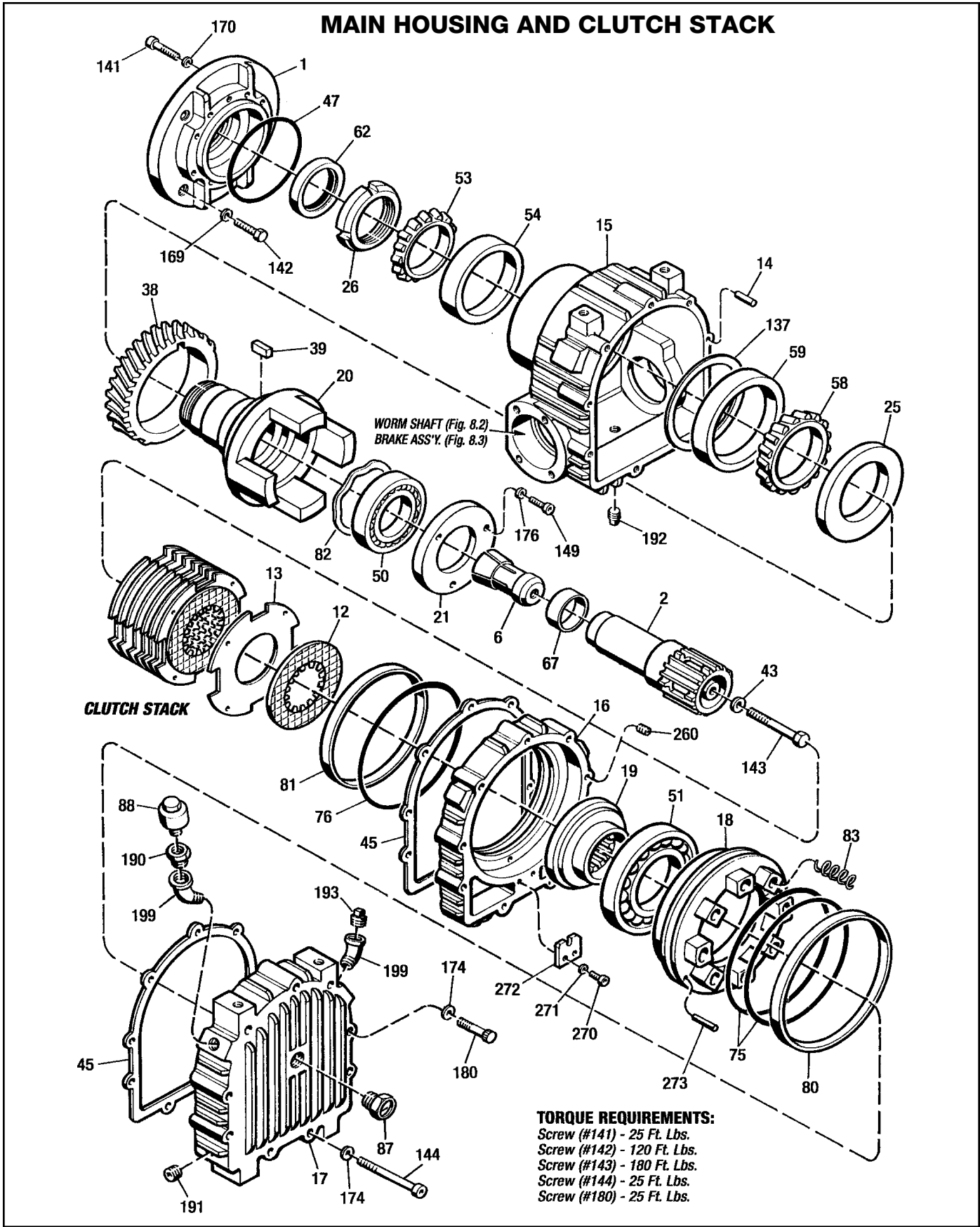

Figure 8.1 - Repair Parts-Main Housing & Clutch Stack

FORCE CONTROL INDUSTRIES, INC.



MEX (55) 53 63 23 31 MTY (81) 83 54 10 18
 QRO (442) 1 95 72 60 ventas@industrialmagza.com

REPAIR PARTS LIST
SECONDARY WORM SHAFT AND BRAKE ASSEMBLY
(Figures 8.2 and 8.3)

Ref. No.	Part Name	Qty.	Ref. No.	Part Name	Qty.
5	C-Face Adapter	1	*313	Friction Disc	3
22	Bearing Retainer	1	*322	Gasket	1
23	Spacer	1	327	Lock Washer, 3/8"	2
29	Spacer	1	328	Lock Washer, 5/16"	2
37	Worm Shaft	1	*336	Spring	6
40	Key	1	*339	O-Ring	2
*55	Tapered Roller Bearing	2	*340	O-Ring	2
*57	Ball Bearing	1	*342	Liner, ID Sealing	1
*63	Oil Seal	1	*343	Liner, OD Sealing	1
*64	Oil Seal	1	349	Pipe Plug, 1/8" NPT	2
*68	Wear Sleeve	1	350	Pipe Plug, 1/4" NPT	1
*69	Wear Sleeve	1	351	Hex Hd. Screw, 3/8-16 x 1" Lg.	1
*77	O-Ring	1	352	Soc. Hd. Cap Screw, 3/8-16 x 3-3/4" Lg. ..	2
*132	Gasket (C-Face Drive)	1	353	Heli-Coil (In Housing #309)	2
*132	Shim (Belt Drive)	AR	355	Soc. Hd. Cap Screw, 5/16-18 x 1-1/2" Lg.	2
145	Soc. Hd. Cap Screw, 3/8-16 x 5" Lg.	4	356	Heli-Coil Insert (In Adapter #901).....	2
148	Soc. Hd. Cap Screw, 1/2-13 x 1-1/2 Lg. ..	4	357	Dowel Pin	4
150	Low Hd. Cap Screw, 3/8-16 x 1" Lg.	4	373	Pipe Plug, 3/8" NPT	1
172	Lock Washer, 1/2"	4	374	Pipe Plug, Sq. Hd. Mag, 1/8" NPT	1
174	Lock Washer, 3/8"	4	375	Pipe Plug, 1/4" NPT	2
302	Hub	1	386	Wear Sleeve (In Housing #309).....	1
303	Piston.....	1	900	Adapter PLate	1
306	Collet	1	901	Adapter.....	1
309	End Housing	1	*902	Gasket	1
*312	Drive Plate	4			

NOTES: * - Indicates parts in Minor Overhaul Kit. AR-As Required.

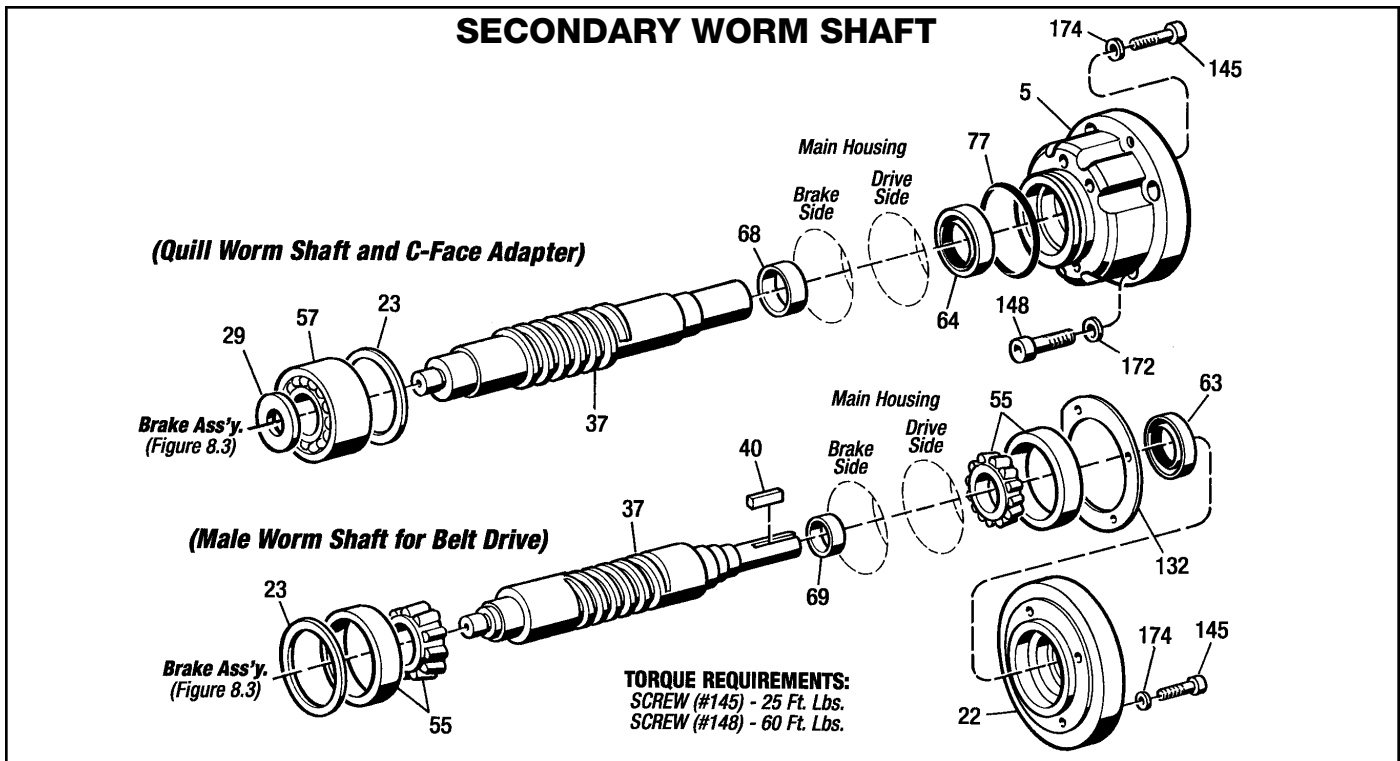

Figure 8.2 - Repair Parts-Secondary Worm Shaft

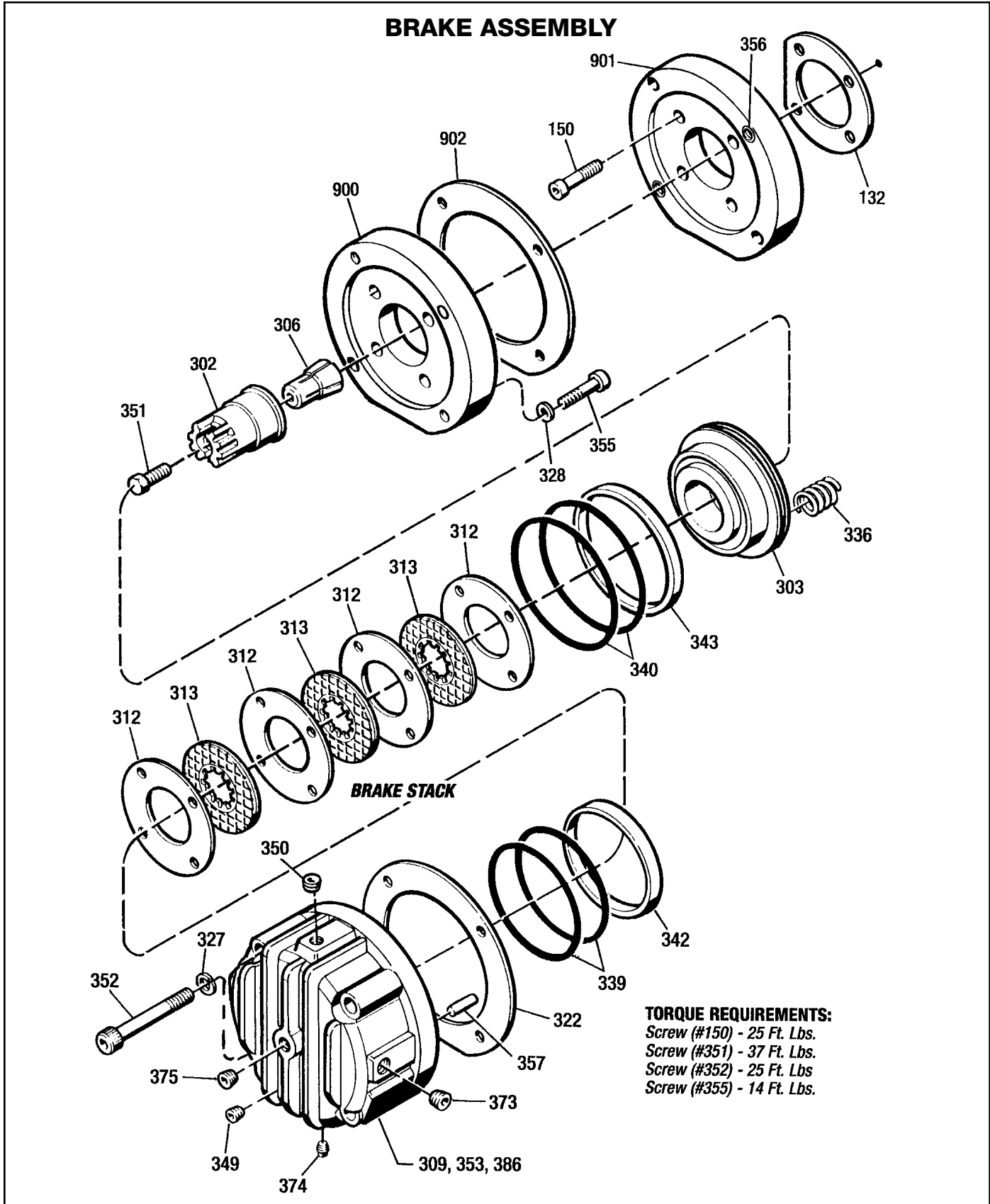

Figure 8.3 - Repair Parts-Brake Assembly

FORCE CONTROL INDUSTRIES, Inc.

*Providing today's industries
with Oil Shear Clutch and
Brake Drives that delivers:
Flexibility • Efficiency
Endurance • Performance
Dependability*

“Built to Last - Guaranteed to Perform”



FORCE CONTROL INDUSTRIES, INC.

MAIN OFFICE

P.O. Box 18366
Fairfield, Ohio 45018

3660 Dixie Highway
Fairfield, Ohio 45014

Tel: (513) 868-0900
Fax: (513) 868-2105

E-Mail: info@forcecontrol.com
Web Site: www.forcecontrol.com