

BULLETIN BC-104MA

P-1346-1

Installation Instructions

Type BC-Series "MA" Backstop

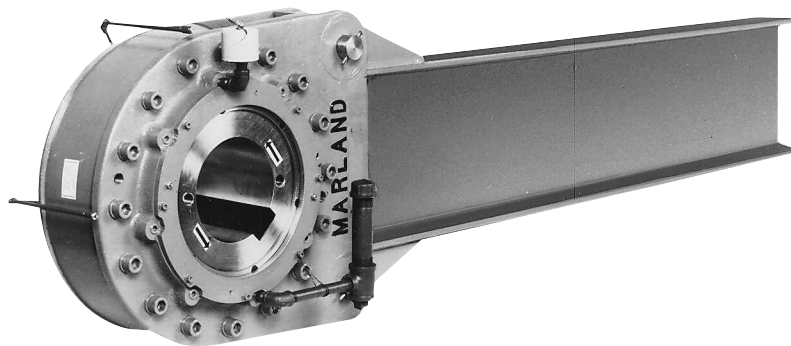

800-216-3515 • 630-455-1752

www.marlandclutch.com

▲ WARNING Failure to follow these instructions may result in product damage, equipment damage, and serious or fatal injury to personnel.

Installation, Lubrication, and Maintenance

General

Marland automatic backstops are precision built safety devices designed to protect inclined conveyors or vertical elevators from the dangers of gravity accelerated reversed runaway. To be assured of reliable protection and the longest possible service life, it is important that the following recommendations be observed for the installation, lubrication, and maintenance of Marland backstops.

As soon as the unit has been received, examine it carefully for damage in transit and report any breakage discovered to the transit company at once.

All tags and bulletins attached to the unit should be carefully read before placing the unit in operation and then filed for future reference.

All units are shipped without oil.

Care must be taken not to place the unit in operation until it has been filled with oil of proper specification to the static oil level.

The various component parts referred to in this bulletin may be readily identified on Illustration 3 and Parts List.

If the backstop is to be stored for an extended period of time (over 3 months) before installation, see step 2 for instructions.

Long Term Storage

Backstop units should be completely filled with oil. Store inside, if possible, in a clean dry area.

Once every two months the cam should be rotated by hand to lubricate the rotating elements.

Exposed, unpainted surfaces should be "Brush Painted" with a rust preventative.

Before placing the backstop in operation, completely drain and refill with the proper quantity of oil and install per the following procedure.

Installation

A. Check for proper free shaft rotation
The backstop is symmetrical which allows it to be mounted for the desired direction of free shaft rotation.

The arrow inscribed on each cam face indicates the direction of free shaft rotation. Before mounting the backstop on the shaft, be sure to check direction of free rotation.

B. Methods for Axial Shaft Retention
Since backstops are not a tight fit on shafts, some methods of retention should be used to prevent the backstop from "walking" on the shaft, as this may cause the end of the torque arm to contact the stirrup and cause premature bearing failure.

Illustration 2 shows some of the different possibilities for retaining the backstop. These are only suggestions and are not intended to be all-inclusive or restrictive in any way.

C. Mount Backstop on Shaft
Backstop bores are straight and finished to size for an "easy push" fit on a shaft that is straight and not tapered. Shafts should be smooth and free of burrs.

Coat the end of the shaft with oil, white lead, grease, or powdered graphite for easy mounting of the backstop.

Check again to make certain that the arrow on the backstop cam face is in the same direction as the desired free shaft rotation.

If shaft retention collars are to be used to retain the backstop's position on the shaft, install the inboard collar and tighten set screw into position.

Push the backstop on the shaft, taking care to push only on the cam face or inner labyrinth (Part #10), thus eliminating undue abuse on the bearings within the backstop. Evidence of damage during assembly caused by disregard of the above instructions is readily traceable and Marland Clutch will not be held responsible for failure of such affected part or parts.

The outboard shaft collar, if required, can now be installed and locked into position.

Do not use tapered keys. Keys must be straight.

To locate the backstop on the shaft, the key should be "drive tight" fit on sides only. To provide for adequate top of key clearance, the straight keyway in the bore of the backstop has been made 1/32" deeper than standard. Overall length of the key should not exceed the length of the cam and inner labyrinths.

For backstops installed at the end of the shaft, an enclosing end cover or cap can be provided to cover the end of the rotating shaft. A flat cover can be used when the shaft does not extend beyond the cam face.

If the shaft does extend beyond the cam face, such as when an outboard shaft collar is used, a shaft end cap can be furnished.

See Illustration 2 for end cover and end cap possibilities.

Attach "I" Beam Torque Arm to Backstop (After Rotation Check)

Attach "I" beam torque arm to the backstop with the furnished pins and cotter keys.

Do not fasten torque arm end rigidly to steel framework in angular or axial position.

Torque arm end should have a minimum of 1/4" top clearance in its stirrup to make certain that it does not rust in or pack tight with foreign matter. Approximately 1-1/2" clearance should be provided at each side of the torque arm for axial positioning.

The backstop must be centered on the shaft to prevent possible ball bearing damage from misalignment that might occur if the torque arm is held rigid.

Also, if end of torque arm is twisted crosswise, a pinching action may be imposed on the ball bearings and cause heating.

If the headshaft alignment position changes in time, the previous precautions will allow the backstop to remain centered on the shaft without danger or pinching or skewing caused by a rigidly fastened torque arm end.

Safe backstop mounting is possible at any desired angle of the torque arm. However, straight vertical mounting is not recommended. A minimum angle of approximately 5 degrees from vertical should be maintained (see diagram and caution on Illustration 4).

If mounted downward through floor slot, place a suitable boot or hood around torque arm at or above floor level to keep foreign matter from restricting possible torque arm movement at the floor opening.

Install Piping Kit

A. Install grease gun and grease pressure-relief fittings.

Remove two plastic plugs spaced at approximately 180 degrees from each other on the outer labyrinth plate. Place one grease gun fitting in each outer labyrinth plate, preferably at upper of the two openings. An angle fitting is furnished for the inboard labyrinth plate. See drawing BCMA OIL-1998 for piping assembly.

Place one grease pressure-relief fitting in each outer labyrinth plate. This is to be inserted in the remaining opening which is located approximately diametrically opposite from the grease gun fitting to insure a full circle grease seal.

B. Install Oil Level Indicator/Filler Drain

The tee pipe fitting with oil drain plug and riser nipple with cap should be located at the lowest position (nearest 6 o'clock) oil inlet hole of one coverplate on the easiest-to-reach side of backstop. A sufficient number of oil inlet holes are provided to permit arrangement of the oil level indicator/filler drain at or near the bottom of the backstop for any position of the torque arm. Use the furnished wrench to remove oil hole plugs.

The highest point of riser nipple should be horizontally level with the center of the shaft.

C. Install Oil Breather Filter and Fittings

Remove the pipe plug on the coverplate that is above the center of shaft and as near the 12 o'clock position as possible. Assemble and install oil breather filter fittings. The breather must be positioned vertically.

When the operating temperature increases and expands the air in the backstop, it can escape at the breather-filter and not force oil through lip seals.

Lubrication

Before placing unit in operation, backstop must be filled internally with DEXRON III Automatic Transmission Fluid (or alternative lubrication as shown in Table 1) which is readily obtainable from industrial oil suppliers or automotive supply stores.

Oils containing high lubricity or EP additives must not be used in backstop units. Never use grease for internal lubrication of backstops. Never use carbon tetrachloride, which is detrimental to neoprene seals. The use of improper lubricants could cause a malfunction resulting in equipment damage.

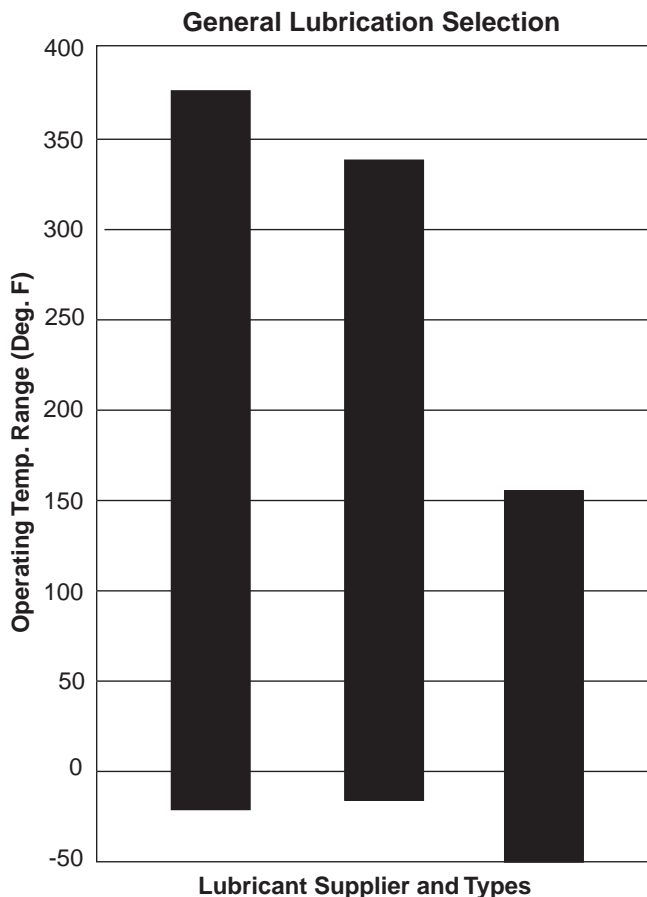

	Mobil Multi-Purpose ATF (Dexron-III)	Texaco Havoline ATF (Dexron-III)	Chevron ATF (Dexron-III)
	DTE-15M	Rando-HDZ 46	Hyd. Oil AW MV 56
	Aero HF	Aircraft Hyd. Oil 5606G	Aviation Hyd. Fluid A

Table 1

A. To Fill With Oil

1. Remove Cap from riser nipple on Oil Level Indicator.
2. Slowly add oil through riser nipple with a clean quantity of oil as specified on nameplate, certified drawing, and on Table 2.
3. Replace Cap on riser nipple.

B. Maintenance

Lubrication maintenance should not be performed while equipment is in operation.

In order to provide proper lubrication maintenance, the following procedures are recommended:

- Once in 3 months, add Texaco Starplex #1, #2, or equal, grease at grease fittings located on both ends of the backstop until fresh grease appears at relief fittings.
- Once in 3 to 6 months: (Also After First Week of Operation)
 1. Thoroughly clean around breather filter. Remove only the breather filter. Replace the breather filter element if dirty.
 2. Drain oil from lowest oil plug in TEE fitting.
 3. Replace drain plug.
 4. Flush unit by adding a clean quantity of oil as specified on the nameplate, certified drawing, or on Table 2. Allow 5 to 10 minutes operation for flushing action.
 5. Remove drain plug to drain flushing oil.
 6. Replace drain plug and fill with specified quantity of oil as shown on the nameplate, certified drawing, or on Table 2.
 7. Replace breather filter and cap on oil level-filler riser nipple.
 8. Retighten coverplate bolts after first week of operation.

If coverplate bolts and lube fittings are kept snug tight, then the frequency with which the backstop's lubrication should be inspected is an important consideration and can only be determined by individual experience. However, it is considered desirable to inspect the oil level of the backstop once a week for the first month of service. The results of these inspections will dictate the frequency of future samplings, but in any event should not exceed three to six month intervals. Under severe working conditions, it may be necessary to check the backstop at a more frequent interval.

Double Block Retention Key

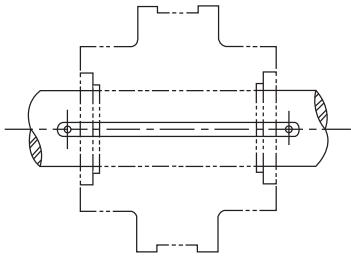

Keeper Plate and Shaft Shoulder

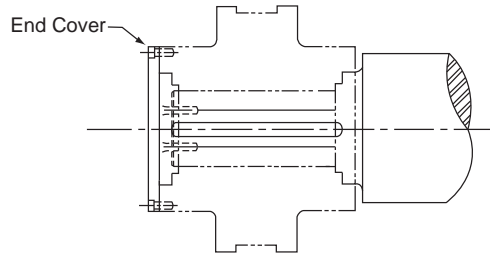

Two Shaft Collars

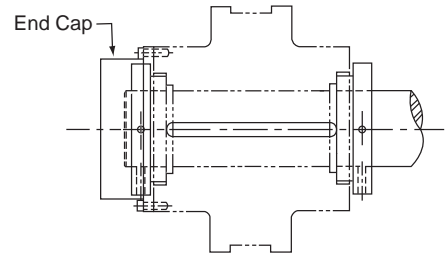
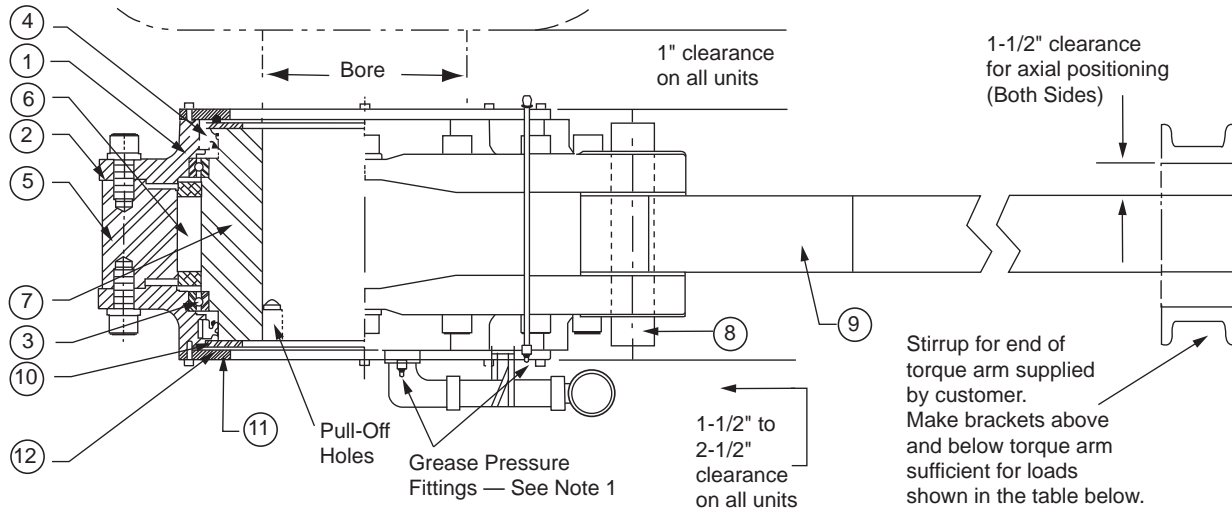

Illustration 2



Part #	Description	Part #	Description	Part #	Description
1	Coverplate	5	Outer Race	9	Torque Arm
2	Gasket	6	Roller Assembly	10	Inner Labyrinth
3	Ball Bearing	7	Cam	11	Outer Labyrinth
4	Oil Seal	8	Torque Arm Pin	12	Grease Seal

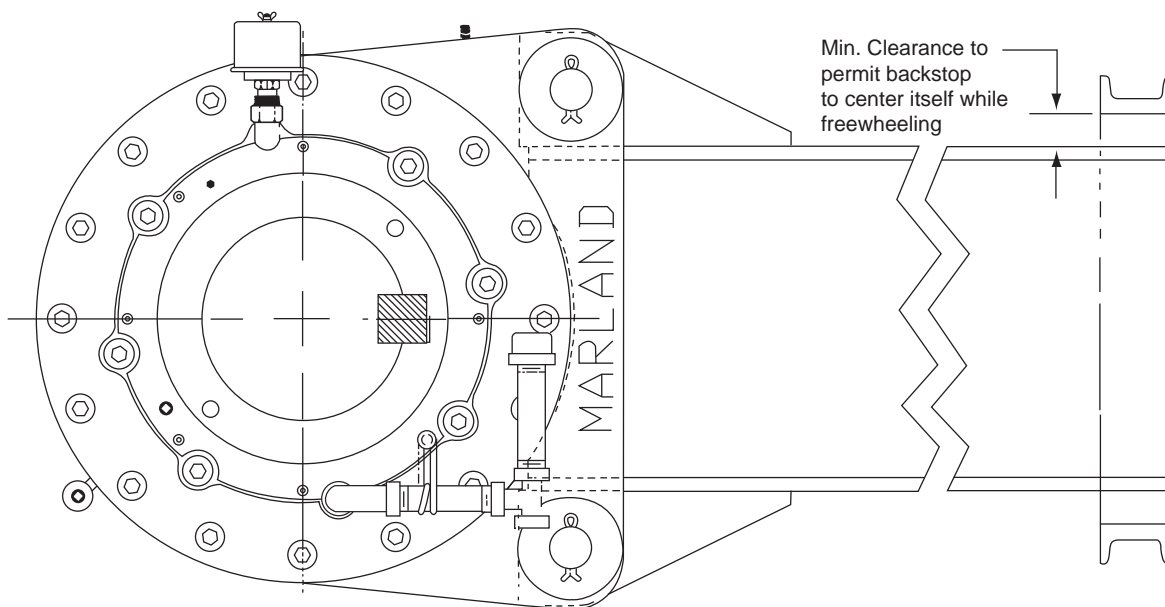

Illustration 3

BC Backstop Size	"L" Load Lbs.	Approx. Oil Capacity in Pints
3MA	1,125	3/8
6MA	2,000	1/2
12MA	2,880	3/4
18MA	3,860	1
27MA	4,920	1-1/4
45MA	7,500	1-7/8
63MA	9,690	2-1/4
90MA	13,200	3
135MA	18,420	3-1/2
180MA	23,000	4-1/2
240MA	28,800	6
375MA	37,500	9
540MA	54,000	13

Table 2

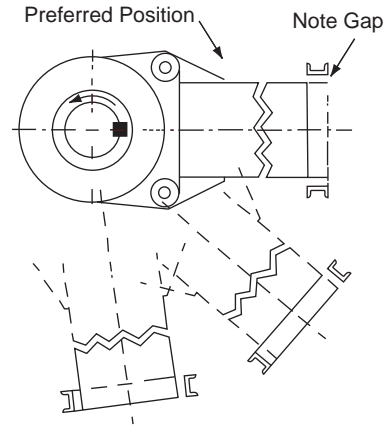

Illustration 4

Note 1: Labyrinth seals only are factory packed with grease. Before placing in operation, backstop must be filled internally with recommended oil.

CAUTION Do not fasten torque arm end rigidly to steel framework in angular or axial position. Sketch at left shows that the torque arm should be mounted so that its weight holds it in contact with the stirrup in the direction it will be backstopping.

Warranty

Marland Clutch warrants that it will repair or replace (whichever it deems advisable) any product manufactured and sold by it which proves to be defective in material or workmanship within a period of two (2) years from date of original purchase for consumer, commercial or industrial use. This warranty extends only to the original purchaser and is not transferable or assignable without Marland Clutch's prior consent.

This warranty covers normal use and does not cover damage or defect which results from alteration, accident, neglect, or improper installation, operation, or maintenance.

Marland Clutch's obligation under this warranty is limited to the repair or replacement of the defective product and in no event shall Marland Clutch be liable for consequential, indirect or incidental damages of any kind incurred by reasons of manufacture, sale or use of any defective product. Marland Clutch either assumes nor authorizes any other person to give any other warranty or to assume any other obligation or liability on its behalf.



Marland Clutch
800-216-3515 • 630-455-1752 • Fax: 630-455-1794
www.marland.com



MAGZA
DIST. AUTORIZADO

MEX (55) 53 63 23 31 MTY (81) 83 54 10 18
QRO (442) 1 95 72 60 ventas@industrialmagza.com