

SF-825 Bearing Mounted

.271/.263 dia. 5 holes (hub) equally spaced on 2.015 dia. and within .003 of true position relation to 2.313/2.311 pilot dia.

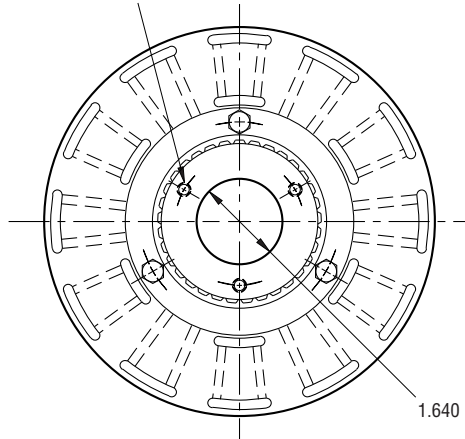

ARMATURE VIEW

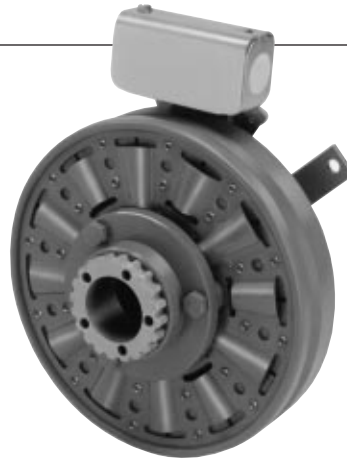
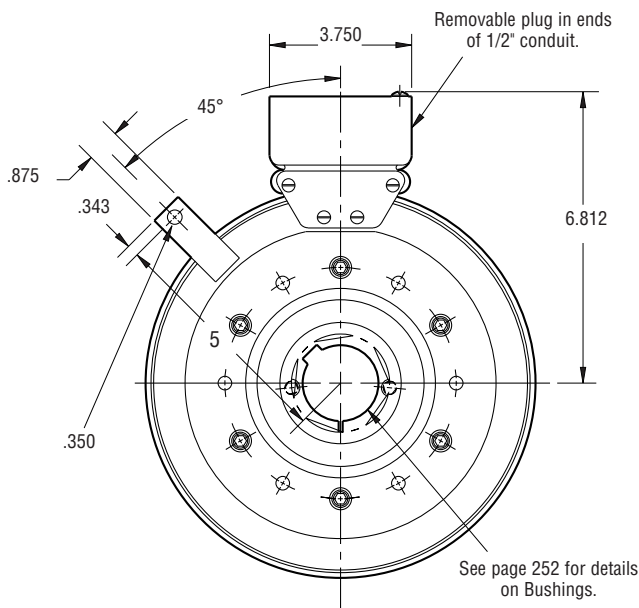

FIELD VIEW

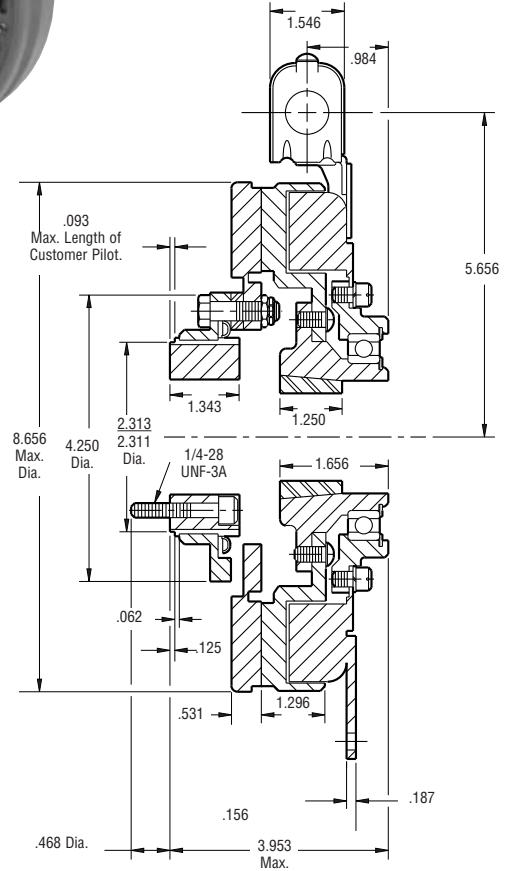

Shaft Size	.500 – 1.500
Static Torque	150 lb.ft.
Maximum Speed	3,600 rpm
Standard Voltage	D.C. 6, 24, 90

All dimensions are nominal unless otherwise noted.

Information on inertia and weights begins on page 239. Coil data is on pages 250 and 251.

Customer Shall Maintain:

1. Armature hub pilot diameter to be concentric with field and rotor mounting shaft within .010 T.I.R.



Drawing I-25573

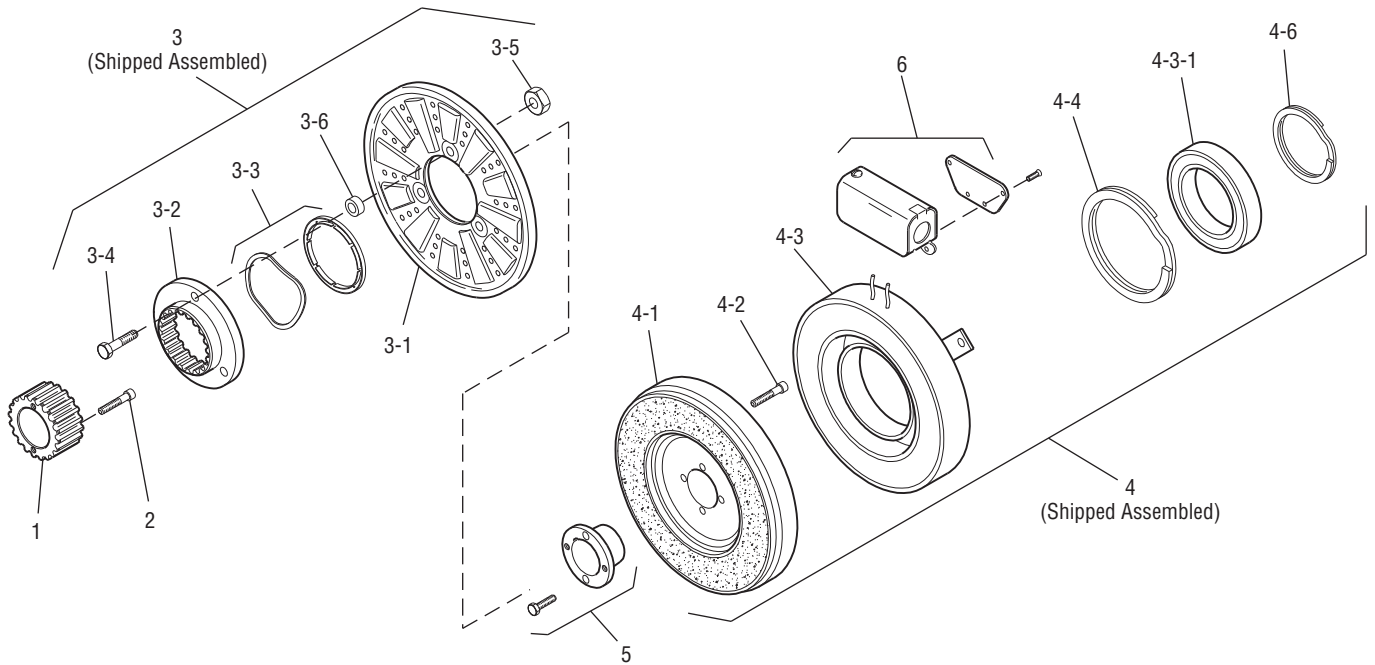

Item	Description	Part Number	Qty.
1	Splined Hub	540-0146	1
2	Accessory, Mounting	5201-101-001	1
3	Armature & Adapter Assembly	5201-111-001	1
3-1	Armature	5321-111-022	1
3-2	Splined Adapter	104-0008	1
3-3	Autogap Accessory	5321-101-006	1
3-4	Screw	797-0341	3
3-5	Locknut	661-0004	3
3-6	Spacer	748-0333	3
4	Field & Rotor Assembly		1
	6 Volt	5201-452-002	
	24 Volt	5201-452-004	
	90 Volt	5201-452-006	
4-1	Rotor	5201-751-008	1
4-2	Mounting Accessory	5201-101-005	1
4-3	Field & Bearing Assembly		1
	6 Volt	5201-451-054	
	24 Volt	5201-451-056	
	90 Volt	5201-451-057	

Item	Description	Part Number	Qty.
4-3-1	Ball Bearing	166-0142	1
4-4	Retainer Ring	748-0111	1
4-6	Retainer Ring	748-0016	1
5	Bushing*	180-0002 to 180-0018	1
6	Conduit Box	5200-101-012	1

How to Order:

1. Specify Bore Size for Item 5.
2. Specify Voltage for Item 4.
4. See Controls Section.

Example:

SF-825 Clutch per I-25573 - 90 Volt, 1" Bore

These units, when used in conjunction with the correct Warner Electric conduit box, meet the standards of UL508 and are listed under guide card #NMTR, file #59164. These units are CSA certified under file #LR11543.

*See page 252 for specific part numbers.

Refer to Service Manual P-215.