

# Clutch Coupling

## SFC-650 Bearing Mounted

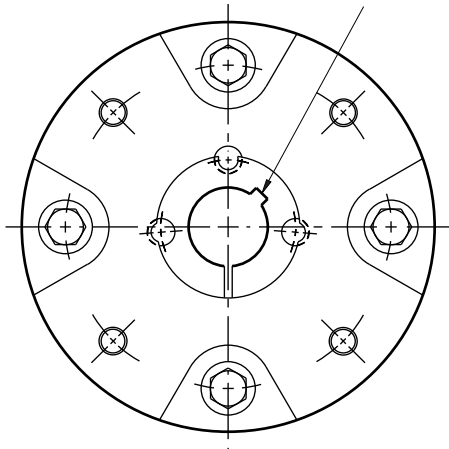

See page 252 for details on Bushings.



**HUB VIEW**

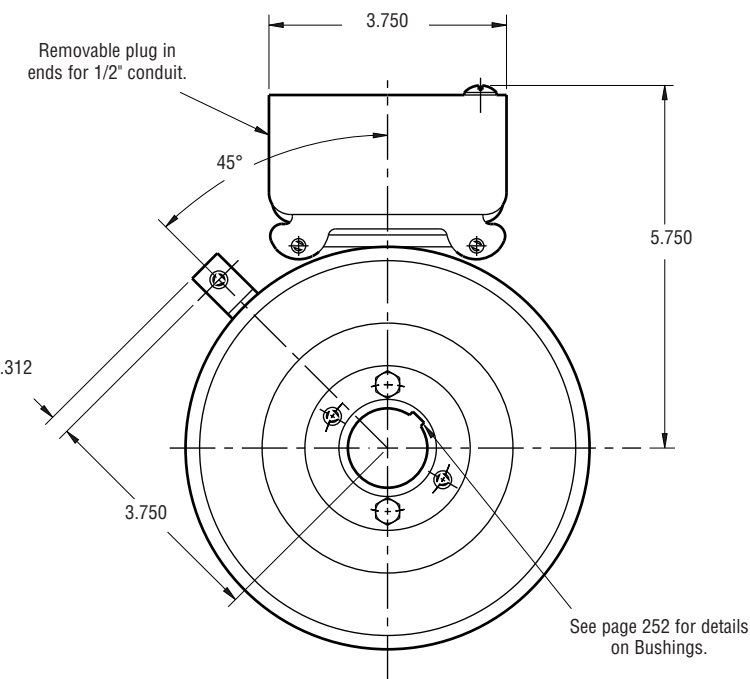

**FIELD VIEW**

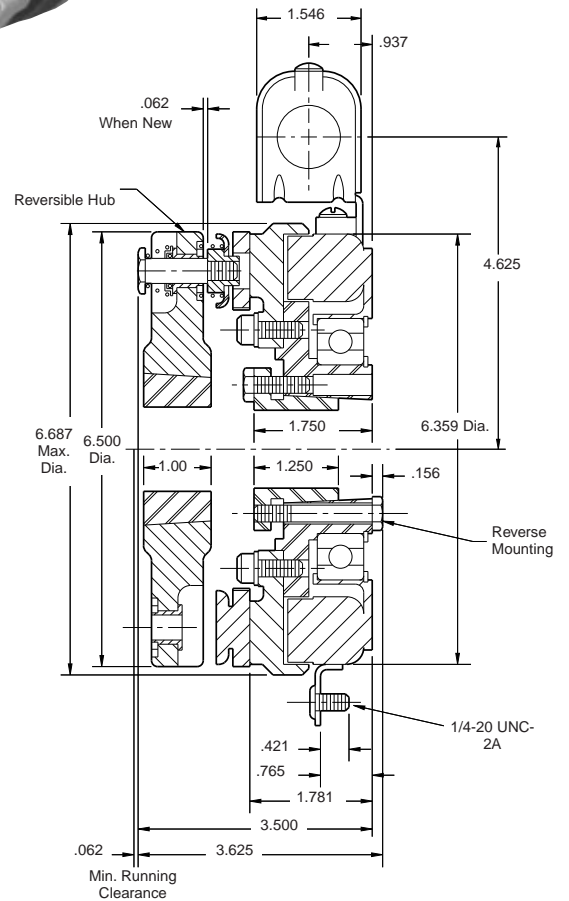

Armature Shaft	.500 – 1.625
Rotor Shaft	.500 – 1.500
Static Torque	95 lb.ft.
Maximum Speed	3,600 rpm
Standard Voltage	D.C. 6, 24, 90

**Customer Shall Maintain:**

1. Armature mounting shaft to be concentric with rotor mounting shaft within .006 T.I.R.

All dimensions are nominal unless otherwise noted.

Information on inertia and weights begins on page 239. Coil data is on pages 250 and 251.



Drawing I-25729

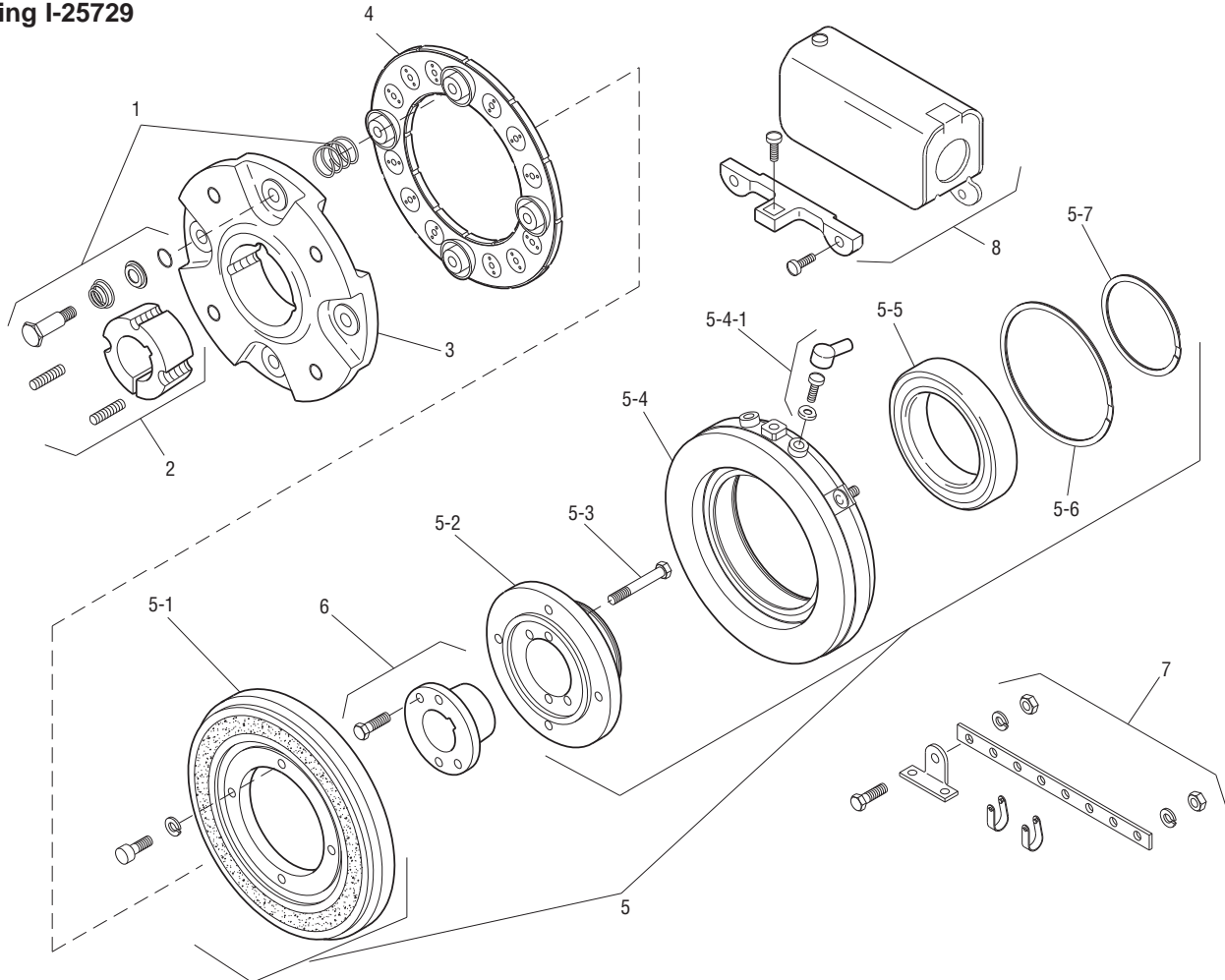

Item	Description	Part Number	Qty.
1	Autogap Accessory	5181-101-010	4
2	Bushing*		1
	1/2" to 1-5/8" Bore	180-0326 to 180-0344	
3	Armature Hub	5207-541-002	1
4	Armature	5281-111-002	1
5	Field and Rotor Assembly		1
	6 Volt	5207-452-002	
	24 Volt	5207-452-005	
	90 Volt	5207-452-004	
5-1	Rotor Assembly	5281-751-001	1
5-2	Rotor Hub	540-0614	1
5-3	Reverse Mounting Accessory	5201-101-005	1
5-4	Field Assembly		1
	6 Volt	5281-451-002	
	24 Volt	5281-451-004	
	90 Volt	5281-451-005	
5-4-1	Terminal Accessory	5311-101-001	1
5-5	Ball Bearing	166-0104	1
5-6	Retainer Ring - Exterior	748-0004	1

Item	Description	Part Number	Qty.
5-7	Retainer Ring - Interior	748-0104	1
6	Bushing*		1
	1/2" to 1-1/2" Bore	180-0002 to 180-0018	
†7	Torque Arm Accessory	5207-101-003	1
8	Conduit Box	5200-101-010	1

### How to Order:

1. Specify Bore Size of Item 2 and Item 6.
2. Specify Voltage for Item 5.
3. See Controls Section.

### Example:

SFC-650 Clutch Coupling,  
Bearing Mounted per I-25729 - 90 Volt, 1" Bore

These units, when used in conjunction with the correct Warner Electric conduit box, meet the standards of UL508 and are listed under guide card #NMTR, file #59164.

These units are CSA certified under file #LR11543

\*See page 252 for specific part numbers.

Refer to Service Manual P-202.

†Optional – not included in price.