

**POWER GRIP**

**DISC CLUTCHES AND BRAKES**

**ALIGNMENT INSTRUCTIONS**

**FOR 8" THRU 60"**



WPT Power Transmission Corp.  
P.O. Box 8148 Wichita Falls, TX 76307  
PH: (940) 761-1971 FAX: (940) 761-1989  
World Wide Web at <http://www.WPTpower.com>  
E-mail Questions/Comments: [Info@www.WPTpower.com](mailto:Info@www.WPTpower.com)

## CLUTCH ALIGNMENT INSTRUCTIONS - POWER GRIP UNITS

Check to see if both clutch/brake elements run square and true by indicating to the frame of machine.

If bearing clearance will not position shaft axially, then some method of positioning the shaft will be necessary during alignment.

Dial indicator to be located as shown in drawing below. The readings should not exceed limitations set in table below.

The readings under A and B are maximum deviations advisable for a normal running of the clutch/brake unit with no excessive wear on friction materials and no additional load on parts or machine bearings.

Consult general arrangement drawing of machine for initial cold offset setting of shafts to compensate for thermal expansion of gear case under running conditions.

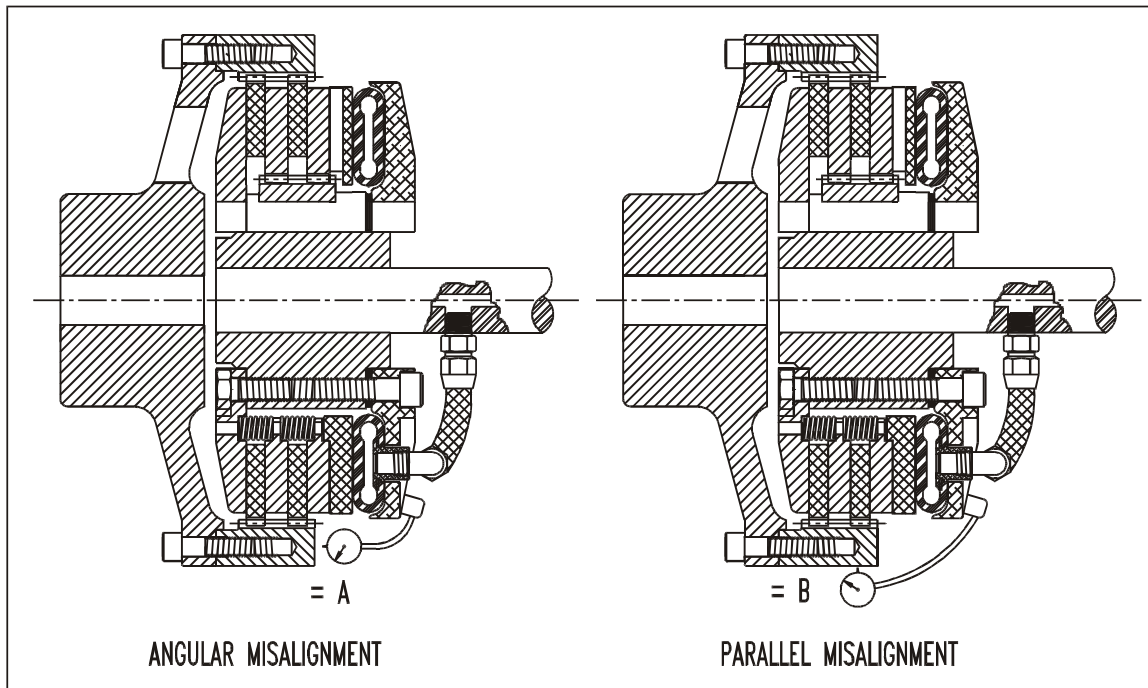

SIZE	A = T.I.R.		B = T.I.R.	
	MILLIMETERS	INCHES	MILLIMETERS	INCHES
8	0.10	0.004	0.10	0.004
11	0.15	0.006	0.15	0.006
14	0.18	0.007	0.18	0.007
16	0.20	0.008	0.20	0.008
18	0.23	0.009	0.23	0.009
21	0.28	0.011	0.28	0.011
24	0.30	0.012	0.30	0.012
24H	0.30	0.012	0.30	0.012
27	0.36	0.014	0.36	0.014
30	0.38	0.015	0.38	0.015
30H	0.38	0.015	0.38	0.015
36	0.46	0.018	0.46	0.018
42	0.53	0.021	0.53	0.021
48	0.61	0.024	0.61	0.024
60	0.76	0.030	0.76	0.030